

CE EMC TEST REPORT

Report No.: DDT-R21052503-1E1

Applicant	:	TPV Electronics (Fujian) Co., Ltd.
Address	:	Rongqiao Economic and Technological Development Zone, Fuqing City, Fujian Province, P.R.China
Equipment under Test	:	LCD Monitor
Model No.	:	**32P2***** ("*" = 0-9, A-Z, a-z, +, -, /, \ or blank. All models difference are in sale marketing)

Issued By: Tianjin Dongdian Testing Service Co., Ltd.

Address: No.19, Weisi Road, MIP, Develop Area, Tianjin, China, 300385

Tel: +86-22-58038033, E-mail: ddt@dgddt.com, <http://www.dgddt.com>



Table of Contents

1.	Summary of Test Results	8
2.	General Test Information	9
2.1.	Description of EUT	9
2.2.	Primary Function of EUT	9
2.3.	Port of EUT	10
2.4.	Accessories of EUT	10
2.5.	Test peripherals	10
2.6.	Block diagram EUT configuration for test	11
2.7.	EUT operating mode(s)	11
2.8.	Performance Criteria	12
2.9.	Deviations of test standard	12
2.10.	Test laboratory	13
2.11.	Measurement uncertainty	13
3.	Conducted Emission (mains power port)	14
3.1.	General information	14
3.2.	Test Equipment	14
3.3.	Reference standard	14
3.4.	Block diagram of test setup	14
3.5.	Limits	15
3.6.	Test procedure	15
3.7.	Test result	17
4.	Conducted Emission (Telecommunication Port)	18
4.1.	General information	18
4.2.	Test equipment	18
4.3.	Reference standard	18
4.4.	Block diagram of test setup	18
4.5.	Limits for conducted disturbance at the mains ports of class B	19
4.6.	Test procedure	19
4.7.	Test result	19
5.	Radiated Emissions (30MHz to 1GHz)	20
5.1.	General information	20
5.2.	Test equipment	20
5.3.	Reference standard	20
5.4.	Block diagram of test setup	21
5.5.	Limits	21
5.6.	Test procedure	22
5.7.	Test result	24
6.	Radiated Emissions (Above 1GHz)	25

6.1.	General information	25
6.2.	Test equipment	25
6.3.	Reference standard	25
6.4.	Block diagram of test setup	26
6.5.	Limits.....	26
6.6.	Test procedure.....	26
6.7.	Test result	26
7.	Harmonics current.....	30
7.1.	General information	30
7.2.	Test equipment	30
7.3.	Reference standard	30
7.4.	Block diagram of test setup	30
7.5.	Limits.....	31
7.6.	Test result	31
8.	Voltage fluctuation & Flicker	34
8.1.	General information	34
8.2.	Test equipment	34
8.3.	Reference standard	34
8.4.	Block diagram of test setup	35
8.5.	Limits.....	35
8.6.	Test result	35
9.	Electrostatic Discharge	38
9.1.	General information	38
9.2.	Test equipment	38
9.3.	Test and reference standards.....	38
9.4.	Block diagram of test setup	38
9.5.	Test levels and performance criterion	39
9.6.	Test procedure.....	39
9.7.	Test result	40
10.	Continuous Radio Frequency Disturbances.....	42
10.1.	General information	42
10.2.	Test equipment	42
10.3.	Test and reference standards.....	42
10.4.	Block diagram of test setup	42
10.5.	Test levels and performance criterion	43
10.6.	Test procedure.....	44
10.7.	Test result	44
11.	Electrical Fast Transients (EFT)	45
11.1.	General information	45

11.2.	Test equipment	45
11.3.	Test and reference standards.....	45
11.4.	Block diagram of test setup	45
11.5.	Test levels and performance criterion	46
11.6.	Test Procedure	46
11.7.	Test result	47
12.	Surges.....	48
12.1.	General information	48
12.2.	Test equipment	48
12.3.	Test and reference standards.....	48
12.4.	Block diagram of test setup	48
12.5.	Test levels and performance criterion	48
12.6.	Test Procedure	49
12.7.	Test result	50
13.	Continuous Conducted Disturbances.....	51
13.1.	General information	51
13.2.	Test Equipment.....	51
13.3.	Test and reference standards.....	51
13.4.	Block diagram of test setup	51
13.5.	Test levels and performance criterion	52
13.6.	Test procedure.....	53
13.7.	Test result	53
14.	Power-Frequency Magnetic Fields.....	54
14.1.	General information	54
14.2.	Test equipment	54
14.3.	Test and reference standards.....	54
14.4.	Block diagram of test setup	54
14.5.	Test levels and performance criterion	54
14.6.	Test procedure.....	55
14.7.	Test result	55
15.	Voltage Dips and Interruptions	56
15.1.	General information	56
15.2.	Test equipment	56
15.3.	Test and reference standards.....	56
15.4.	Block diagram of test setup	56
15.5.	Test levels and performance criterion	56
15.6.	Test procedure.....	57
15.7.	Test result	57
16.	Test Setup Photos	58

16.1 Conducted emission at the mains ports.....	58
16.2 Radiated emission (Below 1 GHz).....	59
16.3 Radiated emission (Above 1 GHz).....	60
16.4 Harmonic current.....	61
16.5 Voltage fluctuation & Flicker.....	61
16.6 Electrostatic discharge test.....	62
16.7 Continuous Radio Frequency Disturbances.....	62
16.8 Electrical fast transients(EFT).....	63
16.9 Surge.....	64
16.10 Continuous conducted disturbances.....	64
16.11 Power-frequency magnetic fields test.....	65
16.12 Voltage dips and interruptions.....	65

Test Report Declare

Applicant	:	TPV Electronics (Fujian) Co.,Ltd.
Address	:	Rongqiao Economic and Technological Development Zone,Fuqing City,Fujian Province,P.R.China
Equipment Under Test	:	LCD Monitor
Model No.	:	**32P2***** ("*" = 0-9, A-Z, a-z, +, -, /, \ or blank. All models difference are in sale marketing)

Test Standard Used:

EN 55032:2015, CISPR 32:2015, EN 55032:2015+AC:2016, CISPR 32:2015+cor1:2016,
 EN 55032:2015+A11:2020, BS EN 55032:2015+A11:2020,
 EN 55035:2017, BS EN 55035:2017, CISPR 35:2016, EN 55035:2017+A11:2020,
 AS/NZS CISPR 32:2015, AS/NZS CISPR 32:2015 AMD 1:2020,
 EN 61000-3-2:2014, BS EN 61000-3-2:2014, IEC 61000-3-2:2014, EN IEC 61000-3-2:2019,
 IEC 61000-3-2:2018,
 EN 61000-3-3:2013, BS EN 61000-3-3:2013, IEC 61000-3-3:2013, EN 61000-3-3:2013+A1:2019,
 IEC 61000-3-3:2013+A1:2017

Test Procedure Used:

IEC 61000-4-2:2008, BS EN 61000-4-2:2009, IEC 61000-4-3:2006+A1:2007+A2:2010,
 BS EN 61000-4-3:2006+A1:2008+A2:2010, IEC 61000-4-4:2012, BS EN 61000-4-4:2012,
 IEC 61000-4-5:2014, BS EN 61000-4-5:2014+A1:2017, IEC 61000-4-6:2013,
 BS EN 61000-4-6:2014, IEC 61000-4-8:2009, BS EN 61000-4-8:2010, IEC 61000-4-11:2004,
 IEC 61000-4-11:2004+A1:2017, BS EN 61000-4-11:2004+A1:2017

We Declare:

The equipment described above is tested and assessed by Tianjin Dongdian Testing Service Co., Ltd. and in the configuration assessed the equipment complied with the standards specified above. The tested and assessed results are contained in this test report and Tianjin Dongdian Testing Service Co., Ltd. is assumed of full responsibility for the accuracy and completeness of these assessments.

After test and evaluation, our opinion is that the equipment in accordance with above standards.

Report No.:	DDT-R21052503-1E1		
Date of Receipt:	May 26, 2021	Date of Test:	May 31, 2021 ~ Jun. 08, 2021



Prepared By:

May Zhang

May Zhang/Engineer

Approved By:

Aaron Zhang

Aaron Zhang/EMC Manager

Note: This report applies to above tested sample only. This report shall not be reproduced in parts without written approval of Tianjin Dongdian Testing Service Co., Ltd.

Revision History

Rev.	Revisions	Issue Date	Revised By
---	Initial issue	Jun. 09, 2021	

1. Summary of Test Results

Emission				
Description of Test Item	Standard		Result	
Conducted emission at AC mains terminals	EN 55032:2015+A11:2020 EN55032:2015 EN55032:2015+AC:2016 BS EN 55032:2015+A11:2020		PASS	
Conducted emission at telecommunication port	EN 55032:2015+A11:2020 EN55032:2015 EN55032:2015+AC:2016 BS EN 55032:2015+A11:2020		N/A	
Radiated emission	EN 55032:2015+A11:2020 EN55032:2015 EN55032:2015+AC:2016 BS EN 55032:2015+A11:2020		PASS	
Harmonic current	EN 61000-3-2:2014 BS EN 61000-3-2:2014 EN IEC 61000-3-2:2019		PASS	
Voltage fluctuation & Flicker	EN 61000-3-3:2013 BS EN 61000-3-3:2013 EN 61000-3-3:2013+A1:2019		PASS	
Immunity				
Description of Test Item	Standard	Result	Performance Criteria	
			Required	Observation
Electrostatic discharge (ESD)	IEC 61000-4-2:2008 BS EN 61000-4-2:2009	Pass	B	A
Radiated, radio-frequency, electromagnetic field	IEC 61000-4-3:2006+A1:2007+A2:2010 BS EN 61000-4-3:2006+A1:2008+A2:2010	Pass	A	A
Electrical fast transients (EFT)	IEC 61000-4-4:2012 BS EN 61000-4-4:2012	Pass	B	A
Surges	IEC 61000-4-5:2014 BS EN 61000-4-5:2014+A1:2017	Pass	B	A
Continuous conducted disturbances	IEC 61000-4-6:2013 BS EN 61000-4-6:2014	Pass	A	A
Power frequency magnetic field	IEC 61000-4-8:2009 BS EN 61000-4-8:2010	Pass	A	A
Voltage dips, < 5%	IEC 61000-4-11:2004 IEC 61000-4-11:2004+A1:2017 BS EN 61000-4-11:2004+A1:2017	Pass	B	A
Voltage dips, 70%		Pass	C	A
Voltage interruptions		Pass	C	B

Note: N/A is an abbreviation for Not Applicable.

2. General Test Information

2.1. Description of EUT

EUT* Name	: LCD Monitor
Model Number	: **32P2*****
Serial Number	: -
EUT function description	: Please refer to user manual of this device
Power supply	: 100-240V 50/60Hz
EUT Class	: Class B
Maximum work frequency	: 597 MHz

Note: EUT is the abbreviation of equipment under test.

2.2. Primary Function of EUT

Function	Description
<input type="checkbox"/> Broadcast reception function	N/A
<input type="checkbox"/> Print	N/A
<input type="checkbox"/> Scan	N/A
<input checked="" type="checkbox"/> Display or display output	Display
<input type="checkbox"/> Musical tone generating	N/A
<input type="checkbox"/> Networking	N/A
<input checked="" type="checkbox"/> Audio output	Audio output, Two Speaker
<input type="checkbox"/> Telephony	N/A
<input type="checkbox"/> Bluetooth	N/A
<input type="checkbox"/> Other:	N/A

Note: “” means the product does not have this function, “” means the product has this function, N/A means not applicable

2.3. Port of EUT

Port	Description
<input checked="" type="checkbox"/> AC mains power port	AC Main Port
<input checked="" type="checkbox"/> DC network power port	N/A
<input checked="" type="checkbox"/> Wired network port	N/A
<input checked="" type="checkbox"/> Signal data/control port	Two HDMI port, One DP port, One Type-C, Five USB Port
<input checked="" type="checkbox"/> Antenna port	N/A
<input checked="" type="checkbox"/> Broadcast receiver tuner port	N/A
<input checked="" type="checkbox"/> Audio output port	One audio out port, Two Speaker
<input checked="" type="checkbox"/> Video output port	N/A
<input checked="" type="checkbox"/> Other:	N/A

Note: "☒" means the product does not have this port, "☑" means the product has this port, N/A means not applicable

2.4. Accessories of EUT

Description of Accessories	Manufacturer	Model number	Description	Remark
AC Cable	N/A	N/A	Length: 1.5m/1.8m, Unshielded	N/A
HDMI Cable	N/A	N/A	Length: 1.5m/1.8m, Shielded	N/A
DP Cable	N/A	N/A	Length: 1.5m/1.8m, Shielded	N/A
Type-C Cable	N/A	N/A	Length: 1.5m/1.8m, Shielded	N/A
USB Cable	N/A	N/A	Length: 1.5m/1.8m, Shielded	N/A
AUDIO Cable	N/A	N/A	Length: 1.5m/1.8m, Shielded	N/A

2.5. Test peripherals

Device	Manufacturer	Model No.	Serial No.	Remark
Desktop PC	HP	TPC-W058-MT	8CG0321Q58	N/A
Desktop PC	Samsung	DM700T6A-A99	JVTG98EJ2C004QX	N/A
Desktop PC	Samsung	DM700T6A-A99	JVTG98EJ2C0087L	N/A
Laptop	HP	HP ProBook 455R G6	5CD0122F5D	N/A
Keyboard	DELL	N/A	N/A	N/A
Mouse	DELL	N/A	N/A	N/A
DVD	PHILIPS	TAEP200/93	HCPE2025000750	N/A
Headphone	N/A	N/A	N/A	N/A
Speaker	JBL	GO2+	N/A	N/A

2.6. Block diagram EUT configuration for test

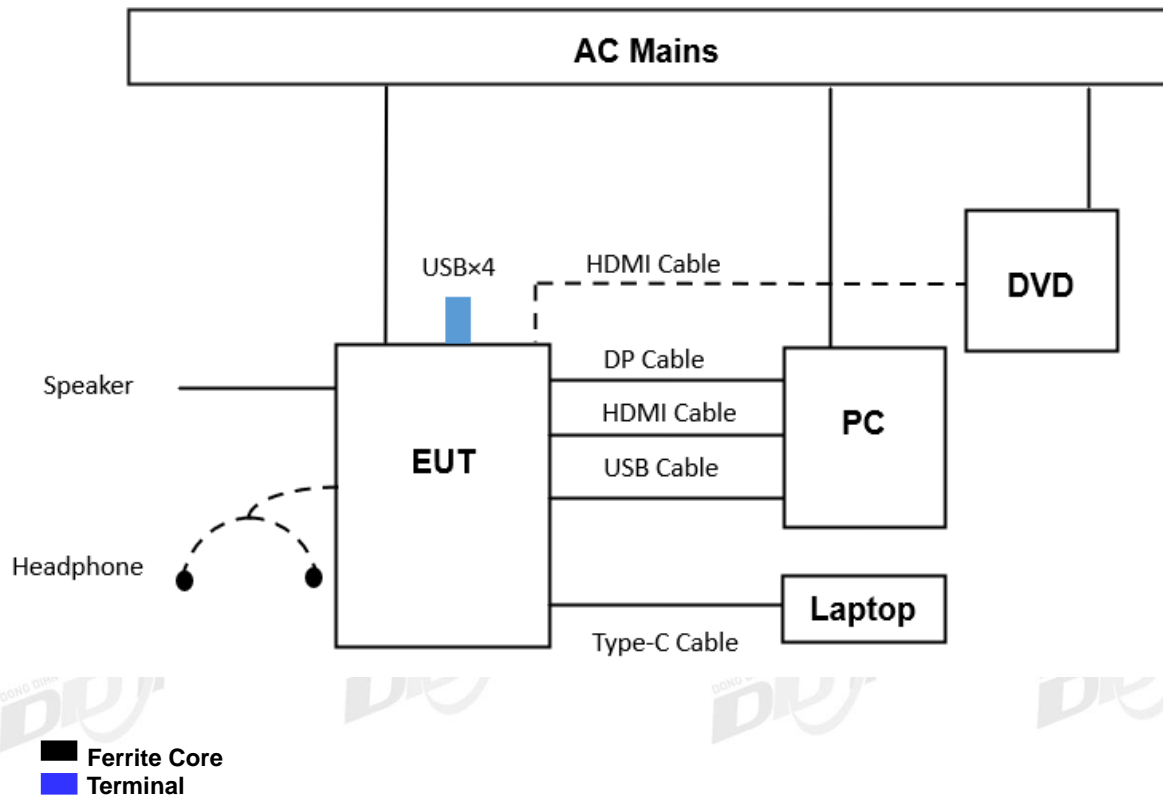

2.7. EUT operating mode(s)

Mode1: HDMI1	Connect HDMI cable from PC's HDMI port to EUT's HDMI Port. The test signal is color bars with moving picture element according to ITU-R BT 471-1.
Mode2: HDMI2	Connect HDMI cable from PC's HDMI port to EUT's HDMI Port. The test signal is color bars with moving picture element according to ITU-R BT 471-1.
Mode3: DP	Connect DP cable from PC's DP port to EUT's DP Port. The test signal is color bars with moving picture element according to ITU-R BT 471-1.
Mode4: Type-C	Connect Type-C cable from PC's Type-C port to EUT's Type-C Port. The test signal is color bars with moving picture element according to ITU-R BT 471-1.

2.8. Performance Criteria

During and/or after immunity testing for EN55035:2017, the EUT was monitored to the following performance criterion.

Criterion	Operating mode(s)	Description
A	1,2,3,4	<p>No noticeable degradation or loss of function is allowed during the test. The EUT shall continue to operate as intended without operator intervention.</p> <p>The product conforms with the requirements of clause 8 of EN55035:2017.</p> <p>The product conforms with the requirements of Annex of EN55035:2017.</p> <p><input type="checkbox"/> Annex A <input type="checkbox"/> Annex B <input type="checkbox"/> Annex C <input checked="" type="checkbox"/> Annex D <input type="checkbox"/> Annex E <input type="checkbox"/> Annex F <input checked="" type="checkbox"/> Annex G</p>
B	1,2,3,4	<p>No noticeable degradation or loss of function is allowed after the test. The EUT shall continue to operate as intended without operator intervention. During the test, degradation of performance is allowed.. No change of operating state or stored data is allowed to persist after the test.</p> <p>The product conforms with the requirements of clause 8 of EN55035:2017.</p> <p>The product conforms with the requirements of Annex of EN55035:2017.</p> <p><input type="checkbox"/> Annex A <input type="checkbox"/> Annex B <input type="checkbox"/> Annex C <input checked="" type="checkbox"/> Annex D <input type="checkbox"/> Annex E <input type="checkbox"/> Annex F <input checked="" type="checkbox"/> Annex G</p>
C	1,2,3,4	<p>Loss of function is allowed, provided that the function is self recoverable or can be restored by the operation of the controls by the user.</p> <p>The product conforms with the requirements of clause 8 of EN55035:2017.</p> <p>The product conforms with the requirements of Annex of EN55035:2017.</p> <p><input type="checkbox"/> Annex A <input type="checkbox"/> Annex B <input type="checkbox"/> Annex C <input checked="" type="checkbox"/> Annex D <input type="checkbox"/> Annex E <input type="checkbox"/> Annex F <input checked="" type="checkbox"/> Annex G</p>

2.9. Deviations of test standard

[Standard deviation 1] Surge immunity test was done according to IEC 61000-4-5:2014 instead of IEC 61000-4-5:2005.

[Standard deviation 2] Radio-frequency conducted immunity test was done according to IEC 61000-4-6:2013 instead of IEC 61000-4-6:2008.

2.10. Test laboratory

Tianjin Dongdian Testing Service Co., Ltd.

Address: No.19, Weisi Road, MIP, Develop Area, Tianjin, China, 300385

Tel: +86-22-58038033, <http://www.dgddt.com>, Email: ddt@dgddt.com

NVLAP (National Voluntary Laboratory Accreditation Program) CODE: 500036-0

CNAS (China National Accreditation Service for Conformity Assessment) CODE: L13402

FCC Designation Number: CN5004; FCC Test Firm Registration Number: 368676

2.11. Measurement uncertainty

Test Item		Uncertainty
Conducted emission	Main terminal	3.4dB (150KHz-30MHz)
	Telecommunication (ISN T800)	4.59dB
	Telecommunication (ISN ST08)	3.5dB
Uncertainty for 10m Radiation Emission test (30MHz-1GHz)		5.2 dB (Antenna Polarize: H)
		5.2 dB (Antenna Polarize: V)
Uncertainty for Radiation disturbance test (1GHz to 6GHz)		5.0dB
Harmonics current		3.1 %
Voltage fluctuation & Flicker		1.7 %

Note: This uncertainty represents an expanded uncertainty expressed at approximately the 95% confidence level using a coverage factor of k=2.
We have conducted the Electrostatic discharge, Electrical fast transient/burst, Surge, Voltage dips, short interruptions and voltage variations tests to check the uncertainty. Radiated, radio-frequency, electromagnetic field 5.4dB. Conducted disturbances, induced by radio-frequency fields 1.1dB.

3. Conducted Emission (mains power port)

3.1. General information

Test date	Jun. 07, 2021	Test engineer	Sam	
Climate condition	Ambient temperature	25.6±1°C	Relative humidity	39±1%
	Atmospheric pressure	100.5±0.2 kPa		
Test place	Shield Room 2#			

3.2. Test Equipment

Equipment	Manufacturer	Model No.	Serial No.	Last Cal.	Cal. Interval
Test Receiver	R&S	ESCI	101032	Mar. 03, 2021	1 Year
LISN 1	R&S	ENV216	101122	Nov. 09, 2020	1 Year
LISN 2	R&S	ENV216	101254	Mar. 17, 2021	1 Year
Test software	TOYO	EP5/CE	V 5.4.40	N/A	N/A

3.3. Reference standard

EN 55032:2015+A11:2020 (Class B)

EN 55032:2015

EN 55032:2015+AC:2016

BS EN 55032:2015+A11:2020

3.4. Block diagram of test setup

For table-top equipment

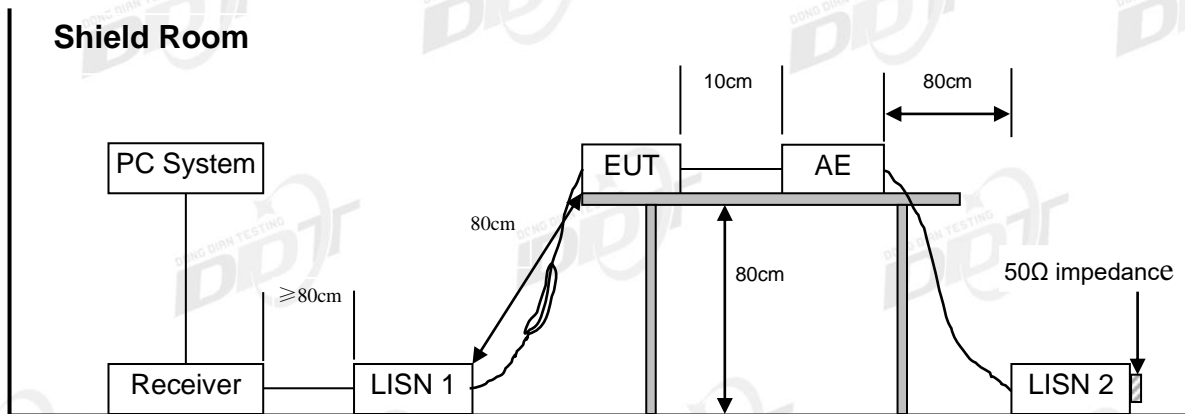

For floor standing equipment

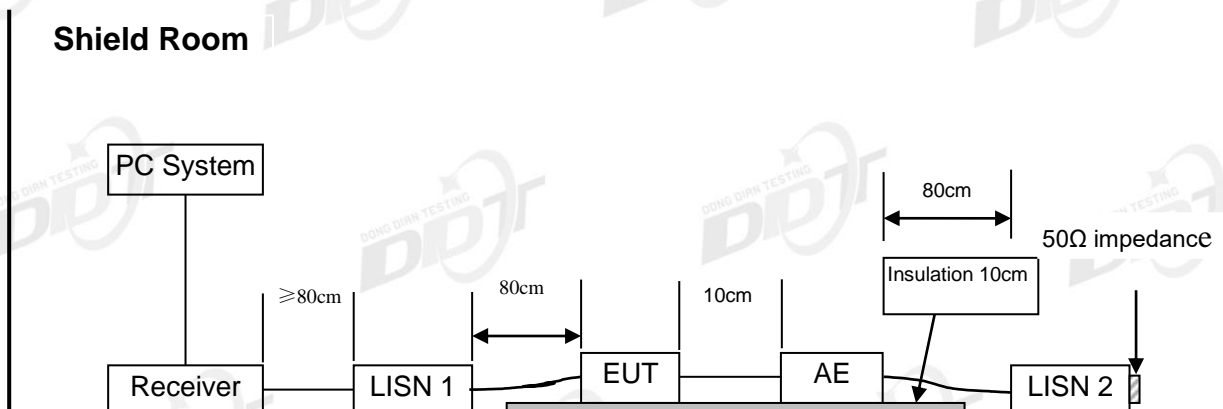

For combinations equipment

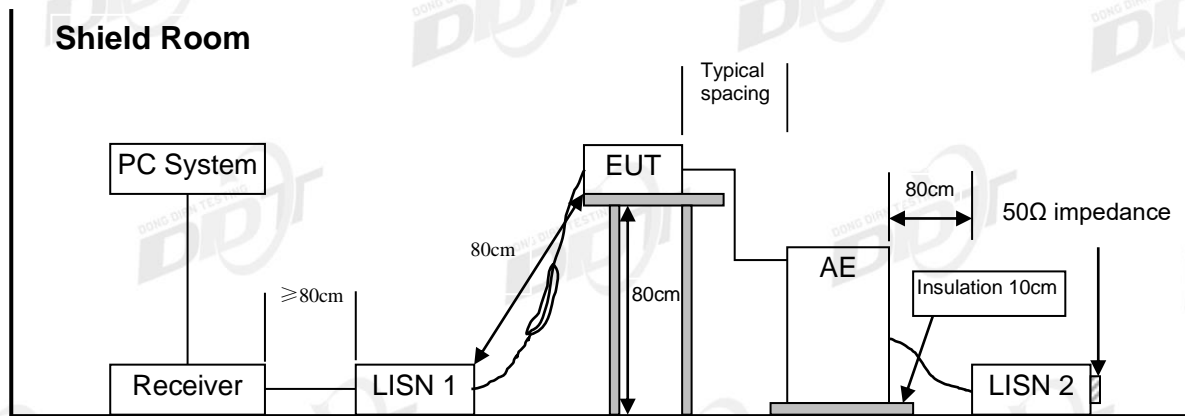

3.5. Limits

Class A

Frequency	Quasi-Peak Level dB(μ V)	Average Level dB(μ V)
150kHz ~ 500kHz	79	66
500kHz ~ 30MHz	73	60

Class B

Frequency	Quasi-Peak Level dB(μ V)	Average Level dB(μ V)
150kHz ~ 500kHz	66 ~ 56*	56 ~ 46*
500kHz ~ 5MHz	56	46
5MHz ~ 30MHz	60	50

Notes: 1. * Decreasing linearly with logarithm of frequency.

2. The lower limit shall apply at the transition frequencies.

3.6. Test procedure

- (1) The EUT was placed on a non-metallic table, 80cm above the ground plane.
- (2) The EUT's power adapter was connected to the power mains through a line impedance stabilization network (L.I.S.N). which this provided a 50-ohm coupling impedance for the EUT (Please refer to the block diagram of the test setup and photographs). Both sides of power line were checked for maximum conducted disturbance. In order to find the maximum emission, the relative positions of equipment and all of the interface cables were changed according to EN 55032 on conducted disturbance emission test.
- (3) The bandwidth of test receiver is set at 9 kHz.
- (4) The frequency range from 150 kHz to 30MHz is checked.
- (5) Pre-scan measurements were performed in all operating mode or resolution.

But final measurements were performed in worst cases based on pre-scan

measurements.

The EUT with following test modes were pre-tested:

No.	Test Voltage	Operation Mode	Cable Length	Resolution
1.	230V 50Hz	Mode 1 HDMI1	1.8m	3840*2160@60Hz
2.			1.8m	1920*1080@60Hz
3.			1.8m	800*600@60Hz
4.		Mode 2 HDMI2	1.5m	3840*2160@60Hz
5.			1.5m	1920*1080@60Hz
6.			1.5m	800*600@60Hz
7.		HDMI1/2	1.8m	DVD
8.		Mode 3 DP	1.8m	3840*2160@60Hz
9.			1.8m	1920*1080@60Hz
10.			1.8m	800*600@60Hz
11.			1.5m	3840*2160@60Hz
12.		Mode 4 Type-C	1.8m	3840*2160@60Hz
13.			1.8m	1920*1080@60Hz
14.			1.8m	800*600@60Hz
15.			1.8m	Full Load
16.				1.5m
17.	230V 50Hz	HDMI1 3840*2160@60Hz with 1.5m power cord		
18.	110V 60Hz	HDMI1 3840*2160@60Hz		

* Means the worst test mode.

3.7. Test result

Operating Mode 1: HDMI1 IN

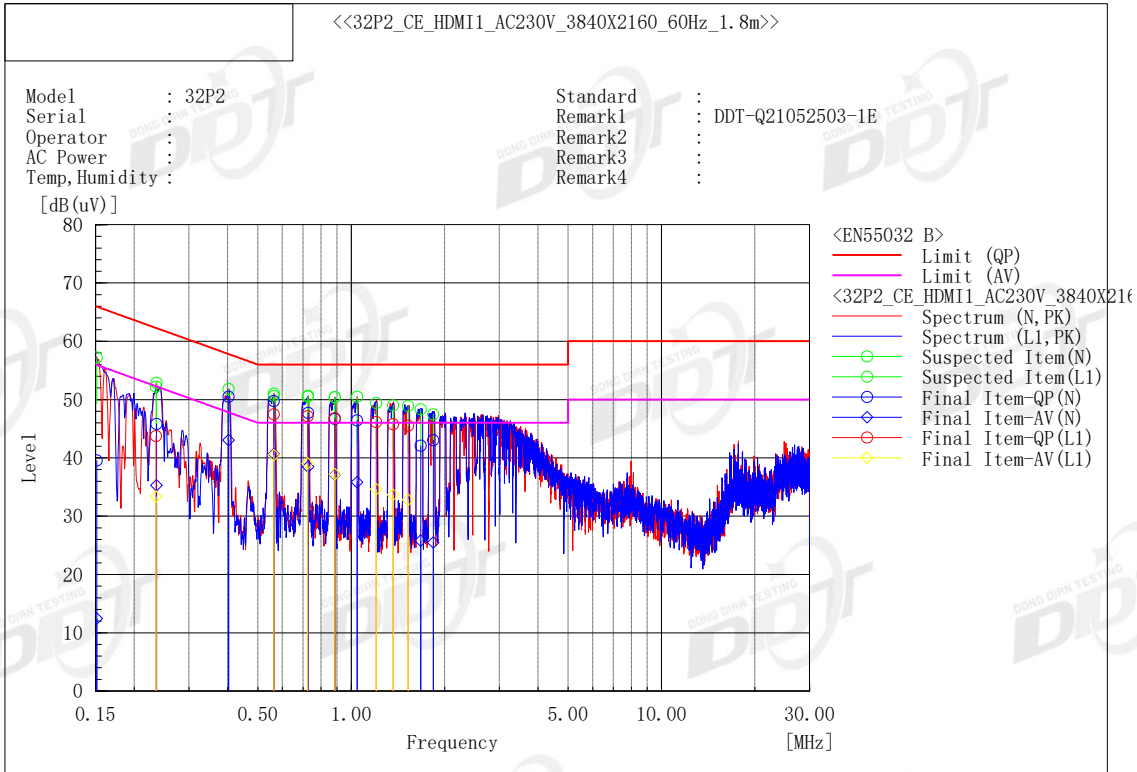

Final Result

--- N Phase ---

No.	Frequency [MHz]	Reading QP [dB(uV)]	Reading CAV [dB(uV)]	c. f [dB]	Result QP [dB(uV)]	Result CAV [dB(uV)]	Limit QP [dB(uV)]	Limit AV [dB(uV)]	Margin QP [dB]	Margin CAV [dB]
1	0.40246	40.8	33.3	9.7	50.5	43.0	57.8	47.8	7.3	4.8
2	0.56352	40.0	30.9	9.7	49.7	40.6	56.0	46.0	6.3	5.4
3	0.72756	37.9	28.7	9.8	47.7	38.5	56.0	46.0	8.3	7.5
4	1.04514	36.6	26.0	9.8	46.4	35.8	56.0	46.0	9.6	10.2
5	0.88635	36.9	27.3	9.8	46.7	37.1	56.0	46.0	9.3	8.9
6	1.67587	32.3	16.0	9.8	42.1	25.8	56.0	46.0	13.9	20.2
7	1.84057	33.2	15.7	9.8	43.0	25.5	56.0	46.0	13.0	20.5
8	0.15148	29.8	2.7	9.7	39.5	12.4	65.9	55.9	26.4	43.5
9	0.23573	36.1	25.6	9.7	45.8	35.3	62.2	52.2	16.4	16.9

--- L1 Phase ---

No.	Frequency [MHz]	Reading QP [dB(uV)]	Reading CAV [dB(uV)]	c. f [dB]	Result QP [dB(uV)]	Result CAV [dB(uV)]	Limit QP [dB(uV)]	Limit AV [dB(uV)]	Margin QP [dB]	Margin CAV [dB]
1	0.56359	37.8	30.8	9.7	47.5	40.5	56.0	46.0	8.5	5.5
2	0.72386	37.4	29.3	9.7	47.1	39.0	56.0	46.0	8.9	7.0
3	0.88487	37.1	27.5	9.7	46.8	37.2	56.0	46.0	9.2	8.8
4	1.20393	36.4	24.9	9.7	46.1	34.6	56.0	46.0	9.9	11.4
5	1.36567	36.1	23.9	9.7	45.8	33.6	56.0	46.0	10.2	12.4
6	1.52668	35.8	23.1	9.7	45.5	32.8	56.0	46.0	10.5	13.2
7	0.23513	34.0	23.6	9.7	43.7	33.3	62.3	52.3	18.6	19.0

Note1) Level (Quasi-Peak and/or C/Average) = Meter Reading + Factor

Note2) Line = Polarity of input power (Live or Neutral)

N : Abbreviation of Neutral Polarity, L1 : Abbreviation of Live Polarity,

Note3) Factor = LISN Insertion Loss + Cable Loss

Note4) Margin = Limit – Level (Quasi-Peak and/or C/Average)

Note5) C/Average : Abbreviation of CISPR Average

4. Conducted Emission (Telecommunication Port)

4.1. General information

Test date	N/A	Test engineer	N/A	
Climate condition	Ambient temperature	N/A	Relative humidity	N/A
	Atmospheric pressure	N/A		
Test place	Shield Room 2#			

4.2. Test equipment

Equipment	Manufacturer	Model No.	Serial No.	Last Cal.	Cal. Interval
Test Receiver	R&S	ESCI	101032	Mar. 03, 2021	1 Year
ISN	TESEQ	T800	30844	Feb. 27, 2021	1 Year
ISN	TESEQ	ST08	33992	Feb. 27, 2021	1 Year
Test software	TOYO	EP5/CE	V 5.4.40	N/A	N/A

4.3. Reference standard

EN 55032:2015+A11:2020 (Class B)

EN 55032:2015

EN 55032:2015+AC:2016

BS EN 55032:2015+A11:2020

4.4. Block diagram of test setup

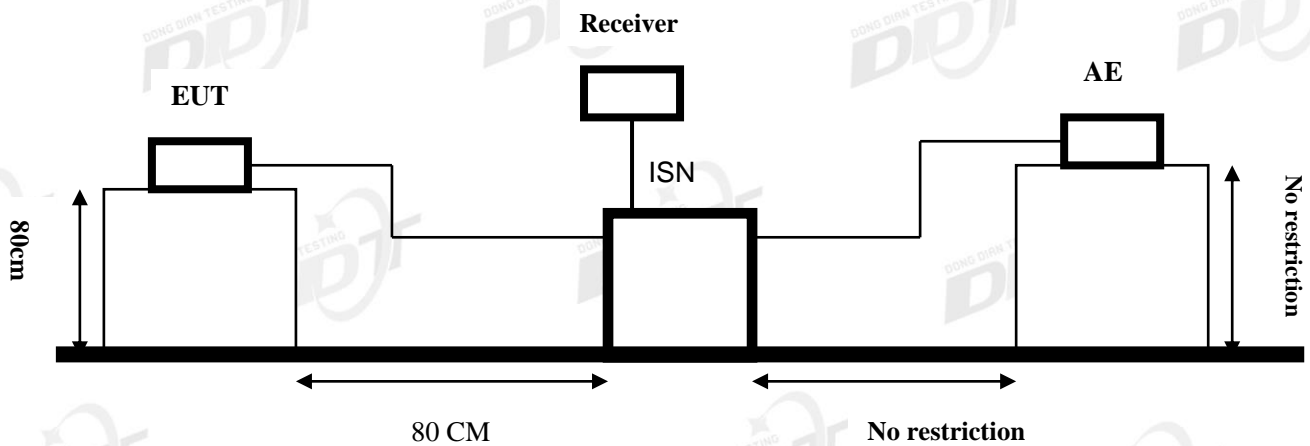

EUT means Equipment Under Test
 AE means Associated Equipment.

4.5. Limits for conducted disturbance at the telecommunication ports of class B

Frequency	Quasi-Peak Level dB(μ V)	Average Level dB(μ V)
150kHz ~ 500kHz	84 ~ 74*	74 ~ 64*
5MHz ~ 30MHz	74	64

Notes: 1. * Decreasing linearly with logarithm of frequency.

2. The lower limit shall apply at the transition frequencies.

4.6. Test procedure

The EUT was placed on a 0.8m high non-metallic table in shielded room.
Connect ISN directly to reference ground plane.

The measured voltage at the measurement port of the ISN should correct the reading by adding the voltage division factor of the ISN, and compare to the voltage limit.

For Local Area Network (LAN) device, in order to make reliable emission measurements representative of high LAN utilization it is only necessary to create a condition of LAN utilization in excess of 10 % and sustain that level for a minimum of 250 ms. The content of the test traffic should consist of both periodic and pseudo-random messages in order to emulate realistic types of data transmission (e.g. random: files compressed or encrypted; periodic: uncompressed graphic files, memory dumps, screen updates, disk images). If the LAN maintains transmission during idle periods measurements shall also be made during idle periods.

When disturbance voltage measurements are performed on a single unscreened balanced pair, an adequate ISN for two wires shall be used; when performed on unscreened cables containing two balanced pairs, an adequate ISN for four wires shall be used.

4.7. Test result

Not applicable: This product does not have a communication port.

5. Radiated Emissions (30MHz to 1GHz)

5.1. General information

Test date	May 31, 2021	Test engineer	Sam	
Climate condition	Ambient temperature	22.7±1°C	Relative humidity	39±1%
	Atmospheric pressure	100.2±0.2kPa		
Test place	10m Chamber			

5.2. Test equipment

Equipment	Manufacturer	Model No.	Serial No.	Last Cal.	Cal. Interval
EMI Test Receiver	R&S	ESCI	101024	Mar. 03, 2021	1 Year
EMI Test Receiver	R&S	ESCI	101397	Mar. 03, 2021	1 Year
Bilog Antenna	TESEQ	CBL6112D	30997	Jan, 17, 2020	2 Year
Bilog Antenna	TESEQ	CBL6112D	30999	Jan, 17, 2020	2 Year
Amplifier	Sonoma	310N	300913	Mar. 03, 2021	1 Year
Amplifier	Sonoma	310N	300914	Mar. 03, 2021	1 Year
Ant Mast	Innco	MA4000	N/A	N/A	N/A
Ant Mast	Innco	MA4000	N/A	N/A	N/A
Mast Controller	Innco	CO2000	N/A	N/A	N/A
Mast Controller	Innco	CO2000	N/A	N/A	N/A
RF Selector 4CH	TOYO	NS4904N	Selector1	N/A	N/A
RF Selector 4CH	TOYO	NS4904N	Selector2	N/A	N/A
Test software	TOYO	EP5/RE	V 5.7.10	N/A	N/A

Notes. N/A means Not applicable.

5.3. Reference standard

EN 55032:2015+A11:2020 (Class B)
 EN 55032:2015
 EN 55032:2015+AC:2016
 BS EN 55032:2015+A11:2020

5.4. Block diagram of test setup

Below 1GHz
For table-top equipment

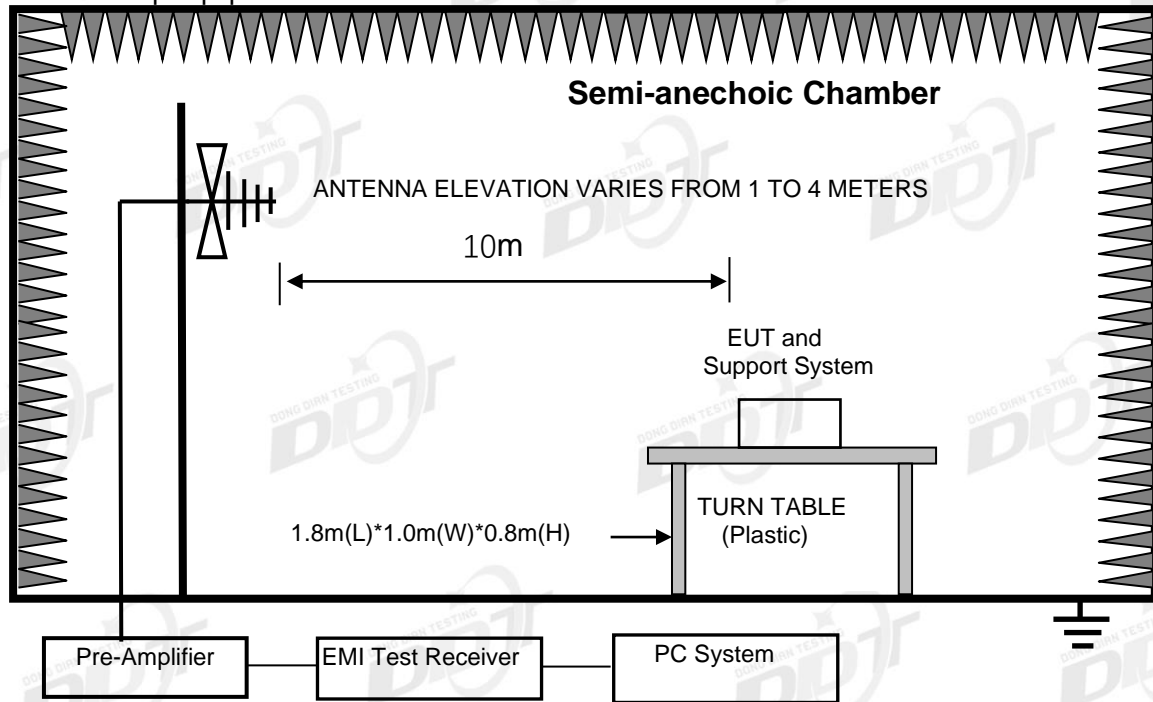

5.5. Limits

Class A

Equipment	Frequency	Field Strengths Limits at 10m measuring distance dB(μ V)/m	Field Strengths Limits at 3m measuring distance dB(μ V)/m
Class A Equipment	30MHz to 230MHz	40	50
	230MHz to 1000MHz	47	57

Class B

Equipment	Frequency	Field Strengths Limits at 10m measuring distance dB(μ V)/m	Field Strengths Limits at 3m measuring distance dB(μ V)/m
Class B Equipment	30MHz to 230MHz	30	40
	230MHz to 1000MHz	37	47
FM receivers*	30MHz to 1000MHz	Fundamental 50	Fundamental 60
	30MHz to 300MHz	Harmonics 42	Harmonics 52
	300MHz to 1000MHz	Harmonics 46	Harmonics 56

*: these relaxed limits apply only to emission at the fundamental and harmonic frequencies of the local oscillator signals at all other frequencies shall be compliant with the limits of class B equipment given above.

Note: (1) The smaller limit shall apply at the cross point between two frequency bands.

(2) Distance is the distance in meters between the measuring instrument, antenna and the closest point of any part of the device or system.

5.6. Test procedure

For Radiated emissions:

- (1) The EUT was placed on a non-metallic table, 80 cm above the ground plane inside an semi-anechoic chamber.
- (2) Test antenna was located \square 3m / \boxtimes 10m (see note) from the EUT on an adjustable mast. A pre-scan was first performed in order to find prominent radiated emissions. For final emissions measurements at each frequency of interest, the EUT were rotated and the antenna height was varied between 1m and 4m in order to maximize the emission. Measurements in both horizontal and vertical polarities were made and the data was recorded. In order to find the maximum emission, the relative positions of equipment and all of the interface cables were changed according to EN 55032 on radiated emission test.
- (3) Spectrum frequency from 30MHz to \boxtimes 1GHz / \square 2GHz was investigated.
- (4) For final emissions measurements at each frequency of interest, the EUT were rotated and the antenna height was varied between 1m and 4m in order to maximize the emission. Measurements in both horizontal and vertical polarities were made and the data was recorded. In order to find the maximum emission, the relative positions of equipment and all of the interface cables were changed according to EN 55032 on Radiated Emission test.
- (5) For emissions from 30MHz to 1GHz, Quasi-Peak values were measured with EMI Receiver and the bandwidth of Receiver is 120 kHz.
- (6) Final measurements consisted of 3 steps.
First step, frequency fine tuning to find exact emission frequency.
Second step, rechecking to search for maximum height and azimuth for interference from EUT
In final step, there are conducted measuring with quasi-peak detector for points which are detected from 1st step & 2nd step.
Results checked manually and points close to the limit line were re-measured.
- (7) Pre-scan measurements were performed in all operating mode or resolution. But final measurements were performed in worst cases based on pre-scan measurements.

The EUT with following test modes were pre-tested:

No.	Test Voltage	Operation Mode	Cable Length	Resolution
1.	230V 50Hz	Mode 1 HDMI1	1.8m	3840*2160@60Hz
2.			1.8m	1920*1080@60Hz
3.			1.8m	800*600@60Hz
4. *		Mode 2 HDMI2	1.5m	3840*2160@60Hz
5.			1.5m	1920*1080@60Hz
6.			1.5m	800*600@60Hz
7.		HDMI1/2	1.8m	DVD
8.		Mode 3 DP	1.8m	3840*2160@60Hz
9.			1.8m	1920*1080@60Hz
10.			1.8m	800*600@60Hz
11.			1.5m	800*600@60Hz
12.			1.8m	3840*2160@60Hz
13.		Mode 4 Type-C	1.8m	1920*1080@60Hz
14.			1.8m	800*600@60Hz
15.			1.8m	Full Load
16.			1.5m	800*600@60Hz
17.	230V 50Hz	HDMI2 3840*2160@60Hz with 1.5m power cord		
18.	110V 60Hz	HDMI2 3840*2160@60Hz		
19.	HDMI2 1920*1080@60Hz with headphone			
20.	HDMI2 1920*1080@60Hz without headphone			

* Means the worst test mode.

5.7. Test result

PASS. (See below detailed test result)

Note: All emissions not reported below are too low against the prescribed limits.

Operating Mode 2: HDMI2 IN

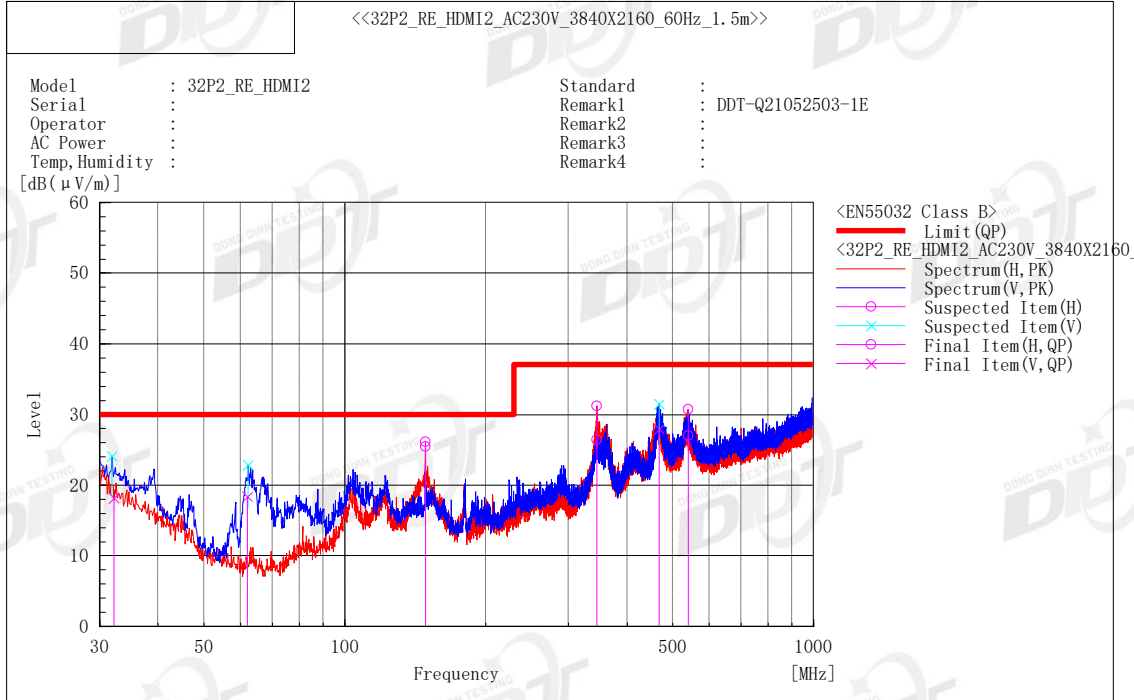

Final Result

No.	Frequency [MHz]	(P)	Reading QP [dB(µV)]	c. f [dB(1/m)]	Result QP [dB(µV/m)]	Limit QP [dB(µV/m)]	Margin [dB]	Height [cm]	Angle [°]	System
1	148.508	H	38.3	-12.8	25.5	30.0	4.5	376.0	0.1	1
2	468.964	V	30.9	-3.0	27.9	37.0	9.1	134.0	158.5	2
3	345.414	H	34.2	-7.8	26.4	37.0	10.6	234.0	105.6	1
4	32.122	V	24.9	-6.7	18.2	30.0	11.8	175.0	107.6	2
5	539.593	H	29.4	-2.4	27.0	37.0	10.0	206.0	33.9	1
6	61.967	V	35.9	-17.5	18.4	30.0	11.6	134.0	85.2	2

Note) Receiving antenna polarization : Horizontal and/or Vertical

Test Distance : 10 m, Antenna Height : 1 m to 4 m

Level QP (Quasi-Peak) = Reading QP + Factor (Antenna Factor + Cable Loss - Amp. Gain)

Margin QP (Quasi-Peak) = Limit - Level QP

6. Radiated Emissions (Above 1GHz)

6.1. General information

Test date	Jun. 03, 2021	Test engineer	Sam	
Climate condition	Ambient temperature	23.2±1°C	Relative humidity	39±1%
	Atmospheric pressure	100.7±0.2kPa		
Test place	10m Chamber			

6.2. Test equipment

Equipment	Manufacturer	Model No.	Serial No.	Last Cal.	Cal. Interval
EMI Test Receiver	R&S	ESU26	100244	Mar. 04, 2021	1 Year
Double Ridged Horn Antenna	TESEQ	BHA9118	31754	Sep. 14, 2019	2 Year
Pre-amplifier	TOYO	TPA0108-40	0934	Mar. 02,2021	1 Year
Test software	TOYO	EP5/RE	V 5.7.10	N/A	N/A

Notes. N/A means Not applicable.

6.3. Reference standard

EN 55032:2015+A11:2020 (Class B)
 EN 55032:2015
 EN 55032:2015+AC:2016
 BS EN 55032:2015+A11:2020

6.4. Block diagram of test setup

Above 1GHz

For table-top equipment

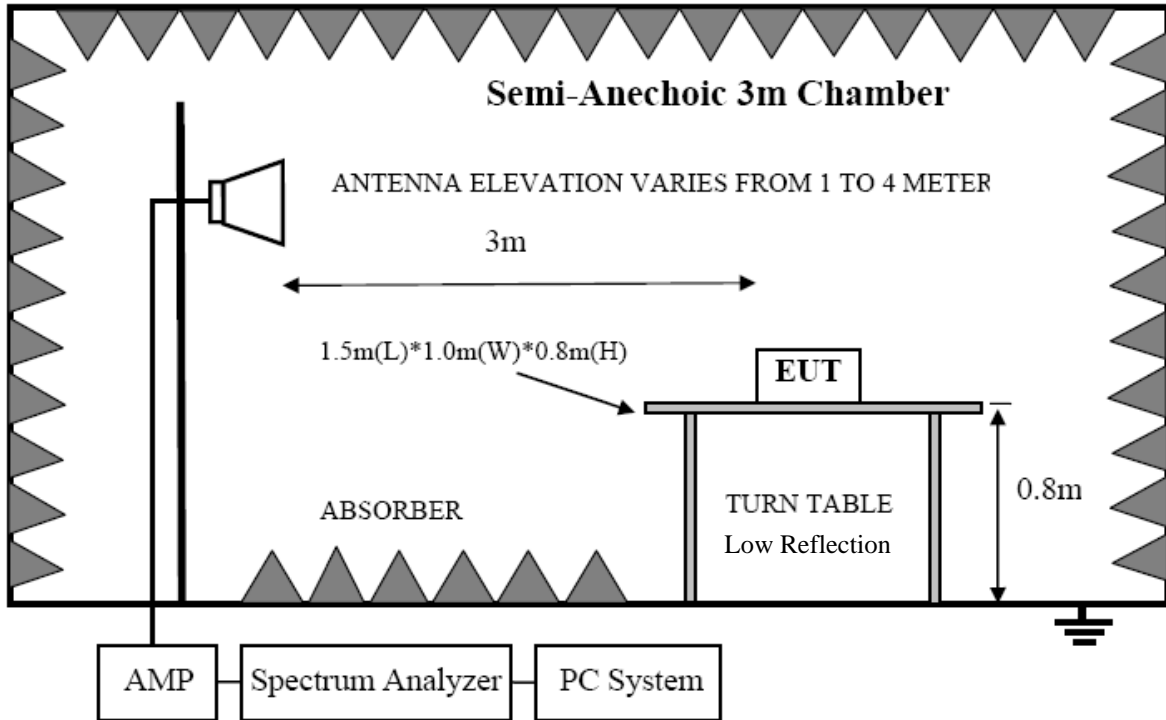

6.5. Limits

Frequency range Limits (GHz)	Limits of Class A, dB(μ V/m)		Limits of Class B, dB(μ V/m)	
	Peak	C/Average	Peak	C/Average
1 ~ 3	76	56	70	50
3 ~ 6	80	60	74	54

NOTE The lower limit shall apply at the transition frequency

6.6. Test procedure

The highest internal source of an EUT is defined as the highest frequency generated or used within the EUT or on which the EUT operates or tunes.

If the highest frequency of the internal sources of the EUT is less than 108 MHz, the measurement shall only be made up to 1 GHz.

If the highest frequency of the internal sources of the EUT is between 108 MHz and 500 MHz, the measurement shall only be made up to 2 GHz.

If the highest frequency of the internal sources of the EUT is between 500 MHz and 1 GHz, the measurement shall only be made up to 5 GHz.

If the highest frequency of the internal sources of the EUT is above 1 GHz, the measurement shall be made up to 5 times the highest frequency or 6 GHz, whichever is less.

For emissions above 1GHz, both Peak and Average level were measured with Spectrum Analyzer, and the RBW is set at 1MHz.

Measurements within 20 dB of the limit were then maximized by adjusting turntable position.

Final measurements were made using an C/Average detector.

Results checked manually and points close to the limit line were re-measured.

Pre-scan measurements were performed in all operating mode or resolution. But final measurements were performed in worst cases based on pre-scan measurements.

The EUT with following test modes were pre-tested:

No.	Test Voltage	Operation Mode	Cable Length	Resolution
1. *	230V 50Hz	Mode 1 HDMI1	1.8m	3840*2160@60Hz
2.			1.8m	1920*1080@60Hz
3.			1.8m	800*600@60Hz
4.		Mode 2 HDMI2	1.5m	3840*2160@60Hz
5.			1.5m	1920*1080@60Hz
6.			1.5m	800*600@60Hz
7.		HDMI1/2	1.8m	DVD
8.		Mode 3 DP	1.8m	3840*2160@60Hz
9.			1.8m	1920*1080@60Hz
10.			1.8m	800*600@60Hz
11.			1.5m	3840*2160@60Hz
12.		Mode 4 Type-C	1.8m	3840*2160@60Hz
13.			1.8m	1920*1080@60Hz
14.			1.8m	800*600@60Hz
15.			1.8m	Full Load
16.		1.5m	800*600@60Hz	
17.	230V 50Hz	HDMI1 3840*2160@60Hz with 1.5m power cord		
18.	110V 60Hz	HDMI1 3840*2160@60Hz		
19.	HDMI1 1920*1080@60Hz with headphone			
20.	HDMI1 1920*1080@60Hz without headphone			

* Means the worst test mode.

6.7. Test result

PASS. (See below detailed test result)

Note: All emissions not reported below are too low against the prescribed limits.

Operating Mode 1: HDMI1 IN

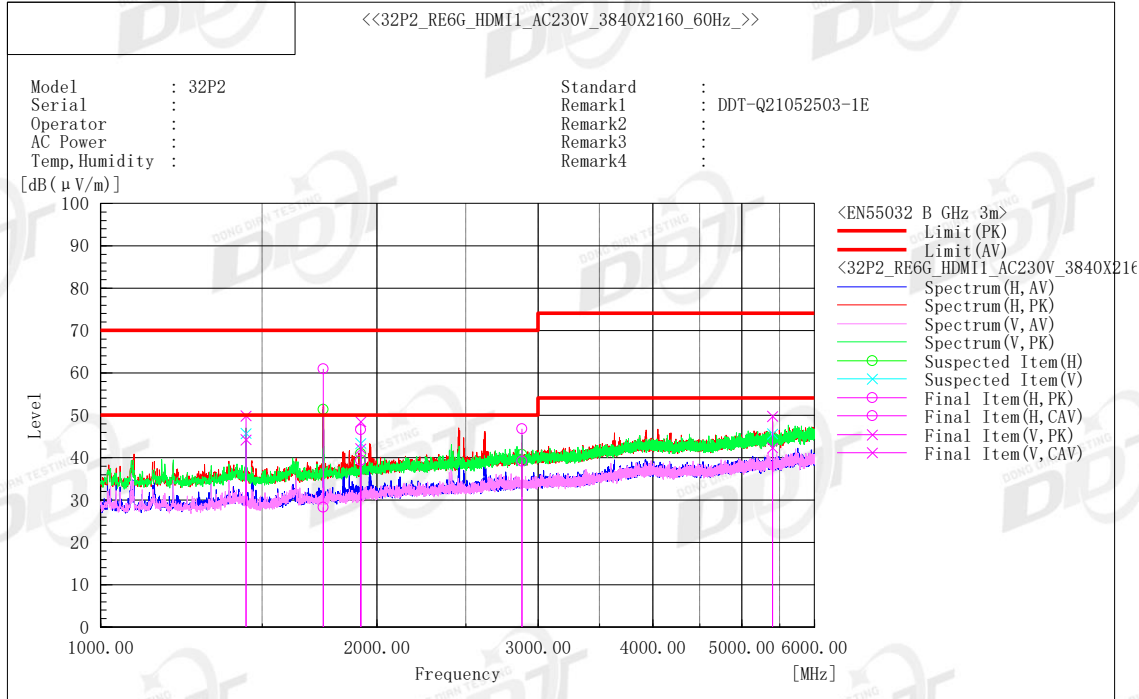

Final Result

No.	Frequency [MHz]	(P)	Reading PK [dB(µV)]	Reading CAV [dB(µV)]	c. f [dB(1/m)]	Result PK [dB(µV/m)]	Result CAV [dB(µV/m)]	Limit PK [dB(µV/m)]	Limit AV [dB(µV/m)]	Margin PK [dB]	Margin CAV [dB]	Height [cm]	Angle [°]
1	1748.649	H	77.2	44.5	-16.2	61.0	28.3	70.0	50.0	9.0	21.7	124.0	207.3
2	1440.056	V	67.2	61.6	-17.3	49.9	44.3	70.0	50.0	20.1	5.7	231.0	195.6
3	1920.083	V	63.8	57.4	-15.3	48.5	42.1	70.0	50.0	21.5	7.9	224.0	175.5
4	5399.998	V	56.5	49.0	-6.7	49.8	42.3	74.0	54.0	24.2	11.7	234.0	177.4
5	1920.063	H	61.9	54.7	-15.3	46.6	39.4	70.0	50.0	23.4	10.6	207.0	201.3
6	2880.088	H	59.9	52.3	-13.1	46.8	39.2	70.0	50.0	23.2	10.8	134.0	193.9

Note1) (P) : Abbreviation of Antenna Polarity

Note2) Reading PK / C/AV : Received raw Peak / C/Average signal

Note3) Factor = Antenna factor + Cable loss – Amplifier gain

Note4) Level PK / C/AV = Reading PK / C/AV + Factor, Real signal Peak / C/Average level

Note5) Margin PK / C/AV = Limit – Level PK / C/AV

PK : Abbreviation of Peak

C/AV : Abbreviation of CISPR Average

7. Harmonics current

7.1. General information

Test date	Jun. 04, 2021	Test engineer	Hoyt	
Climate condition	Ambient temperature	25.8±1°C	Relative humidity	43±1%
	Atmospheric pressure	99.6±0.2kPa		
Test place	Shield Room 1#			

7.2. Test equipment

Equipment	Manufacturer	Model No.	Serial No.	Last Cal.	Cal. Interval
Power Analyzer	N4L	PPA5511	162-04584	Jan. 13, 2021	1 year
Reference Impedance Network	Voltech	IEC61000-3	1G16412021	Jan. 13, 2021	1 year
AC Power Source	Pacific	360-AMX	1235	Mar. 02, 2021	1 year
AC Power Source	Pacific	360-AMX	1234	Mar. 02, 2021	1 year

Notes. N/A means Not applicable.

7.3. Reference standard

EN 61000-3-2:2014 (Class D)

EN IEC 61000-3-2:2019

BS EN 61000-3-2:2014

7.4. Block diagram of test setup

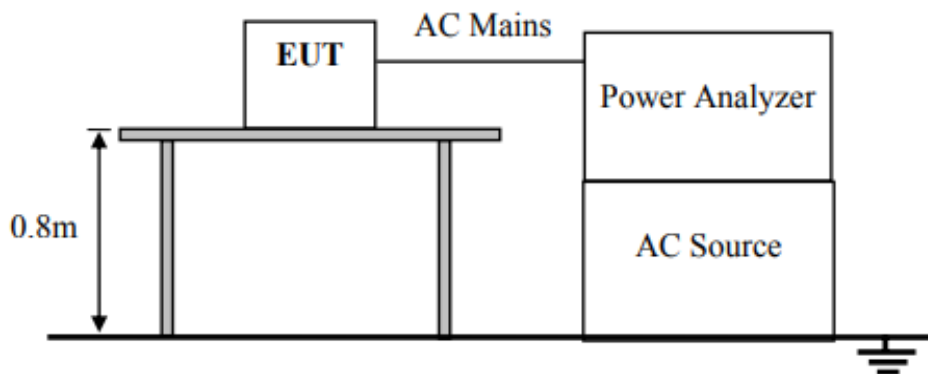

7.5. Limits

Limits for Class A equipment

Harmonic order n	Maximum permissible harmonic current A
Odd harmonics	
3	2.30
5	1.14
7	0.77
9	0.40
11	0.33
13	0.21
$15 \leq n \leq 39$ (odd harmonics only)	0.15 15/n
Even harmonics	
2	1.08
4	0.43
6	0.30
$8 \leq n \leq 40$	0.23 8/n

Limits for Class D equipment

Harmonic order n	Maximum permissible harmonic current per watt mA/W	Maximum permissible harmonic current A
3	3.4	2.30
5	1.9	1.14
7	1.0	0.77
9	0.5	0.40
11	0.35	0.33
$13 \leq n \leq 39$ (odd harmonics only)	3.85/n	See Table 1

7.6. Test result

PASS. (See below detailed test result)

Operating Mode 1: HDMI1 IN

04th June 2021 - 14:02:11		Page 1/6	IEC Soft V2.4e
		IEC61000-3-2:2014 Fluctuating Harmonics	
Instrument Details			
Instrument Model	PPA5511		
Instrument Serial	162-04584		
Instrument Firmware	2.17		
Instrument Version	Low Current		
Test Settings			
Class	Class D		
Mode	Measure		
Equipment Under Test			
Brand	N/A		
Model	**32P2*****		
Serial	N/A		
Impedance Network ID	N/A		
Test Conditions			
	User Entered	Measured	
Rated Voltage	230.000 V	231.022 V	
Rated Current	N/A	472.800 mA	
Rated Frequency	50.000 Hz	50.000 Hz	
Rated Power	N/A	102.741 W	
Additional Test Information			
Measured Power Factor	0.9406		
Max Current THD	22.34%		
Max THC	0.1009A		
Max Power	102.952 W		
Max F.Current	462.001 mA		
Average F.Current	461.294 mA		
Minimum Current	100mA		
Test Duration	2.5 minutes		
Additional Test Details			
Operator	N/A		
Lab Name	N/A		
Location	N/A		
Notes			
Signature			
Results	PASS		

04th June 2021 - 14:02:11			Ph:1 Page 2/6			IEC Soft V2.4e	
IEC61000-3-2:2014 Fluctuating Harmonics							
Instrument Details							
Instrument Model		PPA5511					
Instrument Serial		162-04584					
Instrument Firmware		2.17					
Equipment Under Test							
Brand		N/A					
Model		**32P2*****					
Serial		N/A					
Harmonic Difference							
Harmonic	Lowest		Highest		Limit		Status
	Average (A)	Test #	Average (A)	Test #	Allowance (A)	Difference (A)	
2	0.00078	1	0.00081	2	0	0.00003	PASS
3	0.091957	2	0.092277	1	0.017464	0.00032	PASS
4	0.000238	2	0.000271	1	0	0.000033	PASS
5	0.036372	2	0.036477	1	0.009759	0.000105	PASS
6	0.000234	2	0.000245	1	0	0.000011	PASS
7	0.016988	2	0.017089	1	0.005136	0.000101	PASS
8	0.000208	2	0.000216	1	0	0.000008	PASS
9	0.002403	1	0.00257	2	0.002568	0.000168	PASS
10	0.000215	1	0.000225	2	0	0.00001	PASS
11	0.004051	2	0.004128	1	0.001798	0.000077	PASS
12	0.00021	2	0.000227	1	0	0.000017	PASS
13	0.004529	2	0.004674	1	0.001521	0.000145	PASS
14	0.000199	2	0.000203	1	0	0.000004	PASS
15	0.004523	1	0.004627	2	0.001318	0.000105	PASS
16	0.000213	1	0.000217	2	0	0.000004	PASS
17	0.003438	1	0.003562	2	0.001163	0.000124	PASS
18	0.000254	2	0.000291	1	0	0.000036	PASS
19	0.001368	1	0.001474	2	0.001041	0.000106	PASS
20	0.000202	2	0.000212	1	0	0.00001	PASS
21	0.001668	1	0.001712	2	0.000942	0.000044	PASS
22	0.000307	1	0.000315	2	0	0.000009	PASS
23	0.003858	1	0.003959	2	0.00086	0.0001	PASS
24	0.000216	2	0.000232	1	0	0.000016	PASS
25	0.004117	1	0.00418	2	0.000791	0.000064	PASS
26	0.000223	2	0.000223	1	0	0.000001	PASS
27	0.002219	1	0.00222	2	0.000732	0.000001	PASS
28	0.000199	2	0.000213	1	0	0.000014	PASS
29	0.00254	1	0.002703	2	0.000682	0.000163	PASS
30	0.000232	1	0.000242	2	0	0.00001	PASS
31	0.004679	2	0.004716	1	0.000638	0.000037	PASS
32	0.000218	1	0.000218	2	0	0	PASS
33	0.003218	2	0.003329	1	0.000599	0.000111	PASS
34	0.000193	2	0.000203	1	0	0.00001	PASS
35	0.000835	1	0.000984	2	0.000565	0.000149	PASS
36	0.000221	1	0.00023	2	0	0.000009	PASS
37	0.003547	2	0.003674	1	0.000534	0.000127	PASS
38	0.000257	2	0.000273	1	0	0.000017	PASS
39	0.002284	2	0.002444	1	0.000507	0.00016	PASS
40	0.000227	1	0.000266	2	0	0.00004	PASS

Key:

Allowance	Maximum Difference allowed in Amps
Good	The difference is less than 50% of the allowance
OK	The difference is between 50% of the allowance and 75% of the allowance
Poor	The difference is between 75% of the allowance and 100% of the allowance
Fail	The difference has exceeded the allowance

8. Voltage fluctuation & Flicker

8.1. General information

Test date	Jun. 04, 2021	Test engineer	Hoyt	
Climate condition	Ambient temperature	25.8±1℃	Relative humidity	43±1%
	Atmospheric pressure	99.6±0.2kPa		
Test place	Shield Room 1#			

8.2. Test equipment

Equipment	Manufacturer	Model No.	Serial No.	Last Cal.	Cal. Interval
Power Analyzer	N4L	PPA5511	162-04584	Jan. 13, 2021	1 year
Reference Impedance Network	Voltech	IEC61000-3	1G16412021	Jan. 13, 2021	1 year
AC Power Source	Pacific	360-AMX	1235	Mar. 02, 2021	1 year
AC Power Source	Pacific	360-AMX	1234	Mar. 02, 2021	1 year

Notes. N/A means Not applicable.

8.3. Reference standard

EN 61000-3-3:2013
 EN 61000-3-3:2013+A1:2019
 BS EN 61000-3-3:2013

8.4. Block diagram of test setup

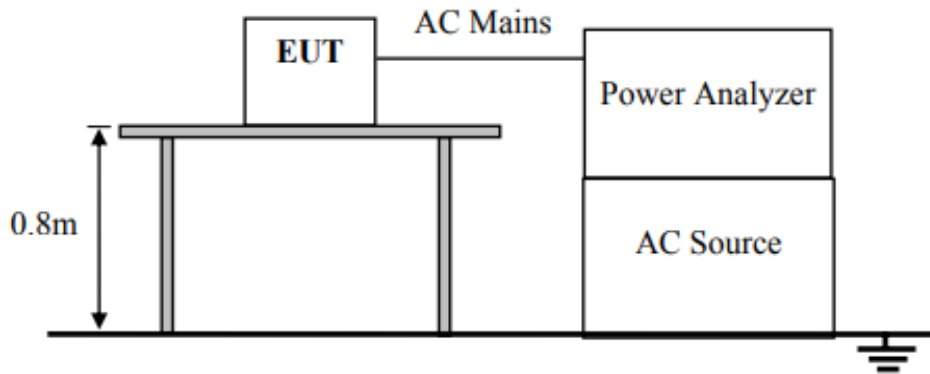

8.5. Limits

short-term flicker indicator, Pst	the relative steady-state voltage change, dc	the value of $d(t)$ during a voltage change, $d(t) > 3.3\%$	the maximum relative voltage change, d_{max}
1.0	3.3 %	500 ms	4 %

8.6. Test result

PASS. (See below detailed test result)

Operating Mode 1: HDMI1 IN

04th June 2021 - 14:10:24

Page 1/2

IEC Soft V2.4e

IEC61000-3-3:2013 Ed.3.0 Flickermeter		
Instrument Details		
Instrument Model	PPA5511	
Instrument Serial	162-04584	
Instrument Firmware	2.17	
Instrument Version	Low Current	
Test Settings		
Class	Voltage	
Mode	Normal - 4%	
Minimum Current	300mA	
PST	N/A - Inrush Test Only	
PLT	N/A - Inrush Test Only	
Equipment Under Test		
Brand	N/A	
Model	**32P2*****	
Serial	N/A	
Impedance Network ID	N/A	
Test Conditions		
	User Entered	Measured
Rated Voltage	230.000 V	231.070 V
Rated Current	N/A	N/A
Rated Frequency	50.000 Hz	50.000 Hz
Rated Power	N/A	N/A
D max	N/A - Inrush Test Only	
T max	N/A - Inrush Test Only	
DC max	N/A - Inrush Test Only	
Inrush Test	0.4957% (Limit: 4%)	
Additional Test Details		
Operator	N/A	
Lab Name	N/A	
Location	N/A	
Notes		
Signature		
Results	Phase1: PASS	

04th June 2021 - 14:10:24		Ph:1 Page 2/2		IEC Soft V2.4e	
IEC61000-3-3:2013 Ed.3.0 Flickermeter					
Instrument Details					
Instrument Model		PPA5511			
Instrument Serial		162-04584			
Instrument Firmware		2.17			
Equipment Under Test					
Brand		N/A			
Model		**32P2*****			
Serial		N/A			
Inrush Current Results					
Test Number	Dmax (%)	Running Average (%)	Status		
1	0.57969	0.57969	OK		
2	0.15606	0.367875	OK		
3	0.47019	0.40198	OK		
4	0.33233	0.384568	OK		
5	0.40491	0.388636	OK		
6	0.67913	0.388636	Highest		
7	0.13911	0.347048	OK		
8	0.53895	0.374463	OK		
9	0.59977	0.402626	OK		
10	0.53185	0.416984	OK		
11	0.1154	0.416984	Lowest		
12	0.42052	0.417338	OK		
13	0.55898	0.430215	OK		
14	0.66406	0.449702	OK		
15	0.62187	0.462945	OK		
16	0.56747	0.470411	OK		
17	0.6373	0.481537	OK		
18	0.40633	0.476837	OK		
19	0.49347	0.477815	OK		
20	0.59449	0.484297	OK		
21	0.46992	0.483541	OK		
22	0.60134	0.48943	OK		
23	0.56956	0.493246	OK		
24	0.54619	0.495653	OK		

Key	
Above Limit	
Lowest Dmax	
Highest Dmax	

9. Electrostatic Discharge

9.1. General information

Test date	Jun. 04, 2021	Test engineer	Novak	
Climate condition	Ambient temperature	25.4±1°C	Relative humidity	47±1%
	Atmospheric pressure	100.9±0.2kPa		
Test place	Shield Room 3#			

9.2. Test equipment

Equipment	Manufacturer	Model No.	Serial No.	Last Cal.	Cal. Interval
ESD Generator	TESEQ	NSG 438	1040	Oct. 09, 2020	1 Year

9.3. Test and reference standards

IEC-61000-4-2:2008

BS EN 61000-4-2:2009

9.4. Block diagram of test setup

(1) Table-top equipment

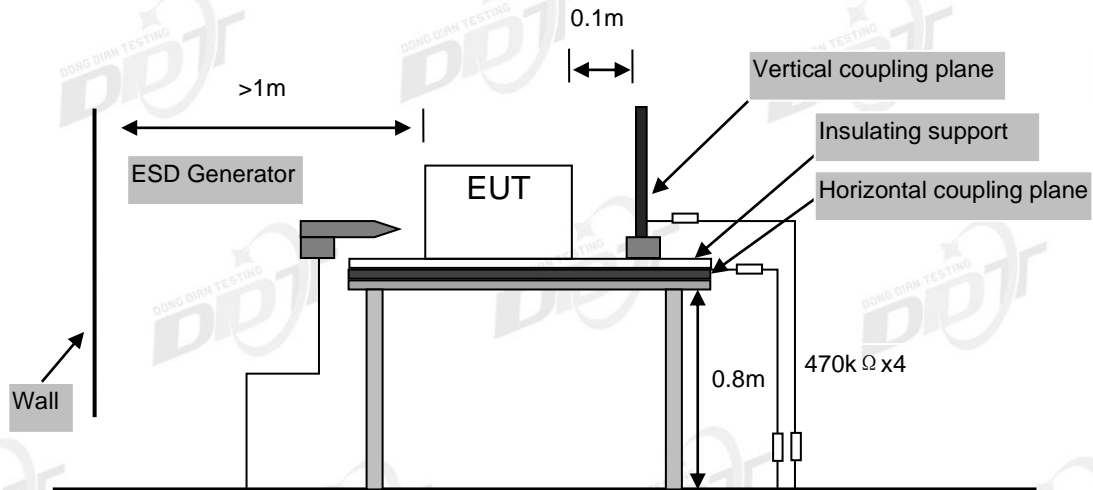

(2) Floor-standing equipment

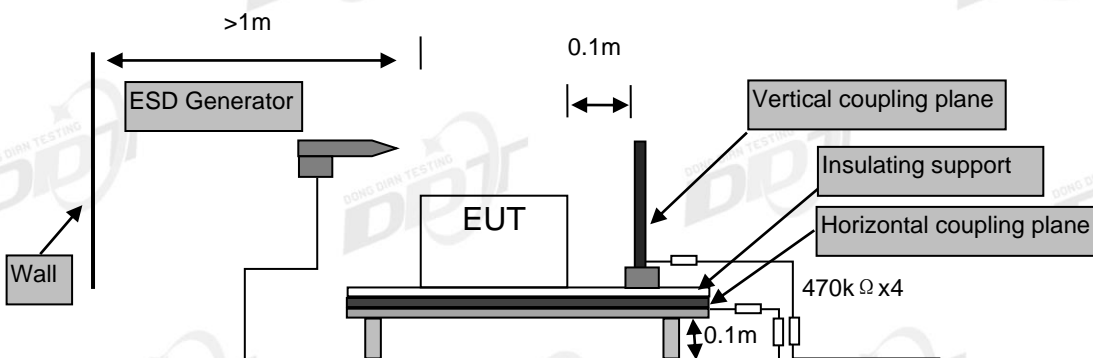

9.5. Test levels and performance criterion

Test Level		Performance Criteria
Air Discharge	$\pm 2\text{kV}$, $\pm 4\text{kV}$ and $\pm 8\text{kV}$	B
Contact Discharge	$\pm 4\text{kV}$	

Performance criteria B description: During the test, degradation of performance is allowed. However, no change of operating state or stored data is allowed to persist after the test. After the test, the EUT shall continue to operate as intended without operator intervention. No degradation of performance or loss of function is allowed, after the application of the phenomena below a performance level specified by the manufacturer, when the EUT is used as intended.

9.6. Test procedure

Air Discharge:

The test was applied on non-conductive surfaces of EUT. The round discharge tip of the discharge electrode was approached as fast as possible to touch the EUT. After each discharge, the discharge electrode was removed from the EUT. The generator was re-triggered for a new single discharge and repeated 20 times for each pre-selected test point. This procedure was repeated until all the air discharge completed.

Contact Discharge:

All the procedure was same as air discharge. Except that the generator was re-triggered for a new single discharge. The tip of the discharge electrode was touching the EUT before the discharge switch was operated.

Indirect discharge for horizontal coupling plane:

At least 20 single discharges were applied to the horizontal coupling plane, at points on each side of the EUT. The discharge electrode positions vertically at a distance of 0.1m from the EUT and with the discharge electrode touching the coupling plane.

Indirect discharge for vertical coupling plane:

At least 20 single discharges were applied to the center of one vertical edge of the coupling plane. The coupling plane, of dimensions 0.5m X 0.5m, was placed parallel to, and positioned at a distance of 0.1m from the EUT. Discharges were applied to the coupling plane, with this plane in sufficient different positions that the four faces of the EUT are completely illuminated.

9.7. Test result

Power supply: AC 230V/50Hz, AC 110V/60Hz						
Test Times: 20 times at each point for contact discharge; 20 times at each point for air discharge.						
Operation Mode	Type of discharge	Test Level	Test Point	Performance		Result
				Required	Observation	(Pass/Fail)
Mode 2	Contact to EUT	±4kV	4,6,8,9,10,11,12	B	A	Pass
	Contact to Coupling Planes	±4kV	Coupling Planes	B	A	Pass
	Air	±2kV, ±4kV, and ±8kV	1,2,3,4,5,6,7,8,9,10,11	B	A	Pass
Test Point:						
No.	Description	No.	Description	No.	Description	
1	Panel	6	HDMI1 Port	11	AUDIO Port	
2	Button	7	HDMI2 Port	12	Shielded Cover	
3	Gap	8	DP Port	13		
4	USB Port	9	Type-C Port	14		
5	Switch	10	USB-B Port	15		
Observation Description:						
A: Operation as intend, no loss of function during test and after test.						

Photo of ESD point on EUT

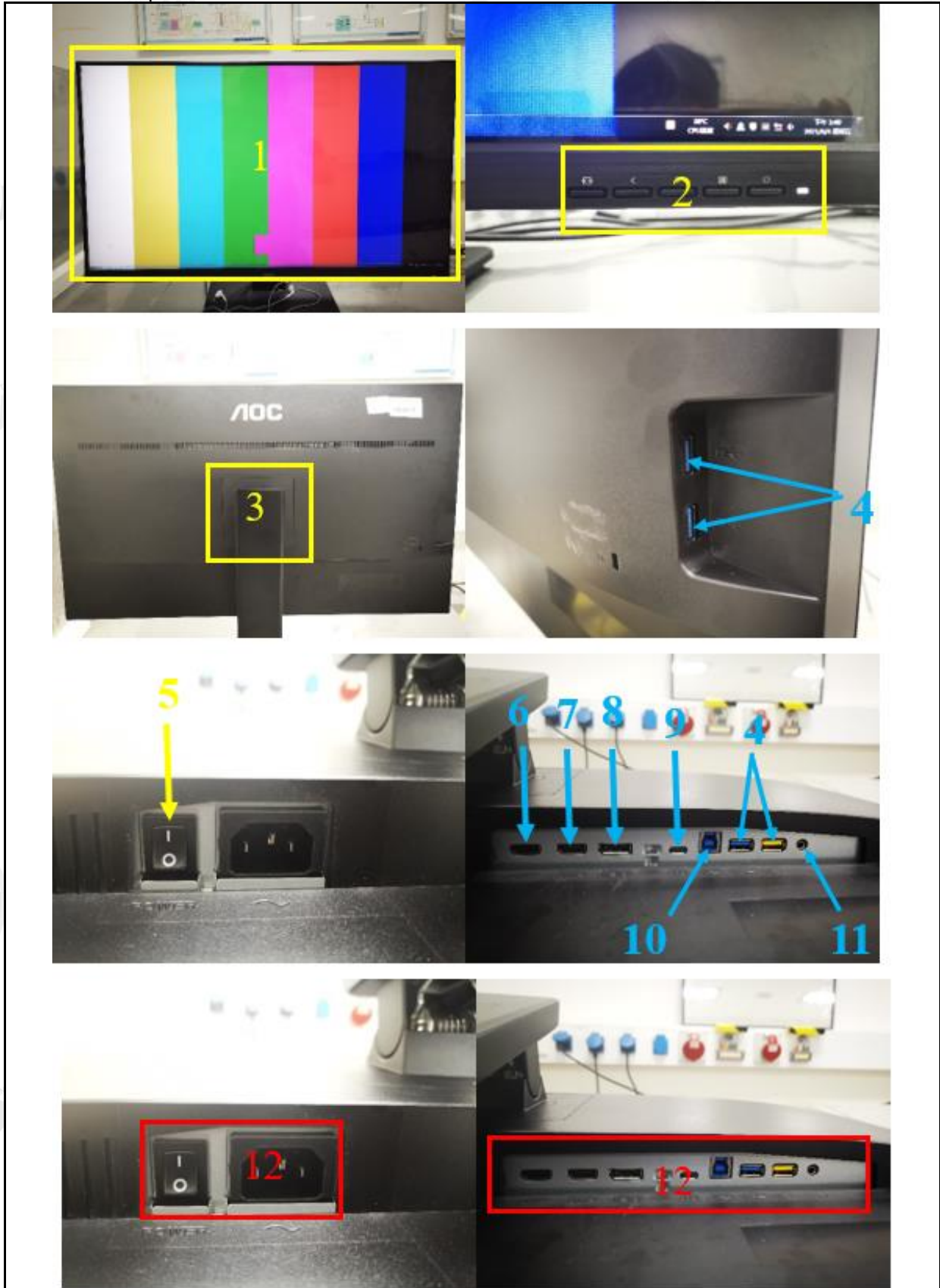

10. Continuous Radio Frequency Disturbances

10.1. General information

Test date	Jun. 08, 2021	Test engineer	Thomas	
Climate condition	Ambient temperature	24.2±1°C	Relative humidity	31±1%
	Atmospheric pressure	100.1±0.2kPa		
Test place	RS Chamber			

10.2. Test equipment

Equipment	Manufacturer	Model No.	Serial No.	Last Cal.	Cal. Interval
Signal Generator	R&S	SMB100A	104909	Mar. 02, 2021	1 Year
Amplifier	BONN	BLMA 1060-250	1811750	Sep. 23, 2020	1 Year
Amplifier	TESEQ	CBA 1G-1200B	V2303-0618	Sep. 23, 2020	1 Year
Power meter	R&S	NRP	102424	Mar. 02, 2021	1 Year
Power sensor	R&S	NRP-Z91	100937	Mar. 02, 2021	1 Year
Power sensor	R&S	NRP-Z91	100938	Mar. 02, 2021	1 Year
Log-periodic antenna	Schwarzbeck	STLP 9149	9149-059	N/A	N/A
Log-periodic antenna	Schwarzbeck	STLP 9128 E special	9128ES-171	N/A	N/A
Audio Analyzer	R&S	UPV	101525	Mar. 08, 2021	1 Year

10.3. Test and reference standards

IEC 61000-4-3:2006+A1:2007+A2:2010

BS EN 61000-4-3:2006+A1:2008+A2:2010

10.4. Block diagram of test setup

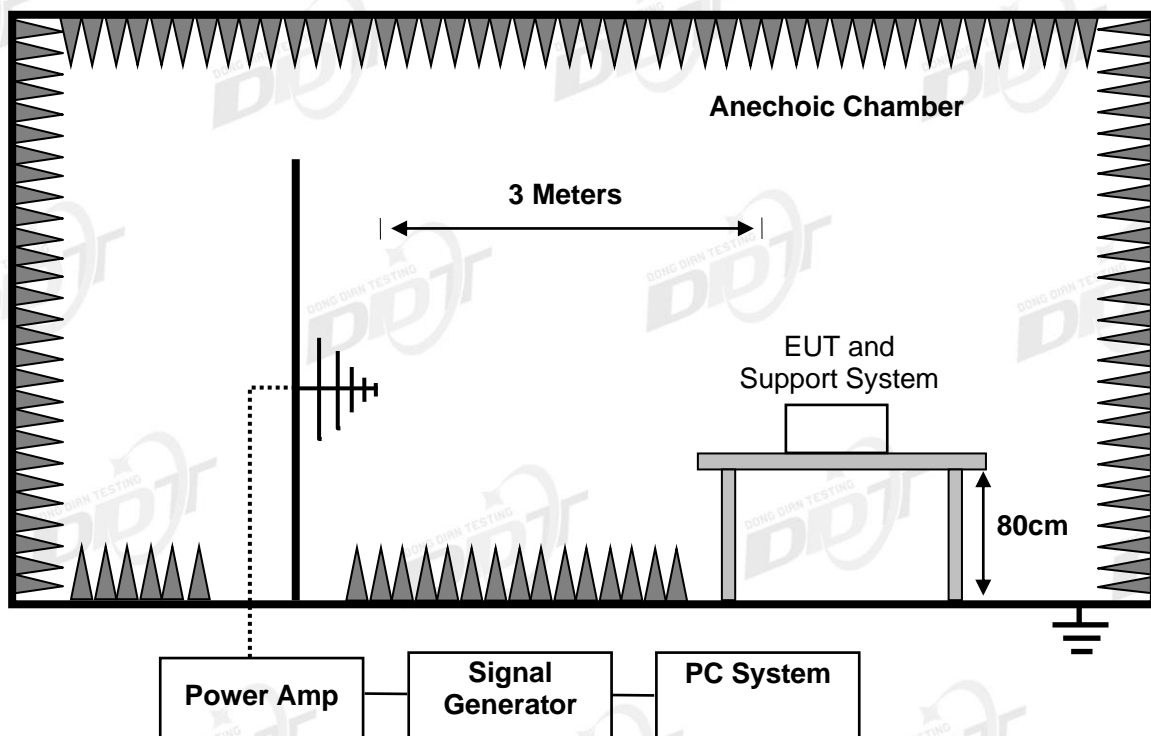

10.5. Test levels and performance criterion

Swept frequency test		Performance Criteria
Frequency (MHz)	80 to 1000	A
Field Strength	3V/m rms voltage level of the unmodulated signal	
Modulation	AM modulated to a depth of 80% by a sine wave of <input checked="" type="checkbox"/> 1kHz, <input type="checkbox"/> 400Hz (note 1)	
Step Size	1% increments	
Dwell time	< 5 Sec.	

Spot frequency test		Performance Criteria
Frequency (MHz)	1800, 2600, 3500, 5000	A
Field Strength	3V/m rms voltage level of the unmodulated signal	
Modulation	AM modulated to a depth of 80% by a sine wave of <input checked="" type="checkbox"/> 1kHz, <input type="checkbox"/> 400Hz (note 1)	
Dwell time	< 5 Sec.	

Note 1: The 1kHz modulation may be replaced by a different audio modulation frequency more appropriate for a given EUT if, for example, 1kHz is not within the operating audio range of the EUT.

Performance criteria A description for devices with the audio output function: The measured acoustic interference ratio and/or the measured electrical interference ratio during the test shall be -20 dB or better.

For equipment with audio output function:

- The acoustic measurement method was selected according to clause G6.4.1 of EN 55035.
- The electrical measurement method was selected according to clause G6.4.2 of EN 55035.

Performance criteria A for devices with the telephony function.

Frequency range MHz	Acoustic or electrical interference ratio	Equivalent direct measurement		
		dB(SPL)	Digital dBm0	Analogue dBm0
80 to 1000	-0 dB	75	-30	-30

Note: At the step in the frequency range, the lower limit shall be applied.

The interference ratio (electrical or acoustic) shall meet the limits in column 2; or,
The acoustic level of the demodulated audio shall be less than the limits in column 3; or
The digitally coded level of demodulated audio shall be less than limits in column 4; or,
The analogue level of the demodulated audio shall be less than the limits in column 5.

Performance criteria A description for other devices: During and after the test the EUT shall continue to operate as intended without operator intervention. No degradation of performance or loss of function is allowed below a minimum performance level specified by the manufacturer when the EUT is used as intended.

10.6. Test procedure

The field sensor is placed on the EUT table (0.8 meter above the ground) which is 3 meters away from the transmitting antenna. Through the signal generator, power amplifier and transmitting antenna to produce a uniformity field strength (3V/m measured by field sensor) around the EUT table from frequency range specified and records the signal generator's output level at the same time for whole measured frequency range. Then, put EUT and its simulators on the EUT turn table and keep them 3 meters away from the transmitting antenna which is mounted on an antenna tower and fixes at 1.4 meter height above the ground. Using the recorded signal generator's output level to measure the EUT from frequency range specified and both horizontal & vertical polarization of antenna must be set and measured. Each of the four sides of EUT must be faced this transmitting antenna and measures individually.

10.7. Test result

Power supply: <u>AC 230V/50Hz, AC 110V/60Hz</u>						
Field Strength : <input checked="" type="checkbox"/> 3V/m <input type="checkbox"/> 10V/m Steps: <input checked="" type="checkbox"/> 1% <input type="checkbox"/> other: Dwell time: <input checked="" type="checkbox"/> 1s <input type="checkbox"/> other:						
Swept Frequency Range: <input checked="" type="checkbox"/> 80MHz---1GHz; <input checked="" type="checkbox"/> 1800MHz, 2600MHz, 3500MHz, 5000MHz; <input type="checkbox"/> other:						
Modulation : <input type="checkbox"/> None <input checked="" type="checkbox"/> AM <input checked="" type="checkbox"/> 1kHz <input type="checkbox"/> 400Hz Modulation depth: <input checked="" type="checkbox"/> 80% <input type="checkbox"/> other:						
Operation Mode	EUT Position towards antenna	Antenna: Horizontal		Antenna: Vertical		Result (Pass/Fail)
		Required	Observation	Required	Observation	
Mode 2	Front	A	A	A	A	Pass
	Right	A	A	A	A	Pass
	Rear	A	A	A	A	Pass
	Left	A	A	A	A	Pass
Mode2:Audio output: electrical interference ratio= <u>-39.56</u> dB ≤-20dB. Mode2:Speaker: Acoustic interference ratio= <u>-40.03</u> dB ≤-20dB. Note 1: this row only for the device with audio output function. Note 2: this device without the telephony function.						
Observation Description: A: Operation as intend, no loss of function during test and after test.						

11. Electrical Fast Transients (EFT)

11.1. General information

Test date	Jun. 04, 2021	Test engineer	Novak	
Climate condition	Ambient temperature	25.4±1°C	Relative humidity	47±1%
	Atmospheric pressure	100.9±0.2kPa		
Test place	Shield Room 3#			

11.2. Test equipment

Equipment	Manufacturer	Model No.	Serial No.	Last Cal.	Cal. Interval
EFT Generator	TESEQ	NSG3060	210	Mar. 04, 2021	1 Year
Coupling/Decoupling Network	TESEQ	CDN3061	210	Mar. 04, 2021	1 Year

11.3. Test and reference standards

IEC-61000-4-4:2012

BS EN 61000-4-4:2012

11.4. Block diagram of test setup

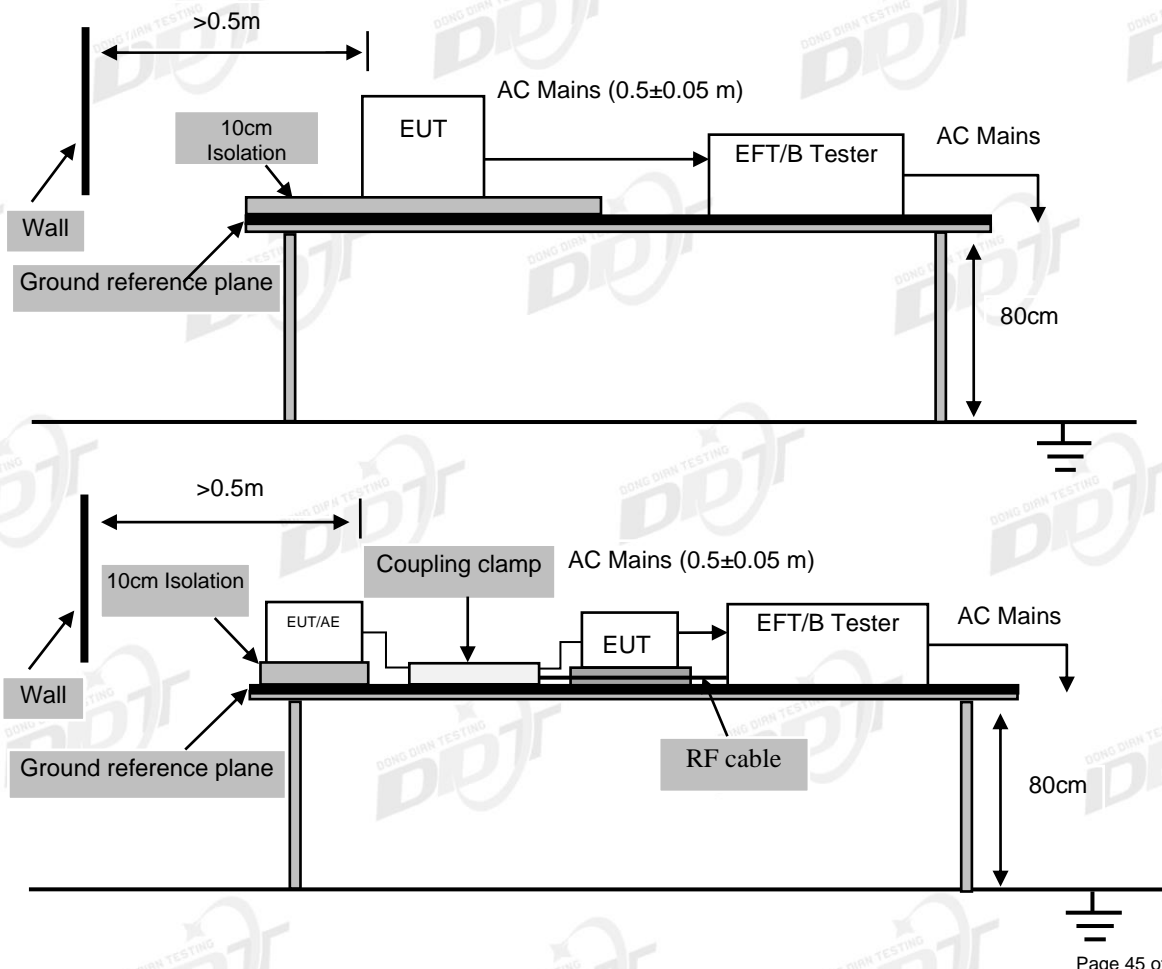

11.5. Test levels and performance criterion

Test Level			Performance Criteria
Test voltage	±1kV For AC mains Port	±0.5kV for DC input or signal Port	B
Repetition Frequency	5kHz	5kHz	
Burst Duration	15ms	15ms	
Burst Period	300ms	300ms	
Inject Time(s)	120s	120s	
Inject Method	Direct for AC mains port	Direct for signal port Direct for dc input port	
Inject Line	AC Mains of adapter	DC input of adapter or Capacitive coupling clamp	

Note: This test shall be additionally performed on analogue/digital data ports, and DC network power ports, of radio equipment and associated ancillary equipment, if the cables may be longer than 3 m.

Performance criteria B description: During the test, degradation of performance is allowed. However, no change of operating state or stored data is allowed to persist after the test. After the test, the EUT shall continue to operate as intended without operator intervention. No degradation of performance or loss of function is allowed, after the application of the phenomena below a performance level specified by the manufacturer, when the EUT is used as intended.

11.6. Test Procedure

The EUT and its simulators were placed on the ground reference plane and were insulated from it by a wood support 0.1m ± 0.01m thick. The ground reference plane was 1m*1m metallic sheet with 0.65mm minimum thickness. This reference ground plane was project beyond the EUT by at least 0.1m on all sides and the minimum distance between EUT and all other conductive structure, except the ground plane was more than 0.5m. All cables to the EUT was placed on the wood support, cables not subject to EFT/B was routed as far as possible from the cable under test to minimize the coupling between the cables.

For DC input and AC power ports:

The EUT was connected to the power mains by using a coupling device that couples the EFT interference signal to AC power lines. Both positive transients and negative transients of test voltage were applied during compliance test and the duration of the test can't less than 2mins.

For signal ports:

The capacitive coupling clamp was connected to the power by using a coupling device that couples the EFT interference signal to capacitive coupling clamp. Both positive transients and negative transients of test voltage were applied during compliance test and the duration of the test can't less than 2mins.

11.7. Test result

Power supply: AC 230V/50Hz, AC 110V/60Hz						
Port <input checked="" type="checkbox"/> AC Mains <input type="checkbox"/> DC Supply <input type="checkbox"/> Signal			Burst Period: <input checked="" type="checkbox"/> 300ms <input type="checkbox"/> Other:			
Coupling: <input checked="" type="checkbox"/> Direct <input type="checkbox"/> Capacitive Clamp			Test Time: <input checked="" type="checkbox"/> 120S <input type="checkbox"/> Other:			
Repetition Frequency: <input checked="" type="checkbox"/> 5KHz <input type="checkbox"/> Other:			Burst Durations: <input checked="" type="checkbox"/> 15ms <input type="checkbox"/> Other:			
Operation Mode	Line/port	Test Voltage	Performance			Result (Pass/Fail)
			Required	Observation (+)	Observation (-)	
Mode 1	L	±1kV	B	A	A	Pass
	N	±1kV	B	A	A	Pass
	L-N	±1kV	B	A	A	Pass
	PE	±1kV	B	A	A	Pass
	L-PE	±1kV	B	A	A	Pass
	N-PE	±1kV	B	A	A	Pass
	L-N-PE	±1kV	B	A	A	Pass
Observation Description: A: Operation as intend, no loss of function during test and after test.						

12. Surges

12.1. General information

Test date	Jun. 04, 2021	Test engineer	Novak	
Climate condition	Ambient temperature	25.4±1°C	Relative humidity	47±1%
	Atmospheric pressure	100.9±0.2kPa		
Test place	Shield Room 3#			

12.2. Test equipment

Equipment	Manufacturer	Model No.	Serial No.	Last Cal.	Cal. Interval
Surge Generator	TESEQ	NSG3060	210	Mar. 04, 2021	1 Year
Coupling/Decoupling Network	TESEQ	CDN3061	210	Mar. 04, 2021	1 Year
Surge Impulse Module	TESEQ	CWM3650	196	Mar. 04, 2021	1 Year

12.3. Test and reference standards

IEC-61000-4-5:2014

BS EN 61000-4-5:2014+A1:2017

12.4. Block diagram of test setup

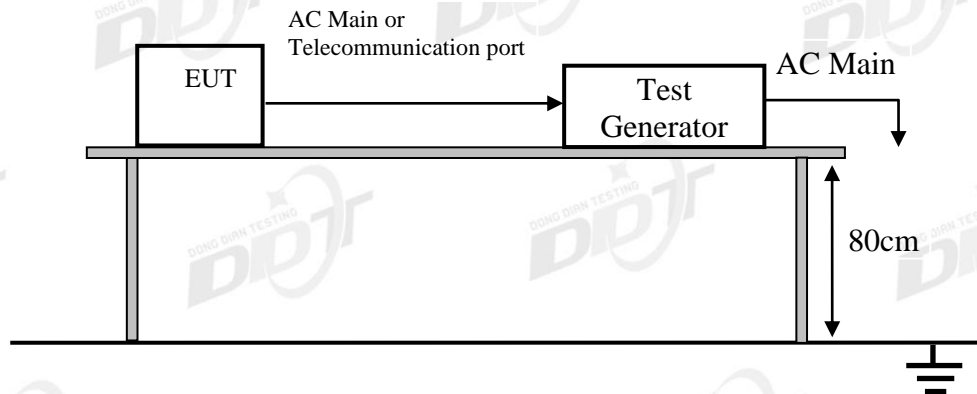

12.5. Test levels and performance criterion

Test level for AC mains ports		Performance Criterion
Line to Line	1kV 1.2/50(8/20) μs	B
Line to Ground	2kV 1.2/50(8/20) μs	B
Analogue/digital data port, Port type: unshielded symmetrical		Performance Criterion
Line to Ground	1 kV and 4kV 10/700(5/320) μs (used with the primary protection)	C

Line to Ground	1 kV 10/700(5/320) μ s (used without the primary protection)	C
Note: Applicable only to ports which, according to the manufacturer's specification, the cable lengths greater than 3m.		
Analogue/digital data port, Port type: coaxial or shielded		Performance Criterion
Shield to ground	0.5 kV 1.2/50(8/20) μ s	B
Note: Applicable only to ports which, according to the manufacturer's specification, the cable lengths greater than 3m.		
DC network power port		Performance Criterion
Line to reference ground	0.5 kV 1.2/50(8/20) μ s	B
Note: Applicable only to ports which, according to the manufacturer's specification, 1. The cable lengths greater than 3m; 2. May connect directly to outdoor cables.		

Performance criteria B description: During the test, degradation of performance is allowed.

However, no change of operating state or stored data is allowed to persist after the test. After the test, the EUT shall continue to operate as intended without operator intervention. No degradation of performance or loss of function is allowed, after the application of the phenomena below a performance level specified by the manufacturer, when the EUT is used as intended.

12.6. Test Procedure

For line-to-neutral coupling mode, provide a 0.5 kV/1 kV 1.2/50 μ s voltage surge (at open-circuit condition) and 8/20 μ s current surge to EUT selected points.

For line-to-ground coupling mode, provide a 0.5 kV/1 kV/2 kV 1.2/50 μ s voltage surge (at open-circuit condition) and 8/20 μ s current surge to EUT selected points.

The number of pulses applied shall be as follows:

- Five positive pulses line-to-neutral at 90° phase
- Five negative pulses line-to-neutral at 270° phase

The following additional pulses are required only if the EUT has an earth connection or if the EUT is earthed via any AE.

- Five positive pulses line-to-earth at 90° phase
- Five negative pulses line-to-earth at 270° phase
- Five negative pulses neutral-to-earth at 90° phase
- Five positive pulses neutral-to-earth at 270° phase

Maximum 1/min repetition rate are applied during test.

Different phase angles are done individually.

For telecommunication surge test, each line of internet port to ground coupling mode, provide a 1.0kV 10/700 μ s voltage surge (at open-circuit condition) and 5/320 μ s current surge to EUT selected points.

At least 5 positive and 5 negative (polarity) tests with a maximum 1/min repetition rate are applied during test.

Record the EUT operating situation during compliance test and decide the EUT immunity criterion for above each test.

12.7. Test result

Power supply: <u>AC 230V/50Hz, AC 110V/60Hz</u>											
Line: <input checked="" type="checkbox"/> AC Mains <input type="checkbox"/> DC Supply <input type="checkbox"/> Telecommunication port <input type="checkbox"/> Signal port											
Wave Type: <input checked="" type="checkbox"/> 1.2/50us-8/20us <input type="checkbox"/> 10/700 us-5/320us Internal impedance: <input checked="" type="checkbox"/> 2Ω <input checked="" type="checkbox"/> 12Ω <input type="checkbox"/> 25Ω <input type="checkbox"/> 40Ω <input type="checkbox"/> 160Ω											
Pulse times: 5 times at each polarity Pulse Interval: 60S Voltage Phase: <input type="checkbox"/> 0°, 90°, 180°, 270° <input checked="" type="checkbox"/> 90°, 270°											
Operation Mode	Line/Port	0.5kV			1kV			2kV			Result
		Required	Observation		Required	Observation		Required	Observation		
	+		-			+	-			+	-
Mode 1	L-N	B	A	A	B	A	A	/	/	/	Pass
	L-Pe	B	A	A	B	A	A	B	A	A	Pass
	N-Pe	B	A	A	B	A	A	B	A	A	Pass
Observation Description: A: Operation as intend, no loss of function during test and after test.											

13. Continuous Conducted Disturbances

13.1. General information

Test date	Jun. 04, 2021	Test engineer	Novak	
Climate condition	Ambient temperature	25.4±1°C	Relative humidity	47±1%
	Atmospheric pressure	100.9±0.2kPa		
Test place	Shield Room 3#			

13.2. Test Equipment

Equipment	Manufacturer	Model No.	Serial No.	Last Cal.	Cal. Interval
Signal Generator	R&S	SMB100A	103231	Mar. 02, 2021	1 Year
CDN	TESEQ	CDN M016	28987	Mar. 02, 2021	1 Year
Audio Analyzer	R&S	UPV	101525	Mar. 08, 2021	1 Year
RF Power Amplifiers	BONN	BSA1515-25	097784	Jun. 05, 2020	1 Year
Test Software	R&S	EMC 32	Ver 10.28.0	N/A	N/A

13.3. Test and reference standards

IEC-61000-4-6:2013

BS EN 61000-4-6:2014

13.4. Block diagram of test setup

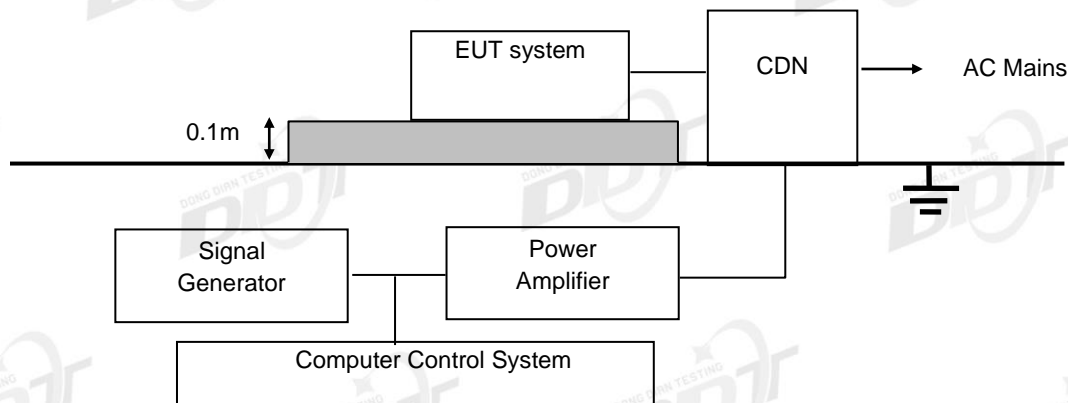

For audio output function (electrical measurement, direct connection to EUT)

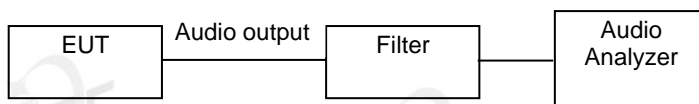

For audio output function (acoustic measurement)

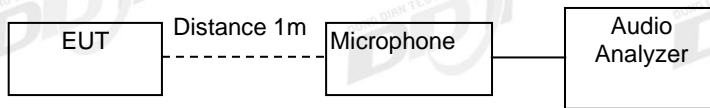

For audio output function (on-ear acoustic measurement)

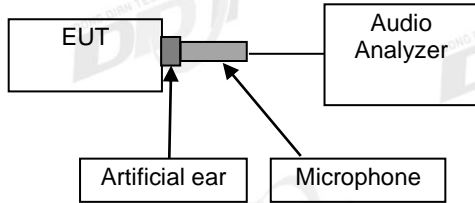

13.5. Test levels and performance criterion

Test Level		Performance Criteria
Frequency and Field Strength	0.15MHz to 10MHz, 3V rms voltage level of the unmodulated signal	A
	10MHz to 30MHz, 3V to 1V rms voltage level of the unmodulated signal	
	30MHz to 80MHz, 1V rms voltage level of the unmodulated signal	
Modulation	AM modulated to a depth of 80% by a sine wave of <input checked="" type="checkbox"/> 1kHz, <input type="checkbox"/> 400Hz (note 1)	
Step Size	1% increments	
Dwell time	1 Sec.	

Note 1: The 1kHz modulation may be replaced by a different audio modulation frequency more appropriate for a given EUT if, for example, 1kHz is not within the operating audio range of the EUT.

Performance criteria A description for devices with the audio output function: The measured acoustic interference ratio and/or the measured electrical interference ratio during the test shall be -20 dB or better.

- The acoustic measurement method was selected according to clause G6.4.1 of EN 55035.
- The electrical measurement method was selected according to clause G6.4.2 of EN 55035.

Performance criteria A for devices with the telephony function.

Frequency range MHz	Acoustic or electrical interference ratio	Equivalent direct measurement		
		dB(SPL)	Digital dBm0	Analogue dBm0
0.15 to 30	-20 dB	55	-50	-50
30 to 80	-10 dB	65	-40	-40

Note: At the step in the frequency range, the lower limit shall be applied.

The interference ratio (electrical or acoustic) shall meet the limits in column 2; or, The acoustic level of the demodulated audio shall be less than the limits in column 3; or The digitally coded level of demodulated audio shall be less than limits in column 4; or, The analogue level of the demodulated audio shall be less than the limits in column 5.

Performance criteria A description for other devices: During and after the test the EUT shall continue to operate as intended without operator intervention. No degradation of performance or loss of function is allowed below a minimum performance level specified by the manufacturer when the EUT is used as intended.

13.6. Test procedure

The EUT are placed on an insulating support 0.1m high above a ground reference plane. CDN (coupling and decoupling device) is placed on the ground plane about 0.3m from EUT. Cables between CDN and EUT are as short as possible, and their height above the ground reference plane shall be between 30 and 50 mm (where possible).

The disturbance signal described below is injected to EUT through CDN.

The EUT operates within its operational mode(s) under intended climatic conditions after power on.

The frequency range is swept from 0.150MHz to 80MHz/230MHz, the interference signal level according to clause 10.5, and with the disturbance signal 80% amplitude modulated with a 1kHz / 400Hz sine wave.

The rate of sweep shall not exceed 1.5×10^{-3} decades/s. Where the frequency is swept incrementally; the step size shall not exceed 1% of the start and thereafter 1% of the preceding frequency value.

Recording the EUT operating situation during compliance testing and decide the EUT immunity criterion.

13.7. Test result

Power supply: AC 230V/50Hz, AC 110V/60Hz						
Modulation Signal: <input checked="" type="checkbox"/> 1kHz <input type="checkbox"/> 400Hz 80% AM <input type="checkbox"/> Other:						
Steps: <input checked="" type="checkbox"/> 1% <input type="checkbox"/> other: Dwell time: <input checked="" type="checkbox"/> 1s <input type="checkbox"/> other:						
Operation mode	Frequency Range	Injected Position	Strength(e.m.f) (unmodulated)	Required	Observation	Result (Pass/Fail)
Mode 1	0.15MHz-10MHz	AC port	3V	A	A	Pass
	10MHz-30MHz	AC port	3V-1V	A	A	Pass
	30MHz-80MHz	AC port	1V	A	A	Pass
Mode1: Audio output: electrical interference ratio= <u>-32.1</u> dB \leq -20dB.						
Mode1: Speaker: Acoustic interference ratio= <u>-33.4</u> dB \leq -20dB.						
Note 1: this row only for the device with audio output function.						
Note 2: this device without the telephony function.						
Observation Description:						
A: Operation as intend, no loss of function during test and after test.						

14. Power-Frequency Magnetic Fields

14.1. General information

Test date	Jun. 04, 2021	Test engineer	Novak	
Climate condition	Ambient temperature	25.4±1℃	Relative humidity	47±1%
	Atmospheric pressure	100.9±0.2kPa		
Test place	Shield Room 3#			

14.2. Test equipment

Equipment	Manufacturer	Model No.	Serial No.	Last Cal.	Cal. Interval
Magnetic Field Coil	TESEQ	INA 702	199	Mar. 04, 2021	1 Year
Magnetic Field Option	TESEQ	MFO 6502	123	Mar. 04, 2021	1 Year

14.3. Test and reference standards

IEC-61000-4-8:2009

BS EN 61000-4-8:2010

14.4. Block diagram of test setup

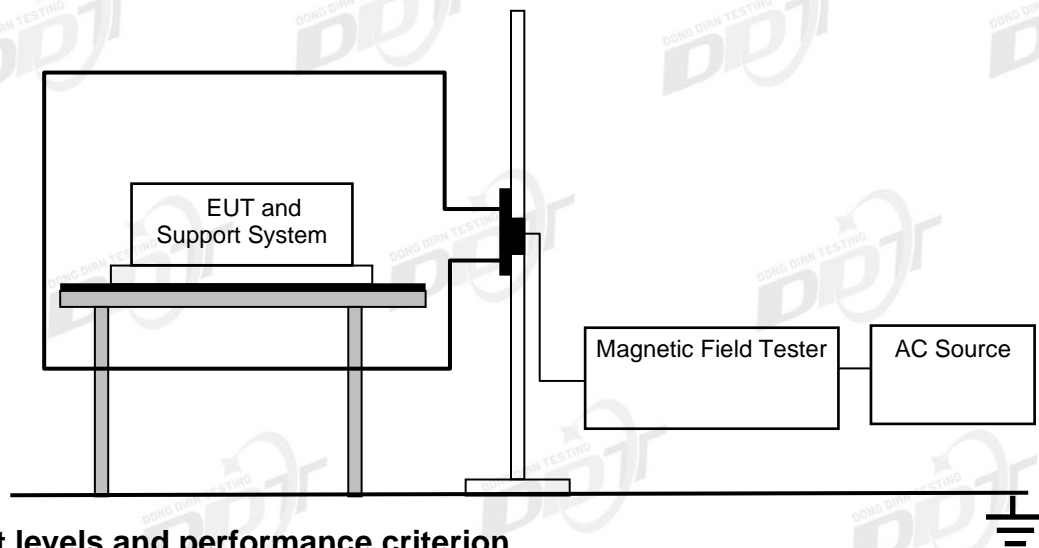

14.5. Test levels and performance criterion

Level	Magnetic Field Strength (A/m)	Performance Criterion
1	1	A

Performance criteria A description: During and after the test the EUT shall continue to operate as intended without operator intervention. No degradation of performance or loss of function is allowed below a minimum performance level specified by the manufacturer when the EUT is used as intended.

14.6. Test procedure

The EUT shall be subjected to the test magnetic field by using the induction coil of standard dimensions (1m*1m) and shown in Section 14.4 Then induction coil shall then be rotated by 90° in order to expose the EUT to the test field with different orientations.

14.7. Test result

Power supply: AC 230V/50Hz, AC 110V/60Hz						
Operation Mode	Test Level	Testing Duration	Coil Orientation	Required	Observation	Result (Pass/Fail)
Mode 2	1A/m	5min/coil	X	A	A	Pass
		5min/coil	Y	A	A	Pass
		5min/coil	Z	A	A	Pass
Observation Description: A: Operation as intend, no loss of function during test and after test.						

15. Voltage Dips and Interruptions

15.1. General information

Test date	Jun. 04, 2021	Test engineer	Novak	
Climate condition	Ambient temperature	25.4±1°C	Relative humidity	47±1%
	Atmospheric pressure	100.9±0.2kPa		
Test place	Shield Room 3#			

15.2. Test equipment

Equipment	Manufacturer	Model No.	Serial No.	Last Cal.	Cal. Interval
VAR	TESEQ	3005-D16	94	Mar. 04, 2021	1 Year

15.3. Test and reference standards

IEC-61000-4-11:2004, IEC-61000-4-11:2004+A1:2017

BS EN 61000-4-11:2004+A1:2017

15.4. Block diagram of test setup

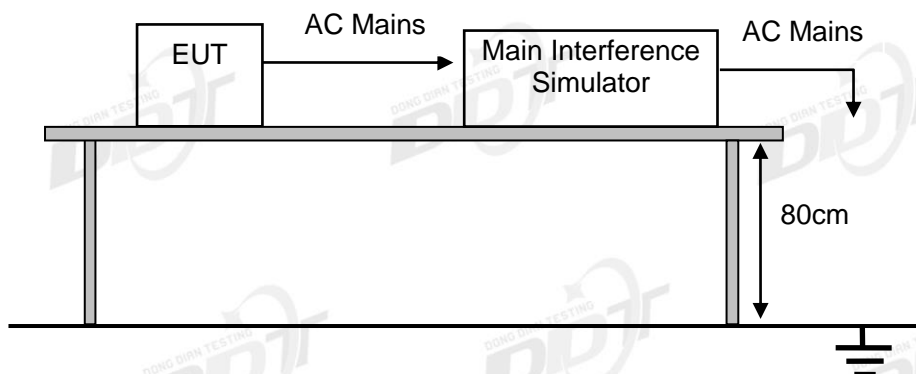

15.5. Test levels and performance criterion

Test Level %UT	Duration (in period)	Performance Criterion
<5	0.5	B
70	25 for 50Hz/30 for 60Hz	C
<5	250 for 50Hz/300 for 60Hz	C

Performance criteria B description: During the test, degradation of performance is allowed. However, no change of operating state or stored data is allowed to persist after the test. After the test, the EUT shall continue to operate as intended without operator intervention. No degradation of performance or loss of function is allowed, after the application of the phenomena below a performance level specified by the manufacturer, when the EUT is used as intended.

Performance criteria C description: During and after testing, a temporary loss of function is allowed, provided the function is self recoverable, or can be restored by the operation of the controls or cycling of the power to the EUT by the user in accordance with the manufacturer's

instructions. Functions, and/or information stored in non-volatile memory, or protected by a battery backup, shall not be lost.

15.6. Test procedure

The EUT and test generator were setup as shown. The interruptions are introduced at selected phase angles with specified duration. Record any degradation of performance.

15.7. Test result

Power Supply: AC 100V/60Hz						
Memo:						
Operation Mode	Voltage Dips & Short Interruptions %Ur	Duration (in period)	Phase Angle	Required	Observation	Result
						(Pass/Fail)
Mode 1	0	0.5P	0°, 180°	B	A	Pass
	70	30P	0°, 180°	C	A	Pass
	0	300P	0°, 180°	C	B	Pass
Observation Description: A: Operation as intend, no loss of function during test and after test. B: Temporary loss of function or degradation of performance which ceases after the disturbance ceases, and from which the equipment under test recovers its normal performance, without operator intervention						

Power Supply: AC 240V/50Hz						
Memo:						
Operation Mode	Voltage Dips & Short Interruptions %Ur	Duration (in period)	Phase Angle	Required	Observation	Result
						(Pass/Fail)
Mode 1	0	0.5P	0°, 180°	B	A	Pass
	70	25P	0°, 180°	C	A	Pass
	0	250P	0°, 180°	C	B	Pass
Observation Description: A: Operation as intend, no loss of function during test and after test. B: Temporary loss of function or degradation of performance which ceases after the disturbance ceases, and from which the equipment under test recovers its normal performance, without operator intervention						

16. Test Setup Photos

16.1 Conducted emission at the mains ports



[Front]



[Rear]

16.2 Radiated emission (Below 1 GHz)



[Front]

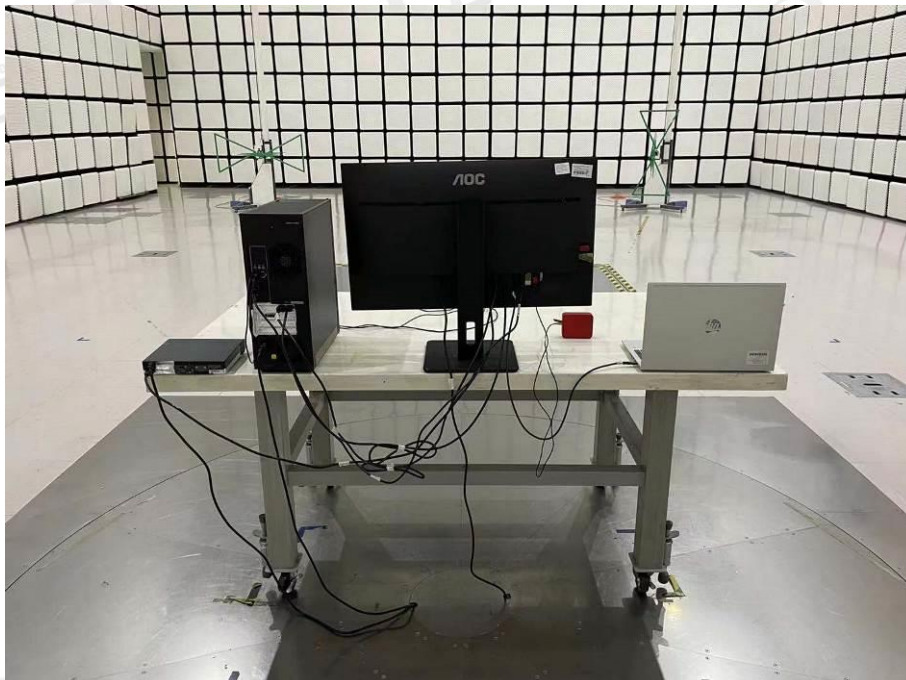

[Rear]

16.3 Radiated emission (Above 1 GHz)

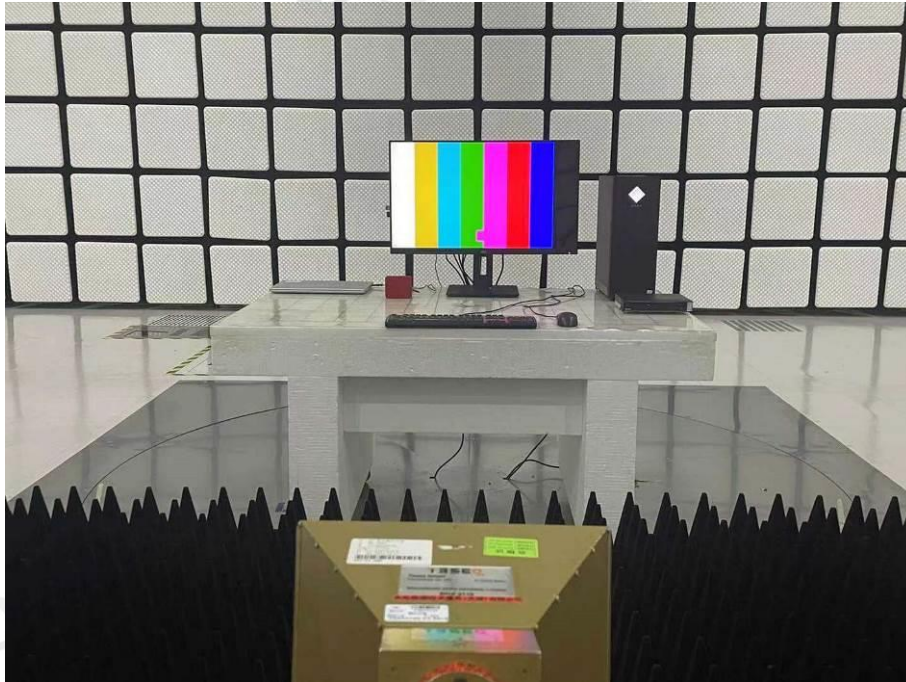

[Front]



[Rear]

16.4 Harmonic current



16.5 Voltage fluctuation & Flicker



16.6 Electrostatic discharge test

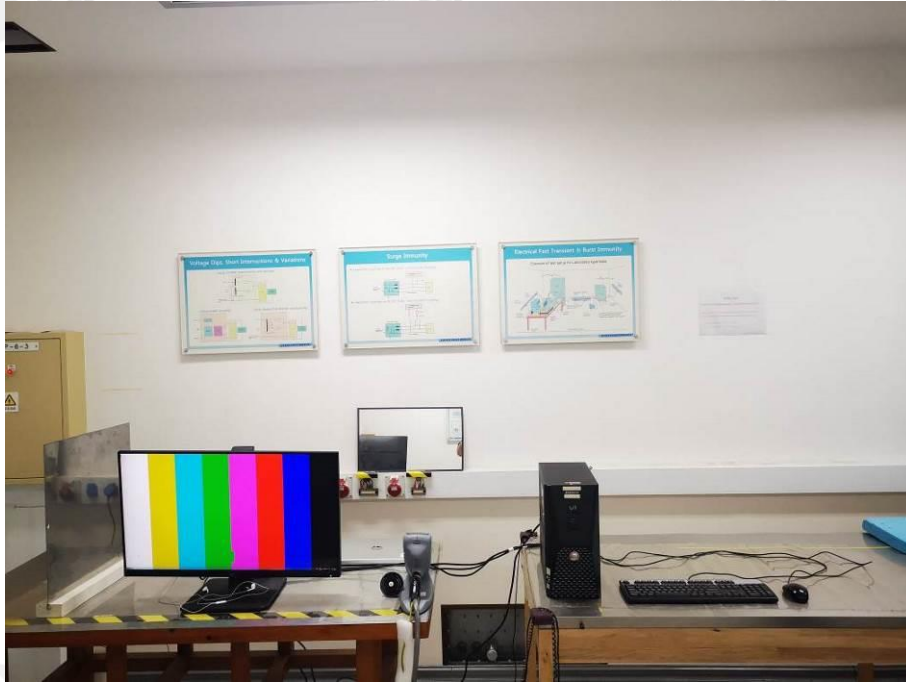

16.7 Continuous Radio Frequency Disturbances

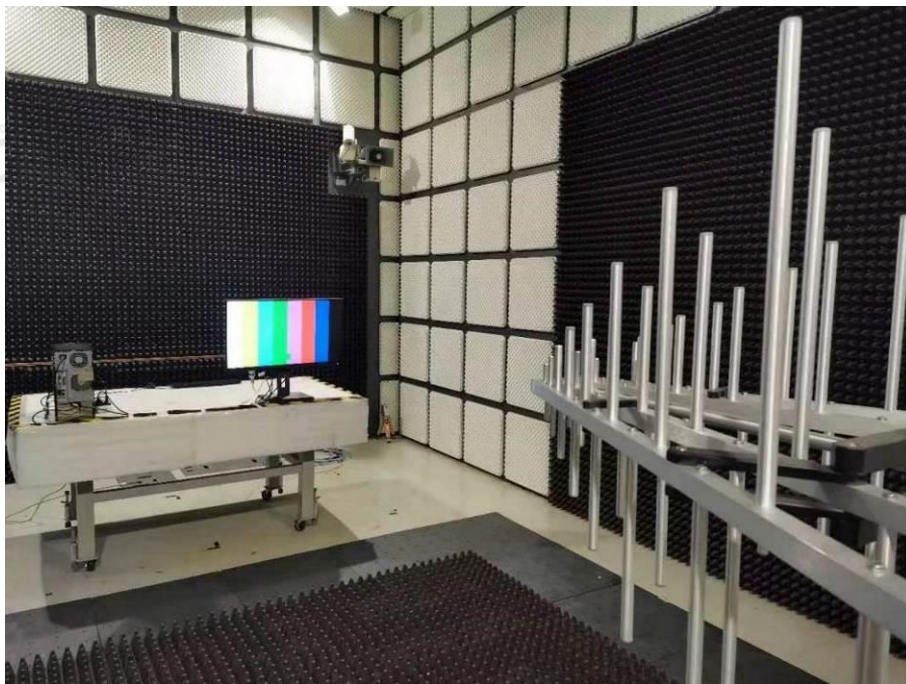

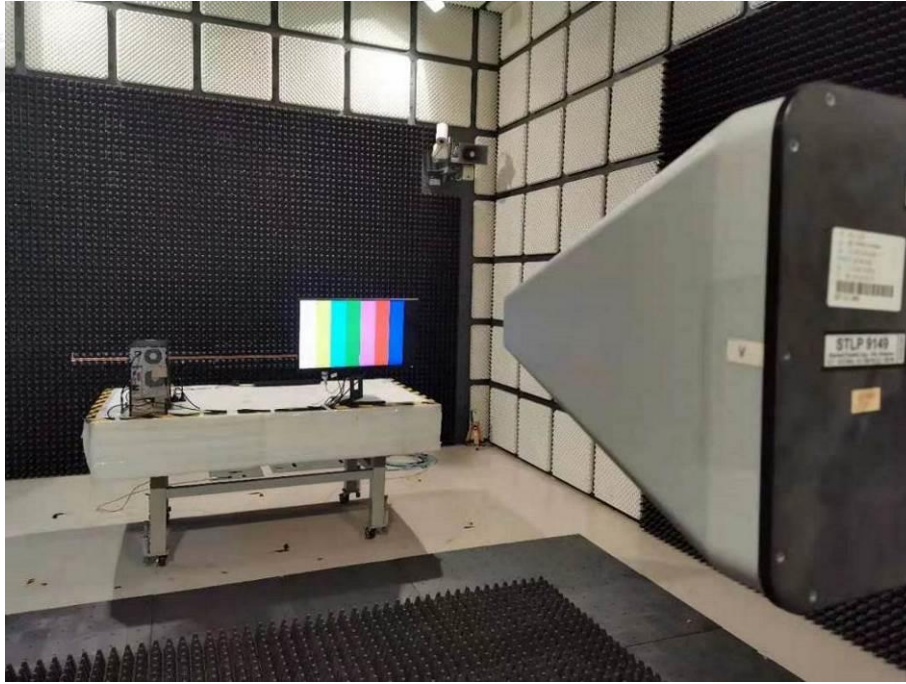

16.8 Electrical fast transients(EFT)



16.9 Surge



16.10 Continuous conducted disturbances

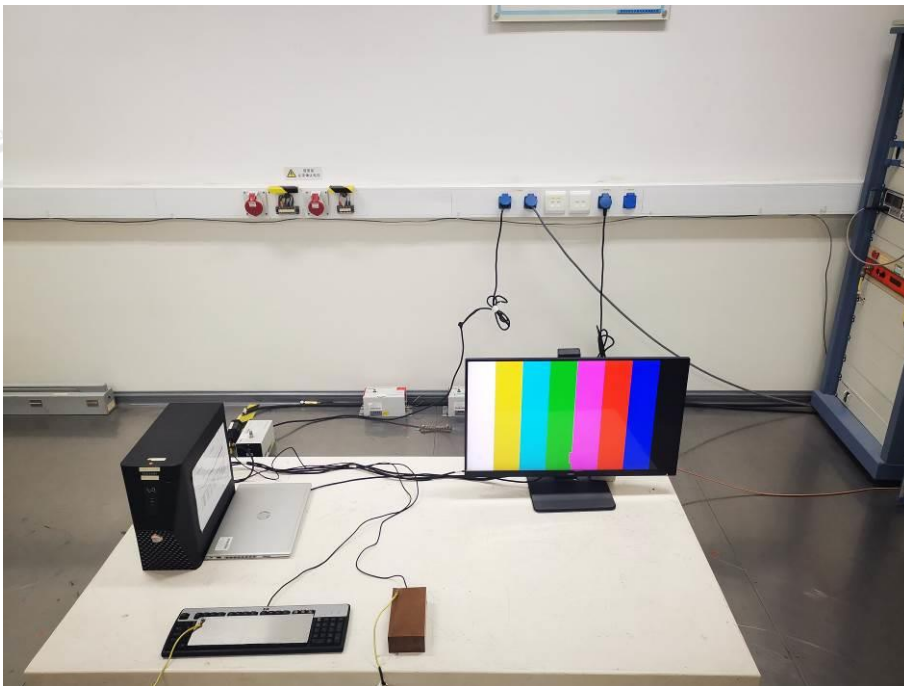

16.11 Power-frequency magnetic fields test



16.12 Voltage dips and interruptions

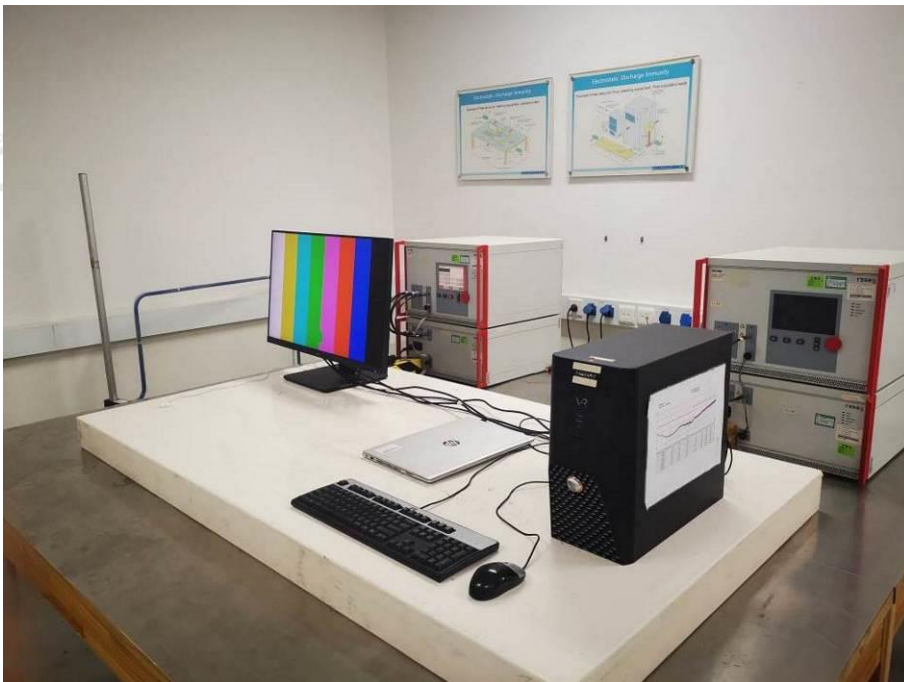

END OF REPORT