

CE EMC Test Report

Project No. : 2101C206
Equipment : LCD Monitor
Brand Name : N/A
Test Model : **254*****(*=A-Z,a-z,0-9,/, +,-,\ or blank)
Series Model : N/A
Applicant : TPV Electronics (Fujian) Co., Ltd.
Address : Rongqiao Economic and Technological Development Zone, Fuqing City,
Fujian Province, P.R. China
Date of Receipt : Jan. 22, 2021
Date of Test : Jan. 26, 2021 ~ Feb. 09, 2021
Issued Date : Feb. 22, 2021
Report Version : R00
Test Sample : Engineering Sample No.: DG2021012563
Standard(s) : EN 55032:2012+AC:2013
EN 55032:2015
EN 55032:2015+AC:2016
EN 55035:2017
BS EN 55032:2015+AC:2016
BS EN 55035:2017
IEC 61000-3-2:2014 / EN 61000-3-2:2014 / BS EN 61000-3-2:2014
IEC 61000-3-3:2013+A1:2017 / EN 61000-3-3:2013+A1:2019 /
/ BS EN 61000-3-3:2013+A1:2019
AS/NZS CISPR 32:2015 / CISPR 32:2015+C1:2016
AS/NZS CISPR 32:2013 / CISPR 32:2012

The above equipment has been tested and found compliance with the requirement of the relative standards by BTL Inc.

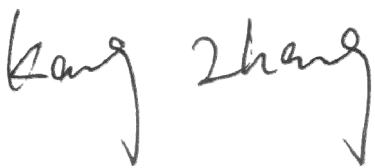

Prepared by : Kang Zhang

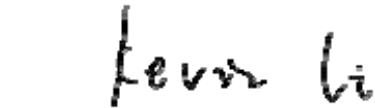

Approved by : Kevin Li



Certificate #5123.02

Add: No.3, Jinshagang 1st Road, Shixia, Dalang Town, Dongguan, Guangdong, China.

Tel: +86-769-8318-3000

Web: www.newbtl.com

Declaration

BTL represents to the client that testing is done in accordance with standard procedures as applicable and that test instruments used has been calibrated with standards traceable to international standard(s) and/or national standard(s).

BTL's reports apply only to the specific samples tested under conditions. It is manufacture's responsibility to ensure that additional production units of this model are manufactured with the identical electrical and mechanical components. **BTL** shall have no liability for any declarations, inferences or generalizations drawn by the client or others from **BTL** issued reports.

The report must not be used by the client to claim product certification, approval, or endorsement by NVLAP, NIST, A2LA, or any agency of the U.S. Government.

This report is the confidential property of the client. As a mutual protection to the clients, the public and ourselves, the test report shall not be reproduced, except in full, without our written approval.

BTL's laboratory quality assurance procedures are in compliance with the **ISO/IEC 17025** requirements, and accredited by the conformity assessment authorities listed in this test report.

BTL is not responsible for the sampling stage, so the results only apply to the sample as received.

The information, data and test plan are provided by manufacturer which may affect the validity of results, so it is manufacturer's responsibility to ensure that the apparatus meets the essential requirements of applied standards and in all the possible configurations as representative of its intended use.

Limitation

For the use of the authority's logo is limited unless the Test Standard(s)/Scope(s)/Item(s) mentioned in this test report is (are) included in the conformity assessment authorities acceptance respective.

Please note that the measurement uncertainty is provided for informational purpose only and are not use in determining the Pass/Fail results.

Table of Contents	Page
REPORT ISSUED HISTORY	7
1 . SUMMARY OF TEST RESULTS	8
1.1 TEST FACILITY	10
1.2 MEASUREMENT UNCERTAINTY	10
1.3 TEST ENVIRONMENT CONDITIONS	12
2 . GENERAL INFORMATION	13
2.1 GENERAL DESCRIPTION OF EUT	13
2.2 DESCRIPTION OF TEST MODES	14
2.3 EUT OPERATING CONDITIONS	16
2.4 BLOCK DIAGRAM SHOWING THE CONFIGURATION OF SYSTEM TESTED	16
2.5 DESCRIPTION OF SUPPORT UNITS	17
3 . EMC EMISSION TEST- EN55032:2012+AC:2013 & 2015	18
3.1 RADIATED EMISSION UP TO 1 GHZ	18
3.1.1 LIMITS	18
3.1.2 MEASUREMENT INSTRUMENTS LIST	18
3.1.3 TEST PROCEDURE	19
3.1.4 DEVIATION FROM TEST STANDARD	19
3.1.5 TEST SETUP	19
3.1.6 MEASUREMENT DISTANCE	20
3.1.7 TEST RESULTS (UP TO 1 GHZ)	21
3.2 RADIATED EMISSION ABOVE 1 GHZ	31
3.2.1 LIMITS	31
3.2.2 MEASUREMENT INSTRUMENTS LIST	31
3.2.3 TEST PROCEDURE	32
3.2.4 DEVIATION FROM TEST STANDARD	32
3.2.5 TEST SETUP	32
3.2.6 MEASUREMENT DISTANCE	33
3.2.7 TEST RESULTS (ABOVE 1 GHZ)	34
3.3 CONDUCTED EMISSION MEASUREMENT AT AC MAINS POWER PORTS	44
3.3.1 LIMITS	44
3.3.2 MEASUREMENT INSTRUMENTS LIST	44
3.3.3 TEST PROCEDURE	44
3.3.4 DEVIATION FROM TEST STANDARD	44
3.3.5 TEST SETUP	45
3.3.6 TEST RESULTS	46
4 . EMC EMISSION TEST- EN 55032:2015+AC:2016	54
4.1 RADIATED EMISSIONS UP TO 1 GHZ	54

Table of Contents	Page
4.1.1 LIMITS	54
4.1.2 MEASUREMENT INSTRUMENTS LIST	54
4.1.3 TEST PROCEDURE	55
4.1.4 DEVIATION FROM TEST STANDARD	55
4.1.5 TEST SETUP	55
4.1.6 MEASUREMENT DISTANCE	56
4.1.7 TEST RESULTS (UP TO 1 GHZ)	57
4.2 RADIATED EMISSIONS ABOVE 1 GHZ	59
4.2.1 LIMITS	59
4.2.1 MEASUREMENT INSTRUMENTS LIST	59
4.2.1.1 TEST PROCEDURE	60
4.2.1.2 DEVIATION FROM TEST STANDARD	60
4.2.1.3 TEST SETUP	60
4.2.1.4 MEASUREMENT DISTANCE	61
4.2.1.5 TEST RESULTS (ABOVE 1 GHZ)	62
4.3 CONDUCTED EMISSION MEASUREMENT AT AC MAINS POWER PORTS	64
4.3.1 LIMITS	64
4.3.2 MEASUREMENT INSTRUMENTS LIST	64
4.3.3 TEST PROCEDURE	64
4.3.4 TEST SETUP	65
4.3.5 TEST RESULTS	66
5 . HARMONIC AND FLICKER TEST	68
5.1 HARMONIC CURRENT EMISSIONS	68
5.1.1 LIMITS	68
5.1.2 MEASUREMENT INSTRUMENTS LIST	68
5.1.3 TEST PROCEDURE	68
5.1.4 DEVIATION FROM TEST STANDARD	68
5.1.5 TEST SETUP	68
5.1.6 TEST RESULTS	69
5.2 VOLTAGE CHANGES, VOLTAGE FLUCTUATIONS AND FLICKER TEST	72
5.2.1 LIMITS	72
5.2.2 MEASUREMENT INSTRUMENTS LIST	72
5.2.3 TEST PROCEDURE	72
5.2.4 DEVIATION FROM TEST STANDARD	72
5.2.5 TEST SETUP	73
5.2.6 TEST RESULTS	74
6 . EMC IMMUNITY TEST	75
6.1 STANDARD COMPLIANCE/SEVERITY LEVEL/CRITERIA	75
6.2 GENERAL PERFORMANCE CRITERIA	78
6.3 ANNEX D (NORMATIVE) - DISPLAY AND DISPLAY OUTPUT FUNCTION	79
6.3.1 PERFORMANCE CRITERIA	79

Table of Contents	Page
6.4 ANNEX G (NORMATIVE) - AUDIO OUTPUT FUNCTION	80
6.4.1 PERFORMANCE CRITERIA	80
6.5 ELECTROSTATIC DISCHARGE IMMUNITY TEST (ESD)	81
6.5.1 TEST SPECIFICATION	81
6.5.2 MEASUREMENT INSTRUMENTS	81
6.5.3 TEST PROCEDURE	81
6.5.4 DEVIATION FROM TEST STANDARD	82
6.5.5 TEST SETUP	82
6.5.6 TEST RESULTS	83
6.6 RADIATED, RADIO-FREQUENCY, ELECTROMAGNETIC FIELD IMMUNITY TEST (RS)	87
6.6.1 TEST SPECIFICATION	87
6.6.2 MEASUREMENT INSTRUMENTS	87
6.6.3 TEST PROCEDURE	87
6.6.4 DEVIATION FROM TEST STANDARD	88
6.6.5 TEST SETUP	88
6.6.6 TEST RESULTS	90
6.7 ELECTRICAL FAST TRANSIENT/BURST IMMUNITY TEST (EFT/BURST)	95
6.7.1 TEST SPECIFICATION	95
6.7.2 MEASUREMENT INSTRUMENTS	95
6.7.3 TEST PROCEDURE	95
6.7.4 DEVIATION FROM TEST STANDARD	95
6.7.5 TEST SETUP	96
6.7.6 TEST RESULTS	97
6.8 SURGE IMMUNITY TEST	98
6.8.1 TEST SPECIFICATION	98
6.8.2 MEASUREMENT INSTRUMENTS	98
6.8.3 TEST PROCEDURE	98
6.8.4 DEVIATION FROM TEST STANDARD	99
6.8.5 TEST SETUP	99
6.8.6 TEST RESULTS	100
6.9 IMMUNITY TO CONDUCTED DISTURBANCES, INDUCED BY RADIO-FREQUENCY FIELDS TEST (CS)	101
6.9.1 TEST SPECIFICATION	101
6.9.2 MEASUREMENT INSTRUMENTS	101
6.9.3 TEST PROCEDURE	101
6.9.4 DEVIATION FROM TEST STANDARD	102
6.9.5 TEST SETUP	102
6.9.6 TEST RESULTS	104
6.10 POWER FREQUENCY MAGNETIC FIELD IMMUNITY TEST (PFMF)	107
6.10.1 TEST SPECIFICATION	107
6.10.2 MEASUREMENT INSTRUMENTS	107
6.10.3 TEST PROCEDURE	107

Table of Contents	Page
6.10.4 DEVIATION FROM TEST STANDARD	107
6.10.5 TEST SETUP	108
6.10.6 TEST RESULTS	109
6.11 VOLTAGE DIPS, SHORT INTERRUPTIONS AND VOLTAGE VARIATIONS IMMUNITY	
TEST (DIPS)	110
6.11.1 TEST SPECIFICATION	110
6.11.2 MEASUREMENT INSTRUMENTS	110
6.11.3 TEST PROCEDURE	110
6.11.4 DEVIATION FROM TEST STANDARD	110
6.11.5 TEST SETUP	110
6.11.6 TEST RESULTS	111
7 . EUT TEST PHOTO	112

REPORT ISSUED HISTORY

Report Version	Description	Issued Date
R00	Original Issue.	Feb. 22, 2021

1. SUMMARY OF TEST RESULTS

Test procedures according to the technical standards:

Emission			
Standard(s)	Test Item	Result	
EN 55032:2012+AC:2013 EN 55032:2015 EN 55032:2015+AC:2016 BS EN 55032:2015+AC:2016 AS/NZS CISPR 32:2015 CISPR 32:2015+C1:2016 AS/NZS CISPR 32:2013 CISPR 32:2012	Radiated emissions up to 1 GHz	PASS	
	Radiated emissions above 1 GHz	PASS	
	Radiated emissions from FM receivers	N/A	
	Conducted emissions AC mains power port	PASS	
	Asymmetric mode conducted emissions	AAN	N/A
		Current Probe	N/A
		CP+CVP	N/A
Conducted differential voltage emissions	N/A		

Standard(s)	Test Item	Result
IEC 61000-3-2:2014 EN 61000-3-2:2014 BS EN 61000-3-2:2014	Harmonic current	PASS
IEC 61000-3-3:2013+A1:2017 EN 61000-3-3:2013+A1:2019 BS EN 61000-3-3:2013+A1:2019	Voltage fluctuations (Flicker)	PASS

Immunity			
Standard(s)	Ref Standard(s)	Test Item	Result
EN 55035: 2017 BS EN 55035:2017	IEC 61000-4-2:2008 EN 61000-4-2:2009 BS EN 61000-4-2:2009	ESD	PASS
	IEC 61000-4-3:2006+A1:2007+A2:2010 EN 61000-4-3:2006+A1:2008+A2:2010 BS EN 61000-4-3:2006+A1:2008+A2:2010	RS	PASS
	IEC 61000-4-4:2012 EN 61000-4-4:2012 BS EN 61000-4-4:2012	EFT	PASS
	IEC 61000-4-5:2014+A1:2017 EN 61000-4-5:2014+A1:2017 BS EN 61000-4-5:2014+A1:2017	Surge	PASS
	IEC 61000-4-6:2013 EN 61000-4-6:2014+AC:2015 BS EN 61000-4-6:2014+AC:2015	CS	PASS
	IEC 61000-4-8:2009 EN 61000-4-8:2010 BS EN 61000-4-8:2010	PFMF	PASS
	IEC 61000-4-11:2004+A1:2017 EN 61000-4-11:2004+A1:2017 BS EN 61000-4-11:2004+A1:2017	Dips	PASS

EN 55035: 2017 BS EN 55035:2017	4.2.7	Broadband impulse noise disturbances, repet itive	N/A
	4.2.7	Broadband impulse noise disturbances, isolat ed	N/A

NOTE:

(1) "N/A" denotes test is not applicable to this device.

1.1 TEST FACILITY

The test facilities used to collect the test data in this report is at the location of No.3, Jinshagang 1st Road, Shixia, Dalang Town, Dongguan, Guangdong, China.

1.2 MEASUREMENT UNCERTAINTY

Where relevant, the following measurement uncertainty levels have been estimated for tests performed on the EUT as specified in CISPR 16-4-2, The BTL measurement uncertainty is less than the CISPR 16-4-2 U_{cispr} requirement.

The reported uncertainty of measurement $y \pm U$, where expanded uncertainty U is based on a standard uncertainty multiplied by a coverage factor of $k=2$, providing a level of confidence of approximately **95%**.

A. Radiated emissions up to 1 GHz measurement:

Test Site	Method	Measurement Frequency Range	Ant. H / V	U,(dB)
DG-CB08 (10m)	CISPR	30MHz ~ 200MHz	V	4.44
		30MHz ~ 200MHz	H	3.44
		200MHz ~ 1,000MHz	V	4.28
		200MHz ~ 1,000MHz	H	3.52

B. Radiated emissions above 1 GHz measurement:

Test Site	Method	Measurement Frequency Range	U,(dB)
DG-CB08 (3m)	CISPR	1GHz ~ 6GHz	4.36

C. Conducted emissions AC mains power port measurement:

Test Site	Method	Measurement Frequency Range	U,(dB)
DG-C01	CISPR	150kHz ~ 30MHz	3.18

D. Harmonic/ Flicker Measurement:

Test Site	Method	Item	U (%)
DG-C01	EN 61000-3-2	Current	0.593
	EN 61000-3-3	Voltage	0.595

E. Immunity Measurement:

Test Site	Method	Item	U
DG-SR02	IEC 61000-4-2	Rise time tr	6.80%
		Peak current Ip	6.30%
		Current at 30 ns	6.50%
		Current at 60 ns	6.90%
DG-CB05	IEC 61000-4-3 (80MHz~6GHz)	Electromagnetic field immunity test	2.38dB
		On-ear acoustic & Acoustic measurements on loudspeakers	2.40dB
		Electrical measurements	2.40dB
DG-SR05	IEC 61000-4-4	Peak voltage (V _P)	3.7%
		Rise time (tr)	4.4%
		Pulse width(tw)	4.1%
		Pulse Freq.(kHz)	0.8%
		Burst Duration(ms)	1.4%
		Burst Period(ms)	1.4%
DG-SR05	IEC 61000-4-5	Open-Circuit Output Voltage (1.2/50us)	3.8%
		Open circuit front time (1.2/50us)	6.3%
		Open circuit time of half value (1.2/50us)	4.6%
DG-CB06	IEC 61000-4-6 (150kHz-80MHz)	CDN	1.32dB
		EM clamp	3.16dB
		On-ear acoustic & Acoustic measurements on loudspeakers	1.36dB
		Electrical measurements	1.34dB
DG-SR05	IEC 61000-4-8	Magnetic Field Strength	2.38%
DG-SR05	IEC 61000-4-11	DIP Amplitude	0.5%
		DIP Time Event	3%

Note: Unless specifically mentioned, the uncertainty of measurement has not been taken into account to declare the compliance or non-compliance to the specification.

1.3 TEST ENVIRONMENT CONDITIONS

Test Item	Temperature	Humidity	Tested By
Radiated emissions up to 1 GHz	25°C	60%	Hawe Zhang
Radiated emissions above 1 GHz	25°C	60%	Hawe Zhang
Conducted emissions AC mains power port	25°C	53%	Gerry Zhao
Harmonic current	25°C	55%	Gerry Zhao
Voltage fluctuations (Flicker)	25°C	55%	Gerry Zhao

Test Item	Temperature	Humidity	Pressure	Tested By
ESD	22°C	45%	1010hPa	Rich Ye
RS	22°C	50%	/	Hunter Xu
EFT	22°C	50%	/	Celina Lai
Surge	22°C	50%	/	Celina Lai
CS	22°C	50%	/	Daniel Li
PFMF	22°C	50%	/	Daniel Li
Dips	22°C	50%	/	Daniel Li

2. GENERAL INFORMATION

2.1 GENERAL DESCRIPTION OF EUT

Equipment	LCD Monitor
Brand Name	N/A
Test Model	**254*****(*=A-Z,a-z,0-9,/, +,-,\ or blank)
Series Model	N/A
Model Difference(s)	The market distribution is different only.
Power Source	DC Voltage supplied from AC adapter. Model: ADPC20120
Power Rating	I/P:100-240V~, 1.5A 50-60Hz O/P:20.0V --- 6.0A 120.0W
Connecting I/O Port(s)	1* DC port 2* HDMI port 1* DP port 5* USB port 1* Micro USB port 2* AUDIO port
Classification Of EUT	Class B
Highest Internal Frequency(Fx)	571MHz

Cable Type	Shielded Type	Ferrite Core	Length(m)	Note
AC Power Cord	Non-shielded	NO	1.8/1.5/1.2	1.8m is worst case Detachable
HDMI	Shielded	NO	1.8/1.5/1.2	-
DP	Shielded	NO	1.8/1.5/1.2	-
USB	Shielded	NO	1.8/1.5/1.2	-

Note:

- For a more detailed features description, please refer to the manufacturer's specifications or the user's manual.
- Power cable 1.8m, 1.5m, 1.2m length, worst case is Power cable 1.8m with HDMI + DP + USB length testing and recording in test report.

2.2 DESCRIPTION OF TEST MODES

To investigate the maximum EMI emission characteristics generates from EUT, the test system was pre-scanning tested base on the consideration of following EUT operation mode or test configuration mode which possible have effect on EMI emission level. Each of these EUT operation mode(s) or test configuration mode(s) mentioned above was evaluated respectively.

Pretest Mode	Description
Mode 1	HDMI1 1920*1080/240Hz 1.8m H
Mode 2	HDMI2 1920*1080/240Hz 1.8m H
Mode 3	DP 1920*1080/360Hz 1.8m H
Mode 4	HDMI1 1080P 1.8m H
Mode 5	HDMI2 1080P 1.8m H
Mode 6	HDMI1 1280*1024/75Hz 1.8m H
Mode 7	HDMI1 640*480/75Hz 1.8m H
Mode 8	HDMI1 1920*1080/240Hz 1.5m H
Mode 9	HDMI1 1920*1080/240Hz 1.2m H
Mode 10	HDMI1 1920*1080/240Hz 1.8m V
Mode 11	HDMI1 1920*1080/240Hz+Without Earphone 1.8m H

Radiated emissions up to 1 GHz test	
Final Test Mode	Description
Mode 1	HDMI1 1920*1080/240Hz 1.8m H
Mode 3	DP 1920*1080/360Hz 1.8m H
Mode 4	HDMI1 1080P 1.8m H
Mode 11	HDMI1 1920*1080/240Hz+Without Earphone 1.8m H

Radiated emissions Above 1 GHz test	
Final Test Mode	Description
Mode 1	HDMI1 1920*1080/240Hz 1.8m H
Mode 3	DP 1920*1080/360Hz 1.8m H
Mode 4	HDMI1 1080P 1.8m H
Mode 11	HDMI1 1920*1080/240Hz+Without Earphone 1.8m H

Conducted emissions AC mains power port test	
Final Test Mode	Description
Mode 1	HDMI1 1920*1080/240Hz 1.8m H
Mode 3	DP 1920*1080/360Hz 1.8m H
Mode 4	HDMI1 1080P 1.8m H

Harmonic current & Voltage fluctuations (Flicker) Test	
Final Test Mode	Description
Mode 1	HDMI1 1920*1080/240Hz 1.8m H

Immunity Test	
Final Test Mode	Description
Mode 1	HDMI1 1920*1080/240Hz 1.8m H
Mode 2	HDMI2 1920*1080/240Hz 1.8m H
Mode 3	DP 1920*1080/360Hz 1.8m H
Mode 4	HDMI1 1080P 1.8m H
Mode 5	HDMI2 1080P 1.8m H
Mode 8	HDMI1 1920*1080/240Hz 1.5m H
Mode 9	HDMI1 1920*1080/240Hz 1.2m H

Evaluation description:

1. The maximum resolution is evaluated Mode 1-5. The worst case is Mode 1 and evaluated the middle and low resolution Mode 6 and Mode 7.
2. According to the client's requirement, choose Mode 1, Mode 3, Mode 4 and recorded in test report.
3. RS Acoudtic: The Front, Rear, Left and Right were evaluated. The worst placement direction is Front and recorded in this report.

2.3 EUT OPERATING CONDITIONS

The EUT exercise program used during radiated and/or conducted emission measurement was designed to exercise the various system components in a manner similar to a typical use. The standard test signals and output signal as following:

1. EUT connected to Adapter via DC cable.
2. EUT connected to PC via HDMI&DP&USB cable.
3. EUT connected to Headsets via AUDIO cable.
4. Mouse and Keyboard connected to PC via USB cable.
5. EUT connected to USB3.0 Hard Disks via USB cable.
6. EUT connected to Controller via USB cable.

2.4 BLOCK DIAGRAM SHOWING THE CONFIGURATION OF SYSTEM TESTED

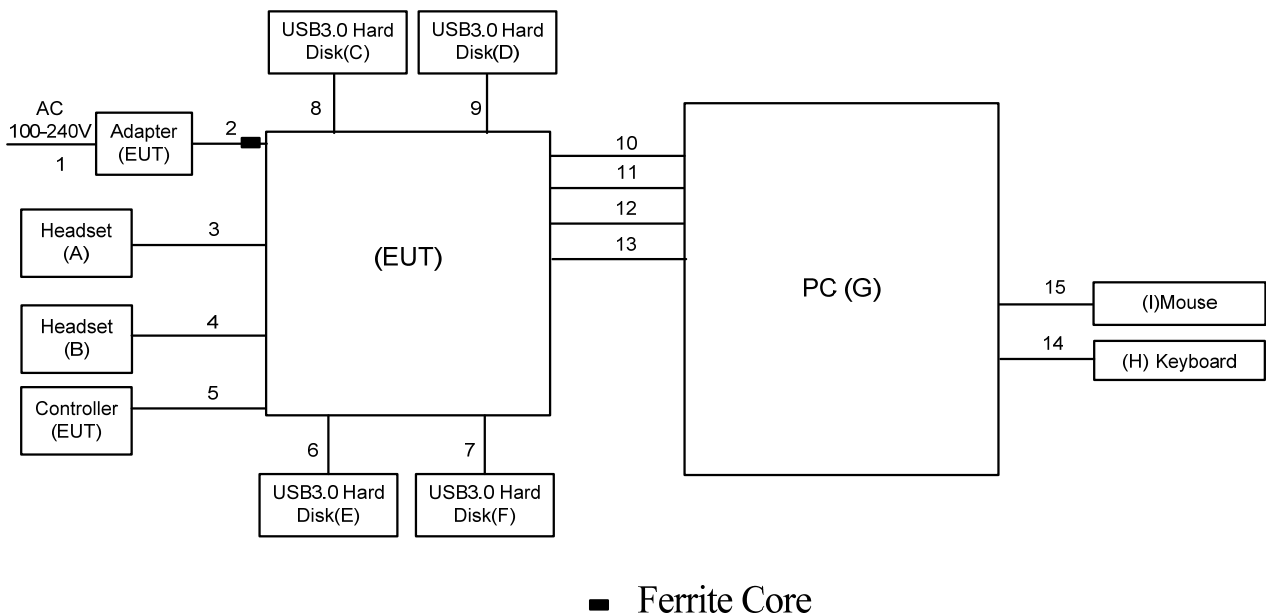

2.5 DESCRIPTION OF SUPPORT UNITS

The EUT has been tested as an independent unit together with other necessary accessories or support units. The following support units or accessories were used to form a representative test configuration during the tests.

Item	Equipment	Mfr/Brand	Model/Type No.	Series No.
A	Headset	PHILIPS	SHMI500	N/A
B	Headset	PHILIPS	SHMI500	N/A
C	USB3.0 Hard Disk	LACIE	Lacie S.A	NL34BFER
D	USB3.0 Hard Disk	LACIE	Lacie S.A	NL34BJSM
E	USB3.0 Hard Disk	LACIE	Lacie S.A	NL33PVLS
F	USB3.0 Hard Disk	LACIE	Lacie S.A	NL34BJRF
G	PC	DELL	Vostro 470	24454162837
H	Keyboard	DELL	KB212-B	CN0HTXH97158125004DXA01
I	Mouse	DELL	MS111-P	CN011D3V71581279OLOT

Item	Cable Type	Shielded Type	Ferrite Core	Length
1	AC Cable	NO	NO	1.8/1.5/1.2m
2	DC Cable	NO	YES	1.5m
3	AUDIO Cable	NO	NO	1.2m
4	AUDIO Cable	NO	NO	1.2m
5	USB Cable	NO	NO	1.2m
6	USB Cable	YES	NO	1m
7	USB Cable	YES	NO	1m
8	USB Cable	YES	NO	1m
9	USB Cable	YES	NO	1m
10	HDMI Cable	YES	NO	1.8/1.5/1.2m
11	HDMI Cable	YES	NO	1.8/1.5/1.2m
12	DP Cable	YES	NO	1.8/1.5/1.2m
13	USB Cable	YES	NO	1.8/1.5/1.2m
14	USB Cable	YES	NO	1.8m
15	USB Cable	YES	NO	1.8/m

3. EMC EMISSION TEST- EN55032:2012+AC:2013 & 2015

3.1 RADIATED EMISSION UP TO 1 GHZ

3.1.1 LIMITS

Class B equipment up to 1000MHz

Frequency MHz	Measurement		Class B limit dB(uV/m)
	Distance m	Detector type/bandwidth	SAC
30-230	10	Quasi peak / 120 kHz	30
230-1000			37

Notes:

- (1) The limit for radiated test was performed according to as following: EN 55032
- (2) The tighter limit applies at the band edges.
- (3) Emission level (dBuV/m)=20log Emission level (uV/m).
- (4) The test result calculated as following:
 Measurement Value = Reading Level + Correct Factor
 Correct Factor = Antenna Factor + Cable Loss - Amplifier Gain(if use)
 Margin Level = Measurement Value - Limit Value

3.1.2 MEASUREMENT INSTRUMENTS LIST

Item	Kind of Equipment	Manufacturer	Type No.	Series Model	Calibrated until
1	Receiver	Keysight	N9038A	MY54450004	Jul. 25, 2021
2	MXE EMI Receiver	Agilent	N9038A	MY53220133	Feb. 28, 2021
3	Pre-Amplifier	EMC INSTRUMENT	EMC 9135	980284	Mar. 01, 2021
4	Pre-Amplifier	EMC INSTRUMENT	EMC 9135	980283	Mar. 01, 2021
5	Trilog-Broadband Antenna	Schwarzbeck	VULB9168	946	Oct. 16, 2021
6	Trilog-Broadband Antenna	Schwarzbeck	VULB9168	947	Nov. 09, 2021
7	Cable	emci	LMR-400 (5m+11m+8m)	N/A	Oct. 19, 2021
8	Cable	emci	LMR-400 (5m+8m+8m)	N/A	Oct. 20, 2021
9	Measurement Software	Farad	EZ-EMC Ver.BTL-2ANT-1	N/A	N/A
10	Multi-Device Controller	ETS-Lindgren	2090	N/A	N/A
11	Attenuator	EMCI	EMCI-N-6-06	N0670	Nov. 09, 2021
12	Attenuator	EMCI	EMCI-N-6-06	N0671	Oct. 16, 2021

Remark: "N/A" denotes no model no., no serial no. or no calibration specified.

All calibration period of equipment list is one year.

3.1.3 TEST PROCEDURE

- a. The measuring distance of 10 m shall be used for measurements. The EUT was placed on the top of a rotating table 0.8 meter above the ground at a 10 meter semi-anechoic chamber. The table was rotated 360 degrees to determine the position of the highest radiation.(below 1GHz).
- c. The height of the equipment or of the substitution antenna shall be 0.8 m, the height of the test antenna shall vary between 1 m to 4 m. Both horizontal and vertical polarizations of the antenna are set to make the measurement.
- d. The initial step in collecting radiated emission data is a receiver peak detector mode pre-scanning the measurement frequency range. Significant peaks are then marked and then Quasi Peak detector mode re-measured.
- e. All readings are Peak unless otherwise stated QP in column of Note. Peak denotes that the Peak reading compliance with the QP Limits and then QP Mode measurement didn't perform.
(below 1GHz)
- g. For the actual test configuration, please refer to the related Item - Block Diagram of system tested.

3.1.4 DEVIATION FROM TEST STANDARD

No deviation

3.1.5 TEST SETUP

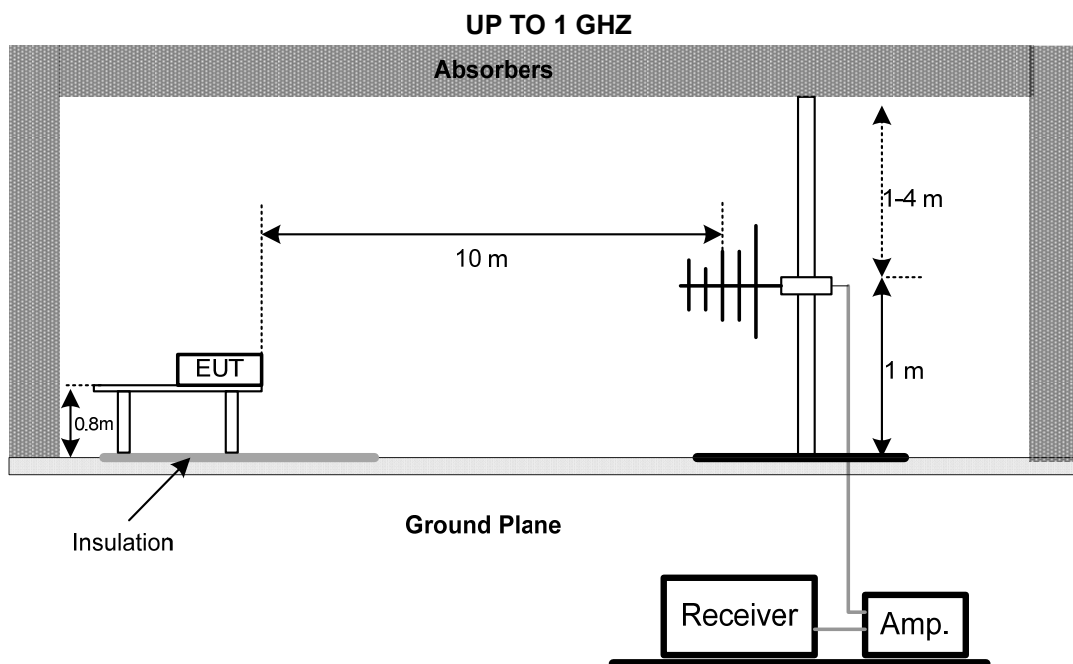

Note: The antenna can be moved between 1 to 4 meters above the ground.

3.1.6 MEASUREMENT DISTANCE

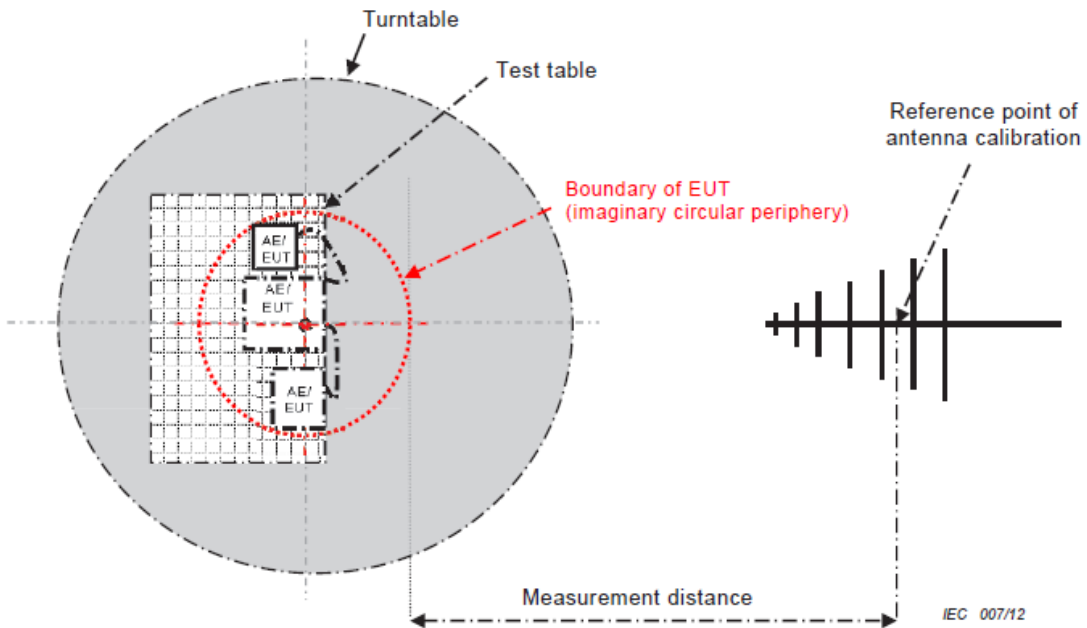

- 34 -

CISPR 32 © IEC:2012

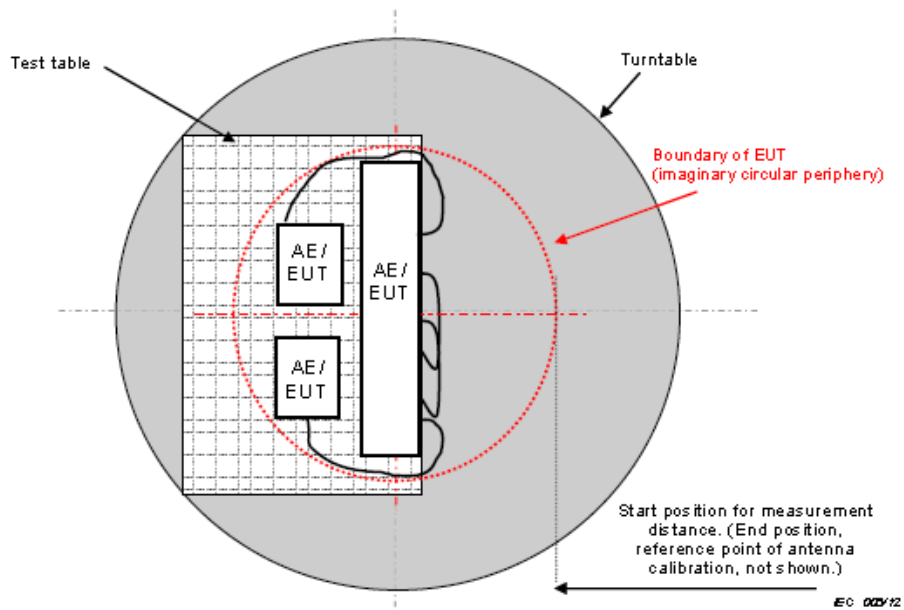
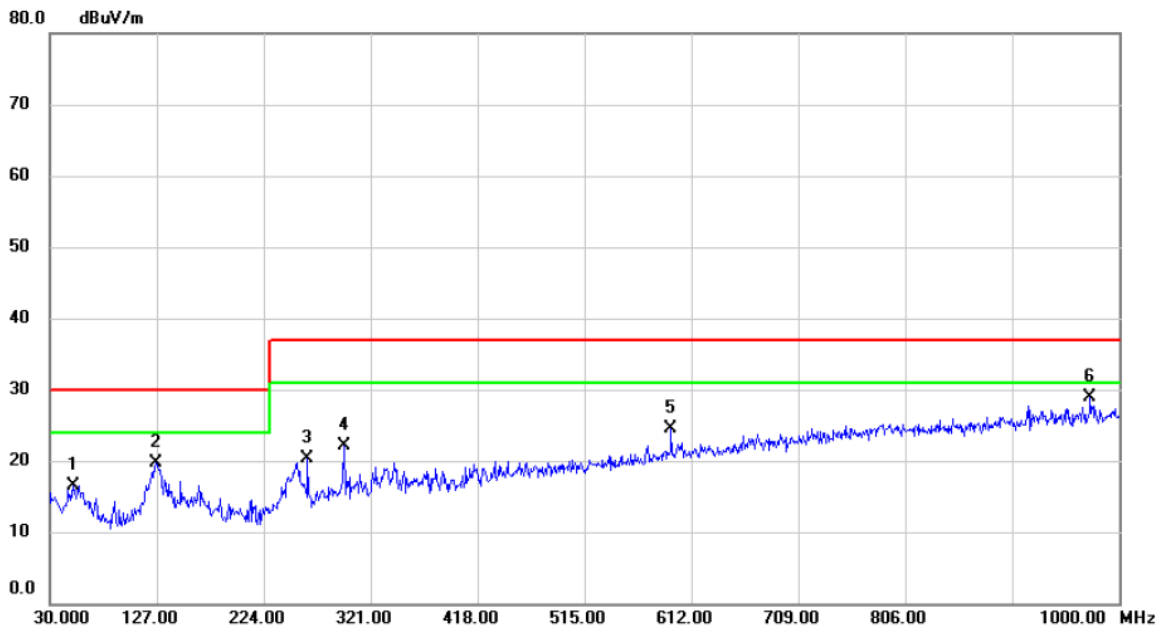

Figure C.2 – Boundary of EUT, Local AE and associated cabling

3.1.7 TEST RESULTS (UP TO 1 GHZ)

Test Voltage	AC 230V/50Hz	Polarization	Vertical
Test Mode	Mode 1		



No.	Mk.	Freq. MHz	Reading Level dBuV	Correct Factor dB	Measure- ment dBuV/m	Limit dBuV/m	Margin dB	Detector	Comment
1		51.3400	34.23	-17.70	16.53	30.00	-13.47	QP	
2		126.0300	38.88	-19.19	19.69	30.00	-10.31	QP	
3		263.7700	37.01	-16.74	20.27	37.00	-16.73	QP	
4		296.7500	37.57	-15.47	22.10	37.00	-14.90	QP	
5		593.5700	33.61	-9.07	24.54	37.00	-12.46	QP	
6	*	973.8100	34.20	-5.35	28.85	37.00	-8.15	QP	

Test Voltage	AC 230V/50Hz	Polarization	Horizontal
Test Mode	Mode 1		

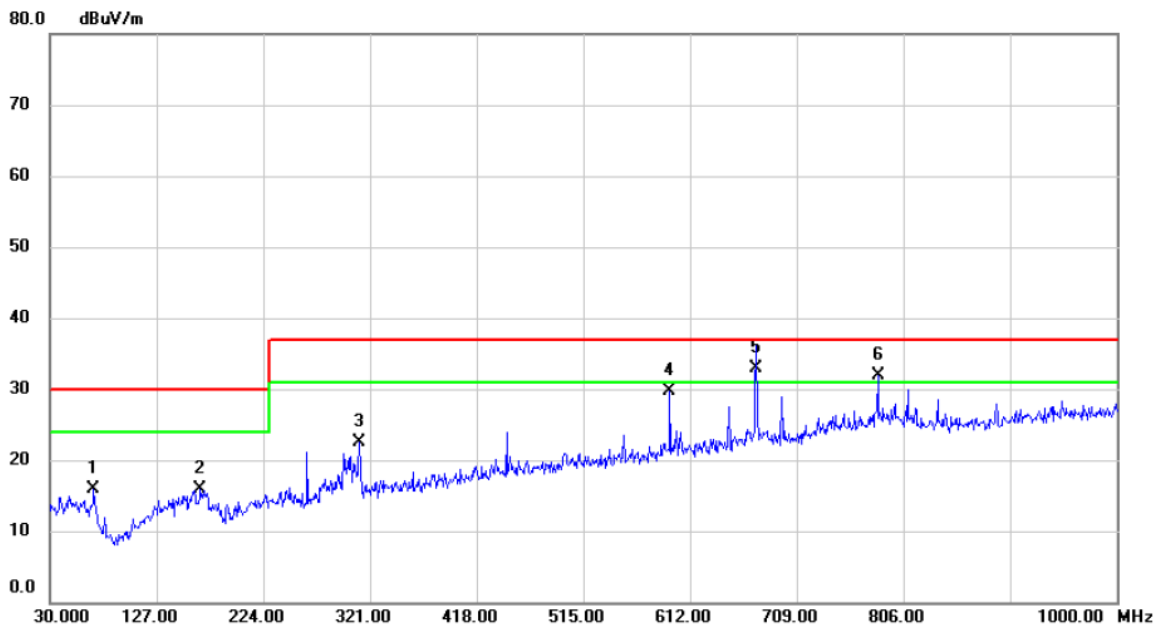

No. Mk.	Freq. MHz	Reading Level dBuV	Correct Factor dB	Measurement dBuV/m	Limit dBuV/m	Margin dB	Detector	Comment
1	69.7700	35.62	-19.65	15.97	30.00	-14.03	QP	
2	166.7700	32.40	-16.41	15.99	30.00	-14.01	QP	
3	311.3000	37.51	-14.93	22.58	37.00	-14.42	QP	
4	593.5700	38.60	-8.84	29.76	37.00	-7.24	QP	
5 *	672.1400	41.00	-8.01	32.99	37.00	-4.01	QP	
6 !	782.7200	38.54	-6.65	31.89	37.00	-5.11	QP	

Test Voltage	AC 230V/50Hz	Polarization	Vertical
Test Mode	Mode 3		

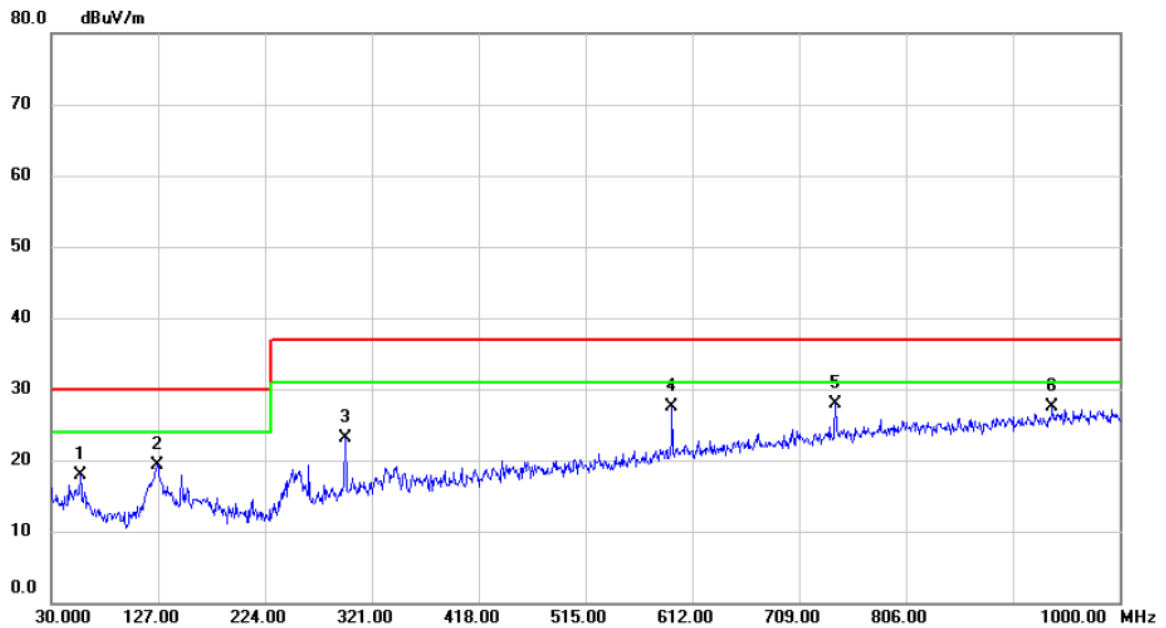

No.	Mk.	Freq. MHz	Reading Level dBuV	Correct Factor dB	Measure- ment dBuV/m	Limit dBuV/m	Margin dB	Detector	Comment
1		56.1900	35.56	-17.72	17.84	30.00	-12.16	QP	
2		126.0300	38.55	-19.19	19.36	30.00	-10.64	QP	
3		296.7500	38.64	-15.47	23.17	37.00	-13.83	QP	
4		593.5700	36.50	-9.07	27.43	37.00	-9.57	QP	
5	*	741.9800	35.32	-7.32	28.00	37.00	-9.00	QP	
6		938.8900	33.17	-5.69	27.48	37.00	-9.52	QP	

Test Voltage	AC 230V/50Hz	Polarization	Horizontal
Test Mode	Mode 3		

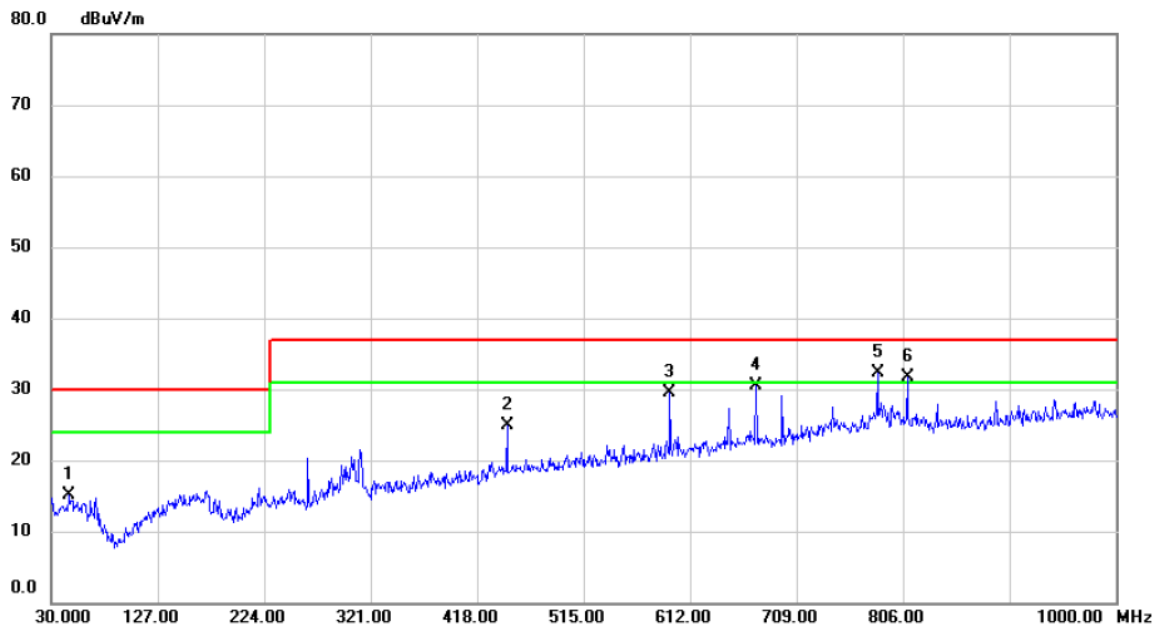

No.	Mk.	Freq. MHz	Reading Level dBuV	Correct Factor dB	Measure- ment dBuV/m	Limit dBuV/m	Margin dB	Detector	Comment
1		46.4900	32.84	-17.83	15.01	30.00	-14.99	QP	
2		445.1600	36.33	-11.40	24.93	37.00	-12.07	QP	
3		593.5700	38.41	-8.84	29.57	37.00	-7.43	QP	
4		672.1400	38.42	-8.01	30.41	37.00	-6.59	QP	
5	*	782.7200	38.96	-6.65	32.31	37.00	-4.69	QP	
6	!	809.8800	38.19	-6.50	31.69	37.00	-5.31	QP	

Test Voltage	AC 230V/50Hz	Polarization	Vertical
Test Mode	Mode 4		

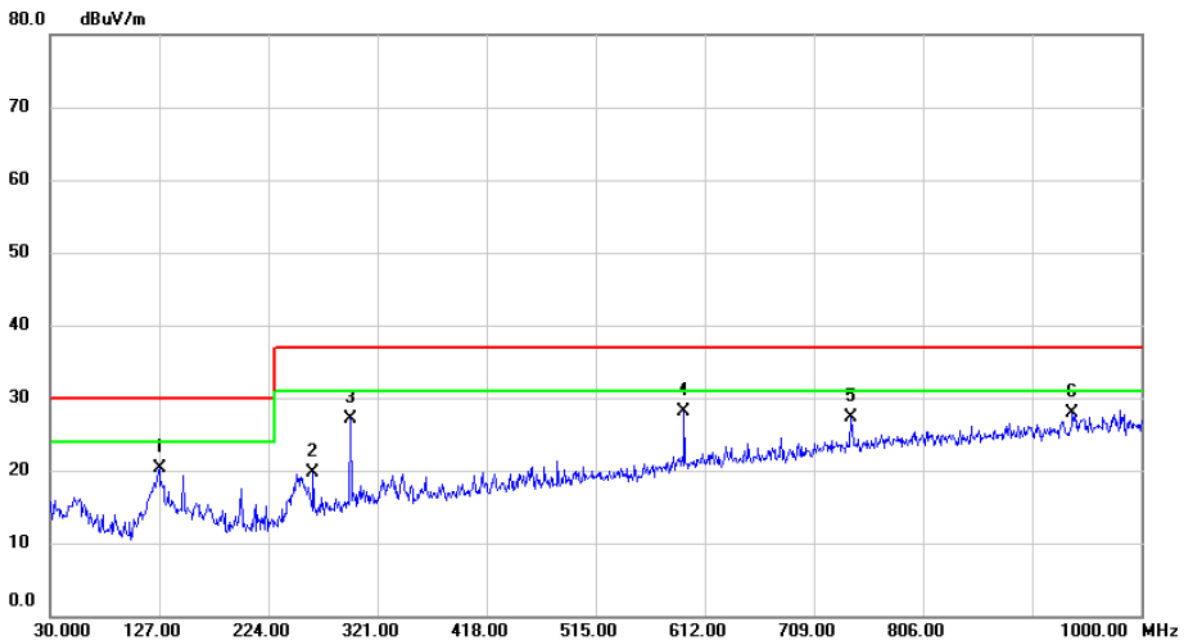

No.	Mk.	Freq. MHz	Reading Level dBuV	Correct Factor dB	Measure- ment dBuV/m	Limit dBuV/m	Margin dB	Detector	Comment
1		127.0000	39.29	-19.06	20.23	30.00	-9.77	QP	
2		263.7700	36.45	-16.74	19.71	37.00	-17.29	QP	
3		296.7500	42.59	-15.47	27.12	37.00	-9.88	QP	
4	*	593.5700	37.21	-9.07	28.14	37.00	-8.86	QP	
5		741.9800	34.70	-7.32	27.38	37.00	-9.62	QP	
6		938.8900	33.57	-5.69	27.88	37.00	-9.12	QP	

Test Voltage	AC 230V/50Hz	Polarization	Horizontal
Test Mode	Mode 4		

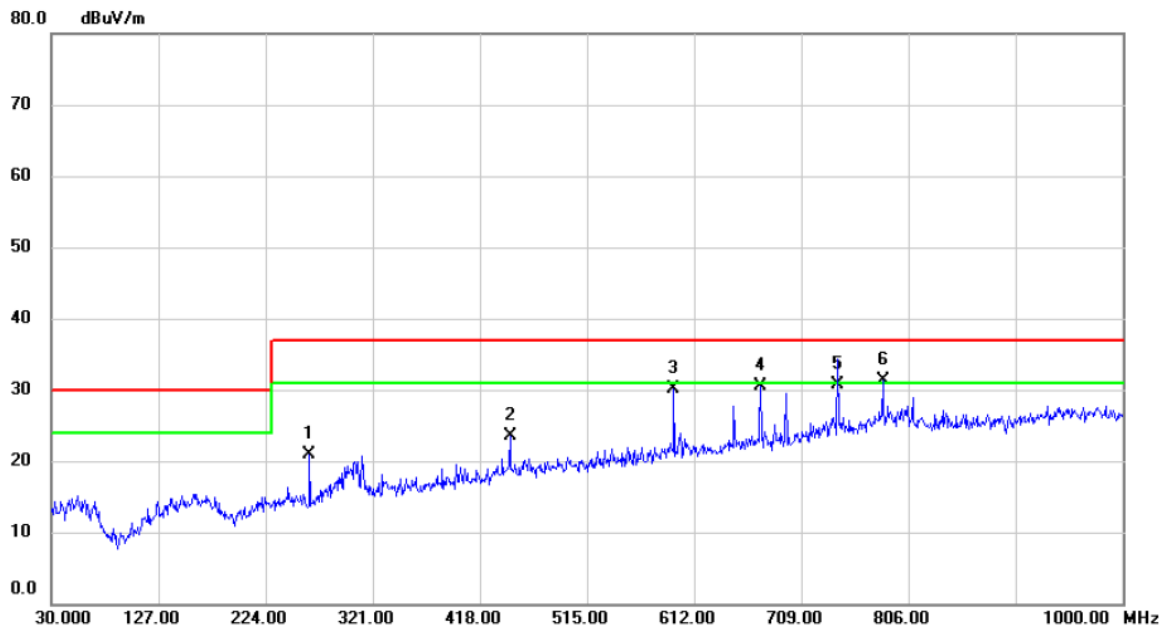

No.	Mk.	Freq. MHz	Reading Level dBuV	Correct Factor dB	Measure- ment dBuV/m	Limit dBuV/m	Margin dB	Detector	Comment
1		263.7700	37.47	-16.59	20.88	37.00	-16.12	QP	
2		445.1600	34.92	-11.40	23.52	37.00	-13.48	QP	
3		593.5700	39.01	-8.84	30.17	37.00	-6.83	QP	
4		672.1400	38.46	-8.01	30.45	37.00	-6.55	QP	
5		741.9800	37.78	-7.10	30.68	37.00	-6.32	QP	
6	*	782.7200	37.93	-6.65	31.28	37.00	-5.72	QP	

Test Voltage	AC 230V/50Hz	Polarization	Vertical
Test Mode	Mode 11		

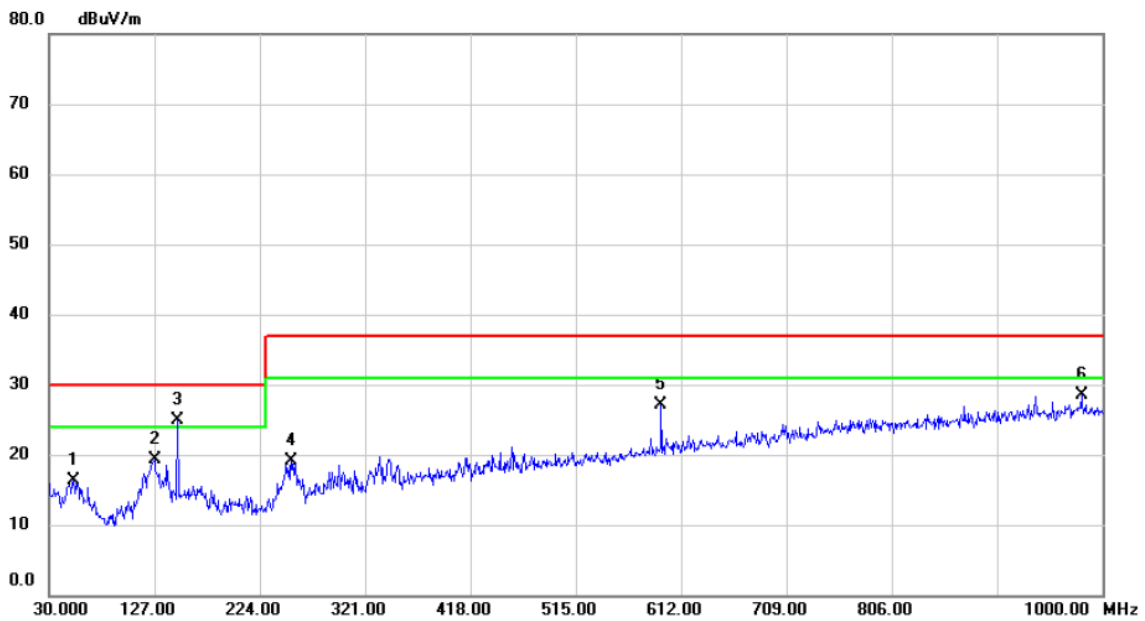

No. Mk.	Freq. MHz	Reading Level dBuV	Correct Factor dB	Measure- ment dBuV/m	Limit dBuV/m	Margin dB	Detector	Comment
1	52.3100	33.95	-17.69	16.26	30.00	-13.74	QP	
2	127.0000	38.43	-19.06	19.37	30.00	-10.63	QP	
3 *	148.3400	41.89	-17.03	24.86	30.00	-5.14	QP	
4	253.1000	36.22	-17.11	19.11	37.00	-17.89	QP	
5	593.5700	36.21	-9.07	27.14	37.00	-9.86	QP	
6	980.6000	33.86	-5.30	28.56	37.00	-8.44	QP	

Test Voltage	AC 230V/50Hz	Polarization	Horizontal
Test Mode	Mode 11		

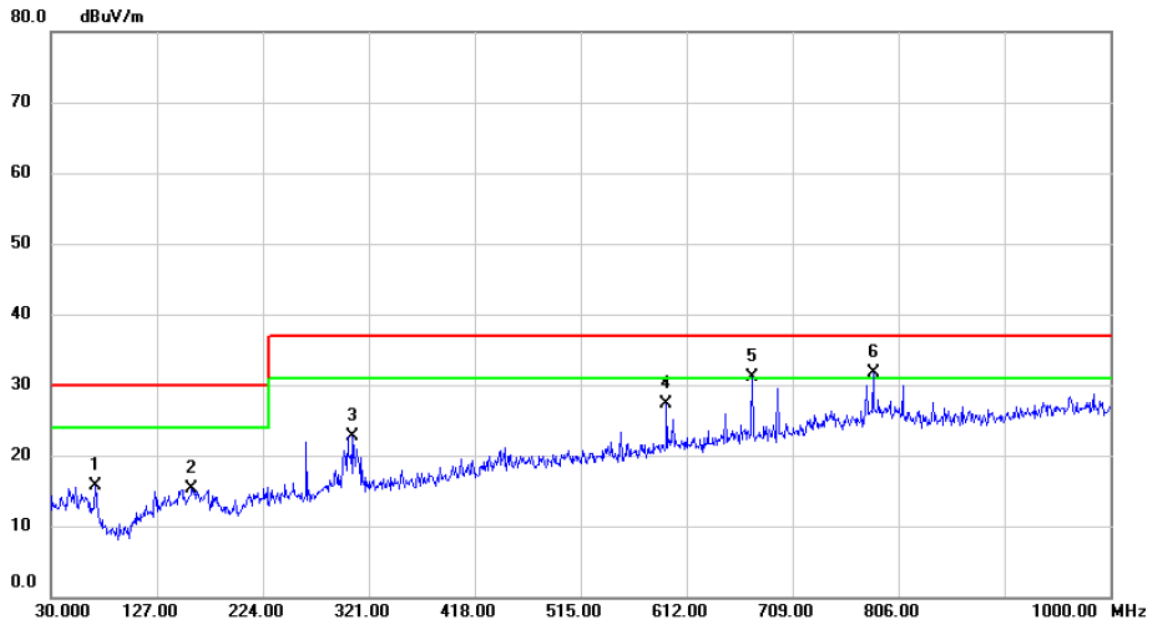

No.	Mk.	Freq. MHz	Reading Level dBuV	Correct Factor dB	Measure- ment dBuV/m	Limit dBuV/m	Margin dB	Detector	Comment
1		70.7400	35.55	-19.83	15.72	30.00	-14.28	QP	
2		159.0100	31.55	-16.26	15.29	30.00	-14.71	QP	
3		306.4500	37.88	-15.10	22.78	37.00	-14.22	QP	
4		593.5700	36.07	-8.84	27.23	37.00	-9.77	QP	
5	!	672.1400	39.20	-8.01	31.19	37.00	-5.81	QP	
6	*	782.7200	38.37	-6.65	31.72	37.00	-5.28	QP	

Test Voltage	AC 110V/60Hz	Polarization	Vertical
Test Mode	Mode 1		

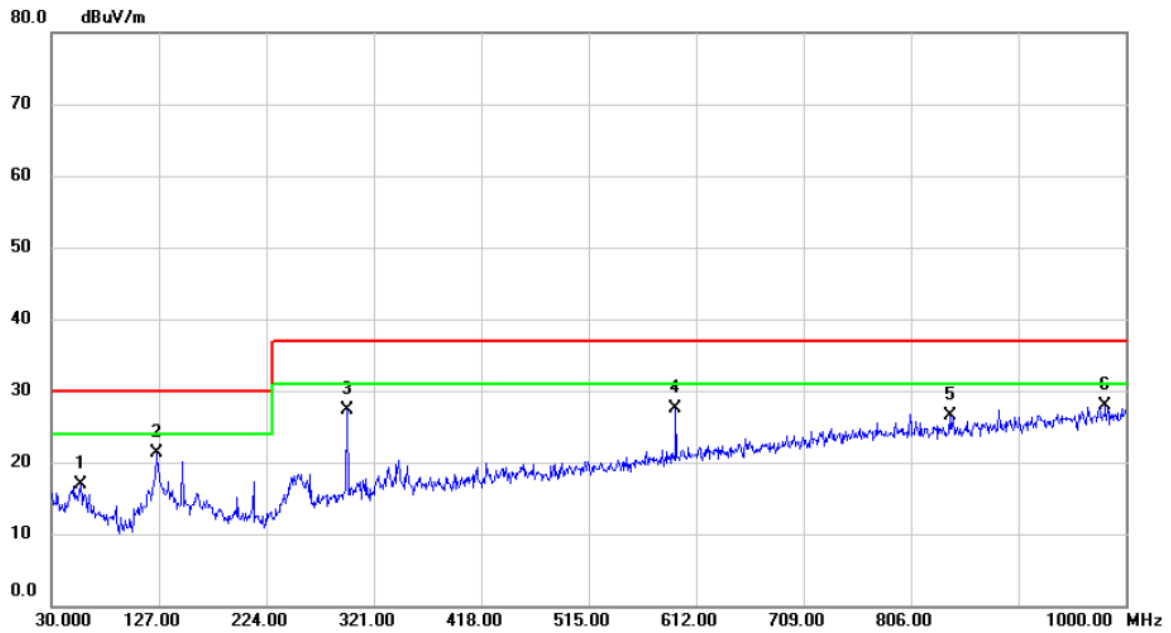

No. Mk.	Freq. MHz	Reading Level dBuV	Correct Factor dB	Measurement dBuV/m	Limit dBuV/m	Margin dB	Detector	Comment
1	56.1900	34.71	-17.72	16.99	30.00	-13.01	QP	
2 *	125.0600	40.57	-19.29	21.28	30.00	-8.72	QP	
3	296.7500	42.72	-15.47	27.25	37.00	-9.75	QP	
4	593.5700	36.63	-9.07	27.56	37.00	-9.44	QP	
5	840.9200	33.47	-6.99	26.48	37.00	-10.52	QP	
6	981.5700	33.25	-5.30	27.95	37.00	-9.05	QP	

Test Voltage	AC 110V/60Hz	Polarization	Horizontal
Test Mode	Mode 1		

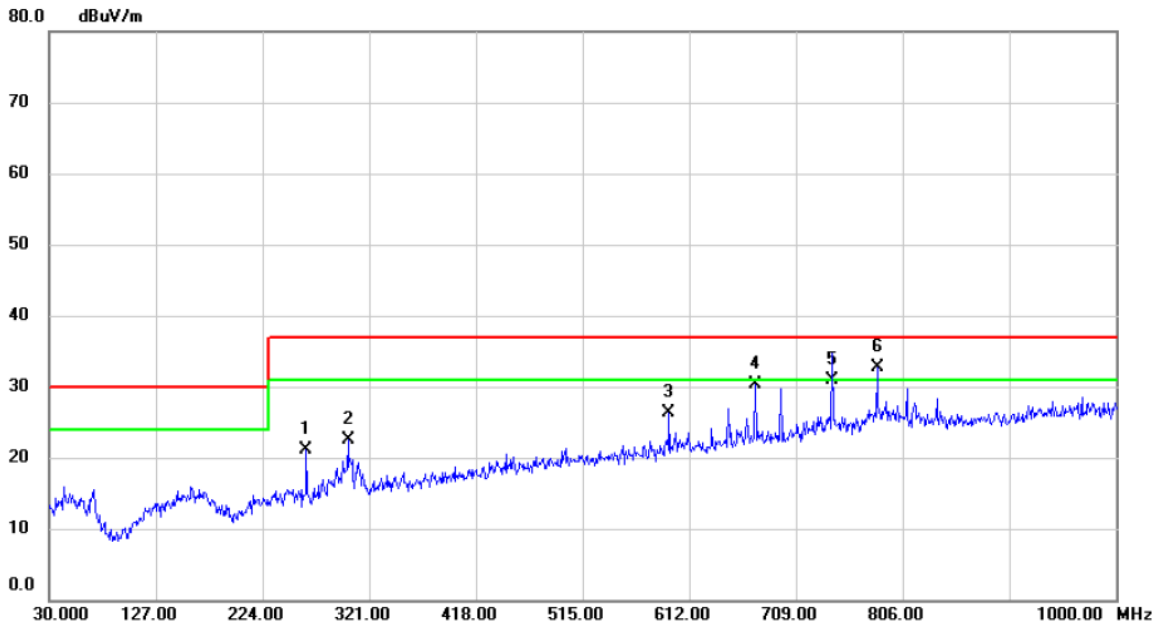

No.	Mk.	Freq. MHz	Reading Level dBuV	Correct Factor dB	Measure- ment dBuV/m	Limit dBuV/m	Margin dB	Detector	Comment
1		263.7700	37.71	-16.59	21.12	37.00	-15.88	QP	
2		301.6000	37.75	-15.26	22.49	37.00	-14.51	QP	
3		593.5700	35.12	-8.84	26.28	37.00	-10.72	QP	
4		672.1400	38.41	-8.01	30.40	37.00	-6.60	QP	
5		741.9800	37.95	-7.10	30.85	37.00	-6.15	QP	
6	*	782.7200	39.44	-6.65	32.79	37.00	-4.21	QP	

3.2 RADIATED EMISSION ABOVE 1 GHZ

3.2.1 LIMITS

Class B equipment above 1000MHz

Frequency MHz	Measurement		Class B limit dB(uV/m)
	Distance m	Detector type/bandwidth	FSOATS
1000-3000	3	Average / 1 MHz	50
3000-6000			54
1000-3000		Peak / 1 MHz	70
3000-6000			74

Notes:

- (1) The limit for radiated test was performed according to as following: EN 55032
- (2) The tighter limit applies at the band edges.
- (3) Emission level (dBuV/m)=20log Emission level (uV/m).
- (4) The test result calculated as following:
 Measurement Value = Reading Level + Correct Factor
 Correct Factor = Antenna Factor + Cable Loss - Amplifier Gain(if use)
 Margin Level = Measurement Value - Limit Value

Required highest frequency for radiated measurement

Highest internal frequency (F_x) MHz	Highest measured frequency MHz
$F_x \leq 108$	1000
$108 < F_x \leq 500$	2000
$500 < F_x \leq 1000$	5000
$F_x > 1000$	5 th up to a maximum 6 GHz,

Note for FM and TV broadcast receiver, F_x is determined from the highest frequency generated or used excluding the local oscillator and tuned frequencies.

3.2.2 MEASUREMENT INSTRUMENTS LIST

Item	Kind of Equipment	Manufacturer	Type No.	Series Model	Calibrated until
1	Horn Antenna	EMCO	3115	9605-4803	May 12, 2021
2	Amplifier	Agilent	8449B	3008A02333	Mar. 01, 2021
3	MXE EMI Receiver	Agilent	N9038A	MY53220133	Feb. 28, 2021
4	Measurement Software	Farad	EZ-EMC Ver.BTL-2ANT-1	N/A	N/A
5	Multi-Device Controller	ETS-Lindgren	2090	N/A	N/A
6	Controller	MF	MF-7802	MF780208159	N/A
7	Cable	Micable Inc.	B10-01-01-5M	18047123	Feb. 28, 2021
8	Cable	Micable Inc.	B10-01-01-12M	18072743	Feb. 28, 2021
9	Cable	RegalWay	RWLPS50-7.9A- SMSM-1M	20200102 001	Feb. 28, 2021

Remark: "N/A" denotes no model no., no serial no. or no calibration specified.

All calibration period of equipment list is one year.

3.2.3 TEST PROCEDURE

- The measuring distance of 3 m shall be used for measurements. The EUT was placed on the top of a rotating table 0.8 meter above the ground at a 10 meter semi-anechoic chamber. The table was rotated 360 degrees to determine the position of the highest radiation.(above 1GHz)
- The height of the equipment or of the substitution antenna shall be 0.8 m, the height of the test antenna shall vary between 1 m to 4 m. Both horizontal and vertical polarizations of the antenna are set to make the measurement.
- The initial step in collecting radiated emission data is a receiver peak detector mode pre-scanning the measurement frequency range. Significant peaks are then marked and then Quasi Peak detector mode re-measured.
- All readings are Peak Mode value unless otherwise stated AVG in column of Note. If the Peak Mode Measured value compliance with the Peak Limits and lower than AVG Limits, the EUT shall be deemed to meet both Peak & AVG Limits and then only Peak Mode was measured, but AVG Mode didn't perform. (above 1GHz)
- For the actual test configuration, please refer to the related Item - Block Diagram of system tested.

3.2.4 DEVIATION FROM TEST STANDARD

No deviation

3.2.5 TEST SETUP

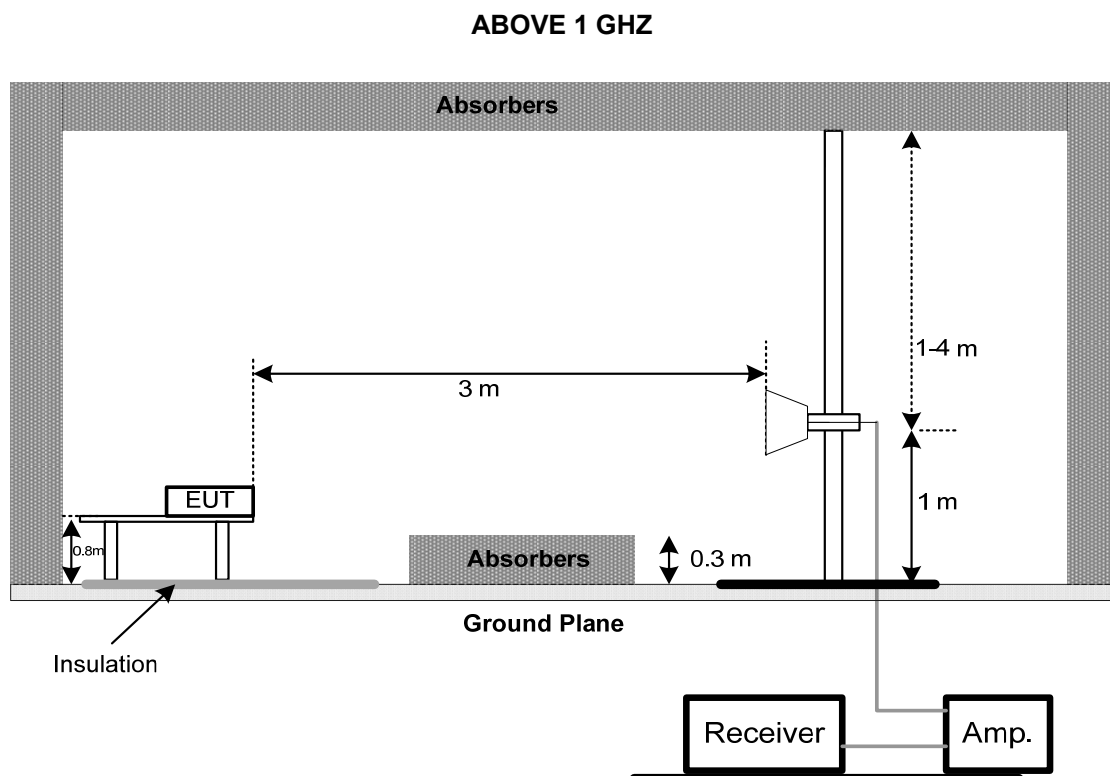

3.2.6 MEASUREMENT DISTANCE

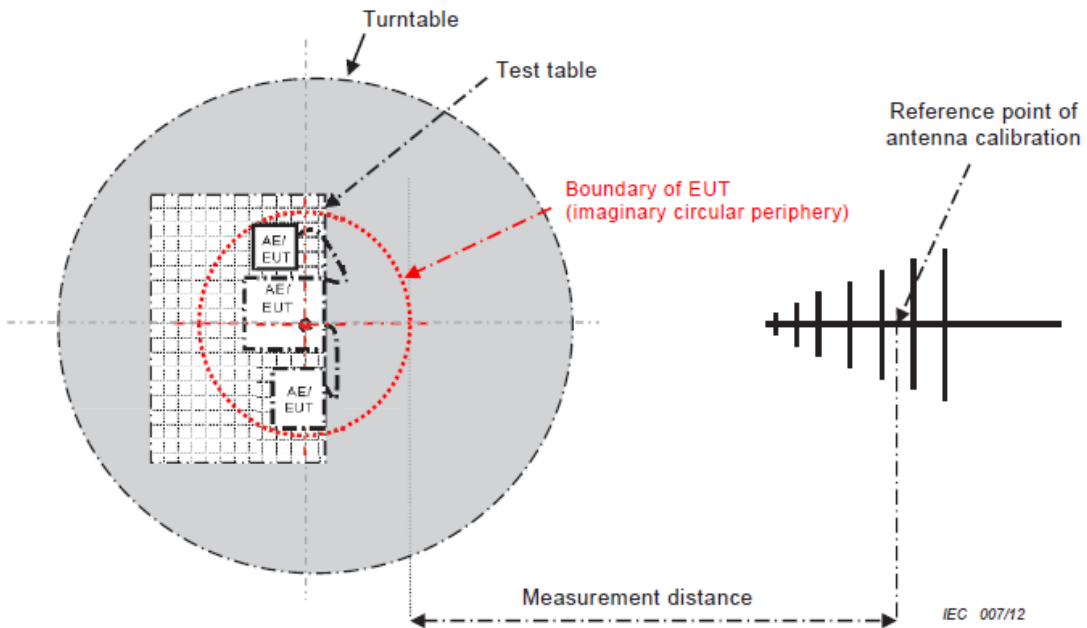

- 34 -

CISPR 32 © IEC:2012

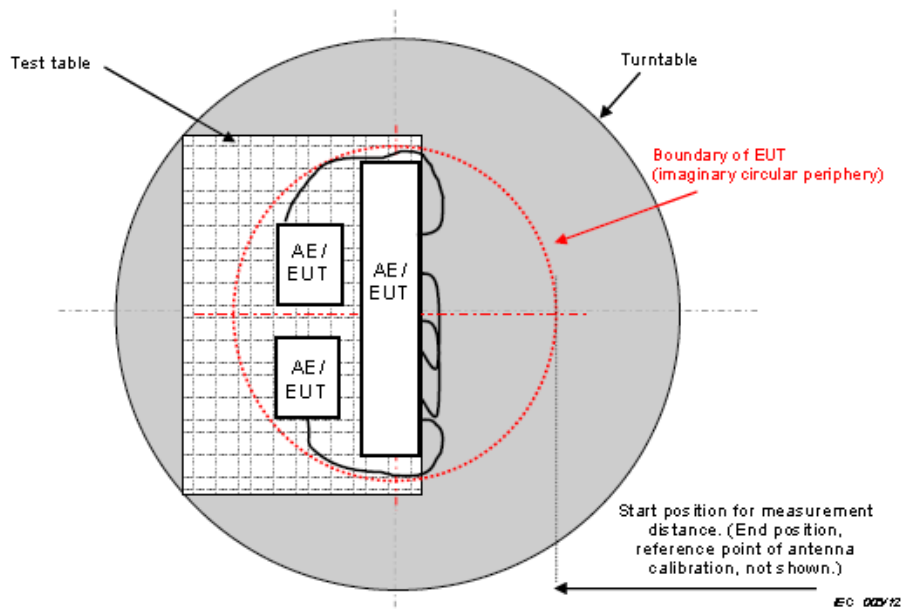
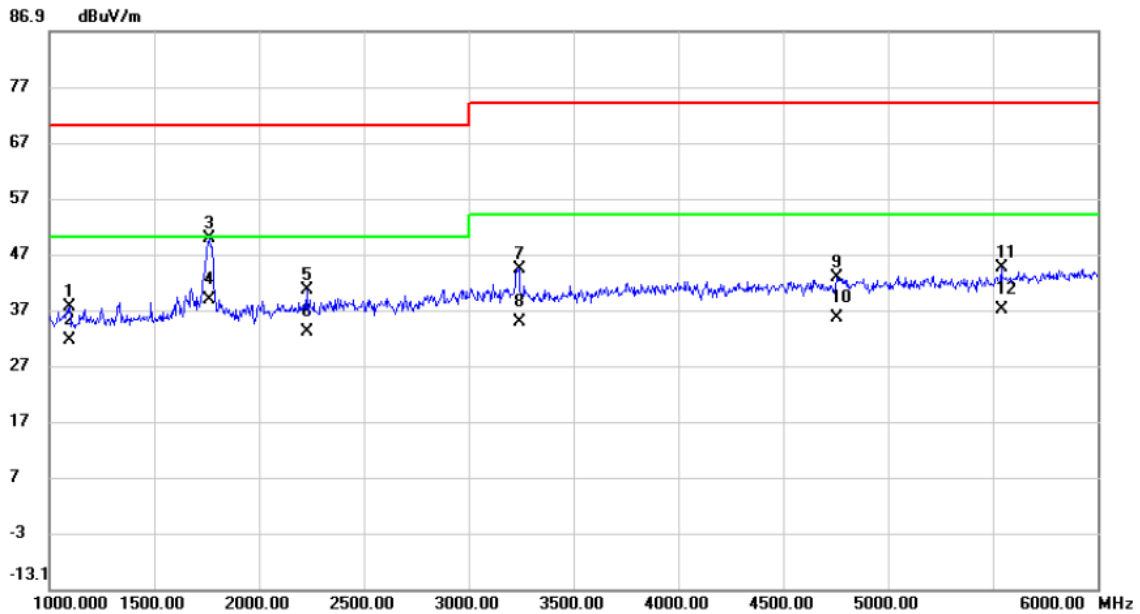

Figure C.2 – Boundary of EUT, Local AE and associated cabling

3.2.7 TEST RESULTS (ABOVE 1 GHZ)

Test Voltage	AC 230V/50Hz	Polarization	Vertical
Test Mode	Mode 1		



No.	Mk.	Freq.	Reading Level	Correct Factor	Measurement	Limit	Margin	Detector	Comment
		MHz	dBuV	dB	dBuV/m	dBuV/m	dB		
1		1095.000	42.28	-4.73	37.55	70.00	-32.45	peak	
2		1095.000	36.31	-4.73	31.58	50.00	-18.42	AVG	
3		1765.000	50.95	-1.28	49.67	70.00	-20.33	peak	
4	*	1765.000	40.00	-1.28	38.72	50.00	-11.28	AVG	
5		2227.500	39.57	1.04	40.61	70.00	-29.39	peak	
6		2227.500	32.10	1.04	33.14	50.00	-16.86	AVG	
7		3240.000	39.28	5.10	44.38	74.00	-29.62	peak	
8		3240.000	29.65	5.10	34.75	54.00	-19.25	AVG	
9		4755.000	33.07	9.65	42.72	74.00	-31.28	peak	
10		4755.000	25.95	9.65	35.60	54.00	-18.40	AVG	
11		5540.000	32.85	11.57	44.42	74.00	-29.58	peak	
12		5540.000	25.38	11.57	36.95	54.00	-17.05	AVG	

Test Voltage	AC 230V/50Hz	Polarization	Horizontal
Test Mode	Mode 1		

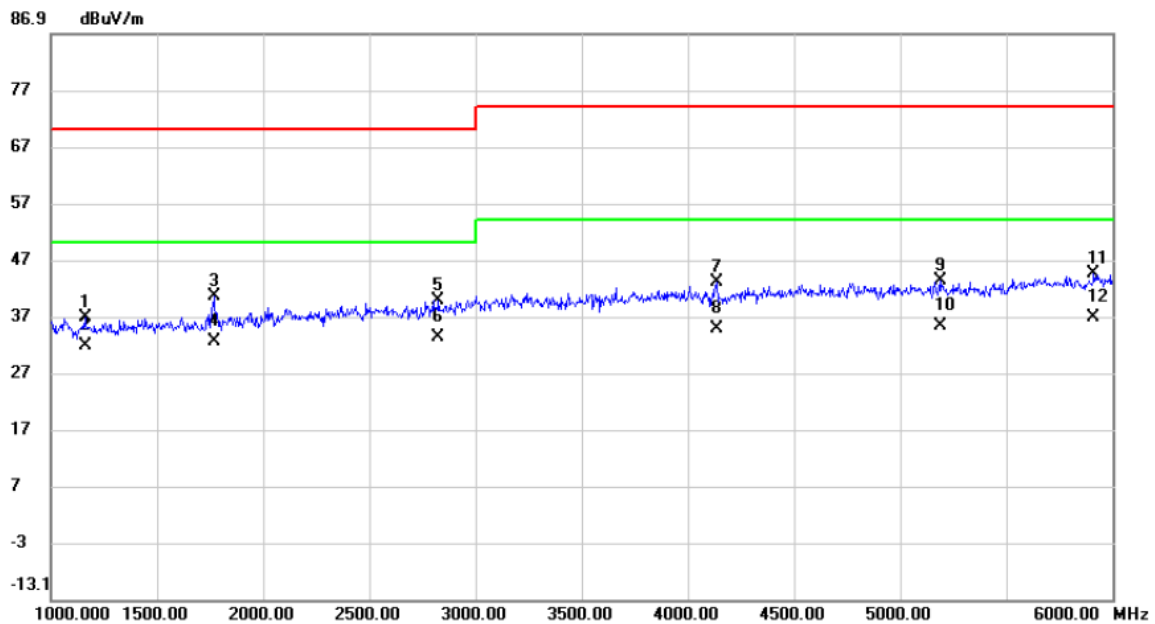

No.	Mk.	Freq. MHz	Reading Level dBuV	Correct Factor dB	Measure- ment dBuV/m	Limit dBuV/m	Margin dB	Detector	Comment
1		1160.000	41.29	-4.46	36.83	70.00	-33.17	peak	
2		1160.000	36.30	-4.46	31.84	50.00	-18.16	AVG	
3		1767.500	41.77	-1.27	40.50	70.00	-29.50	peak	
4		1767.500	33.82	-1.27	32.55	50.00	-17.45	AVG	
5		2825.000	36.30	3.55	39.85	70.00	-30.15	peak	
6	*	2825.000	29.61	3.55	33.16	50.00	-16.84	AVG	
7		4137.500	34.51	8.49	43.00	74.00	-31.00	peak	
8		4137.500	26.26	8.49	34.75	54.00	-19.25	AVG	
9		5187.500	32.53	10.64	43.17	74.00	-30.83	peak	
10		5187.500	24.62	10.64	35.26	54.00	-18.74	AVG	
11		5912.500	31.63	12.85	44.48	74.00	-29.52	peak	
12		5912.500	23.95	12.85	36.80	54.00	-17.20	AVG	

Test Voltage	AC 230V/50Hz	Polarization	Vertical
Test Mode	Mode 3		

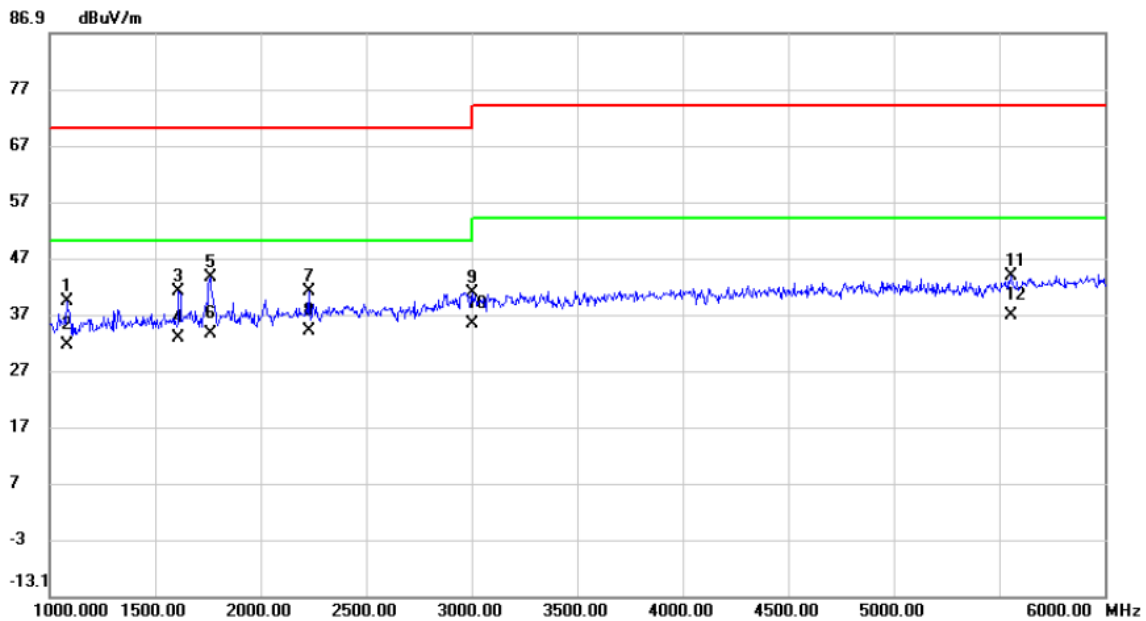

No. Mk.	Freq. MHz	Reading Level dBuV	Correct Factor dB	Measurement dBuV/m	Limit dBuV/m	Margin dB	Detector	Comment
1	1082.500	43.97	-4.79	39.18	70.00	-30.82	peak	
2	1082.500	36.29	-4.79	31.50	50.00	-18.50	AVG	
3	1612.500	43.39	-2.26	41.13	70.00	-28.87	peak	
4	1612.500	34.95	-2.26	32.69	50.00	-17.31	AVG	
5	1760.000	44.83	-1.32	43.51	70.00	-26.49	peak	
6	1760.000	34.79	-1.32	33.47	50.00	-16.53	AVG	
7	2227.500	40.06	1.04	41.10	70.00	-28.90	peak	
8 *	2227.500	33.11	1.04	34.15	50.00	-15.85	AVG	
9	3002.500	36.52	4.38	40.90	74.00	-33.10	peak	
10	3002.500	30.85	4.38	35.23	54.00	-18.77	AVG	
11	5557.500	32.10	11.63	43.73	74.00	-30.27	peak	
12	5557.500	25.21	11.63	36.84	54.00	-17.16	AVG	

Test Voltage	AC 230V/50Hz	Polarization	Horizontal
Test Mode	Mode 3		

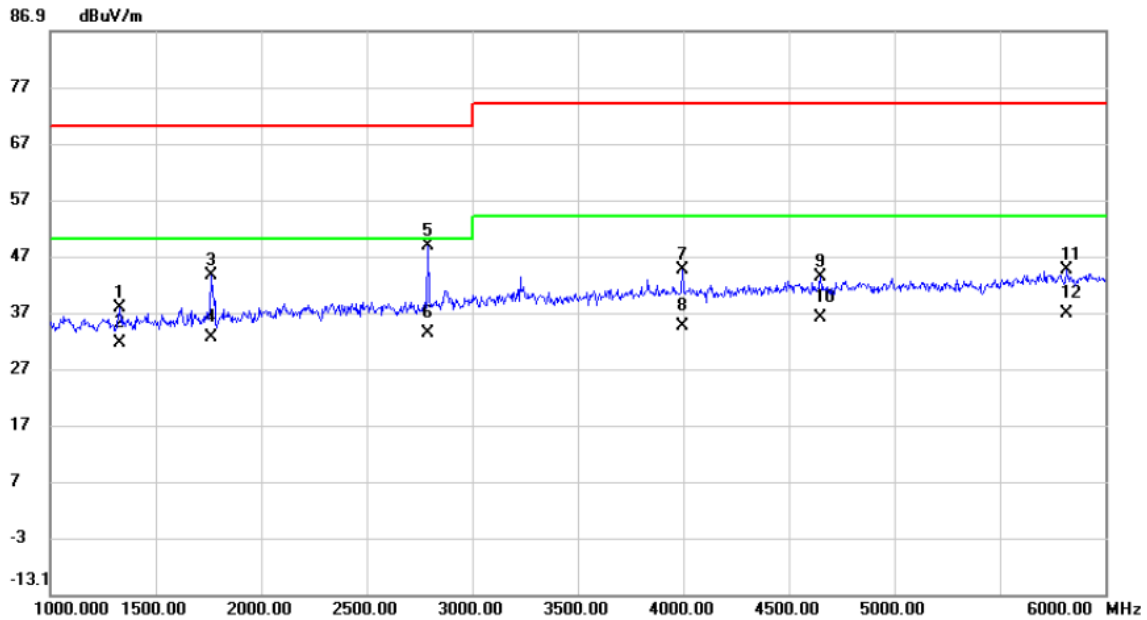

No.	Mk.	Freq. MHz	Reading Level dBuV	Correct Factor dB	Measure- ment dBuV/m	Limit dBuV/m	Margin dB	Detector	Comment
1		1330.000	41.61	-3.72	37.89	70.00	-32.11	peak	
2		1330.000	35.22	-3.72	31.50	50.00	-18.50	AVG	
3		1762.500	44.89	-1.30	43.59	70.00	-26.41	peak	
4		1762.500	33.78	-1.30	32.48	50.00	-17.52	AVG	
5		2792.500	45.41	3.40	48.81	70.00	-21.19	peak	
6	*	2792.500	29.76	3.40	33.16	50.00	-16.84	AVG	
7		3995.000	36.39	8.23	44.62	74.00	-29.38	peak	
8		3995.000	26.30	8.23	34.53	54.00	-19.47	AVG	
9		4650.000	33.83	9.43	43.26	74.00	-30.74	peak	
10		4650.000	26.54	9.43	35.97	54.00	-18.03	AVG	
11		5815.000	31.99	12.52	44.51	74.00	-29.49	peak	
12		5815.000	24.36	12.52	36.88	54.00	-17.12	AVG	

Test Voltage	AC 230V/50Hz	Polarization	Vertical
Test Mode	Mode 4		

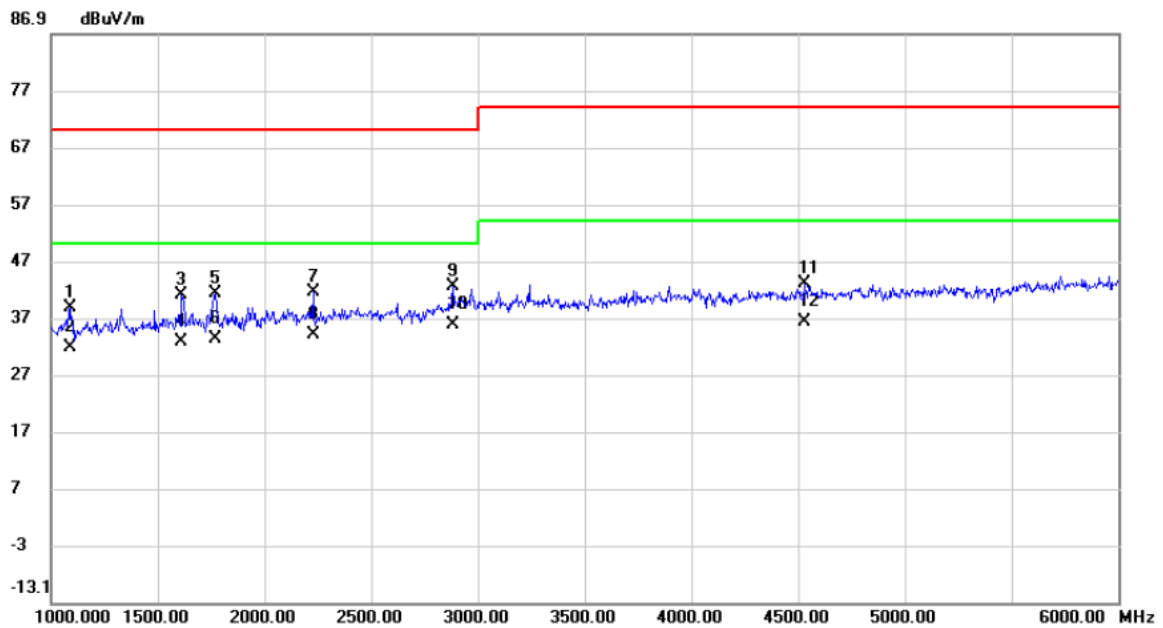

No.	Mk.	Freq. MHz	Reading Level dBuV	Correct Factor dB	Measure- ment dBuV/m	Limit dBuV/m	Margin dB	Detector	Comment
1		1087.500	43.54	-4.75	38.79	70.00	-31.21	peak	
2		1087.500	36.61	-4.75	31.86	50.00	-18.14	AVG	
3		1612.500	43.22	-2.26	40.96	70.00	-29.04	peak	
4		1612.500	34.95	-2.26	32.69	50.00	-17.31	AVG	
5		1770.000	42.42	-1.25	41.17	70.00	-28.83	peak	
6		1770.000	34.65	-1.25	33.40	50.00	-16.60	AVG	
7		2227.500	40.60	1.04	41.64	70.00	-28.36	peak	
8		2227.500	33.11	1.04	34.15	50.00	-15.85	AVG	
9		2880.000	38.83	3.81	42.64	70.00	-27.36	peak	
10	*	2880.000	31.96	3.81	35.77	50.00	-14.23	AVG	
11		4527.500	33.97	9.16	43.13	74.00	-30.87	peak	
12		4527.500	27.04	9.16	36.20	54.00	-17.80	AVG	

Test Voltage	AC 230V/50Hz	Polarization	Horizontal
Test Mode	Mode 4		

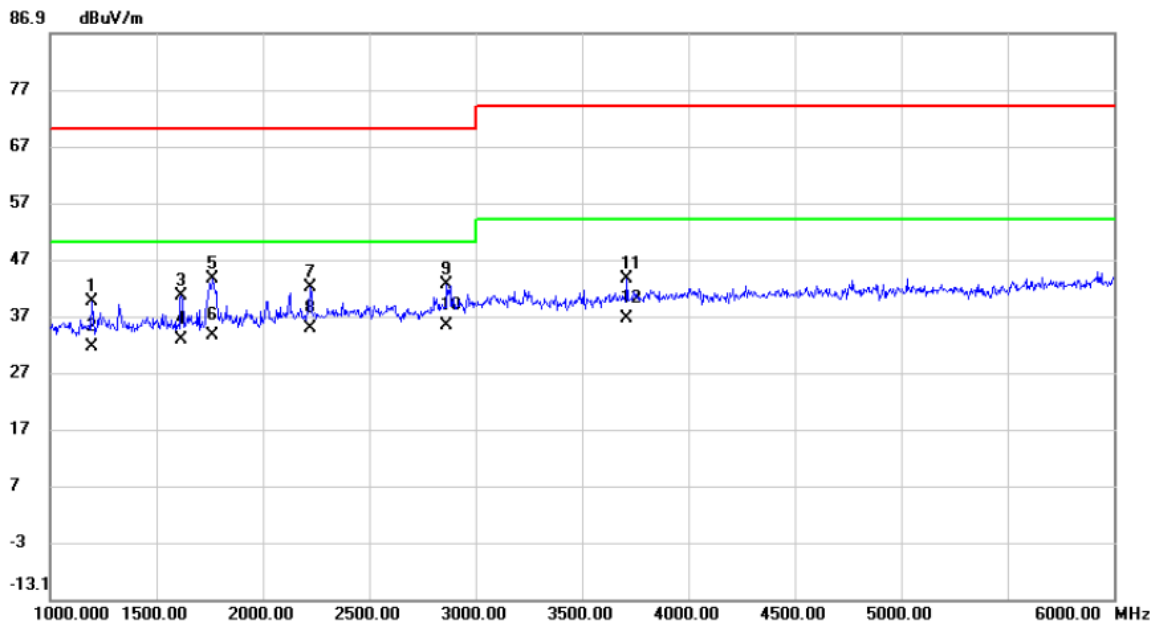

No. Mk.	Freq. MHz	Reading Level dBuV	Correct Factor dB	Measurement dBuV/m	Limit dBuV/m	Margin dB	Detector	Comment
1	1195.000	43.74	-4.30	39.44	70.00	-30.56	peak	
2	1195.000	35.80	-4.30	31.50	50.00	-18.50	AVG	
3	1617.500	42.78	-2.23	40.55	70.00	-29.45	peak	
4	1617.500	34.92	-2.23	32.69	50.00	-17.31	AVG	
5	1762.500	44.84	-1.30	43.54	70.00	-26.46	peak	
6	1762.500	34.78	-1.30	33.48	50.00	-16.52	AVG	
7	2222.500	40.99	1.03	42.02	70.00	-27.98	peak	
8	2222.500	33.72	1.03	34.75	50.00	-15.25	AVG	
9	2865.000	38.83	3.74	42.57	70.00	-27.43	peak	
10 *	2865.000	31.42	3.74	35.16	50.00	-14.84	AVG	
11	3712.500	36.58	6.90	43.48	74.00	-30.52	peak	
12	3712.500	29.69	6.90	36.59	54.00	-17.41	AVG	

Test Voltage	AC 230V/50Hz	Polarization	Vertical
Test Mode	Mode 11		

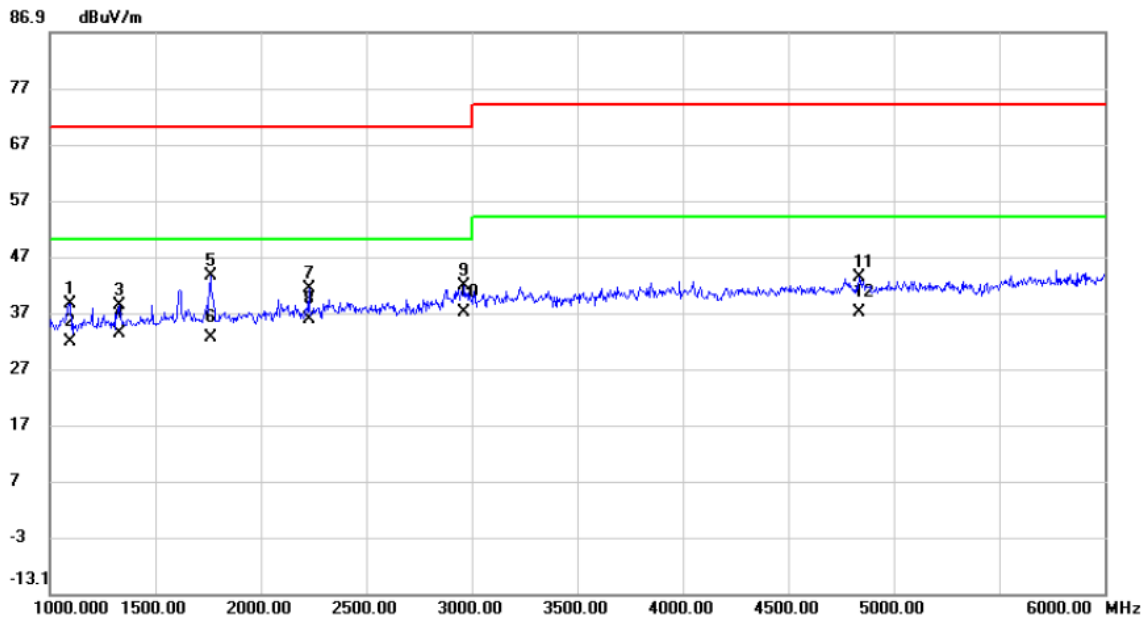

No. Mk.	Freq. MHz	Reading Level dBuV	Correct Factor dB	Measure- ment dBuV/m	Limit dBuV/m	Margin dB	Detector	Comment
1	1095.000	43.27	-4.73	38.54	70.00	-31.46	peak	
2	1095.000	36.57	-4.73	31.84	50.00	-18.16	AVG	
3	1332.500	42.04	-3.71	38.33	70.00	-31.67	peak	
4	1332.500	36.95	-3.71	33.24	50.00	-16.76	AVG	
5	1760.000	44.83	-1.32	43.51	70.00	-26.49	peak	
6	1760.000	33.94	-1.32	32.62	50.00	-17.38	AVG	
7	2227.500	40.30	1.04	41.34	70.00	-28.66	peak	
8	2227.500	34.82	1.04	35.86	50.00	-14.14	AVG	
9	2965.000	37.46	4.21	41.67	70.00	-28.33	peak	
10 *	2965.000	32.73	4.21	36.94	50.00	-13.06	AVG	
11	4837.500	33.49	9.82	43.31	74.00	-30.69	peak	
12	4837.500	27.29	9.82	37.11	54.00	-16.89	AVG	

Test Voltage	AC 230V/50Hz	Polarization	Horizontal
Test Mode	Mode 11		

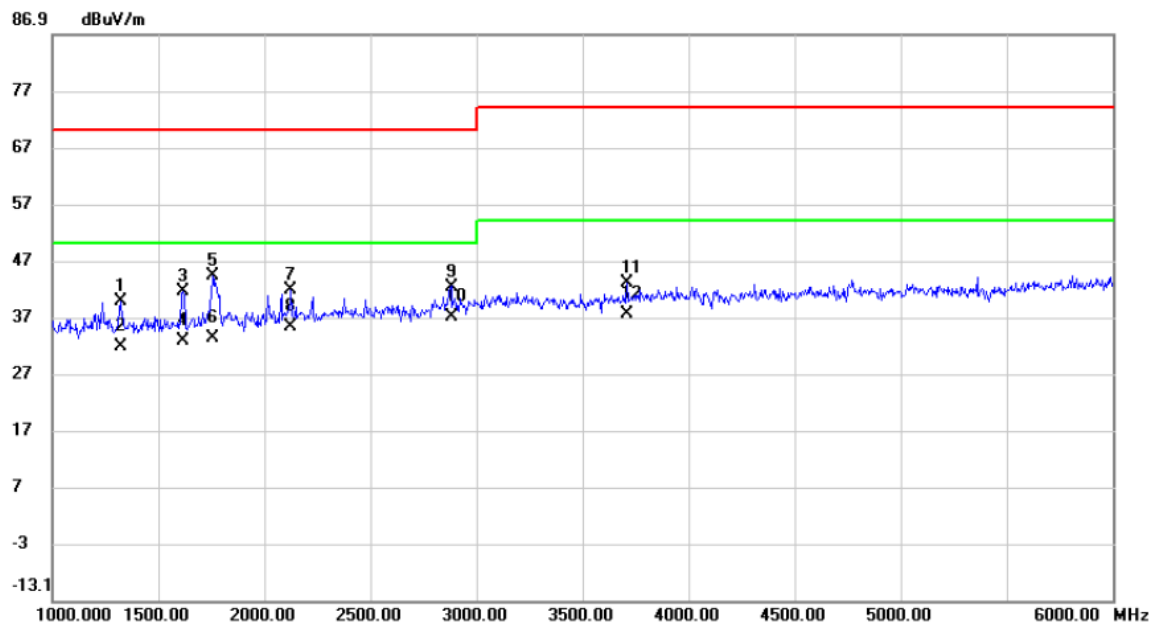

No.	Mk.	Freq. MHz	Reading Level dBuV	Correct Factor dB	Measure- ment dBuV/m	Limit dBuV/m	Margin dB	Detector	Comment
1		1322.500	43.64	-3.75	39.89	70.00	-30.11	peak	
2		1322.500	35.50	-3.75	31.75	50.00	-18.25	AVG	
3		1617.500	43.80	-2.23	41.57	70.00	-28.43	peak	
4		1617.500	34.89	-2.23	32.66	50.00	-17.34	AVG	
5		1757.500	45.64	-1.34	44.30	70.00	-25.70	peak	
6		1757.500	34.74	-1.34	33.40	50.00	-16.60	AVG	
7		2125.000	40.99	0.67	41.66	70.00	-28.34	peak	
8		2125.000	34.71	0.67	35.38	50.00	-14.62	AVG	
9		2880.000	38.59	3.81	42.40	70.00	-27.60	peak	
10	*	2880.000	33.11	3.81	36.92	50.00	-13.08	AVG	
11		3712.500	36.01	6.90	42.91	74.00	-31.09	peak	
12		3712.500	30.54	6.90	37.44	54.00	-16.56	AVG	

Test Voltage	AC 110V/60Hz	Polarization	Vertical
Test Mode	Mode 1		

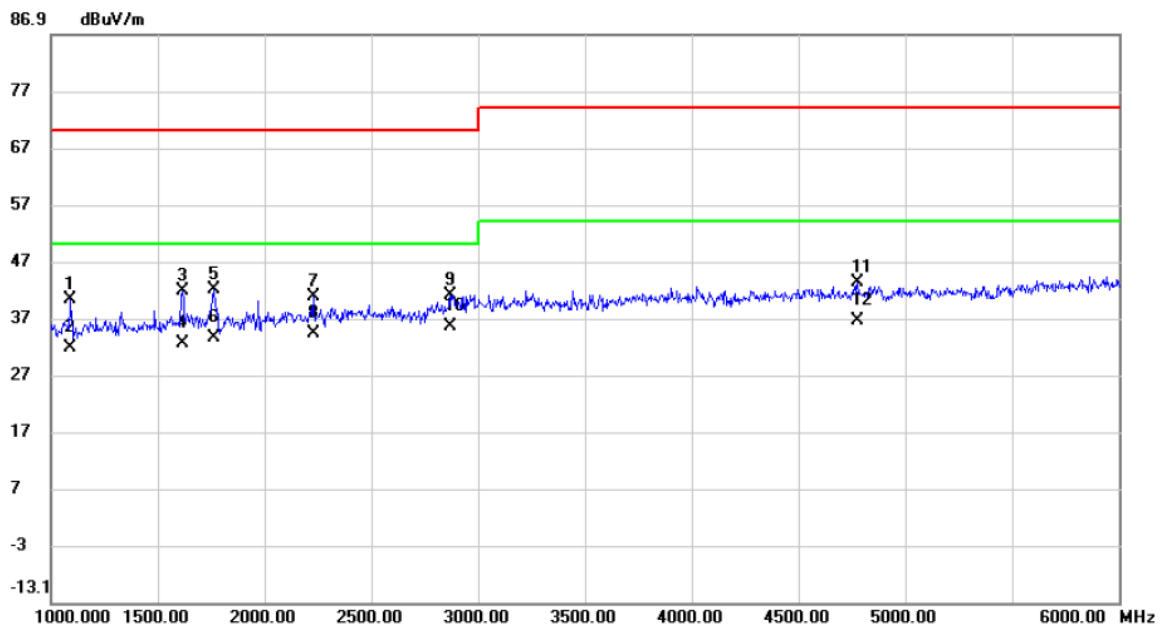

No.	Mk.	Freq. MHz	Reading Level dBuV	Correct Factor dB	Measure- ment dBuV/m	Limit dBuV/m	Margin dB	Detector	Comment
1		1090.000	44.91	-4.75	40.16	70.00	-29.84	peak	
2		1090.000	36.60	-4.75	31.85	50.00	-18.15	AVG	
3		1615.000	43.95	-2.25	41.70	70.00	-28.30	peak	
4		1615.000	34.89	-2.25	32.64	50.00	-17.36	AVG	
5		1760.000	43.41	-1.32	42.09	70.00	-27.91	peak	
6		1760.000	34.79	-1.32	33.47	50.00	-16.53	AVG	
7		2227.500	39.68	1.04	40.72	70.00	-29.28	peak	
8		2227.500	33.14	1.04	34.18	50.00	-15.82	AVG	
9		2867.500	37.37	3.74	41.11	70.00	-28.89	peak	
10	*	2867.500	31.89	3.74	35.63	50.00	-14.37	AVG	
11		4775.000	33.51	9.69	43.20	74.00	-30.80	peak	
12		4775.000	26.81	9.69	36.50	54.00	-17.50	AVG	

Test Voltage	AC 110V/60Hz	Polarization	Horizontal
Test Mode	Mode 1		

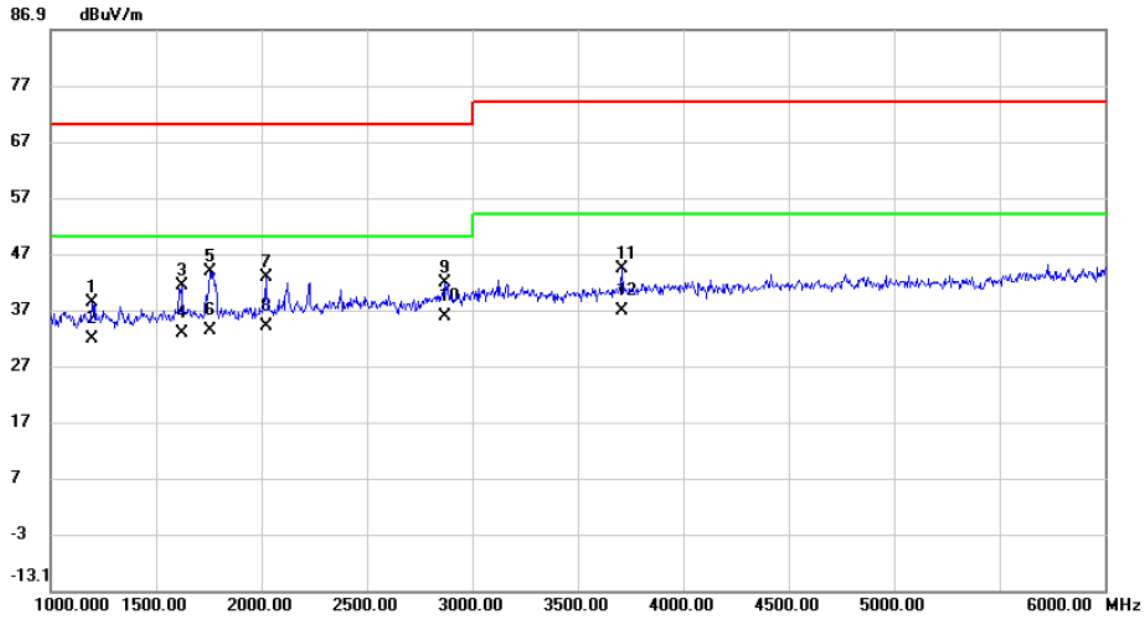

No.	Mk.	Freq. MHz	Reading Level dBuV	Correct Factor dB	Measure- ment dBuV/m	Limit dBuV/m	Margin dB	Detector	Comment
1		1197.500	42.57	-4.29	38.28	70.00	-31.72	peak	
2		1197.500	36.14	-4.29	31.85	50.00	-18.15	AVG	
3		1620.000	43.58	-2.22	41.36	70.00	-28.64	peak	
4		1620.000	34.91	-2.22	32.69	50.00	-17.31	AVG	
5		1757.500	45.18	-1.34	43.84	70.00	-26.16	peak	
6		1757.500	34.74	-1.34	33.40	50.00	-16.60	AVG	
7		2022.500	42.46	0.31	42.77	70.00	-27.23	peak	
8		2022.500	33.84	0.31	34.15	50.00	-15.85	AVG	
9		2872.500	38.11	3.77	41.88	70.00	-28.12	peak	
10	*	2872.500	32.00	3.77	35.77	50.00	-14.23	AVG	
11		3712.500	37.33	6.90	44.23	74.00	-29.77	peak	
12		3712.500	29.94	6.90	36.84	54.00	-17.16	AVG	

3.3 CONDUCTED EMISSION MEASUREMENT AT AC MAINS POWER PORTS

3.3.1 LIMITS

Requirements for conducted emissions from AC mains power ports of Class B equipment

Frequency Range MHz	Coupling Device	Detector Type / bandwidth	Class B Limits (dB(μV))
0.15 - 0.5	AMN	Quasi Peak / 9 kHz	66-56
0.5 - 5			56
5 - 30			60
0.15 - 0.5	AMN	Average / 9 kHz	56 46
0.5 - 5			46
5 - 30			50

NOTE:

(1) The test result calculated as following:

Measurement Value = Reading Level + Correct Factor

Correct Factor = Insertion Loss + Cable Loss + Attenuator Factor(if use)

Margin Level = Measurement Value – Limit Value

3.3.2 MEASUREMENT INSTRUMENTS LIST

Item	Kind of Equipment	Manufacturer	Type No.	Series Model	Calibrated until
1	50Ω Terminator	SHX	TF2-3G-A	8122901	Feb. 28, 2021
2	TWO-LINE V-NETWORK	R&S	ENV216	100526	Mar. 01, 2021
3	EMI Test Receiver	R&S	ESR3	101862	Jul. 25, 2021
4	Artificial-Mains Network	SCHWARZBECK	NSLK 8127	8127685	Mar. 01, 2021
5	Cable	N/A	RG400	N/A(12m)	Mar. 10, 2021
6	Measurement Software	Farad	EZ-EMC Ver.NB-03A1-01	N/A	N/A

Remark: "N/A" denotes no model name, serial no. or calibration specified.

All calibration period of equipment list is one year.

3.3.3 TEST PROCEDURE

- a. The EUT was placed 0.8 meters from the horizontal ground plane with EUT being connected to the power mains through a line impedance stabilization network (LISN). All other support equipments powered from additional LISN(s). The LISN provide 50 Ohm/ 50uH of coupling impedance for the measuring instrument.
- b. Interconnecting cables that hang closer than 40 cm to the ground plane shall be folded back and forth in the center forming a bundle 30 to 40 cm long.
- c. I/O cables that are not connected to a peripheral shall be bundled in the center. The end of the cable may be terminated, if required, using the correct terminating impedance. The overall length shall not exceed 1 m.
- d. LISN at least 80 cm from nearest part of EUT chassis.
- e. For the actual test configuration, please refer to the related Item –EUT Test Photos.

3.3.4 DEVIATION FROM TEST STANDARD

No deviation

3.3.5 TEST SETUP

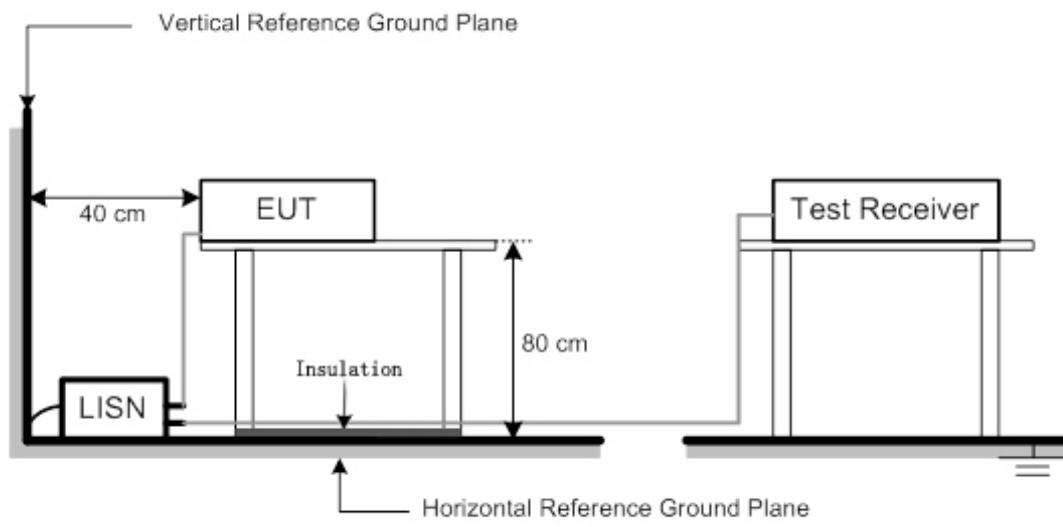

3.3.6 TEST RESULTS

Test Voltage	AC 230V/50Hz	Phase	Line
Test Mode	Mode 1		

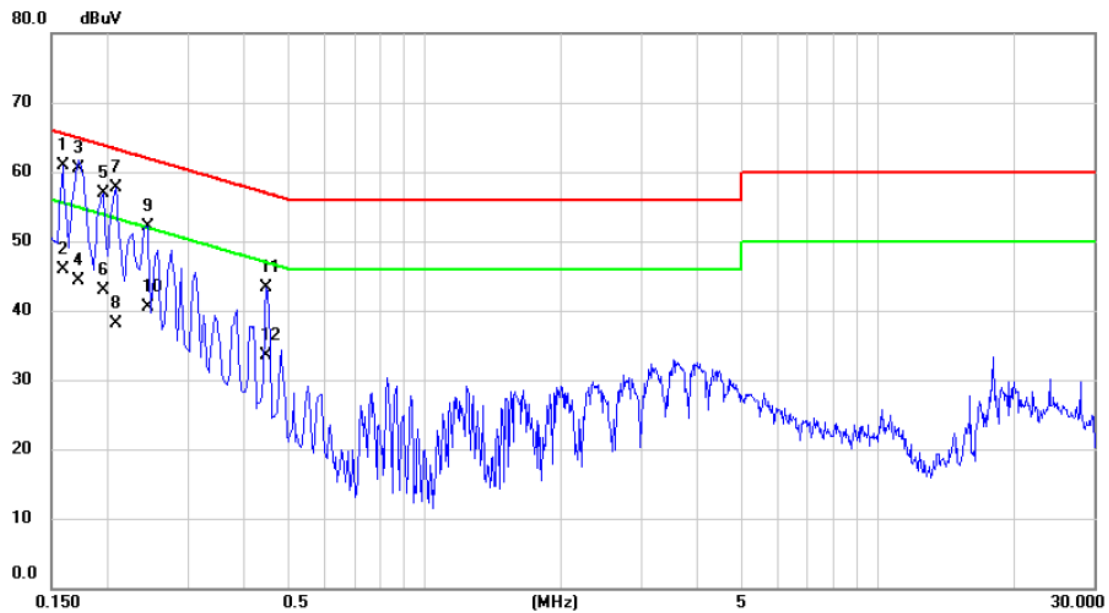

No.	Mk.	Freq. MHz	Reading Level dBuV	Correct Factor dB	Measure- ment dBuV	Limit dBuV	Margin dB	Detector	Comment
1		0.1590	51.11	9.73	60.84	65.52	-4.68	QP	
2		0.1590	36.20	9.73	45.93	55.52	-9.59	AVG	
3	*	0.1725	50.60	9.83	60.43	64.84	-4.41	QP	
4		0.1725	34.40	9.83	44.23	54.84	-10.61	AVG	
5		0.1950	46.98	9.90	56.88	63.82	-6.94	QP	
6		0.1950	33.10	9.90	43.00	53.82	-10.82	AVG	
7		0.2085	47.72	9.90	57.62	63.26	-5.64	QP	
8		0.2085	28.30	9.90	38.20	53.26	-15.06	AVG	
9		0.2445	42.16	9.87	52.03	61.94	-9.91	QP	
10		0.2445	30.70	9.87	40.57	51.94	-11.37	AVG	
11		0.4470	33.44	9.91	43.35	56.93	-13.58	QP	
12		0.4470	23.60	9.91	33.51	46.93	-13.42	AVG	

Test Voltage	AC 230V/50Hz	Phase	Neutral
Test Mode	Mode 1		

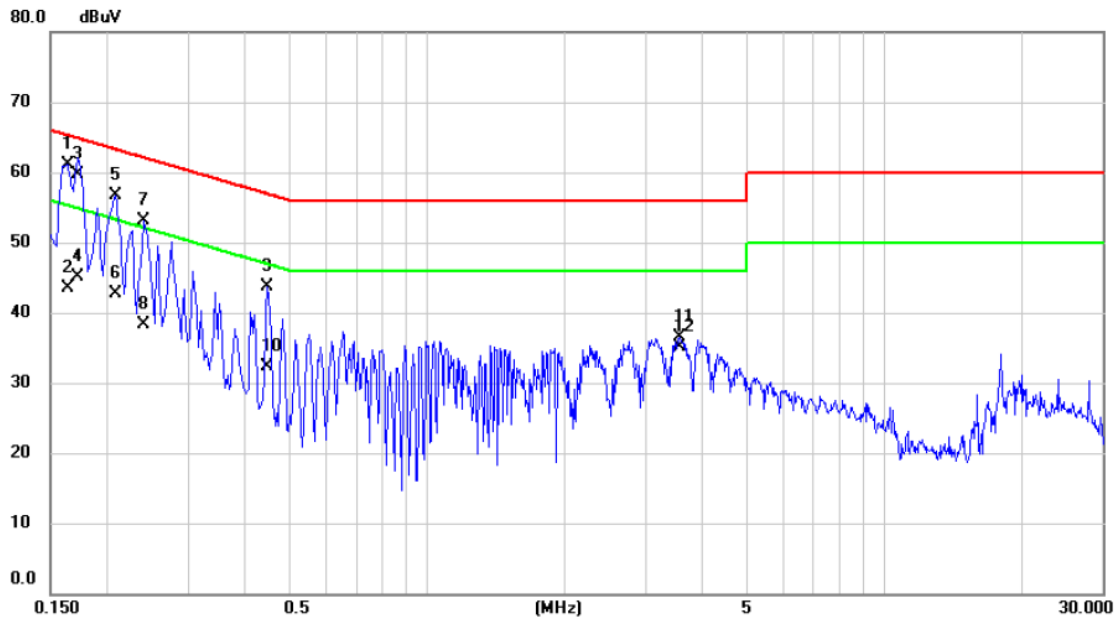

No.	Mk.	Freq. MHz	Reading Level dBuV	Correct Factor dB	Measure- ment dBuV	Limit dBuV	Margin dB	Detector	Comment
1	*	0.1635	51.26	9.85	61.11	65.28	-4.17	QP	
2		0.1635	33.60	9.85	43.45	55.28	-11.83	AVG	
3		0.1725	49.80	9.91	59.71	64.84	-5.13	QP	
4		0.1725	35.20	9.91	45.11	54.84	-9.73	AVG	
5		0.2085	46.79	10.00	56.79	63.26	-6.47	QP	
6		0.2085	32.70	10.00	42.70	53.26	-10.56	AVG	
7		0.2400	43.11	9.98	53.09	62.10	-9.01	QP	
8		0.2400	28.30	9.98	38.28	52.10	-13.82	AVG	
9		0.4470	33.61	10.09	43.70	56.93	-13.23	QP	
10		0.4470	22.20	10.09	32.29	46.93	-14.64	AVG	
11		3.5745	26.07	10.52	36.59	56.00	-19.41	QP	
12		3.5745	24.60	10.52	35.12	46.00	-10.88	AVG	

Test Voltage	AC 230V/50Hz	Phase	Line
Test Mode	Mode 3		

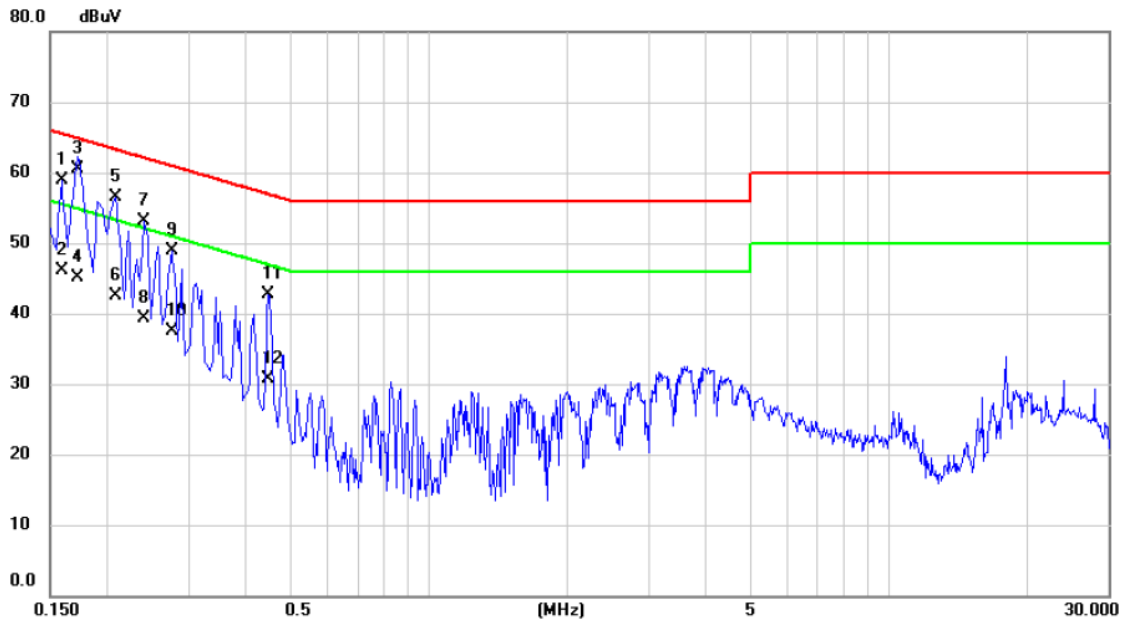

No.	Mk.	Freq. MHz	Reading Level dBuV	Correct Factor dB	Measure- ment dBuV	Limit dBuV	Margin dB	Detector	Comment
1		0.1590	49.16	9.73	58.89	65.52	-6.63	QP	
2		0.1590	36.30	9.73	46.03	55.52	-9.49	AVG	
3	*	0.1725	50.60	9.83	60.43	64.84	-4.41	QP	
4		0.1725	35.20	9.83	45.03	54.84	-9.81	AVG	
5		0.2085	46.65	9.90	56.55	63.26	-6.71	QP	
6		0.2085	32.70	9.90	42.60	53.26	-10.66	AVG	
7		0.2400	43.31	9.88	53.19	62.10	-8.91	QP	
8		0.2400	29.40	9.88	39.28	52.10	-12.82	AVG	
9		0.2760	39.12	9.88	49.00	60.94	-11.94	QP	
10		0.2760	27.60	9.88	37.48	50.94	-13.46	AVG	
11		0.4470	32.89	9.91	42.80	56.93	-14.13	QP	
12		0.4470	20.80	9.91	30.71	46.93	-16.22	AVG	

Test Voltage	AC 230V/50Hz	Phase	Neutral
Test Mode	Mode 3		

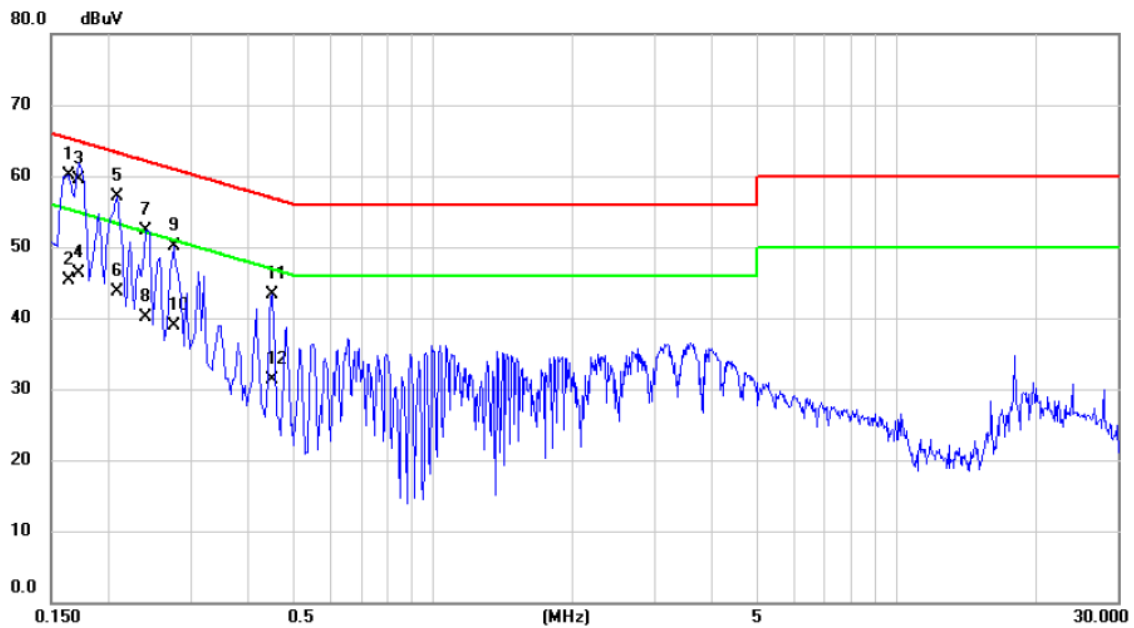

No. Mk.	Freq. MHz	Reading Level dBuV	Correct Factor dB	Measurement dBuV	Limit dBuV	Margin dB	Detector	Comment
1 *	0.1635	50.24	9.85	60.09	65.28	-5.19	QP	
2	0.1635	35.40	9.85	45.25	55.28	-10.03	AVG	
3	0.1725	49.60	9.91	59.51	64.84	-5.33	QP	
4	0.1725	36.30	9.91	46.21	54.84	-8.63	AVG	
5	0.2085	47.16	10.00	57.16	63.26	-6.10	QP	
6	0.2085	33.70	10.00	43.70	53.26	-9.56	AVG	
7	0.2400	42.35	9.98	52.33	62.10	-9.77	QP	
8	0.2400	30.20	9.98	40.18	52.10	-11.92	AVG	
9	0.2760	40.08	9.99	50.07	60.94	-10.87	QP	
10	0.2760	28.90	9.99	38.89	50.94	-12.05	AVG	
11	0.4515	33.12	10.10	43.22	56.85	-13.63	QP	
12	0.4515	21.20	10.10	31.30	46.85	-15.55	AVG	

Test Voltage	AC 230V/50Hz	Phase	Line
Test Mode	Mode 4		

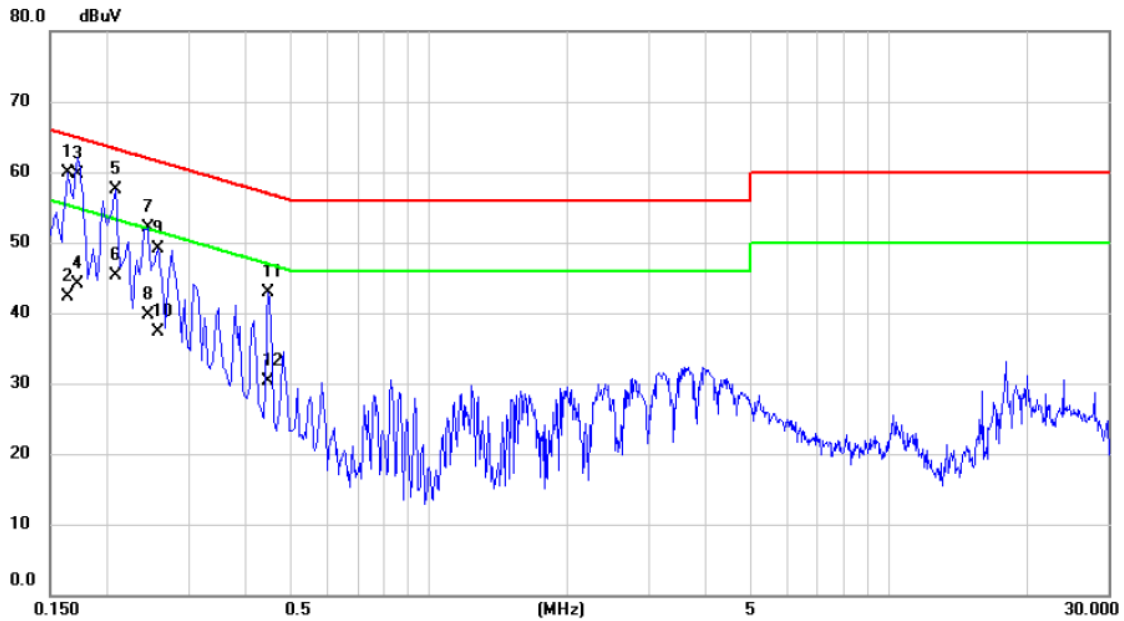

No.	Mk.	Freq. MHz	Reading Level dBuV	Correct Factor dB	Measure- ment dBuV	Limit dBuV	Margin dB	Detector	Comment
1		0.1635	50.21	9.77	59.98	65.28	-5.30	QP	
2		0.1635	32.60	9.77	42.37	55.28	-12.91	AVG	
3	*	0.1725	49.80	9.83	59.63	64.84	-5.21	QP	
4		0.1725	34.30	9.83	44.13	54.84	-10.71	AVG	
5		0.2085	47.59	9.90	57.49	63.26	-5.77	QP	
6		0.2085	35.40	9.90	45.30	53.26	-7.96	AVG	
7		0.2445	42.21	9.87	52.08	61.94	-9.86	QP	
8		0.2445	29.80	9.87	39.67	51.94	-12.27	AVG	
9		0.2580	39.16	9.87	49.03	61.50	-12.47	QP	
10		0.2580	27.40	9.87	37.27	51.50	-14.23	AVG	
11		0.4470	32.92	9.91	42.83	56.93	-14.10	QP	
12		0.4470	20.40	9.91	30.31	46.93	-16.62	AVG	

Test Voltage	AC 230V/50Hz	Phase	Neutral
Test Mode	Mode 4		

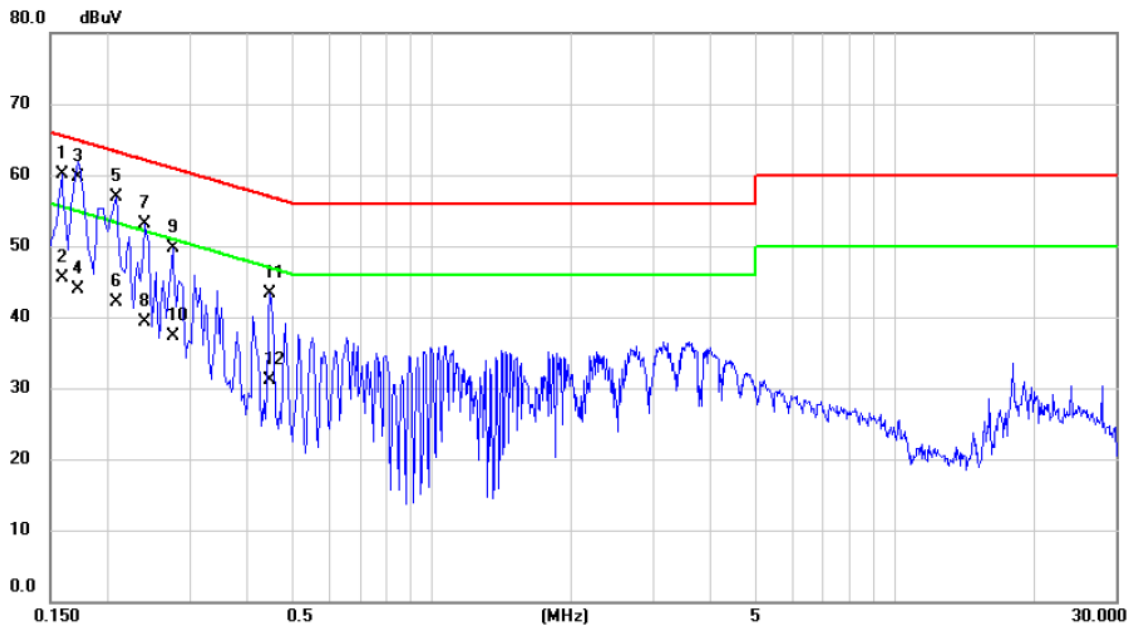

No. Mk.	Freq. MHz	Reading Level dBuV	Correct Factor dB	Measure- ment dBuV	Limit dBuV	Margin dB	Detector	Comment
1	0.1590	50.32	9.81	60.13	65.52	-5.39	QP	
2	0.1590	35.60	9.81	45.41	55.52	-10.11	AVG	
3 *	0.1725	49.80	9.91	59.71	64.84	-5.13	QP	
4	0.1725	34.00	9.91	43.91	54.84	-10.93	AVG	
5	0.2085	46.91	10.00	56.91	63.26	-6.35	QP	
6	0.2085	32.10	10.00	42.10	53.26	-11.16	AVG	
7	0.2400	43.04	9.98	53.02	62.10	-9.08	QP	
8	0.2400	29.30	9.98	39.28	52.10	-12.82	AVG	
9	0.2760	39.80	9.99	49.79	60.94	-11.15	QP	
10	0.2760	27.40	9.99	37.39	50.94	-13.55	AVG	
11	0.4470	33.19	10.09	43.28	56.93	-13.65	QP	
12	0.4470	21.10	10.09	31.19	46.93	-15.74	AVG	

Test Voltage	AC 110V/60Hz	Phase	Line
Test Mode	Mode 1		

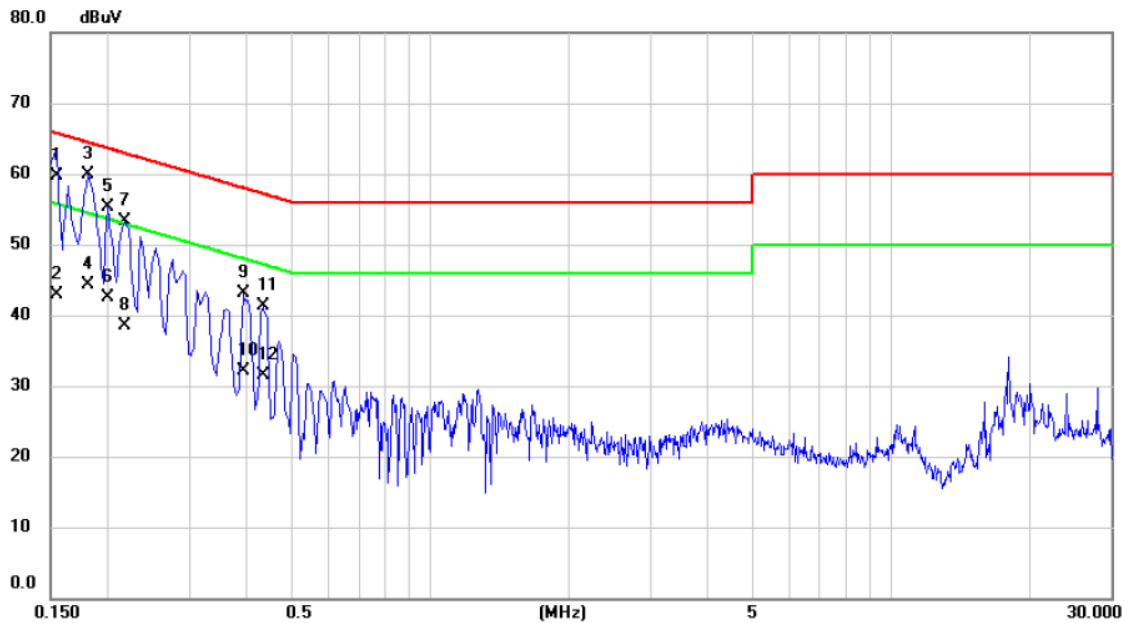

No.	Mk.	Freq. MHz	Reading Level dBuV	Correct Factor dB	Measure- ment dBuV	Limit dBuV	Margin dB	Detector	Comment
1		0.1545	50.10	9.70	59.80	65.75	-5.95	QP	
2		0.1545	33.30	9.70	43.00	55.75	-12.75	AVG	
3	*	0.1815	49.99	9.85	59.84	64.42	-4.58	QP	
4		0.1815	34.50	9.85	44.35	54.42	-10.07	AVG	
5		0.1995	45.41	9.91	55.32	63.63	-8.31	QP	
6		0.1995	32.60	9.91	42.51	53.63	-11.12	AVG	
7		0.2175	43.39	9.90	53.29	62.91	-9.62	QP	
8		0.2175	28.70	9.90	38.60	52.91	-14.31	AVG	
9		0.3930	33.18	9.90	43.08	58.00	-14.92	QP	
10		0.3930	22.30	9.90	32.20	48.00	-15.80	AVG	
11		0.4335	31.33	9.91	41.24	57.19	-15.95	QP	
12		0.4335	21.60	9.91	31.51	47.19	-15.68	AVG	

Test Voltage	AC 110V/60Hz	Phase	Neutral
Test Mode	Mode 1		

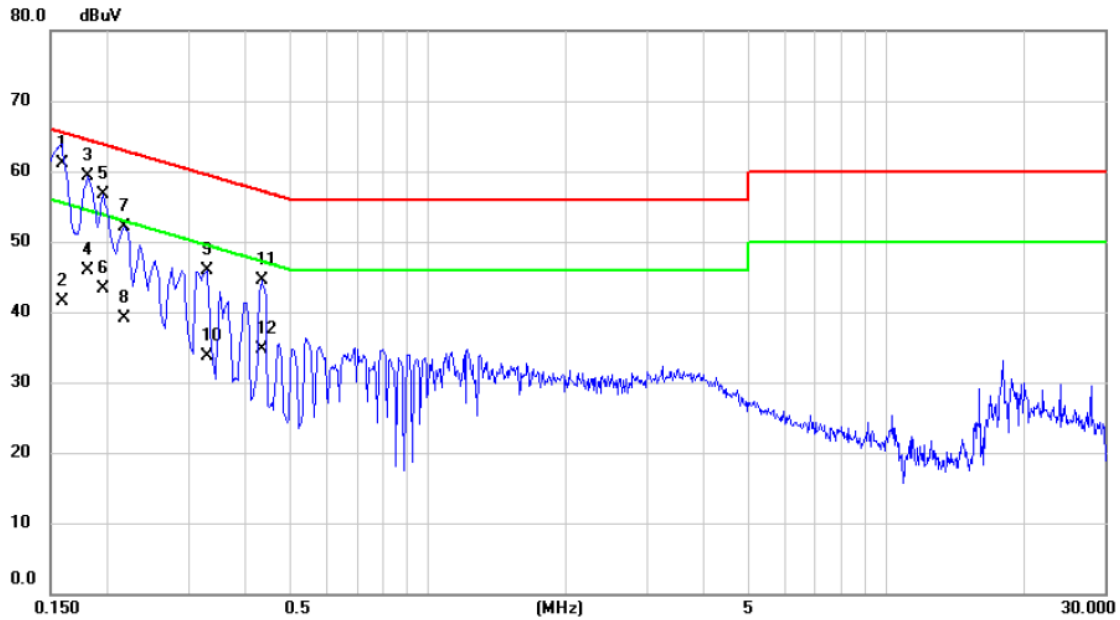

No.	Mk.	Freq. MHz	Reading Level dBuV	Correct Factor dB	Measure- ment dBuV	Limit dBuV	Margin dB	Detector	Comment
1	*	0.1590	51.30	9.81	61.11	65.52	-4.41	QP	
2		0.1590	31.70	9.81	41.51	55.52	-14.01	AVG	
3		0.1815	49.29	9.94	59.23	64.42	-5.19	QP	
4		0.1815	35.90	9.94	45.84	54.42	-8.58	AVG	
5		0.1950	46.77	9.99	56.76	63.82	-7.06	QP	
6		0.1950	33.40	9.99	43.39	53.82	-10.43	AVG	
7		0.2175	42.14	10.00	52.14	62.91	-10.77	QP	
8		0.2175	29.20	10.00	39.20	52.91	-13.71	AVG	
9		0.3300	35.85	10.02	45.87	59.45	-13.58	QP	
10		0.3300	23.70	10.02	33.72	49.45	-15.73	AVG	
11		0.4335	34.34	10.08	44.42	57.19	-12.77	QP	
12		0.4335	24.60	10.08	34.68	47.19	-12.51	AVG	

4. EMC EMISSION TEST- EN 55032:2015+AC:2016

4.1 RADIATED EMISSIONS UP TO 1 GHZ

4.1.1 LIMITS

Class B equipment up to 1000MHz

Frequency Range MHz	Measurement			Class B limits dB(μ V/m)
	Facility	Distance m	Detector type/ bandwidth	
30 - 230	SAC	10	Quasi peak / 120 kHz	30
230 - 1000				37

Notes:

- (1) The limit for radiated test was performed according to as following: EN 55032
- (2) The tighter limit applies at the band edges.
- (3) Emission level (dBuV/m)=20log Emission level (uV/m).
- (4) The test result calculated as following:
 Measurement Value = Reading Level + Correct Factor
 Correct Factor = Antenna Factor + Cable Loss - Amplifier Gain(if use)
 Margin Level = Measurement Value - Limit Value

4.1.2 MEASUREMENT INSTRUMENTS LIST

Item	Kind of Equipment	Manufacturer	Type No.	Series Model	Calibrated until
1	Receiver	Keysight	N9038A	MY54450004	Jul. 25, 2021
2	MXE EMI Receiver	Agilent	N9038A	MY53220133	Feb. 28, 2021
3	Pre-Amplifier	EMC INSTRUMENT	EMC 9135	980284	Mar. 01, 2021
4	Pre-Amplifier	EMC INSTRUMENT	EMC 9135	980283	Mar. 01, 2021
5	Trilog-Broadband Antenna	Schwarzbeck	VULB9168	946	Oct. 16, 2021
6	Trilog-Broadband Antenna	Schwarzbeck	VULB9168	947	Nov. 09, 2021
7	Cable	emci	LMR-400 (5m+11m+8m)	N/A	Oct. 19, 2021
8	Cable	emci	LMR-400 (5m+8m+8m)	N/A	Oct. 20, 2021
9	Measurement Software	Farad	EZ-EMC Ver.BTL-2ANT-1	N/A	N/A
10	Multi-Device Controller	ETS-Lindgren	2090	N/A	N/A
11	Attenuator	EMCI	EMCI-N-6-06	N0670	Nov. 09, 2021
12	Attenuator	EMCI	EMCI-N-6-06	N0671	Oct. 16, 2021

Remark: "N/A" denotes no model no., no serial no. or no calibration specified.

All calibration period of equipment list is one year.

4.1.3 TEST PROCEDURE

- a. The measuring distance of 10 m shall be used for measurements. The EUT was placed on the top of a rotating table 0.8 meter above the ground at a 10 meter semi-anechoic chamber. The table was rotated 360 degrees to determine the position of the highest radiation.(below 1GHz).
- b. The height of the equipment or of the substitution antenna shall be 0.8 m, the height of the test antenna shall vary between 1 m to 4 m. Both horizontal and vertical polarizations of the antenna are set to make the measurement.
- c. The initial step in collecting radiated emission data is a receiver peak detector mode pre-scanning the measurement frequency range. Significant peaks are then marked and then Quasi Peak detector mode re-measured.
- d. All readings are Peak unless otherwise stated QP in column of Note. Peak denotes that the Peak reading compliance with the QP Limits and then QP Mode measurement didn't perform. (below 1GHz)
- e. For the actual test configuration, please refer to the related Item - Block Diagram of system tested.

4.1.4 DEVIATION FROM TEST STANDARD

No deviation

4.1.5 TEST SETUP

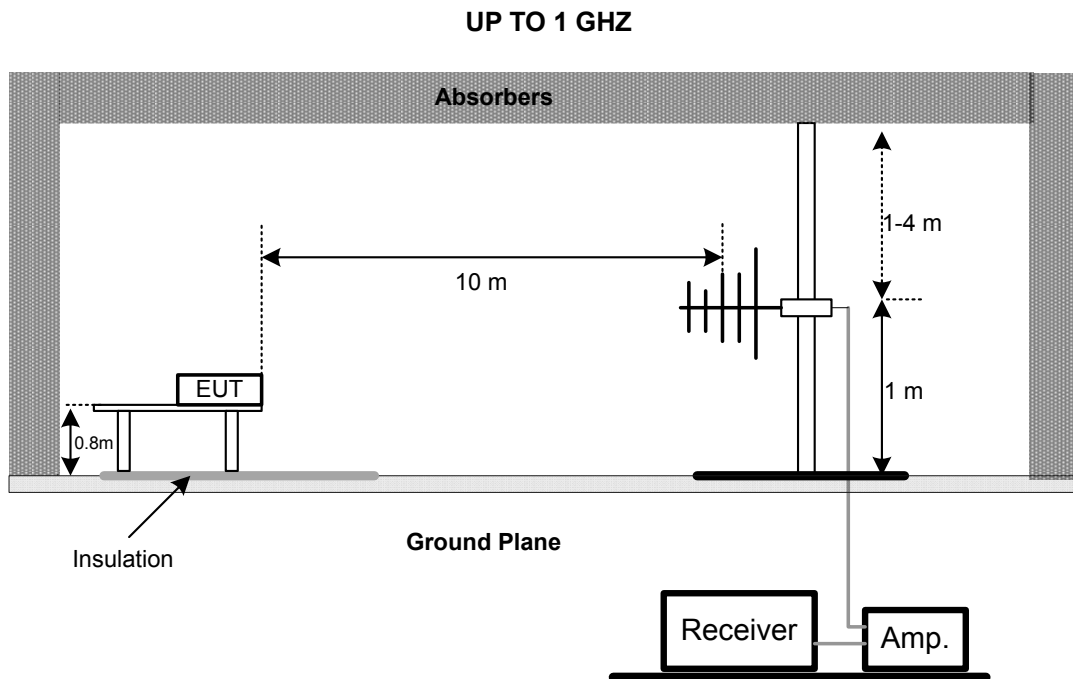

Note: The antenna can be moved between 1 to 4 meters above the ground.

4.1.6 MEASUREMENT DISTANCE

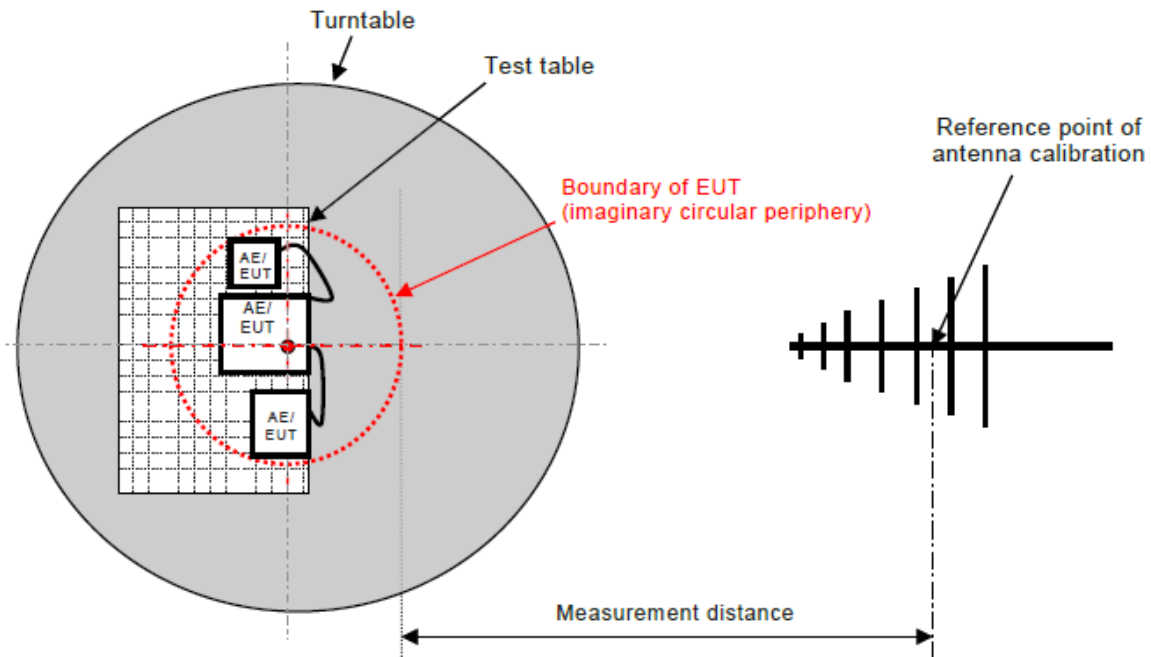

IEC

Figure C.1 – Measurement distance

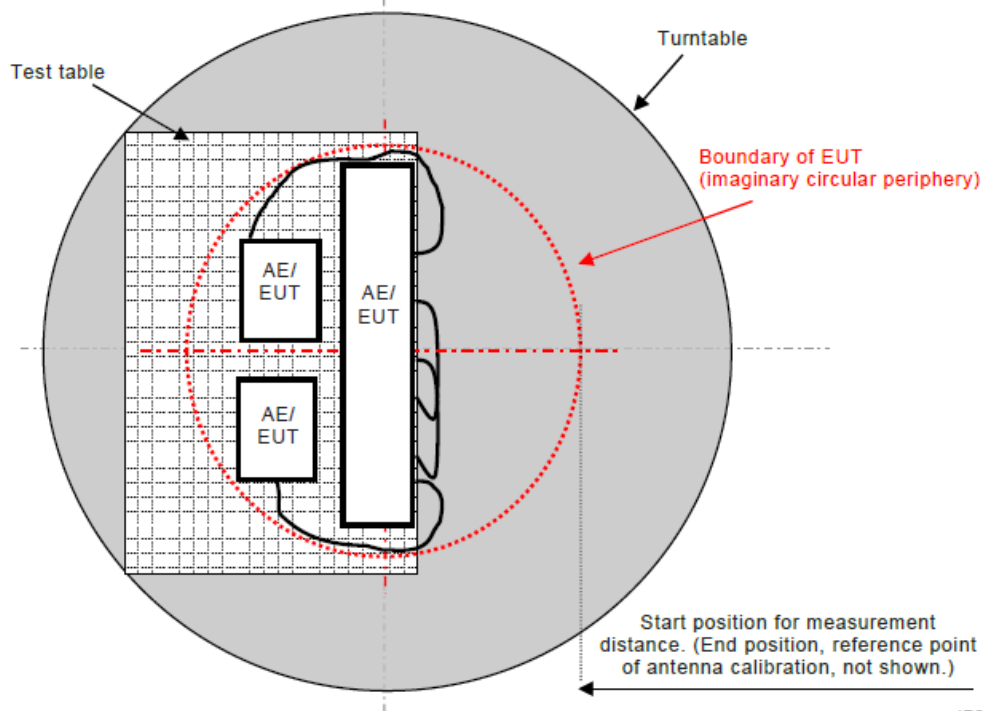

IEC

Figure C.2 – Boundary of EUT, Local AE and associated cabling

4.1.7 TEST RESULTS (UP TO 1 GHZ)

Test Voltage	AC 230V/50Hz	Polarization	Vertical
Test Mode	Mode 1		

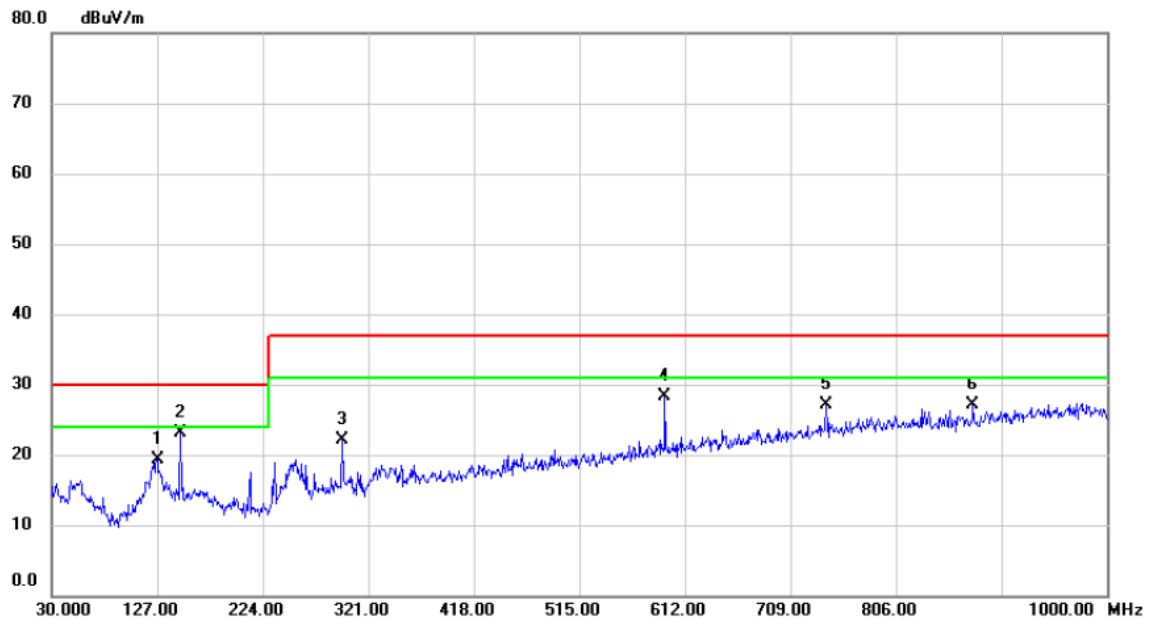

No.	Mk.	Freq. MHz	Reading Level dBuV	Correct Factor dB	Measure- ment dBuV/m	Limit dBuV/m	Margin dB	Detector	Comment
1		127.0000	38.44	-19.06	19.38	30.00	-10.62	QP	
2	*	148.3400	40.22	-17.03	23.19	30.00	-6.81	QP	
3		296.7500	37.58	-15.47	22.11	37.00	-14.89	QP	
4		593.5700	37.34	-9.07	28.27	37.00	-8.73	QP	
5		741.9800	34.48	-7.32	27.16	37.00	-9.84	QP	
6		876.8100	33.66	-6.62	27.04	37.00	-9.96	QP	

Test Voltage	AC 230V/50Hz	Polarization	Horizontal
Test Mode	Mode 1		

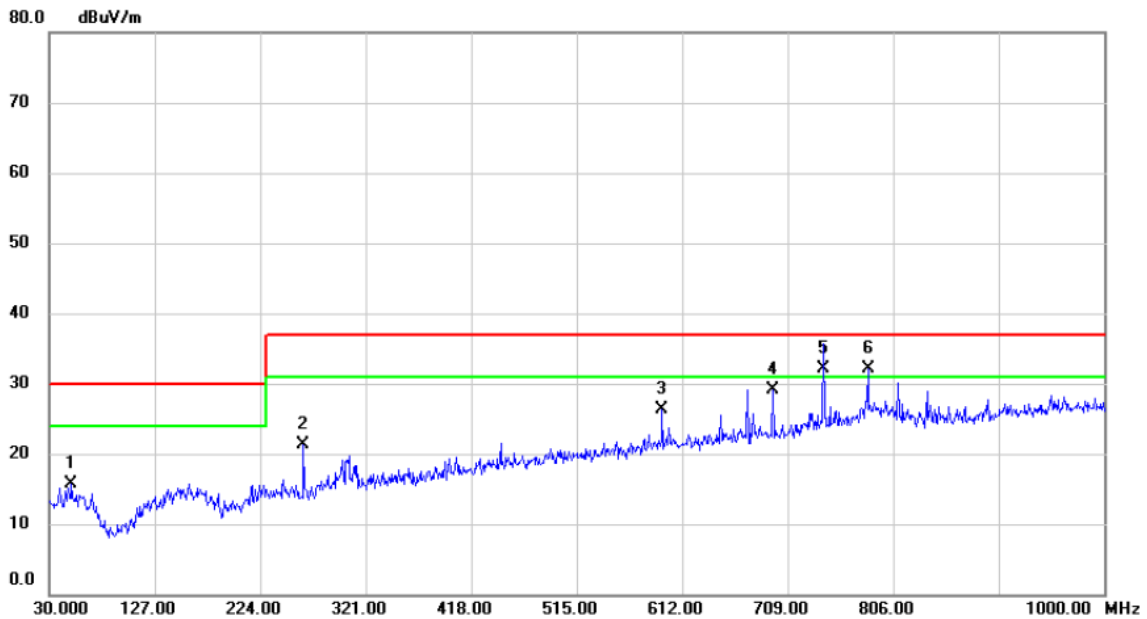

No. Mk.	Freq. MHz	Reading Level dBuV	Correct Factor dB	Measure- ment dBuV/m	Limit dBuV/m	Margin dB	Detector	Comment
1	50.3700	33.33	-17.68	15.65	30.00	-14.35	QP	
2	263.7700	37.86	-16.59	21.27	37.00	-15.73	QP	
3	593.5700	35.06	-8.84	26.22	37.00	-10.78	QP	
4	695.4200	37.05	-7.85	29.20	37.00	-7.80	QP	
5 !	741.9800	39.20	-7.10	32.10	37.00	-4.90	QP	
6 *	782.7200	38.84	-6.65	32.19	37.00	-4.81	QP	

4.2 RADIATED EMISSIONS ABOVE 1 GHZ

4.2.1 LIMITS

Class B equipment above 1000MHz

Frequency Range MHz	Measurement			Class B limits dB(μ V/m)
	Facility	Distance m	Detector type/bandwidth	
1000 - 3000	FSOATS	3	Average / 1 MHz	50
3000 - 6000				54
1000 - 3000			Peak / 1 MHz	70
3000 - 6000				74

Notes:

- (1) The limit for radiated test was performed according to as following: EN 55032
- (2) The tighter limit applies at the band edges.
- (3) Emission level (dBuV/m)=20log Emission level (uV/m).
- (4) The test result calculated as following:
 Measurement Value = Reading Level + Correct Factor
 Correct Factor = Antenna Factor + Cable Loss - Amplifier Gain(if use)
 Margin Level = Measurement Value - Limit Value

Required highest frequency for radiated measurement

Highest internal frequency (F_x) MHz	Highest measured frequency MHz
$F_x \leq 108$	1000
$108 < F_x \leq 500$	2000
$500 < F_x \leq 1000$	5000
$F_x > 1000$	5 th up to a maximum 6 GHz,

Note for FM and TV broadcast receiver, F_x is determined from the highest frequency generated or used excluding the local oscillator and tuned frequencies.

4.2.1 MEASUREMENT INSTRUMENTS LIST

Item	Kind of Equipment	Manufacturer	Type No.	Series Model	Calibrated until
1	Horn Antenna	EMCO	3115	9605-4803	May 12, 2021
2	Amplifier	Agilent	8449B	3008A02333	Mar. 01, 2021
3	MXE EMI Receiver	Agilent	N9038A	MY53220133	Feb. 28, 2021
4	Measurement Software	Farad	EZ-EMC Ver.BTL-2ANT-1	N/A	N/A
5	Multi-Device Controller	ETS-Lindgren	2090	N/A	N/A
6	Controller	MF	MF-7802	MF780208159	N/A
7	Cable	Mlcable Inc.	B10-01-01-5M	18047123	Feb. 28, 2021
8	Cable	Mlcable Inc.	B10-01-01-12M	18072743	Feb. 28, 2021
9	Cable	RegalWay	RWLPS50-7.9A- SMSM-1M	20200102 001	Feb. 28, 2021

Remark: "N/A" denotes no model no., no serial no. or no calibration specified.

All calibration period of equipment list is one year.

4.2.1.1 TEST PROCEDURE

- The measuring distance of 3 m shall be used for measurements. The EUT was placed on the top of a rotating table 0.8 meter above the ground at a 10 meter semi-anechoic chamber. The table was rotated 360 degrees to determine the position of the highest radiation.
- The height of the equipment or of the substitution antenna shall be 0.8 m, the height of the test antenna shall vary between 1 m to 4 m. Both horizontal and vertical polarizations of the antenna are set to make the measurement.
- The initial step in collecting radiated emission data is a receiver peak detector mode pre-scanning the measurement frequency range. Significant peaks are then marked and then Quasi Peak detector mode re-measured.
- All readings are Peak Mode value unless otherwise stated AVG in column of Note. If the Peak Mode Measured value compliance with the Peak Limits and lower than AVG Limits, the EUT shall be deemed to meet both Peak & AVG Limits and then only Peak Mode was measured, but AVG Mode didn't perform. (above 1GHz)
- For the actual test configuration, please refer to the related Item - Block Diagram of system tested.

4.2.1.2 DEVIATION FROM TEST STANDARD

No deviation

4.2.1.3 TEST SETUP

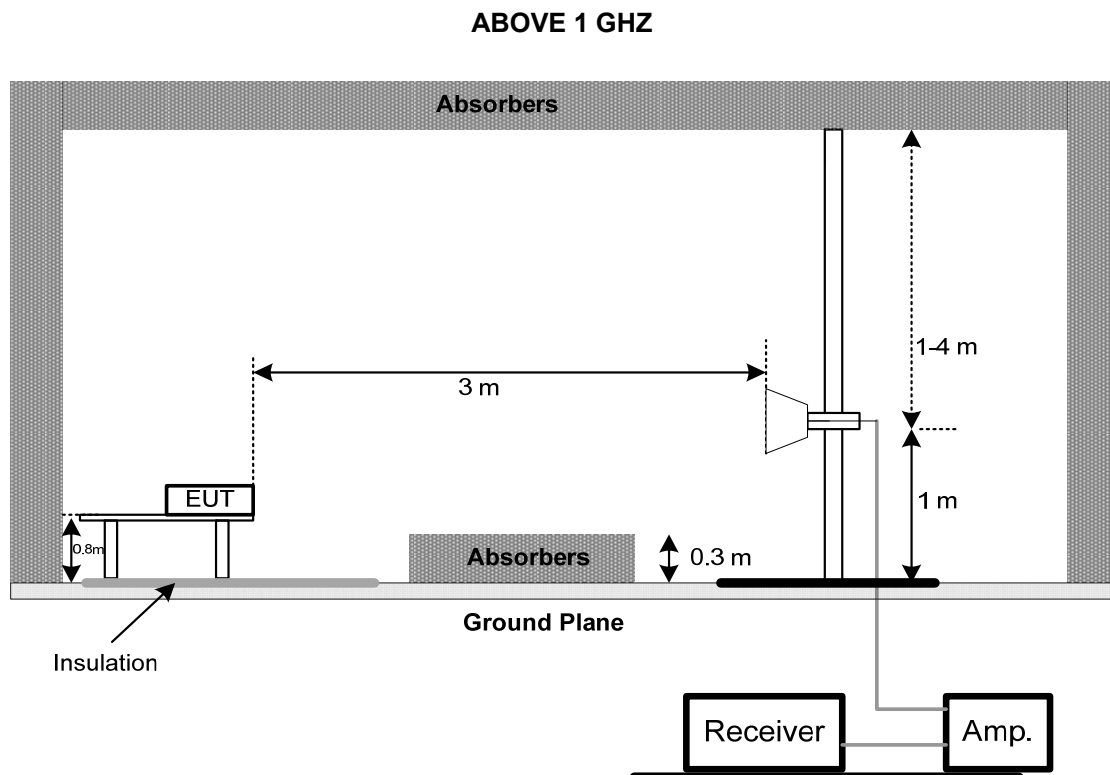

4.2.1.4 MEASUREMENT DISTANCE

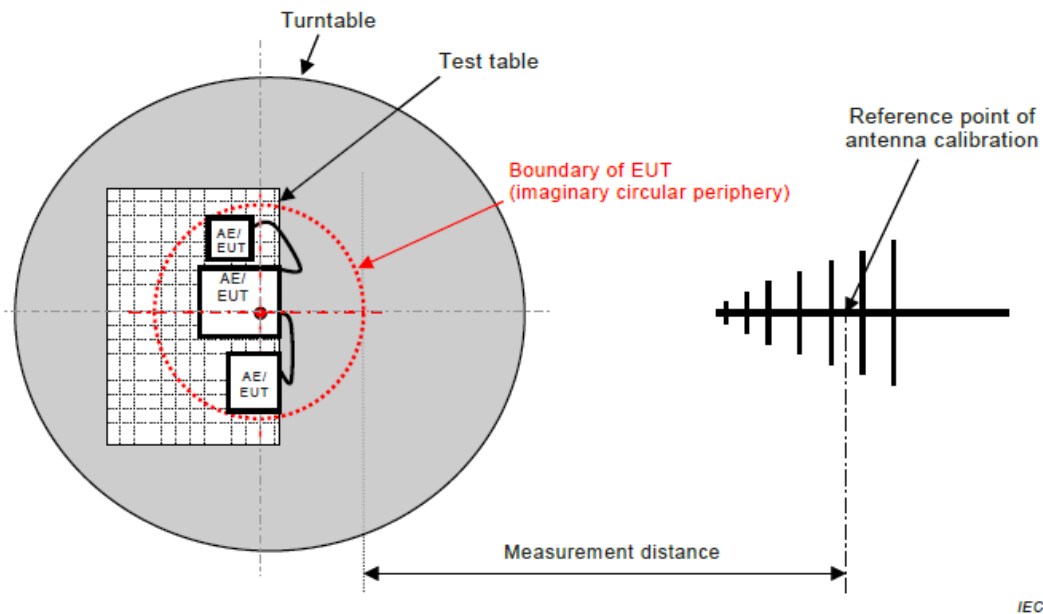

Figure C.1 – Measurement distance

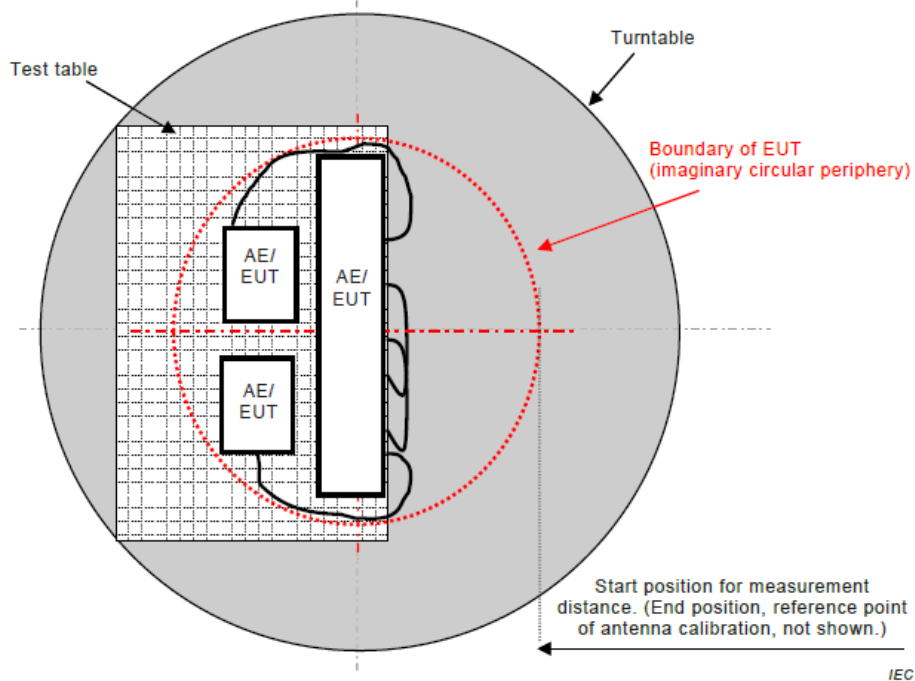
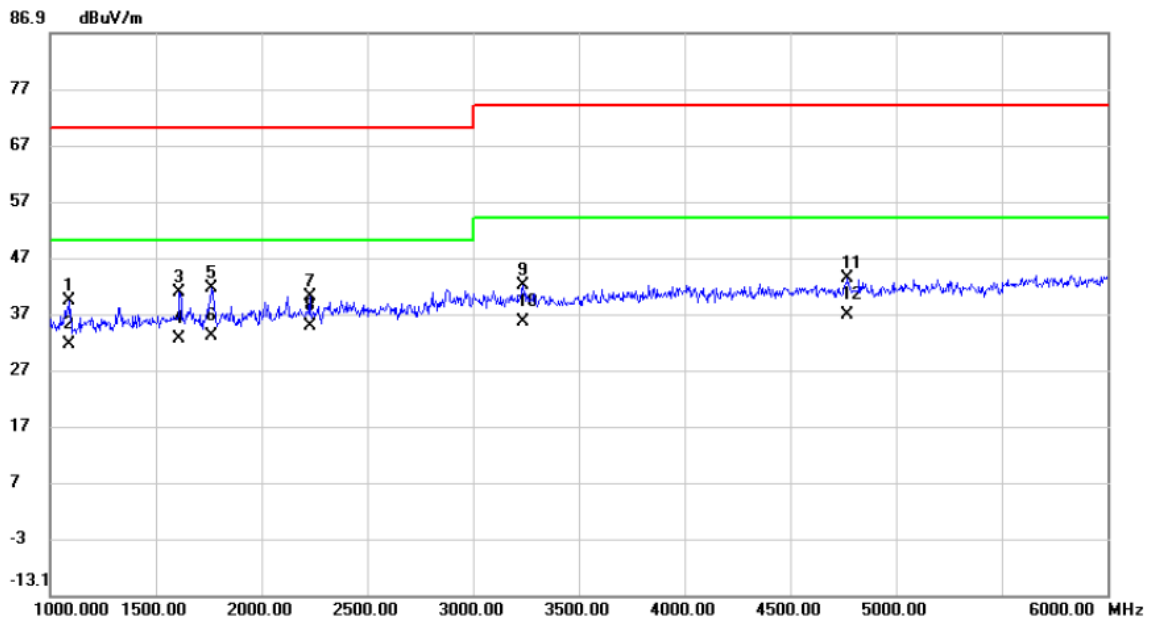

Figure C.2 – Boundary of EUT, Local AE and associated cabling

4.2.1.5 TEST RESULTS (ABOVE 1 GHZ)

Test Voltage	AC 230V/50Hz	Polarization	Vertical
Test Mode	Mode 1		



No.	Mk.	Freq. MHz	Reading Level dBuV	Correct Factor dB	Measure- ment dBuV/m	Limit dBuV/m	Margin dB	Detector	Comment
1		1090.000	43.95	-4.75	39.20	70.00	-30.80	peak	
2		1090.000	36.23	-4.75	31.48	50.00	-18.52	AVG	
3		1612.500	43.03	-2.26	40.77	70.00	-29.23	peak	
4		1612.500	34.77	-2.26	32.51	50.00	-17.49	AVG	
5		1760.000	42.89	-1.32	41.57	70.00	-28.43	peak	
6		1760.000	34.38	-1.32	33.06	50.00	-16.94	AVG	
7		2227.500	39.05	1.04	40.09	70.00	-29.91	peak	
8	*	2227.500	33.71	1.04	34.75	50.00	-15.25	AVG	
9		3235.000	37.06	5.09	42.15	74.00	-31.85	peak	
10		3235.000	30.53	5.09	35.62	54.00	-18.38	AVG	
11		4770.000	33.48	9.68	43.16	74.00	-30.84	peak	
12		4770.000	27.11	9.68	36.79	54.00	-17.21	AVG	

Test Voltage	AC 230V/50Hz	Polarization	Horizontal
Test Mode	Mode 1		

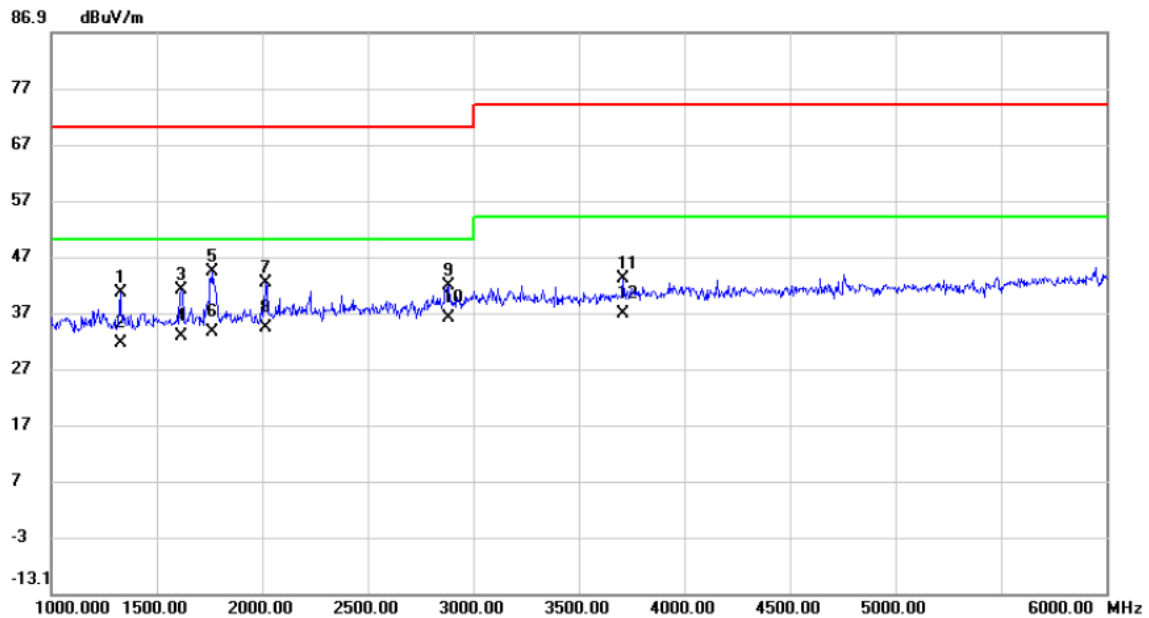

No.	Mk.	Freq. MHz	Reading Level dBuV	Correct Factor dB	Measure- ment dBuV/m	Limit dBuV/m	Margin dB	Detector	Comment
1		1327.500	44.31	-3.74	40.57	70.00	-29.43	peak	
2		1327.500	35.31	-3.74	31.57	50.00	-18.43	AVG	
3		1615.000	43.20	-2.25	40.95	70.00	-29.05	peak	
4		1615.000	34.93	-2.25	32.68	50.00	-17.32	AVG	
5		1760.000	45.63	-1.32	44.31	70.00	-25.69	peak	
6		1760.000	34.77	-1.32	33.45	50.00	-16.55	AVG	
7		2015.000	41.93	0.28	42.21	70.00	-27.79	peak	
8		2015.000	33.90	0.28	34.18	50.00	-15.82	AVG	
9		2880.000	37.86	3.81	41.67	70.00	-28.33	peak	
10	*	2880.000	32.15	3.81	35.96	50.00	-14.04	AVG	
11		3712.500	36.03	6.90	42.93	74.00	-31.07	peak	
12		3712.500	29.93	6.90	36.83	54.00	-17.17	AVG	

4.3 CONDUCTED EMISSION MEASUREMENT AT AC MAINS POWER PORTS

4.3.1 LIMITS

Requirements for conducted emissions from AC mains power ports of Class B equipment

Frequency Range MHz	Coupling Device	Detector Type / bandwidth	Class B Limits (dB(μV))
0.15 - 0.5	AMN	Quasi Peak / 9 kHz	66-56
0.5 - 5			56
5 - 30			60
0.15 - 0.5	AMN	Average / 9 kHz	56-46
0.5 - 5			46
5 - 30			50

NOTE:

(1) The test result calculated as following:

Measurement Value = Reading Level + Correct Factor

Correct Factor = Insertion Loss + Cable Loss + Attenuator Factor(if use)

Margin Level = Measurement Value – Limit Value

4.3.2 MEASUREMENT INSTRUMENTS LIST

Item	Kind of Equipment	Manufacturer	Type No.	Series Model	Calibrated until
1	50Ω Terminator	SHX	TF2-3G-A	8122901	Feb. 28, 2021
2	TWO-LINE V-NETWORK	R&S	ENV216	100526	Mar. 01, 2021
3	EMI Test Receiver	R&S	ESR3	101862	Jul. 25, 2021
4	Artificial-Mains Network	SCHWARZBECK	NSLK 8127	8127685	Mar. 01, 2021
5	Cable	N/A	RG400	N/A(12m)	Mar. 10, 2021
6	Measurement Software	Farad	EZ-EMC Ver.NB-03A1-01	N/A	N/A

Remark: "N/A" denotes no model name, serial no. or calibration specified.

All calibration period of equipment list is one year.

4.3.3 TEST PROCEDURE

- The EUT was placed 0.8 meters from the horizontal ground plane with EUT being connected to the power mains through a line impedance stabilization network (LISN). All other support equipments powered from additional LISN(s). The LISN provide 50 Ohm/ 50uH of coupling impedance for the measuring instrument.
- Interconnecting cables that hang closer than 40 cm to the ground plane shall be folded back and forth in the center forming a bundle 30 to 40 cm long.
- I/O cables that are not connected to a peripheral shall be bundled in the center. The end of the cable may be terminated, if required, using the correct terminating impedance. The overall length shall not exceed 1 m.
- LISN at least 80 cm from nearest part of EUT chassis.
- For the actual test configuration, please refer to the related Item –EUT Test Photos.

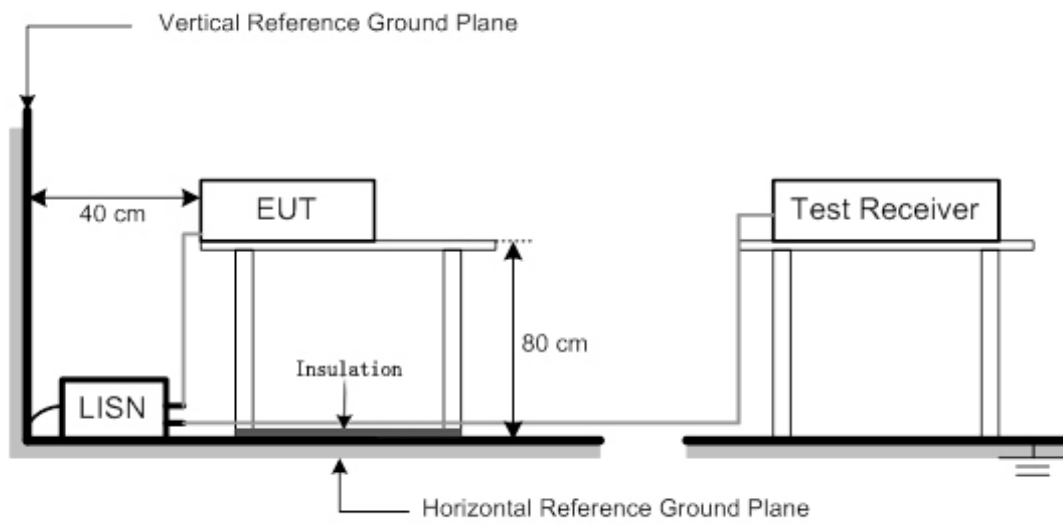
4.3.4 TEST SETUP

4.3.5 TEST RESULTS

Test Voltage	AC 230V/50Hz	Phase	Line
Test Mode	Mode 1		

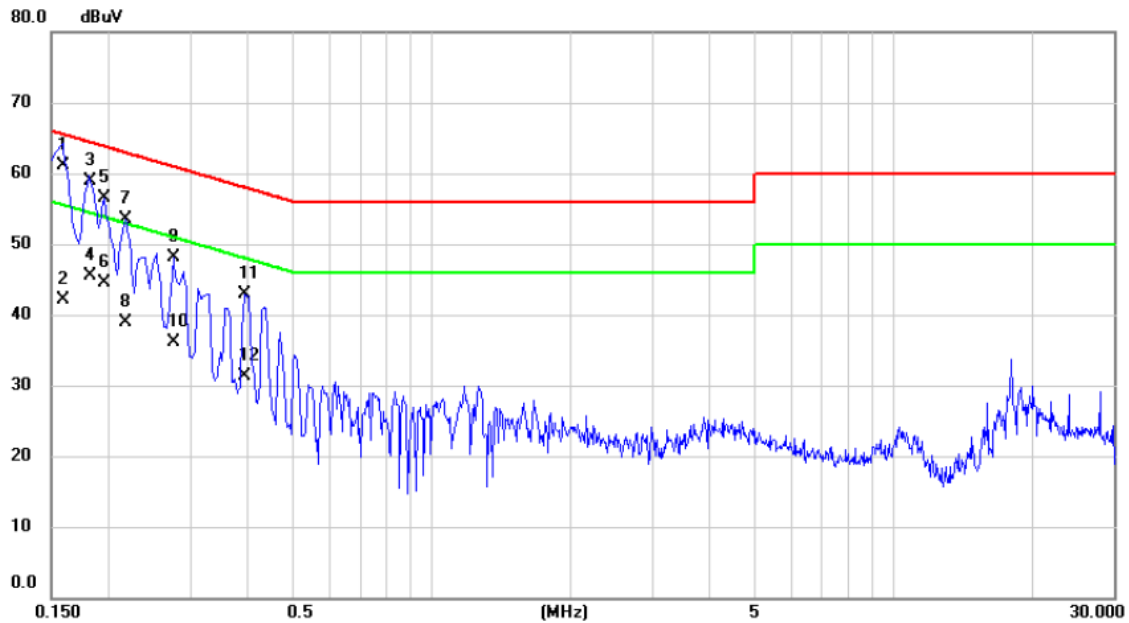

No. Mk.	Freq. MHz	Reading Level dBuV	Correct Factor dB	Measure- ment dBuV	Limit dBuV	Margin dB	Detector	Comment
1 *	0.1590	51.40	9.73	61.13	65.52	-4.39	QP	
2	0.1590	32.30	9.73	42.03	55.52	-13.49	AVG	
3	0.1825	49.13	9.85	58.98	64.37	-5.39	QP	
4	0.1825	35.60	9.85	45.45	54.37	-8.92	AVG	
5	0.1950	46.59	9.90	56.49	63.82	-7.33	QP	
6	0.1950	34.70	9.90	44.60	53.82	-9.22	AVG	
7	0.2175	43.56	9.90	53.46	62.91	-9.45	QP	
8	0.2175	29.10	9.90	39.00	52.91	-13.91	AVG	
9	0.2760	38.15	9.88	48.03	60.94	-12.91	QP	
10	0.2760	26.20	9.88	36.08	50.94	-14.86	AVG	
11	0.3930	33.01	9.90	42.91	58.00	-15.09	QP	
12	0.3930	21.40	9.90	31.30	48.00	-16.70	AVG	

Test Voltage	AC 230V/50Hz	Phase	Neutral
Test Mode	Mode 1		

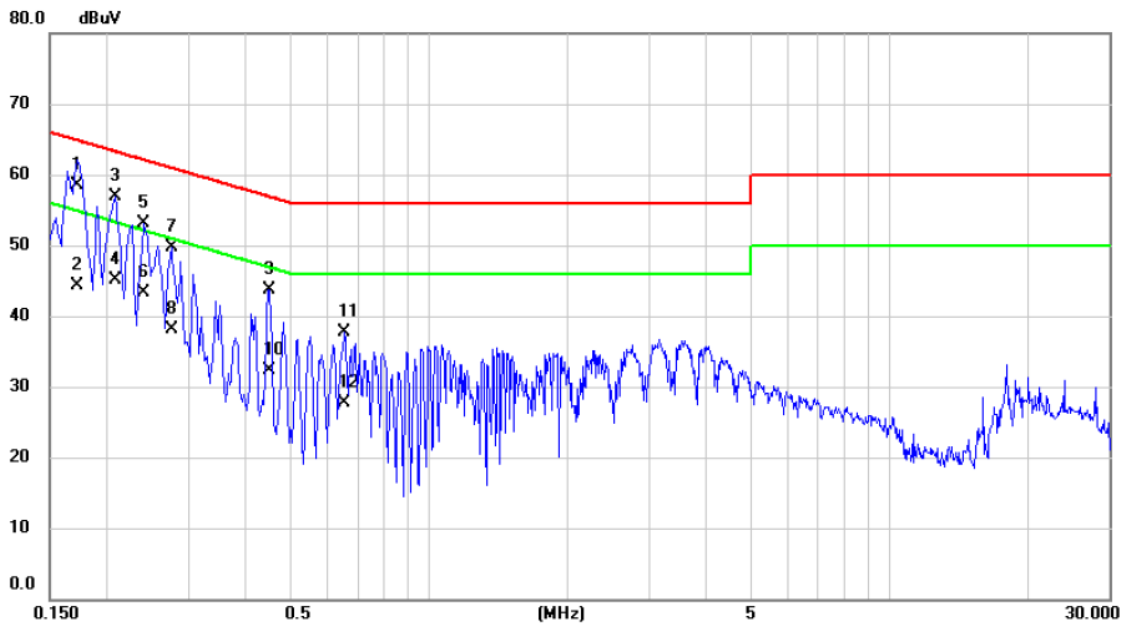

No.	Mk.	Freq. MHz	Reading Level dBuV	Correct Factor dB	Measure- ment dBuV	Limit dBuV	Margin dB	Detector	Comment
1	*	0.1725	48.60	9.91	58.51	64.84	-6.33	QP	
2		0.1725	34.30	9.91	44.21	54.84	-10.63	AVG	
3		0.2085	46.82	10.00	56.82	63.26	-6.44	QP	
4		0.2085	35.20	10.00	45.20	53.26	-8.06	AVG	
5		0.2400	43.14	9.98	53.12	62.10	-8.98	QP	
6		0.2400	33.30	9.98	43.28	52.10	-8.82	AVG	
7		0.2760	39.69	9.99	49.68	60.94	-11.26	QP	
8		0.2760	28.10	9.99	38.09	50.94	-12.85	AVG	
9		0.4515	33.59	10.10	43.69	56.85	-13.16	QP	
10		0.4515	22.30	10.10	32.40	46.85	-14.45	AVG	
11		0.6540	27.55	10.13	37.68	56.00	-18.32	QP	
12		0.6540	17.60	10.13	27.73	46.00	-18.27	AVG	

5. HARMONIC AND FLICKER TEST

5.1 HARMONIC CURRENT EMISSIONS

5.1.1 LIMITS

The power consumption is less than 75W, there is no limit applied.

5.1.2 MEASUREMENT INSTRUMENTS LIST

Item	Kind of Equipment	Manufacturer	Type No.	Series Model	Calibrated until
1	Harmonics and Flicker Analyzer	California Instruments	PACS-1	72344	Jul. 25, 2021
2	3KVA AC Power source	California Instruments	3001ix	56309	Jul. 25, 2021
3	Measurement Software	California	CTS4.0 Version 4.23	N/A	N/A

Remark: "N/A" denotes no model no., no serial No. or no calibration specified.

All calibration period of equipment list is one year.

5.1.3 TEST PROCEDURE

- The EUT was placed on the top of a wooden table 0.8 meters above the ground and operated to produce the maximum harmonic components under normal operating conditions.
- The correspondent test program of test instrument to measure the current harmonics emanated from EUT is chosen. The measure time shall be not less than the time necessary for the EUT to be exercised.

5.1.4 DEVIATION FROM TEST STANDARD

No deviation

5.1.5 TEST SETUP

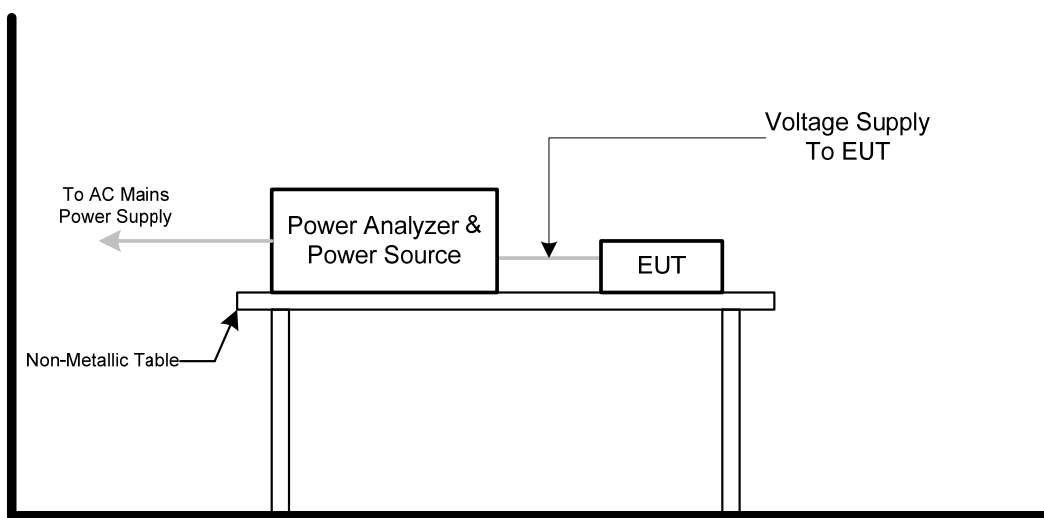

5.1.6 TEST RESULTS

Harmonic - Class D	
Test Voltage	AC 230V/50Hz
Test Mode	Mode 1

Current & voltage waveforms

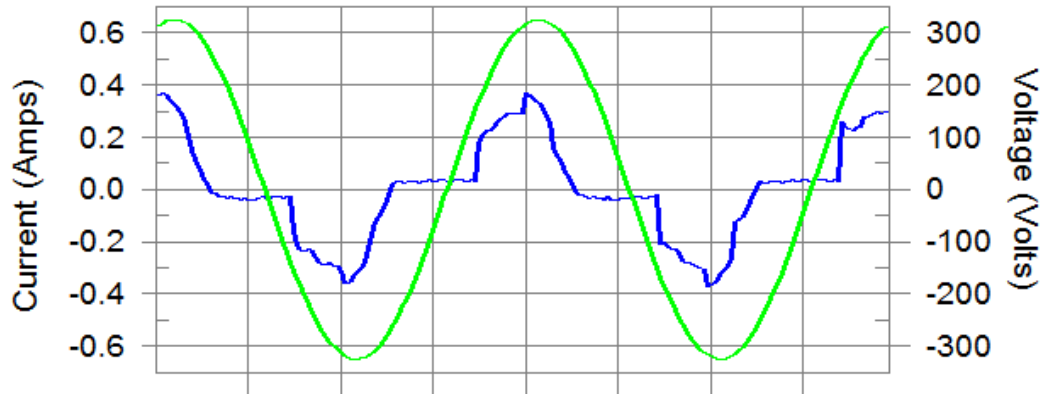

Harmonics and Class D limit line European Limits

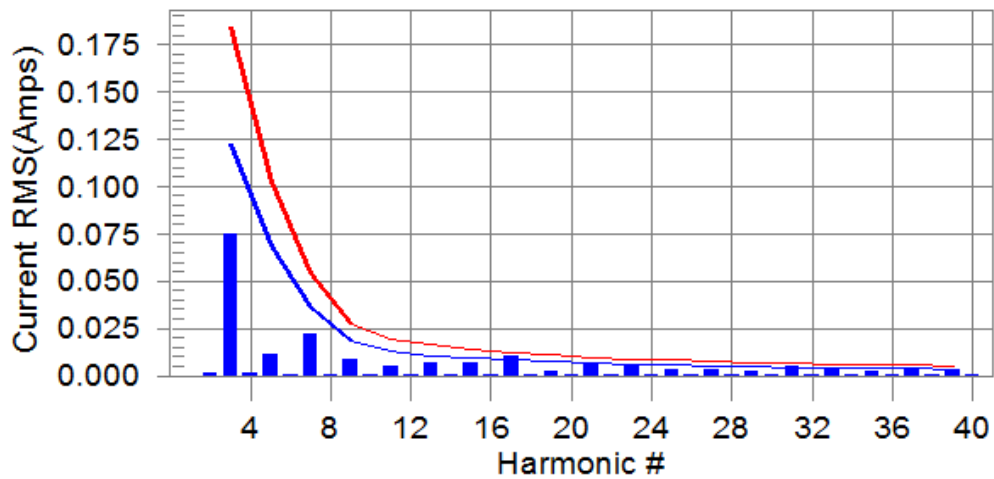

Test result: N/L Worst harmonics H0-0.0% of 150% limit, H0-0% of 100% limit

Current Test Result Summary (Run time)

Test Voltage	AC 230V/50Hz
Test Mode	Mode 1

Highest parameter values during test:

V _{RMS} (Volts):	229.92	Frequency(Hz):	50.00
I _{Peak} (Amps):	0.407	I _{RMS} (Amps):	0.192
I _{Fund} (Amps):	0.172	Crest Factor:	2.132
Power (Watts):	36.0	Power Factor:	0.823

Harm#	Harms(avg)	100%Limit	%of Limit	Harms(max)	150%Limit	%of Limit	Status
2	0.001	0.000	N/A	0.002	0.000	N/A	N/L
3	0.075	0.123	N/A	0.077	0.184	N/A	N/L
4	0.001	0.000	N/A	0.001	0.000	N/A	N/L
5	0.011	0.068	N/A	0.012	0.103	N/A	N/L
6	0.001	0.000	N/A	0.001	0.000	N/A	N/L
7	0.022	0.036	N/A	0.022	0.054	N/A	N/L
8	0.001	0.000	N/A	0.001	0.000	N/A	N/L
9	0.009	0.018	N/A	0.009	0.027	N/A	N/L
10	0.001	0.000	N/A	0.001	0.000	N/A	N/L
11	0.005	0.013	N/A	0.005	0.019	N/A	N/L
12	0.001	0.000	N/A	0.001	0.000	N/A	N/L
13	0.007	0.011	N/A	0.007	0.016	N/A	N/L
14	0.001	0.000	N/A	0.001	0.000	N/A	N/L
15	0.007	0.009	N/A	0.007	0.014	N/A	N/L
16	0.001	0.000	N/A	0.001	0.000	N/A	N/L
17	0.010	0.008	N/A	0.010	0.012	N/A	N/L
18	0.001	0.000	N/A	0.001	0.000	N/A	N/L
19	0.003	0.007	N/A	0.003	0.011	N/A	N/L
20	0.001	0.000	N/A	0.001	0.000	N/A	N/L
21	0.006	0.007	N/A	0.006	0.010	N/A	N/L
22	0.001	0.000	N/A	0.001	0.000	N/A	N/L
23	0.005	0.006	N/A	0.005	0.009	N/A	N/L
24	0.001	0.000	N/A	0.001	0.000	N/A	N/L
25	0.003	0.006	N/A	0.003	0.008	N/A	N/L
26	0.001	0.000	N/A	0.001	0.000	N/A	N/L
27	0.003	0.005	N/A	0.003	0.008	N/A	N/L
28	0.001	0.000	N/A	0.001	0.000	N/A	N/L
29	0.002	0.005	N/A	0.002	0.007	N/A	N/L
30	0.001	0.000	N/A	0.001	0.000	N/A	N/L
31	0.005	0.004	N/A	0.005	0.007	N/A	N/L
32	0.001	0.000	N/A	0.001	0.000	N/A	N/L
33	0.003	0.004	N/A	0.003	0.006	N/A	N/L
34	0.000	0.000	N/A	0.001	0.000	N/A	N/L
35	0.002	0.004	N/A	0.003	0.006	N/A	N/L
36	0.001	0.000	N/A	0.001	0.000	N/A	N/L
37	0.003	0.004	N/A	0.003	0.006	N/A	N/L
38	0.000	0.000	N/A	0.000	0.000	N/A	N/L
39	0.003	0.004	N/A	0.003	0.005	N/A	N/L
40	0.000	0.000	N/A	0.001	0.000	N/A	N/L

Note: The EUT power level is below 75.0 Watts and therefore has no defined limits

Voltage Source Verification Data (Run time)	
Test Voltage	AC 230V/50Hz
Test Mode	Mode 1

Highest parameter values during test:

Voltage (Vrms):	229.92	Frequency(Hz):	50.00
I_Peak (Amps):	0.407	I_RMS (Amps):	0.192
I_Fund (Amps):	0.172	Crest Factor:	2.132
Power (Watts):	36.0	Power Factor:	0.823

Harm#	Harmonics V-rms	Limit V-rms	% of Limit	Status
2	0.118	0.460	25.69	OK
3	0.534	2.069	25.82	OK
4	0.066	0.460	14.45	OK
5	0.055	0.920	5.98	OK
6	0.038	0.460	8.17	OK
7	0.043	0.690	6.23	OK
8	0.021	0.460	4.46	OK
9	0.038	0.460	8.36	OK
10	0.019	0.460	4.22	OK
11	0.014	0.230	6.03	OK
12	0.017	0.230	7.50	OK
13	0.021	0.230	9.02	OK
14	0.019	0.230	8.32	OK
15	0.014	0.230	6.16	OK
16	0.016	0.230	6.84	OK
17	0.019	0.230	8.38	OK
18	0.013	0.230	5.67	OK
19	0.011	0.230	4.63	OK
20	0.017	0.230	7.27	OK
21	0.011	0.230	4.68	OK
22	0.013	0.230	5.47	OK
23	0.010	0.230	4.33	OK
24	0.005	0.230	2.36	OK
25	0.008	0.230	3.55	OK
26	0.008	0.230	3.70	OK
27	0.008	0.230	3.37	OK
28	0.007	0.230	3.13	OK
29	0.009	0.230	4.08	OK
30	0.006	0.230	2.62	OK
31	0.010	0.230	4.29	OK
32	0.006	0.230	2.76	OK
33	0.008	0.230	3.28	OK
34	0.003	0.230	1.42	OK
35	0.004	0.230	1.57	OK
36	0.003	0.230	1.41	OK
37	0.006	0.230	2.45	OK
38	0.003	0.230	1.29	OK
39	0.007	0.230	2.99	OK
40	0.006	0.230	2.79	OK

5.2 VOLTAGE CHANGES, VOLTAGE FLUCTUATIONS AND FLICKER TEST

5.2.1 LIMITS

Tests	Limits	Descriptions
	EN 61000-3-3	
Pst	≤ 1.0 , $T_p= 10$ min.	Short Term Flicker Indicator
Plt	≤ 0.65 , $T_p=2$ hr.	Long Term Flicker Indicator
dc	$\leq 3.3\%$	Relative Steady-State V-Chang
dmax	$\leq 4\%$	Maximum Relative V-change
d (t)	≤ 500 ms	Relative V-change characteristic

5.2.2 MEASUREMENT INSTRUMENTS LIST

Item	Kind of Equipment	Manufacturer	Type No.	Series Model	Calibrated until
1	Harmonics and Flicker Analyzer	California Instruments	PACS-1	72344	Jul. 25, 2021
2	3KVA AC Power source	California Instruments	3001ix	56309	Jul. 25, 2021
3	Measurement Software	California	CTS4.0 Version 4.23	N/A	N/A

Remark: "N/A" denotes no model no., no serial No. or no calibration specified.

All calibration period of equipment list is one year.

5.2.3 TEST PROCEDURE

- a. Tests was performed according to the Test Conditions/Assessment of Voltage Fluctuations specified in EN 61000-3-3 depend on which standard adopted for compliance measurement.
- b. All types of harmonic current and/or voltage fluctuation in this report are assessed by direct measurement using flicker-meter.

5.2.4 DEVIATION FROM TEST STANDARD

No deviation

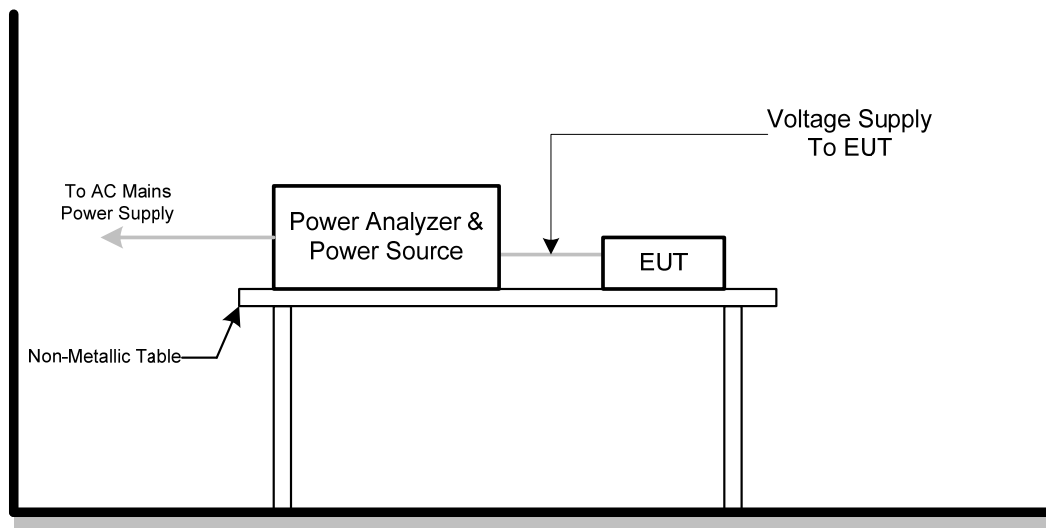
5.2.5 TEST SETUP

5.2.6 TEST RESULTS

Test Voltage	AC 230V/50Hz
Test Mode	Mode 1

Pst_i and limit line

European Limits

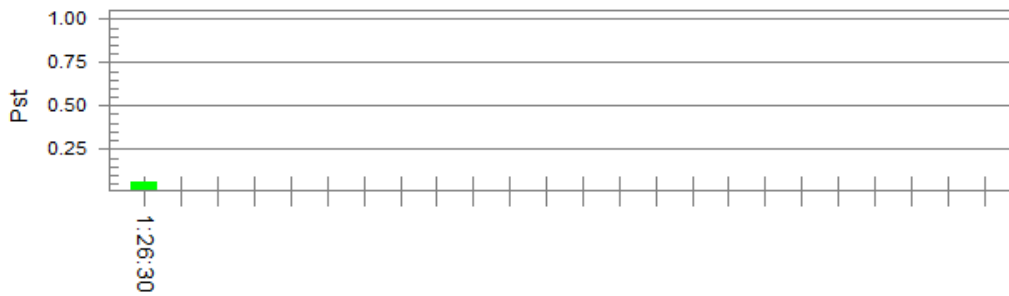

Plt and limit line

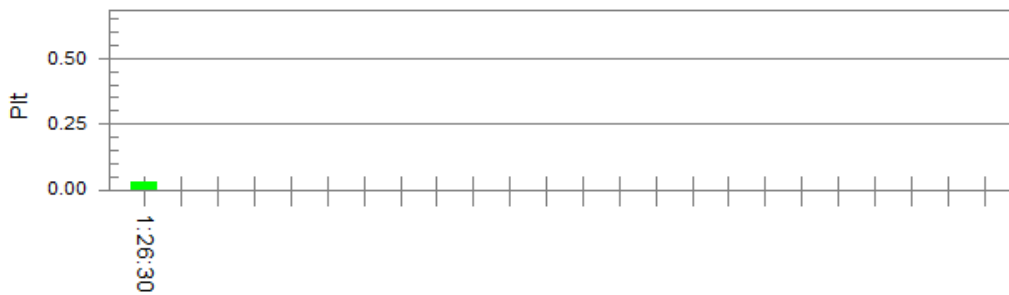

Parameter values recorded during the test:

Vrms at the end of test (Volt):	229.83		
T-max (mS):	0	Test limit (mS):	500.0 Pass
Highest dc (%):	0.00	Test limit (%):	3.30 Pass
Highest dmax (%):	0.00	Test limit (%):	4.00 Pass
Highest Pst (10 min. period):	0.064	Test limit:	1.000 Pass
Highest Plt (2 hr. period):	0.028	Test limit:	0.650 Pass

6. EMC IMMUNITY TEST

6.1 STANDARD COMPLIANCE/SEVERITY LEVEL/CRITERIA

Tests Standard No.	Test Specification Level / Test Mode	Test Ports	Criteria
Electrostatic discharge IEC 61000-4-2 (ESD)	±8kV air discharge ±4kV contact discharge (Direct Mode)	Enclosure	B
	±4kV HCP discharge ±4kV VCP discharge (Indirect Mode)	Enclosure	B
Continuous RF electromagnetic field disturbances,swept test IEC 61000-4-3 (RS)	80 MHz to 1000 MHz 3V/m(unmodulated, r.m.s), 1 kHz, 80%, AM modulated	Enclosure	A
Continuous RF electromagnetic field disturbances,spot test IEC 61000-4-3 (RS)	1800 MHz, 2600MHz, 3500 MHz, 5000MHz(±1 %) 3V/m(unmodulated, r.m.s), 1 kHz, 80%, AM modulated	Enclosure	A
Electrical fast transient/burst immunity IEC 61000-4-4 (EFT)	±0.5kV(peak) 5/50ns Tr/Th 5kHz Repetition Frequency (100kHz Repetition Frequency for xDSL port)	Analogue/digital data ports (NOTE 2)	B
	±0.5kV(peak) 5/50ns Tr/Th 5kHz Repetition Frequency	DC network power ports (NOTE 2)	B
	±1 kV(peak) 5/50ns Tr/Th 5kHz Repetition Frequency	AC mains power ports	B

Surge immunity IEC 61000-4-5 (Surge)	Port Type: unshielded symmetrical		
	Apply: lines to ground		
	Primary protection is Intended ±1 kV 10/700(5/320)Tr/Th µs	Analogue/digital data ports (NOTE 1) & (NOTE 2)	C
	Primary protection is not Intended ±1 kV 10/700(5/320) Tr/Th µs		C
	Port type: coaxial or shielded		
	Apply: shield to ground		
±0.5 kV 1.2/50(8/20) Tr/Th µs	Analogue/digital data ports (NOTE 1) & (NOTE 2)	B	
line to reference ground for each individual line: ±0.5 kV(peak) 1.2/50(8/20) Tr/Th µs	DC network power ports (NOTE 2)	B	
±1 kV(peak) 1.2/50(8/20) Tr/Th µs (line to line) ±2 kV(peak) 1.2/50(8/20) Tr/Th µs (line to earth or ground)	AC mains power ports	B	
Continuous induced RF disturbances IEC 61000-4-6 (CS)	0.15 MHz to 10 MHz 3V(unmodulated, r.m.s), 10 MHz to 30 MHz 3V to 1V(unmodulated, r.m.s), 30 MHz to 80 MHz 1V(unmodulated, r.m.s), 1kHz 80%, AM 150Ω source impedance	Analogue/digital data ports (NOTE 2)	A
	0.15 MHz to 10 MHz 3V(unmodulated, r.m.s), 10 MHz to 30 MHz 3V to 1V(unmodulated, r.m.s), 30 MHz to 80 MHz 1V(unmodulated, r.m.s), 1kHz 80%, AM 150Ω source impedance	DC network power ports (NOTE 2)	A
	0.15 MHz to 10 MHz 3V(unmodulated, r.m.s), 10 MHz to 30 MHz 3V to 1V(unmodulated, r.m.s), 30 MHz to 80 MHz 1V(unmodulated, r.m.s), 1kHz 80%, AM 150Ω source impedance	AC mains power ports	A

Power frequency magnetic field immunity IEC 61000-4-8 (PFMF)	50 Hz or 60Hz, 1A/m(r.m.s)	Enclosure	A
Voltage dips, short interruptions and voltage variations immunity IEC 61000-4-11 (Dips)	Voltage dips: Residual voltage < 5% 0.5 cycle Residual voltage < 70% 25 cycle(50Hz), 30 cycle (60Hz) Voltage interruptions: Residual voltage < 5% 250 cycle (50Hz), 300 cycle (60Hz)	AC Power Ports	B C C
Broadband impulse noise disturbances, repetitive (BIN-R)	0.15MHz to 0.5 MHz 107dBuV 0.5 MHz to 10 MHz 107dBuV to 36dBuV 10 MHz to 30 MHz 36dBuV to 30 dBuV	Analogue/digital data ports (Applicable only to CPE xDSL ports)	A
	0.70 ms 8.3 ms(for 60Hz) 10 ms(for 50Hz)	Analogue/digital data ports (Apply period based on the AC mains frequency)	A
Broadband impulse noise disturbances, isolated (BIN-I)	0.15MHz to 30 MHz 110dBuV	Analogue/digital data ports (Applicable only to CPE xDSL ports)	B
	0.24 ms 10 ms 300 ms	Analogue/digital data ports (Apply all burst durations)	B

Note.

- 1) Applicable only to ports which, according to the manufacturer's specification, may connect directly to outdoor cables.
- 2) Applicable only to ports which, according to the manufacturer's specification, support cable lengths greater than 3 m.

6.2 GENERAL PERFORMANCE CRITERIA

According to **EN55035** standard, the general performance criteria as following:

Criterion A	<p>The equipment shall continue to operate as intended without operator intervention. No degradation of performance, loss of function or change of operating state is allowed below a performance level specified by the manufacturer when the equipment is used as intended. The performance level may be replaced by a permissible loss of performance. If the minimum performance level or the permissible performance loss is not specified by the manufacturer, then either of these may be derived from the product description and documentation, and by what the user may reasonably expect from the equipment if used as intended.</p>
Criterion B	<p>During the application of the disturbance, degradation of performance is allowed. However, nonintended change of actual operating state or stored data is allowed to persist after the test.</p> <p>After the test, the equipment shall continue to operate as intended without operator intervention; no degradation of performance or loss of function is allowed, below a performance level specified by the manufacturer, when the equipment is used as intended. The performance level may be replaced by a permissible loss of performance. If the minimum performance level (or the permissible performance loss), or recovery time, is not specified by the manufacturer, then either of these may be derived from the product description and documentation, and by what the user may reasonably expect from the equipment if used as intended.</p>
Criterion C	<p>Loss of function is allowed, provided the function is self-recoverable, or can be restored by the operation of the controls by the user in accordance with the manufacturer's instructions. Areboot or re-start operation is allowed.</p> <p>Information stored in non-volatile memory, or protected by a battery backup, shall not be lost.</p>

6.3 ANNEX D (NORMATIVE) - DISPLAY AND DISPLAY OUTPUT FUNCTION

6.3.1 PERFORMANCE CRITERIA

Performance criterion A

for continuous radiated and conducted disturbances tests:

Apply criterion A as defined in GENERAL PERFORMANCE CRITERIA. Additionally, an increase in any degradation greater than just perceptible by observation of the image shall not occur as a consequence of the application of the test. Examples of such degradations are:

- superimposed patterning;
- positional disturbances due to synchronisation errors;
- geometric distortion;
- change of contrast or brightness;
- picture artefacts;
- freezing or disturbance of motion;
- image loss;
- video data or decoding errors.

Performance criterion A

for the power frequency magnetic field tests:

Alternative 1: A continuous magnetic field of 1 A/m:

The jitter (in mm) shall not exceed the value
$$\frac{(\text{character height in mm} + 0,3) \times 2,5}{33,3}$$

Performance criterion B:

Apply criterion B as defined in GENERAL PERFORMANCE CRITERIA.

Performance criterion C:

Apply criterion C as defined in GENERAL PERFORMANCE CRITERIA.

6.4 ANNEX G (NORMATIVE) - AUDIO OUTPUT FUNCTION

6.4.1 PERFORMANCE CRITERIA

Performance criterion A:

For devices that support telephony functions the limits of Table G.3 shall apply.

With respect to Table G.3:

- the interference ratio (electrical or acoustic) shall meet the limits in column 3; or,
- the acoustic level of the demodulated audio shall be less than the limits in column 4; or,
- the digitally coded level of demodulated audio shall be less than limits in column 5; or,
- the analogue level of the demodulated audio shall be less than the limits in column 6.

Table G.3 – Performance criterion A – Limits for devices supporting telephony

Type of immunity test	Frequency range MHz	Acoustic or electrical interference ratio	Equivalent direct measurement		
			dB (SPL)	Digital dBm0	Analogue dBm
Conducted	0,15 to 30	-20 dB	55	-50	-50
	30 to 80	-10 dB	65	-40	-40
Radiated	80 to 1000	0 dB	75	-30	-30

For terminals connected to digital wired network ports (such as Ethernet, ISDN), measurements of the demodulated 1 kHz may be performed on a remote AE, ideally of the same design.

For all other devices:

The measured acoustic interference ratio and/or the measured electrical interference ratio during the test shall be –20 dB or better.

Performance criterion B:

Use the general performance criterion B. See GENERAL PERFORMANCE CRITERIA.

Performance criterion C:

Use the general performance criterion C. See GENERAL PERFORMANCE CRITERIA.

6.5 ELECTROSTATIC DISCHARGE IMMUNITY TEST (ESD)

6.5.1 TEST SPECIFICATION

Basic Standard	IEC 61000-4-2
Discharge Impedance	330 ohm / 150 pF
Required Performance	B
Discharge Voltage	Air Discharge: $\pm 2\text{kV}$, $\pm 4\text{kV}$, $\pm 8\text{kV}$ Contact Discharge: $\pm 2\text{kV}$, $\pm 4\text{kV}$
Polarity	Positive & Negative
Number of Discharge	20 times at each test point
Discharge Mode	Single Discharge
Discharge Period	1 second

6.5.2 MEASUREMENT INSTRUMENTS

Item	Kind of Equipment	Manufacturer	Type No.	Series Model	Calibrated until
1	ESD Generator	TESEQ AG	NSG 437	450	Sep. 15, 2021

Remark: "N/A" denotes no model no., no serial No. or no calibration specified.

All calibration period of equipment list is one year.

6.5.3 TEST PROCEDURE

The test generator necessary to perform direct and indirect application of discharges to the EUT in the following manner:

- a. The test shall be performed with single discharges. On each pre-selected point at least 10 single discharges (in the most sensitive polarity) shall be applied.
 NOTE 1 The minimum number of discharges applied is depending on the EUT; for products with synchronized circuits the number of discharges should be larger.
 For the time interval between successive single discharges an initial value of 1 s is recommended. Longer intervals may be necessary to determine whether a system failure has occurred.
 NOTE 2 The points to which the discharges should be applied may be selected by means of an exploration carried out at a repetition rate of 20 discharges per second, or more.
 Vertical Coupling Plane (VCP):
 The coupling plane, of dimensions 0.5m x 0.5m, is placed parallel to, and positioned at a distance 0.1m from, the EUT, with the Discharge Electrode touching the coupling plane.
 The four faces of the EUT will be performed with electrostatic discharge.
 Horizontal Coupling Plane (HCP):
 The coupling plane is placed under to the EUT. The generator shall be positioned vertically at a distance of 0.1m from the EUT, with the Discharge Electrode touching the coupling plane.
 The four faces of the EUT will be performed with electrostatic discharge.
- b. For TABLE-TOP equipment:
 The configuration consisted of a wooden table 0.8 meters high standing on the Ground Reference Plane. The GRP consisted of a sheet of aluminum at least 0.25mm thick, and 2.5 meters square connected to the protective grounding system. A Horizontal Coupling Plane (1.6m x 0.8m) was placed on the table and attached to the GRP by means of a cable with 940k total impedance. The equipment under test was installed in a representative system as described in IEC 61000-4-2, and its cables were placed on the HCP and isolated by an insulating support of 0.5mm thickness. A distance of 1-meter minimum was provided between the EUT and the walls of the laboratory and any other metallic structure.

6.5.4 DEVIATION FROM TEST STANDARD

No deviation

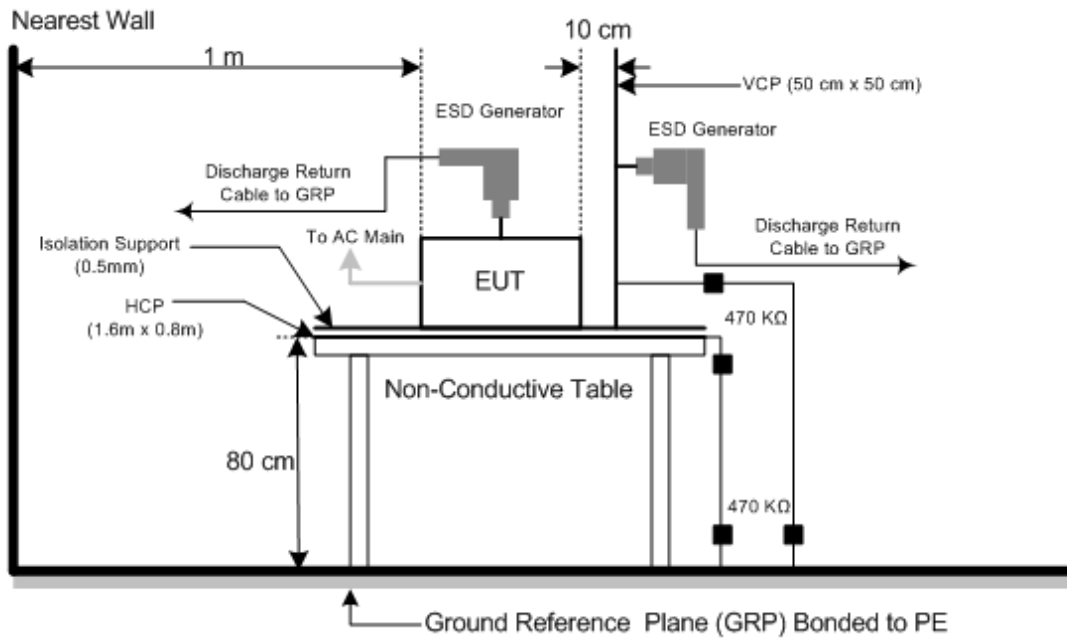
6.5.5 TEST SETUP

6.5.6 TEST RESULTS

Test Voltage	AC 230V/50Hz
Test Mode	Mode 1-5, Mode 8, Mode 9

Mode	Air Discharge							Contact Discharge							
	2kV		4kV		8kV		- kV		2kV		4kV		- kV		
Test Level	P	N	P	N	P	N	P	N	P	N	P	N	P	N	
Location	P	N	P	N	P	N	P	N	P	N	P	N	P	N	
1	A	A	A	A	B	B	-	-	A	A	B	B	-	-	
2	A	A	A	A	A	A	-	-	A	A	B	B	-	-	
3	A	A	A	A	A	A	-	-	-	-	-	-	-	-	
4	A	A	A	A	A	A	-	-	-	-	-	-	-	-	
5	A	A	A	A	A	A	-	-	-	-	-	-	-	-	
6	A	A	A	A	A	A	-	-	-	-	-	-	-	-	
7	A	A	A	A	A	A	-	-	-	-	-	-	-	-	
Criteria	B							-		B				-	
Result	B							-		B				-	

Mode	HCP Contact Discharge						VCP Contact Discharge							
	2kV		4kV		- kV		2kV		4kV		- kV			
Test Level	P	N	P	N	P	N	P	N	P	N	P	N		
Location	P	N	P	N	P	N	P	N	P	N	P	N		
Left side	A	A	A	A	-	-	A	A	A	A	-	-		
Right side	A	A	A	A	-	-	A	A	A	A	-	-		
Front side	A	A	A	A	-	-	A	A	A	A	-	-		
Rear side	A	A	A	A	-	-	A	A	A	A	-	-		
Criteria	B						-		B				-	
Result	A						-		A				-	

Note:

- 1) P/N denotes the Positive/Negative polarity of the output voltage.
- 2) N/A - denotes test is not applicable in this test report

PHOTO(S) SHOWN THE LOCATION(S) OF ESD EVALUATED

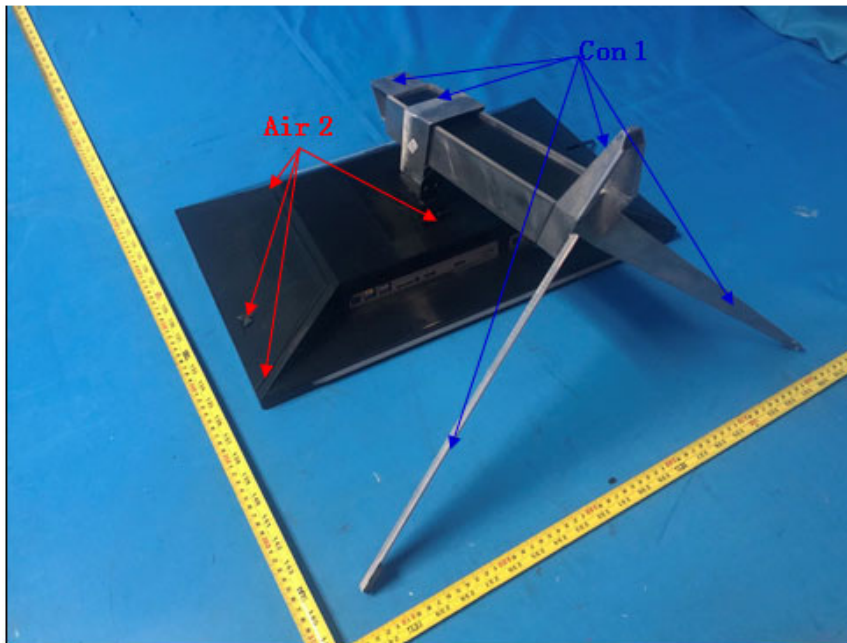
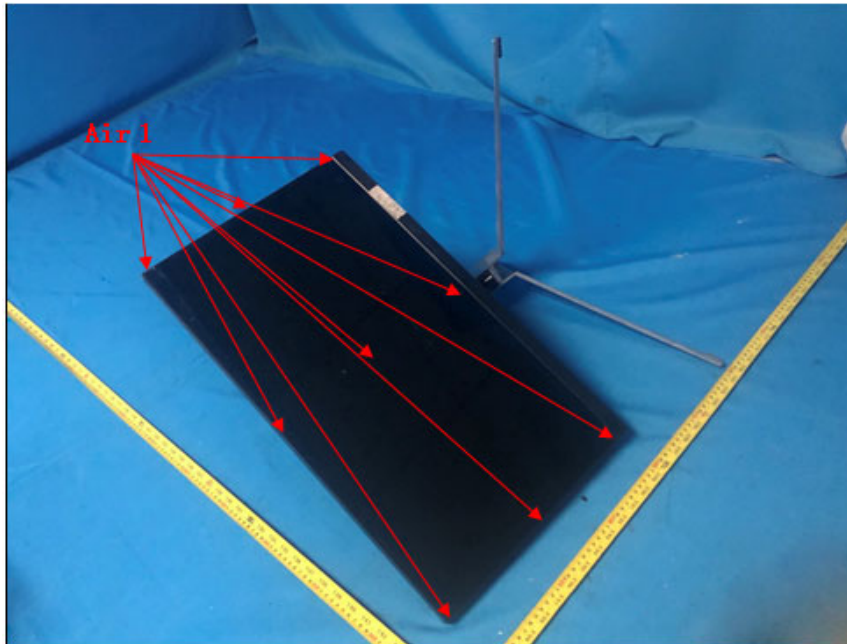

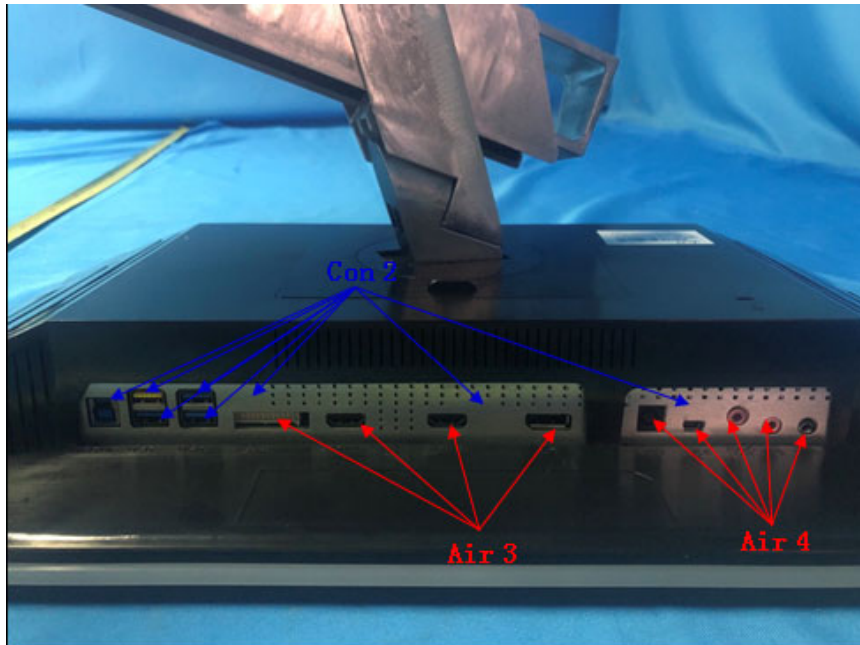

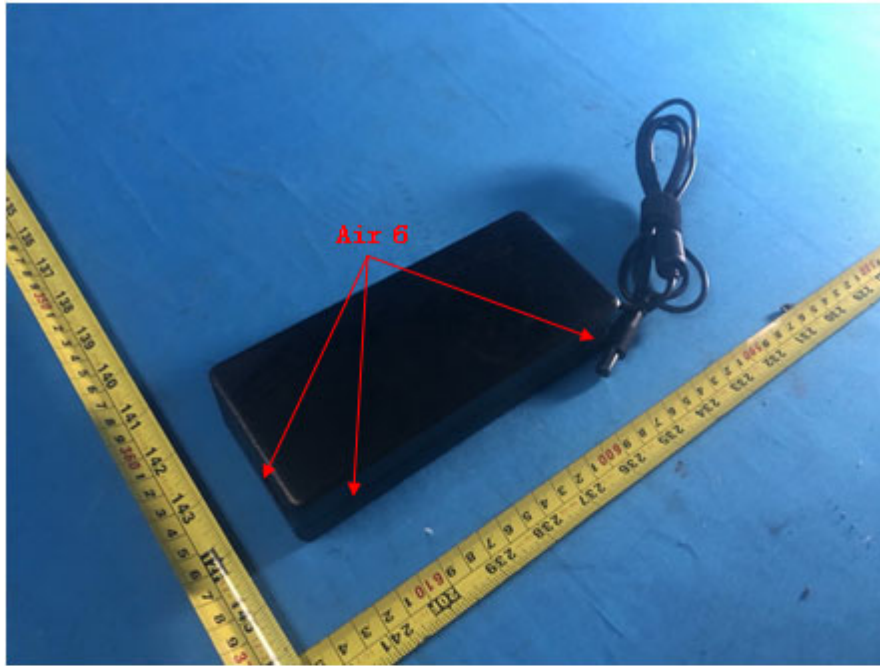

6.6 RADIATED, RADIO-FREQUENCY, ELECTROMAGNETIC FIELD IMMUNITY TEST (RS)

6.6.1 TEST SPECIFICATION

Basic Standard	IEC 61000-4-3
Required Performance	A
Frequency Range	80 MHz - 1000 MHz, 1800 MHz, 2600 MHz, 3500 MHz, 5000MHz
Field Strength	3 V/m(unmodulated, r.m.s)
Modulation	1 kHz Sine Wave, 80%, AM Modulation
Frequency Step	1% of fundamental
Polarity of Antenna	Horizontal and Vertical
Test Distance	3 m
Antenna Height	1.55 m
Dwell Time	3 seconds

6.6.2 MEASUREMENT INSTRUMENTS

Item	Kind of Equipment	Manufacturer	Type No.	Series Model	Calibrated until
1	Antenna	ETS	3142C	66462	Mar. 23, 2021
2*	Amplifier	AR	50S1G4A	326720	Apr. 08, 2021
3	MXG Analog Signal Generator	Agilent	N5181A	MY49060710	Jul. 25, 2021
4	Conditioning Amplifier	B&K	_2690__0F2_	2723746	Jun. 18, 2021
5*	Power amplifier	MILMEGA	AS1860-50	1064834	Mar. 01, 2021
6	Microwave Log.-Per. Antenna	TESEQ	STLP 9149	9149-277	Apr. 14, 2021
7*	Power amplifier	MILMEGA	80RF1000-250	1064833	Mar. 01, 2021
8	Measurement Software	TOYO	IM5/RS Ver 3.8.050	N/A	N/A
9	Free-field 1/2` Microphone	B&K	4190-L-001	2878077	Jun. 17, 2021
10	UPV Audio Analyzer	R&S	UPV	104259	Mar. 01, 2021

Remark: "N/A" denotes no model no., no serial No. or no calibration specified.

"*" calibration period of equipment list is three year.

Except * item, all calibration period of equipment list is one year.

6.6.3 TEST PROCEDURE

The EUT and support equipment are in a fully-anechoic chamber.

The testing distance from antenna to the EUT was 3 meters.

For TABLE-TOP equipment:

The EUT installed in a representative system as described in IEC 61000-4-3 was placed on a non-conductive table 0.8 meters in height. The system under test was connected to the power and signal wire according to relevant installation instructions.

The other condition as following manner:

- The field strength level was 3 V/m(unmodulated, r.m.s).
- The frequency range is swept from 80 MHz to 1000 MHz, with the signal 80%amplitude modulated with a 1 kHz sine wave. The rate of sweep did not exceed 1.5×10^{-3} decade/s. Where the frequency range is swept incrementally, the step size was 1% of fundamental.
- The dwell time at each frequency shall be not less than the time necessary for the EUT to be able to respond.
- The test was performed with the EUT exposed to both vertically and horizontally polarized fields on each of the four sides.

For Display and display output functions:

- a. The display quality evaluated by direct observation.
- b. For display output function evaluation, a suitable display device shall be connected. This device shall meet the immunity requirements for displays specified in this document. The screen size shall be typical for the display output. the diagonal screen size shall be at least 0,50 m.
- c. The display shall be observed under normal viewing conditions including viewing distance using a reduced ambient light level preferably in the range 15 lx to 20 lx. The viewing distance or settings of the video camera monitoring system shall be sufficient to provide visibility of the whole display. In the case of direct observation the selected viewing distance shall be recorded in the test report.

For Acoustic measurements:

- a. Apply an appropriate input signal to the EUT so that a sine wave (tone) at the frequency that will be used to modulate the applied disturbance (typically 1 kHz) is generated from the port under test at a level equal to the acoustic reference level.
- b. Record the resulting dB (SPL) level (or other appropriate dB unit) as the value of L_0 . (BTL lab uses the software to take L_0 as the reference value and make it return to zero.)
- c. Change the input to the EUT so that the port under test is silent, or represents silence. This change shall not alter the terminating impedance at the EUT's input.
- d. Apply the RF disturbance to the applicable port of the EUT and record the resulting demodulated audio level in dB (SPL) (or other dB unit used in step d)) as the value of L_1 .
- e. Ensure that non-linear processing does not impact the measurements.
- f. Calculate the acoustic interference ratio using the following formula:
 Acoustic interference ratio = $L_1 - L_0$.
 (For step e-g, BTL lab proceeds the test with software and calculate Acoustic interference ratio = $L_1 - L_0$).

6.6.4 DEVIATION FROM TEST STANDARD

No deviation

6.6.5 TEST SETUP

- a) For Continuous induced RF disturbances

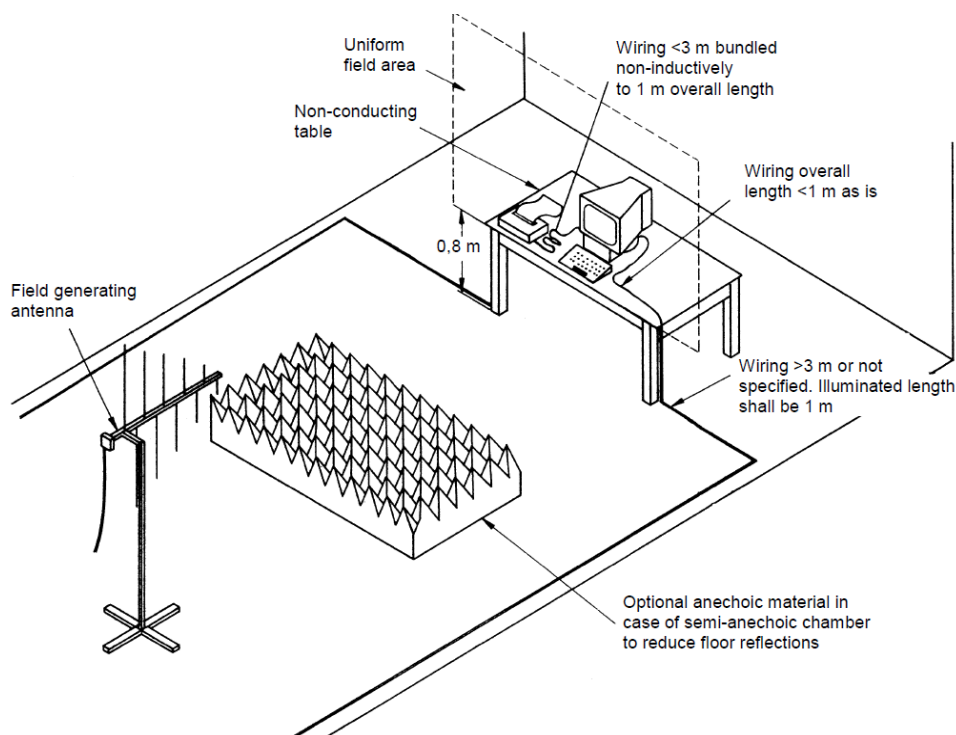

For Audio output function

(1) Audio output port

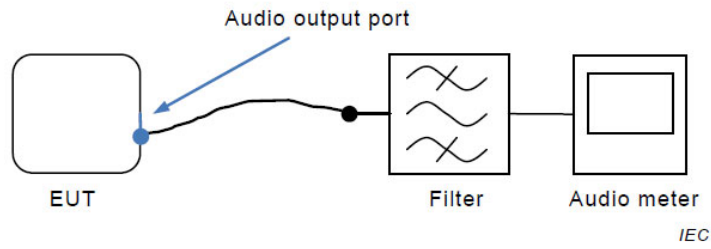

The filter is the audio filter specified in G.6.1 and is typically incorporated into the audio meter. Additional filtering might be necessary to ensure that the RF disturbance signal does not interfere with the measurement.

(2) Loudspeaker

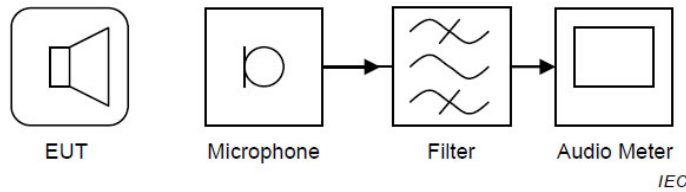

The filter is the audio filter specified in G.6.1 and is typically incorporated into the audio meter. Additional filtering might be necessary to ensure that the RF disturbance signal does not interfere with the measurement.

6.6.6 TEST RESULTS

Test Voltage	AC 230V/50Hz
Test Mode	Mode 1-5, Mode 8, Mode 9

Frequency Range (MHz)	RF Field Position	R.F. Field Strength	Modulation	Azimuth	Criterion	Result
80 - 1000	H / V	3V/m	AM Modulated 1000Hz, 80%	0	A	A
				90		
				180		
				270		
1800, 2600, 3500, 5000 (±1%)	H / V	3V/m	AM Modulated 1000Hz, 80%	0	A	A
				90		
				180		
				270		

For Audio output function

(1) Audio output port:

Test Voltage	AC 230V/50Hz
Test Mode	Mode 1_Vertical_Front

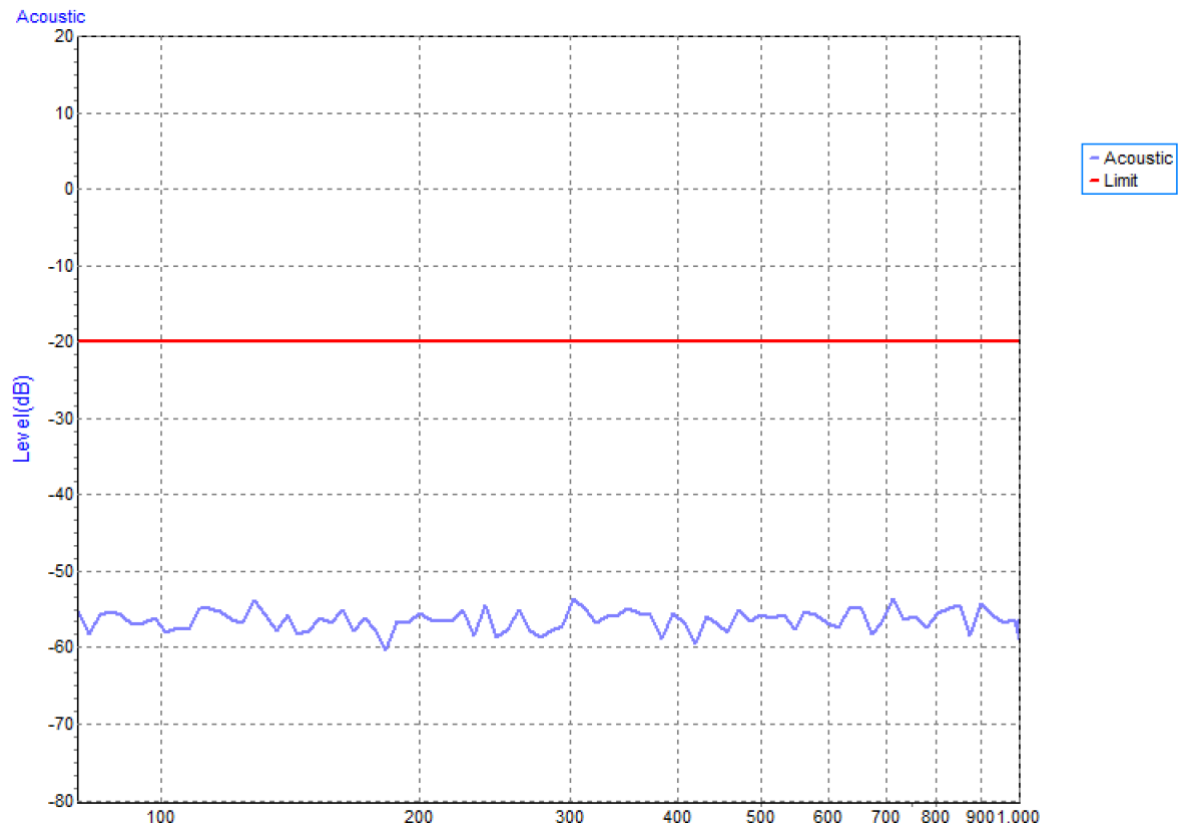

Test Voltage	AC 230V/50Hz
Test Mode	Mode 1_Horizontal_Front

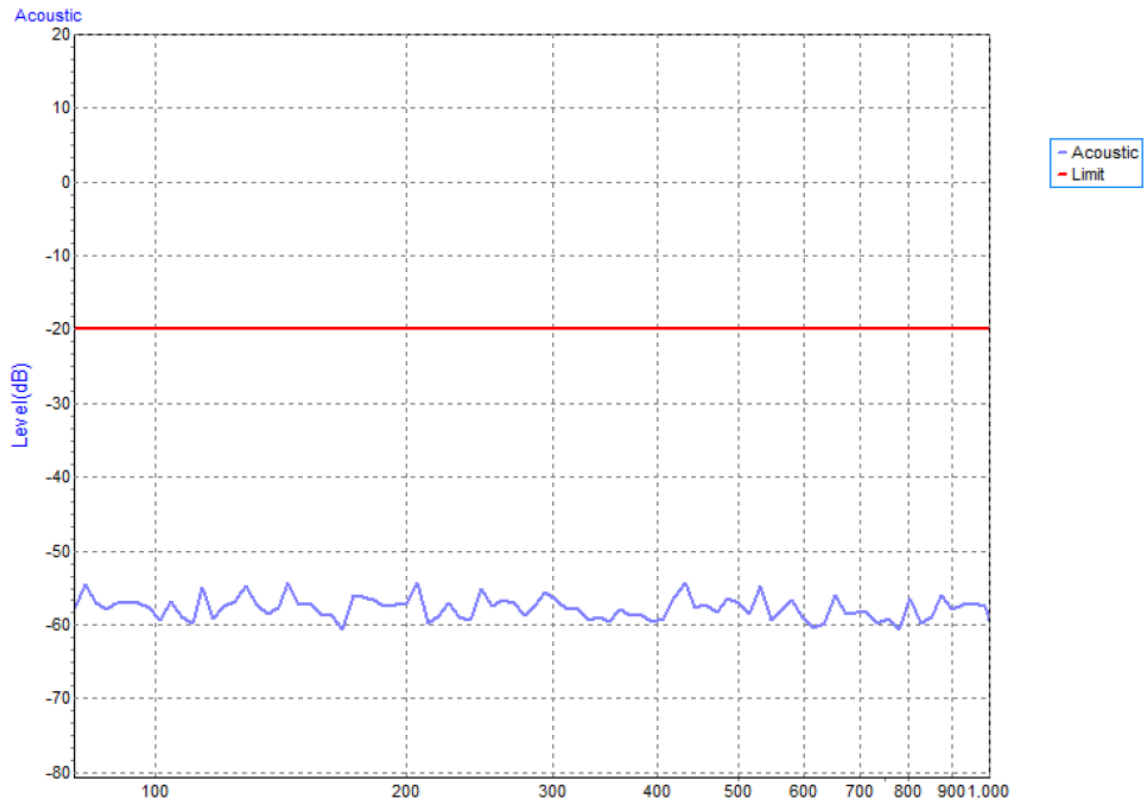

(2) Loudspeaker :

Test Voltage	AC 230V/50Hz
Test Mode	Mode 1_Vertical_Front

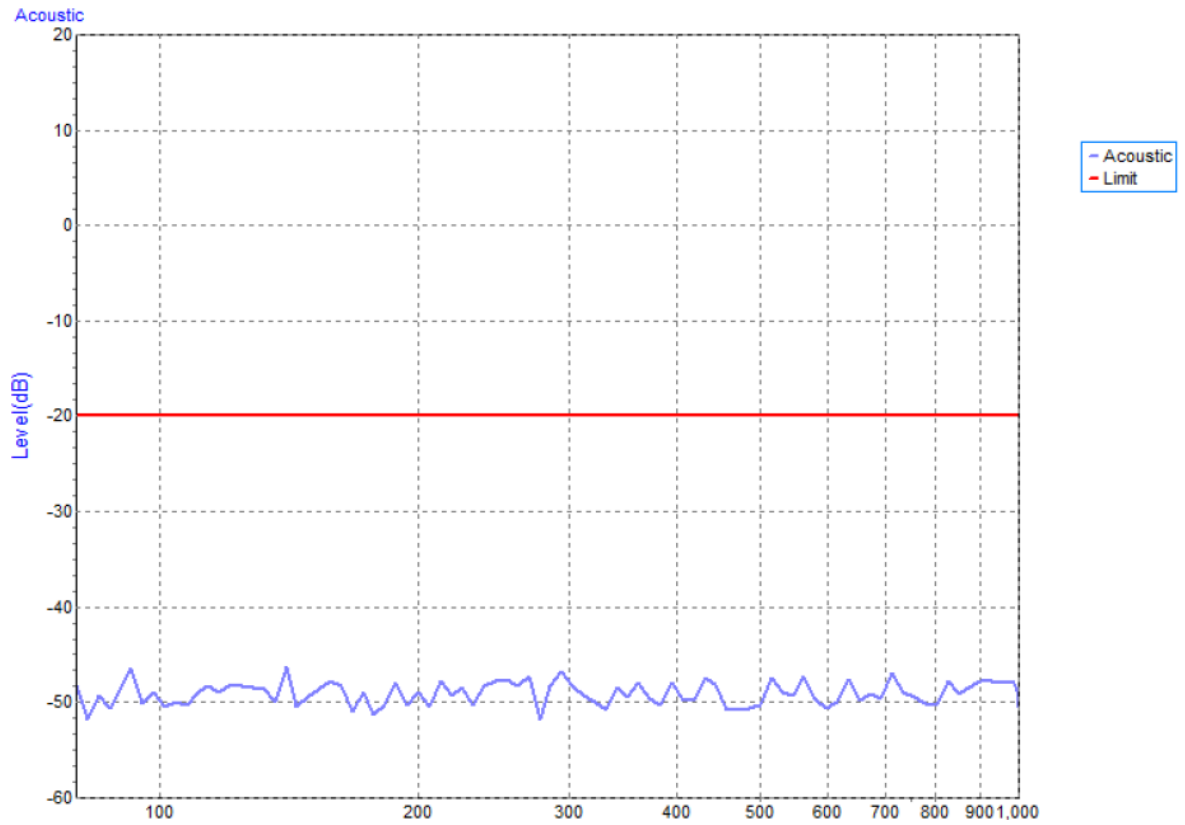

Test Voltage	AC 230V/50Hz
Test Mode	Mode 1_Horizontal_Front

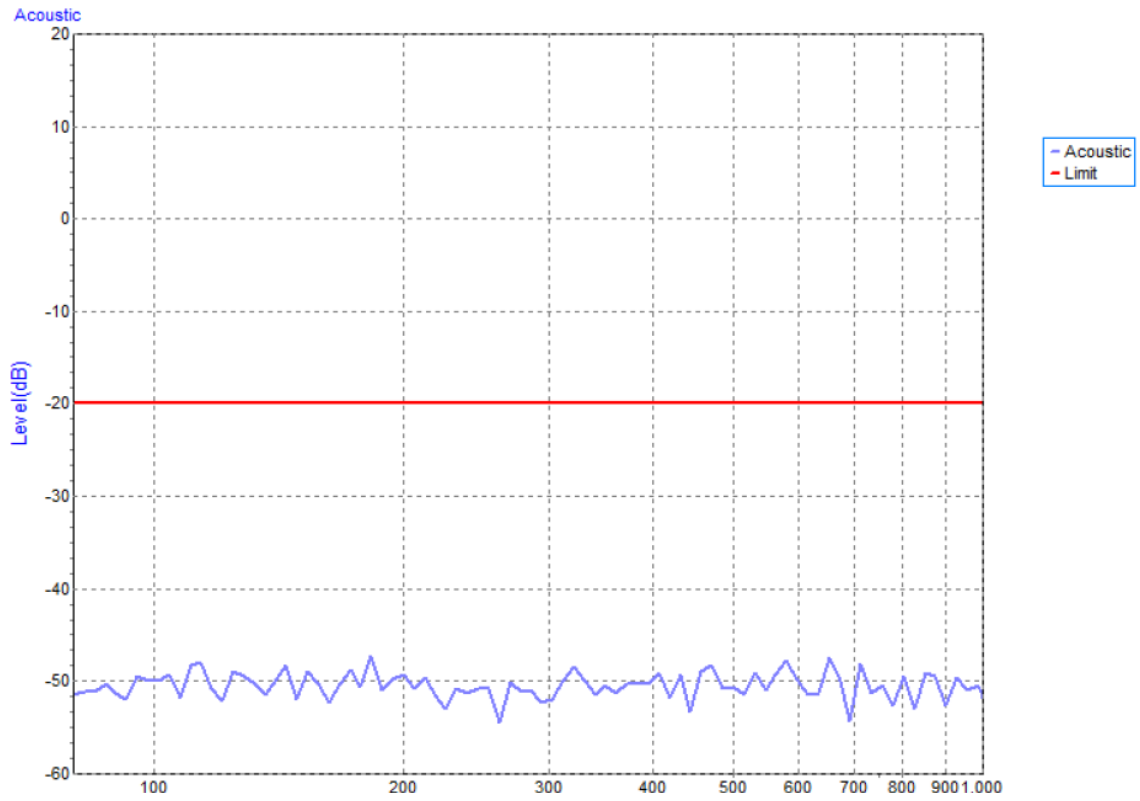

6.7 ELECTRICAL FAST TRANSIENT/BURST IMMUNITY TEST (EFT/BURST)

6.7.1 TEST SPECIFICATION

Basic Standard	IEC 61000-4-4
Required Performance	B
Test Voltage	AC Power Ports:±1 kV
Polarity	Positive & Negative
Impulse Frequency	5 kHz: except for xDSL ports.
Impulse Wave shape	5/50 ns
Burst Duration	15 ms
Burst Period	300 ms
Test Duration	1 min.

6.7.2 MEASUREMENT INSTRUMENTS

Item	Kind of Equipment	Manufacturer	Type No.	Series Model	Calibrated until
1	Fast Transient Burst Simulator	Prima	EFT61004TA	PR190741004	Jul. 25, 2021

Remark: "N/A" denotes no model no., no serial No. or no calibration specified.

All calibration period of equipment list is one year.

6.7.3 TEST PROCEDURE

For TABLE-TOP equipment:

The configuration consisted of a wooden table (0.8m high) standing on the Ground Reference Plane and should be located 0.1 m+/- 0.01m above the Ground Reference Plane. The GRP consisted of a sheet of aluminum (at least 0.25mm thick and 2.5m square) connected to the protective grounding system. A minimum distance of 0.5m was provided between the EUT and the walls of the laboratory or any other metallic structure.

The other condition as following manner:

- a. Both positive and negative polarity discharges were applied.
- b. The duration time of each test sequential was 1 minute.

6.7.4 DEVIATION FROM TEST STANDARD

No deviation

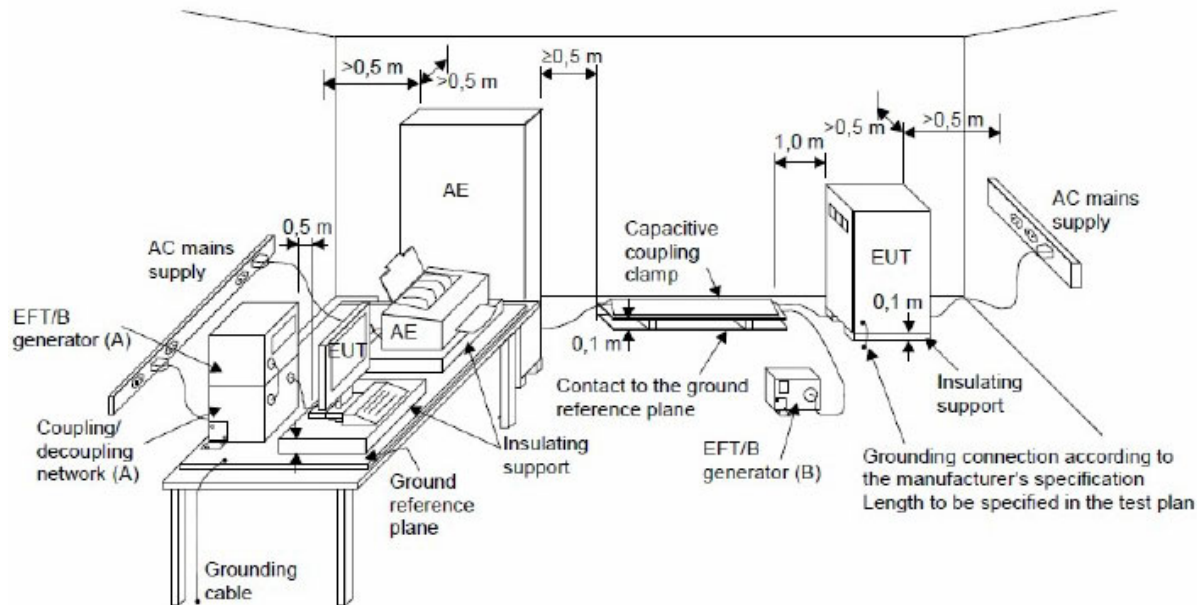
6.7.5 TEST SETUP

6.7.6 TEST RESULTS

Test Voltage	AC 230V/50Hz
Test Mode	Mode 1-5, Mode 8, Mode 9

EUT Ports Tested		Polarity	Repetition Frequency	Test Level	Criterion	Result
				1kV		
AC Power Port	Line (L)	+	5 kHz	A	B	A
		-	5 kHz	A		
	Neutral (N)	+	5 kHz	A	B	A
		-	5 kHz	A		
	Ground (PE)	+	5 kHz	A	B	A
		-	5 kHz	A		
	L+N	+	5 kHz	A	B	A
		-	5 kHz	A		
	L+PE	+	5 kHz	A	B	A
		-	5 kHz	A		
	N+PE	+	5 kHz	A	B	A
		-	5 kHz	A		
	L+N+PE	+	5 kHz	A	B	A
		-	5 kHz	A		

6.8 SURGE IMMUNITY TEST

6.8.1 TEST SPECIFICATION

Basic Standard	IEC 61000-4-5
Required Performance	B
Wave-Shape	1.2/50(8/20) Tr/Th μ s combination wave
Test Voltage	AC Power Port: ± 0.5 kV, ± 1 kV, ± 2 kV
Generator Source Impedance	2 Ω of the low-voltage power supply network. 12 Ω (10 Ω +2 Ω) of the low-voltage power supply network and ground.
Phase Angle, Polarity and Number of Tests	Five positive pulses line-to-neutral at 90° phase Five negative pulses line-to-neutral at 270° phase Five positive pulses line-to-earth at 90° phase Five negative pulses line-to-earth at 270° phase Five negative pulses neutral-to-earth at 90° phase Five positive pulses neutral-to-earth at 270° phase
Pulse Repetition Rate	1 time / min.

6.8.2 MEASUREMENT INSTRUMENTS

Item	Kind of Equipment	Manufacturer	Type No.	Series Model	Calibrated until
1	Lightning Surge Generator	Prima	SUG61005TB	PR190854067	Jul. 25, 2021

Remark: "N/A" denotes no model no., no serial No. or no calibration specified.

All calibration period of equipment list is one year.

6.8.3 TEST PROCEDURE

a. For EUT power supply:

The surge is to be applied to the EUT power supply terminals via the capacitive coupling network. Decoupling networks are required in order to avoid possible adverse effects on equipment not under test that may be powered by the same lines, and to provide sufficient decoupling impedance to the surge wave. The power cord between the EUT and the coupling/decoupling networks shall be 2 meters in length (or shorter).

b. For test applied to unshielded unsymmetrically operated interconnection lines of EUT :

The surge is applied to the lines via the capacitive coupling. The coupling /decoupling networks shall not influence the specified functional conditions of the EUT. The interconnection line between the EUT and the coupling/decoupling networks shall be 2 meters in length (or shorter).

c. For test applied to unshielded symmetrically operated interconnection /telecommunication lines of EUT :

The surge is applied to the lines via gas arrestors coupling. Test levels below the ignition point of the coupling arrestor cannot be specified. The interconnection line between the EUT and the coupling/decoupling networks shall be 2 meters in length (or shorter).

6.8.4 DEVIATION FROM TEST STANDARD

No deviation

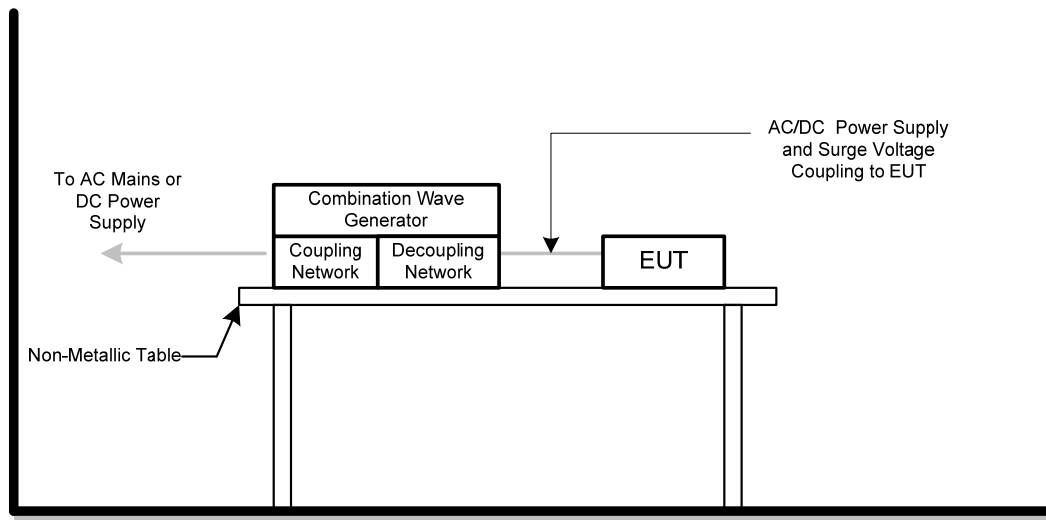
6.8.5 TEST SETUP

6.8.6 TEST RESULTS

Test Voltage	AC 230V/50Hz
Test Mode	Mode 1-5, Mode 8, Mode 9

Wave Form EUT Ports Tested		1.2/50(8/20)Tr/Th μ s						Criterion	Result
		Polarity	Phase	Voltage					
				0.5kV	1kV	-- kV	-- kV		
AC	L – N	+	90°	A	A	-	-	B	A
		-	270°	A	A	-	-		

Wave Form EUT Ports Tested		1.2/50(8/20)Tr/Th μ s						Criterion	Result
		Polarity	Phase	Voltage					
				0.5kV	1kV	2kV	-- kV		
AC	L – PE	+	90°	A	A	A	-	B	A
		-	270°	A	A	A	-		
	N – PE	-	90°	A	A	A	-	B	A
		+	270°	A	A	A	-		

6.9 IMMUNITY TO CONDUCTED DISTURBANCES, INDUCED BY RADIO-FREQUENCY FIELDS TEST (CS)

6.9.1 TEST SPECIFICATION

Basic Standard	IEC 61000-4-6
Required Performance	A
Frequency Range&Field Strength	0.15 MHz - 10 MHz: 3V (unmodulated, r.m.s.) 10 MHz - 30 MHz: 3V to 1V (unmodulated, r.m.s.) 30 MHz - 80 MHz: 1V (unmodulated, r.m.s.)
Modulation	1 kHz Sine Wave, 80%, AM Modulation
Frequency Step	1% of fundamental
Dwell Time	3 seconds

6.9.2 MEASUREMENT INSTRUMENTS

Item	Kind of Equipment	Manufacturer	Type No.	Series Model	Calibrated until
1	Power CDN	FCC	FCC-801-M2/M3-16A	100270	Feb. 28, 2021
2	TEST SYSTEM FOR CONDUCTED AND RADIATED IMMUNITY	TESEQ	NSG 4070B	37513	Jul. 25, 2021
3	Measurement Software	Farad	EZ-CS(V2.0.1.2)	N/A	N/A
4	Conditioning Amplifier	B&K	2690_0F2	2723746	Jun. 18, 2021
5	Free-field 1/2` Microphone	B&K	4190-L-001	2878077	Jun. 17, 2021
6	UPV Audio Analyzer	R&S	UPV	104259	Mar. 01, 2021

Remark: "N/A" denotes no model no., no serial No. or no calibration specified.

All calibration period of equipment list is one year.

6.9.3 TEST PROCEDURE

The equipment to be tested is placed on an insulating support of 0.1m height above a reference ground plane. All cables exiting the EUT shall be supported at a height of at least 30 mm above the reference ground plane. All relevant cables shall be provided with the appropriate coupling and decoupling devices at a distance between 0.1 meters and 0.3 meters from the projected geometry of the EUT on the ground reference plane.

The other condition as following manner:

- The field strength level was 3 V (unmodulated, r.m.s.)
- The frequency range is swept from 150 kHz to 80 MHz, with the signal 80%amplitude modulated with a 1 kHz sine wave. The rate of sweep did not exceed 1.5x 10⁻³ decade/s. Where the frequency range is swept incrementally, the step size was 1% of fundamental.
- The dwell time at each frequency shall be not less than the time necessary for the EUT to be able to respond.

For Display and display output functions:

- The display quality evaluated by direct observation.
- For display output function evaluation, a suitable display device shall be connected. This device shall meet the immunity requirements for displays specified in this document. The screen size shall be typical for the display output.the diagonal screen size shall be at least 0,50 m.
- The display shall be observed under normal viewing conditions including viewing distance using a reduced ambient light level preferably in the range 15 lx to 20 lx. The viewing distance or settings of the video camera monitoring system shall be sufficient to provide visibility of the whole display. In the case of direct observation the selected viewing distance shall be recorded in the test report.

For Acoustic measurements:

- a. Apply an appropriate input signal to the EUT so that a sine wave (tone) at the frequency that will be used to modulate the applied disturbance (typically 1 kHz) is generated from the port under test at a level equal to the acoustic reference level.
- b. Record the resulting dB (SPL) level (or other appropriate dB unit) as the value of L_0 . (BTL lab uses the software to take L_0 as the reference value and make it return to zero.)
- c. Change the input to the EUT so that the port under test is silent, or represents silence. This change shall not alter the terminating impedance at the EUT's input.
- d. Apply the RF disturbance to the applicable port of the EUT and record the resulting demodulated audio level in dB (SPL) (or other dB unit used in step d)) as the value of L_1 .
- e. Ensure that non-linear processing does not impact the measurements.
- f. Calculate the acoustic interference ratio using the following formula:
 Acoustic interference ratio = $L_1 - L_0$.
 (For step e-g, BTL lab proceeds the test with software and calculate Acoustic interference ratio = $L_1 - L_0$).

6.9.4 DEVIATION FROM TEST STANDARD

No deviation

6.9.5 TEST SETUP

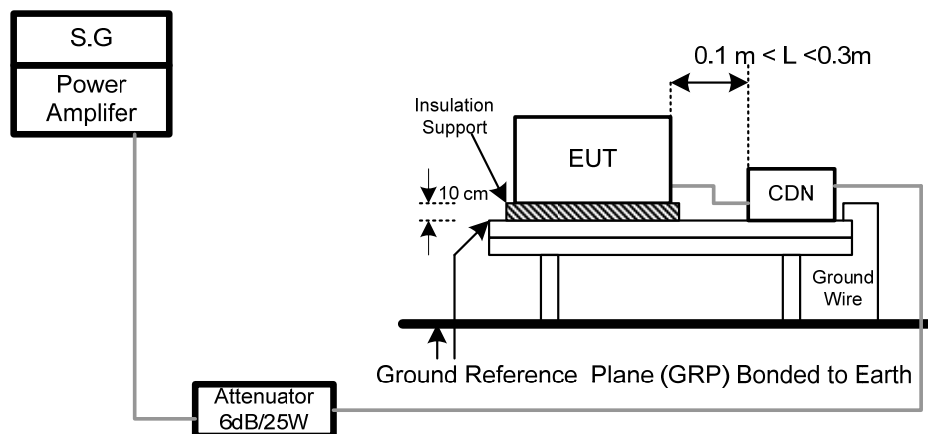

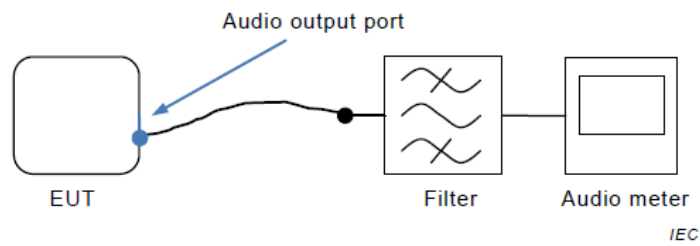
For Audio output function**(1) Audio output port**

The filter is the audio filter specified in G.6.1 and is typically incorporated into the audio meter. Additional filtering might be necessary to ensure that the RF disturbance signal does not interfere with the measurement.

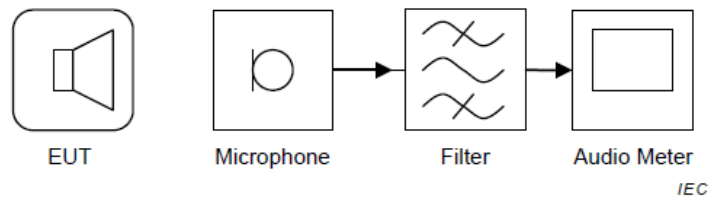
(2) Loudspeaker

The filter is the audio filter specified in G.6.1 and is typically incorporated into the audio meter. Additional filtering might be necessary to ensure that the RF disturbance signal does not interfere with the measurement.

6.9.6 TEST RESULTS

Test Voltage	AC 230V/50Hz
Test Mode	Mode 1-5, Mode 8, Mode 9

Test Ports (Mode)	Freq.Range (MHz)	Field Strength	Modulation	Criteria	Results
AC mains power ports	0.15 - 10	3V	AM Modulated 1000Hz, 80%	A	A
	10 - 30	3V to 1V			
	30 - 80	1V			

For Audio output function

(1) Audio output port:

Test Voltage	AC 230V/50Hz
Test Mode	Mode 1_CDN M3

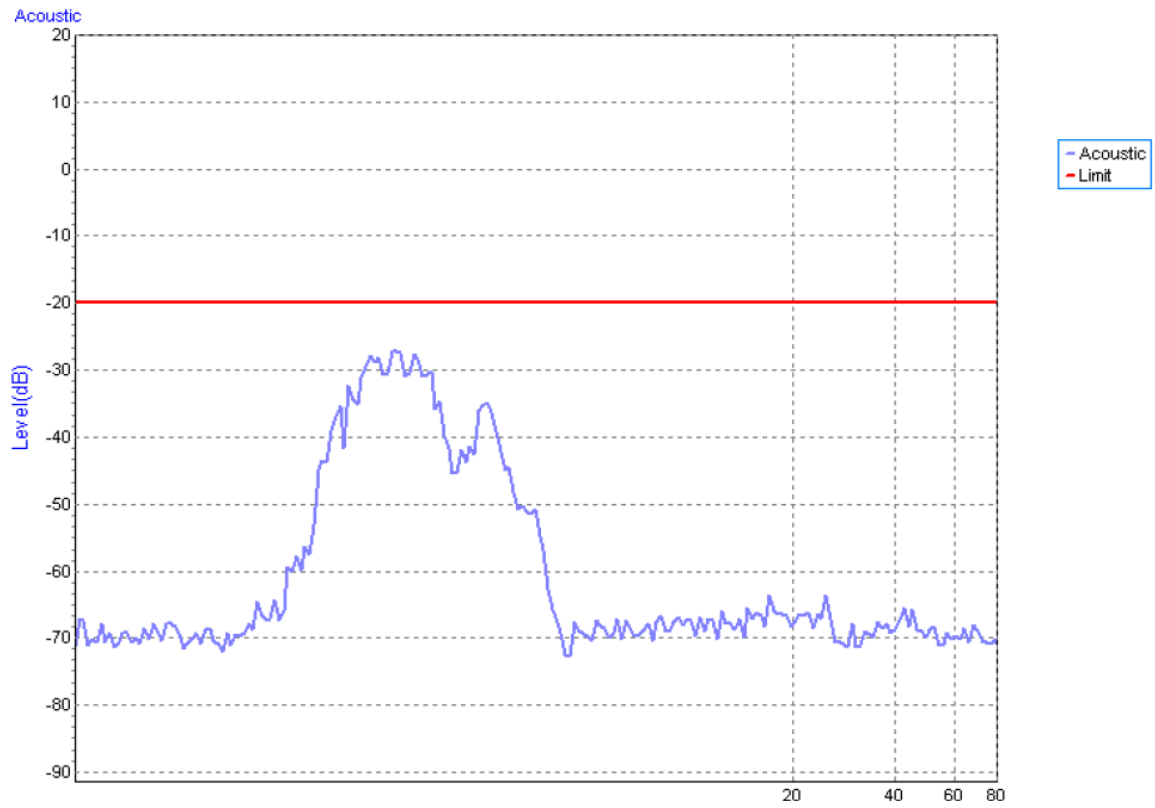

(2) Loudspeaker:

Test Voltage	AC 230V/50Hz
Test Mode	Mode 1_CDN M3

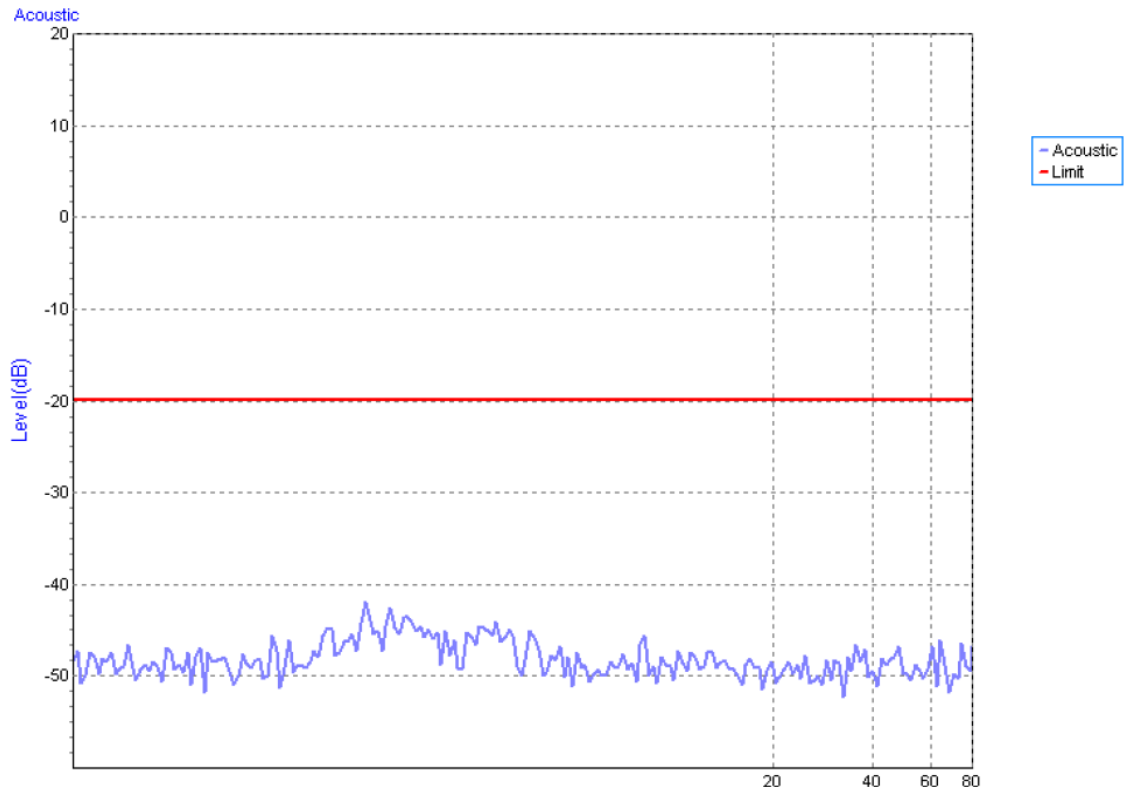

6.10 POWER FREQUENCY MAGNETIC FIELD IMMUNITY TEST (PFMF)

6.10.1 TEST SPECIFICATION

Basic Standard	IEC 61000-4-8
Required Performance	A
Frequency Range	50/60 Hz
Field Strength	1 A/m
Observation Time	1 minute
Inductance Coil	Rectangular type, 1mx1m

6.10.2 MEASUREMENT INSTRUMENTS

Item	Kind of Equipment	Manufacturer	Type No.	Series Model	Calibrated until
1	Magnetic Field test Generator	FCC	F-1000-4-8-G-125A	4032	Mar. 01, 2021
2	Magnetic Field immunity loop	Thermo KeyTek	F-1000-4-8/9/10-L-1M	4024	Mar. 01, 2021

Remark: "N/A" denotes no model no., no serial No. or no calibration specified.

All calibration period of equipment list is one year.

6.10.3 TEST PROCEDURE

For TABLE-TOP equipment:

The equipment shall be subjected to the test magnetic field by using the induction coil of standard dimension (1 m x 1 m). The induction coil shall then be rotated by 90 degrees in order to expose the EUT to the test field with different orientations.

The other condition as following manner:

- a. The equipment cabinets shall be connected to the safety earth directly on the GRP via the earth terminal of the EUT.
- b. The cables supplied or recommended by the equipment manufacturer shall be used. 1 meter of all cables used shall be exposed to the magnetic field.

6.10.4 DEVIATION FROM TEST STANDARD

No deviation

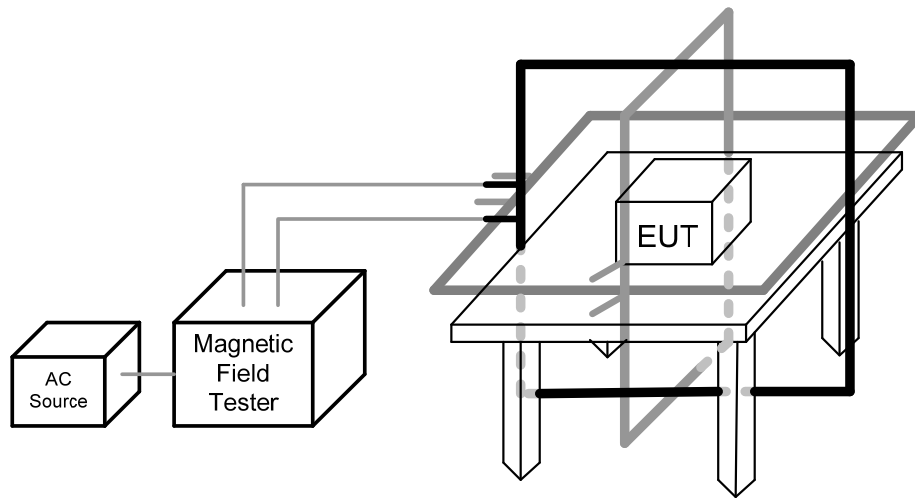
6.10.5 TEST SETUP

6.10.6 TEST RESULTS

Test Voltage	AC 230V/50Hz
Test Mode	Mode 1-5, Mode 8, Mode 9

50Hz

Test Mode	Test Level	Antenna aspect	Duration (s)	Criteria	Results
Enclosure	1 A/m	X	60	A	A
Enclosure	1 A/m	Y	60	A	A
Enclosure	1 A/m	Z	60	A	A

60Hz

Test Mode	Test Level	Antenna aspect	Duration (s)	Criteria	Results
Enclosure	1 A/m	X	60	A	A
Enclosure	1 A/m	Y	60	A	A
Enclosure	1 A/m	Z	60	A	A

6.11 VOLTAGE DIPS, SHORT INTERRUPTIONS AND VOLTAGE VARIATIONS IMMUNITY TEST (DIPS)

6.11.1 TEST SPECIFICATION

Basic Standard	IEC 61000-4-11
Required Performance	Voltage dips: B (For <5% residual voltage, dips) C (For 70% residual voltage, dips) C (For <5% residual voltage, Interruptions)
Interval between Event	Ten seconds
Phase Angle	0°/180°
Test Cycle	3 times

6.11.2 MEASUREMENT INSTRUMENTS

Item	Kind of Equipment	Manufacturer	Type No.	Series Model	Calibrated until
1	Cycle Sag Simulator	Prima	DRP61011TA	PR19076452	Dec. 03, 2021

Remark: "N/A" denotes no model no., no serial No. or no calibration specified.

All calibration period of equipment list is one year.

6.11.3 TEST PROCEDURE

The EUT shall be tested for each selected combination of test levels and duration with a sequence of three dips/interruptions with intervals of 10 s minimum (between each test event). Each representative mode of operation shall be tested. Abrupt changes in supply voltage shall occur at zero crossings of the voltage waveform.

6.11.4 DEVIATION FROM TEST STANDARD

No deviation

6.11.5 TEST SETUP

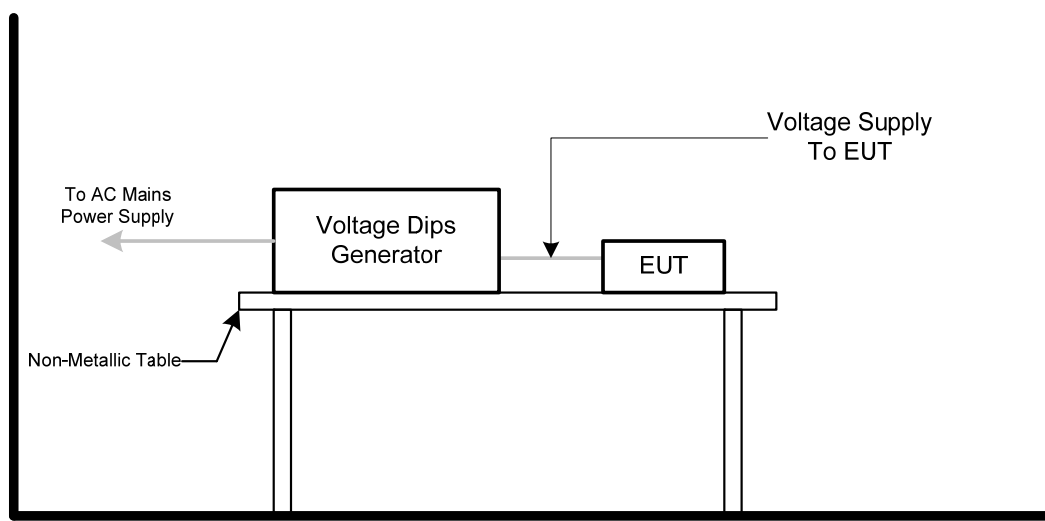

6.11.6 TEST RESULTS

Test Voltage	AC 100V/50Hz, AC 230V/50Hz, AC 240V/50Hz
Test Mode	Mode 1-5, Mode 8, Mode 9

AC 100V/50Hz				
Item	Residual Voltage	Cycle	Criteria	Results
Voltage dips	<5%	0.5	B	A
Voltage dips	70%	25	C	A
Voltage Interruption	<5%	250	C	C

AC 230V/50Hz				
Item	Residual Voltage	Cycle	Criteria	Results
Voltage dips	<5%	0.5	B	A
Voltage dips	70%	25	C	A
Voltage Interruption	<5%	250	C	C

AC 240V/50Hz				
Item	Residual Voltage	Cycle	Criteria	Results
Voltage dips	<5%	0.5	B	A
Voltage dips	70%	25	C	A
Voltage Interruption	<5%	250	C	C

7. EUT TEST PHOTO

EN 55032:2012+AC:2013&2015

Radiated emissions up to 1 GHz

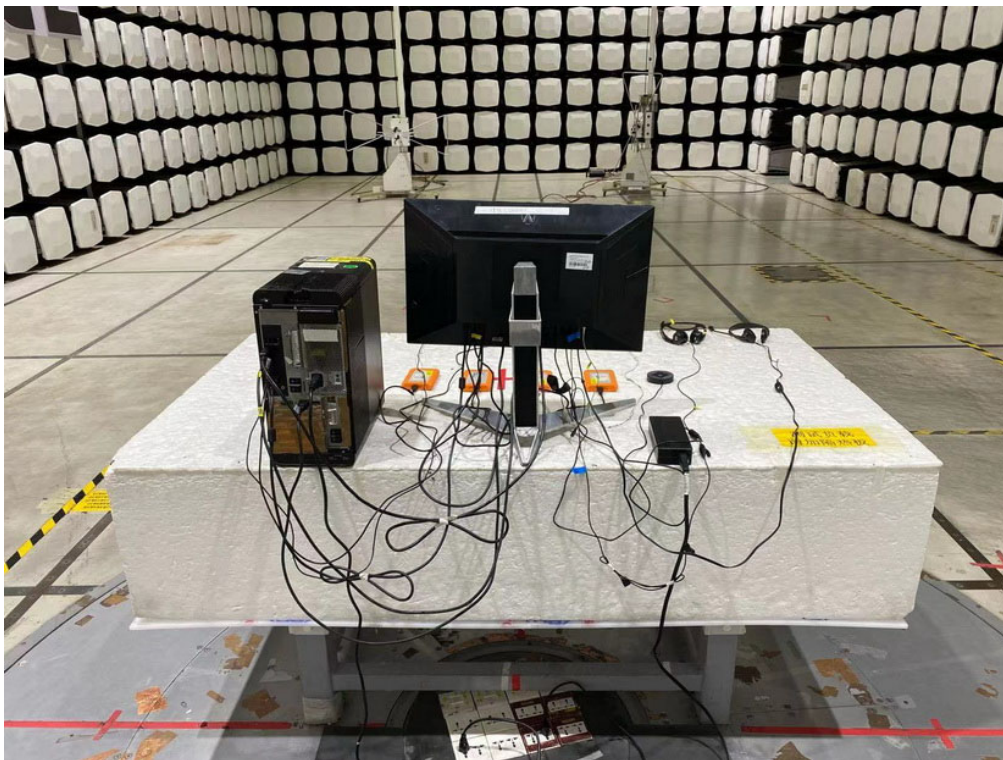

Radiated emissions above 1 GHz

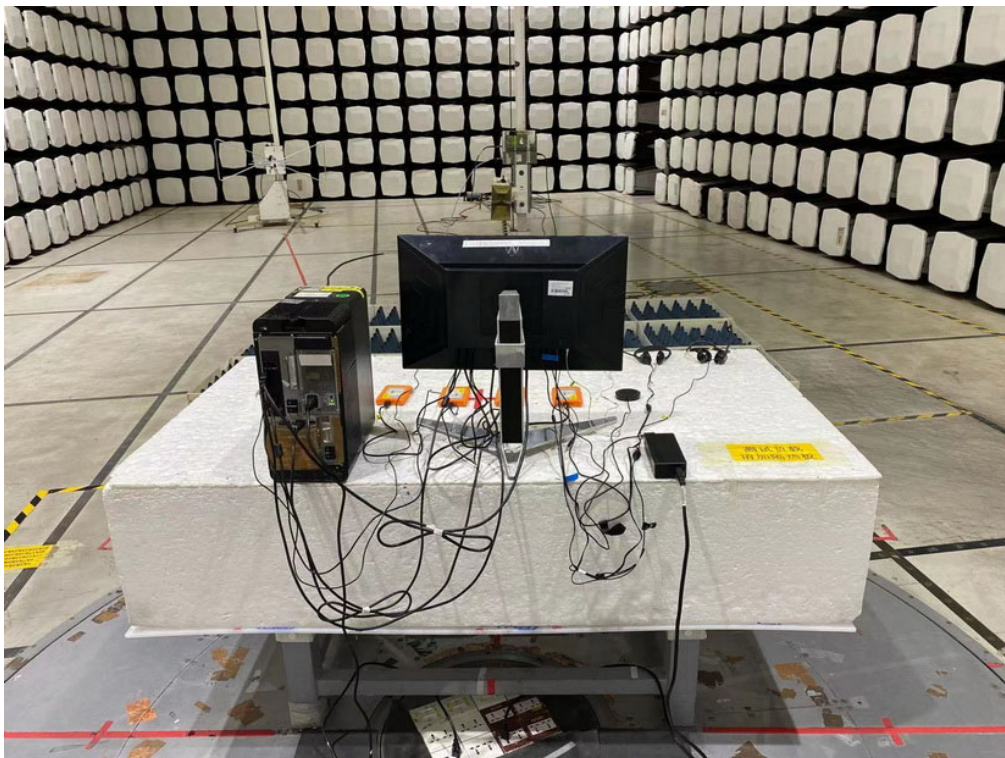
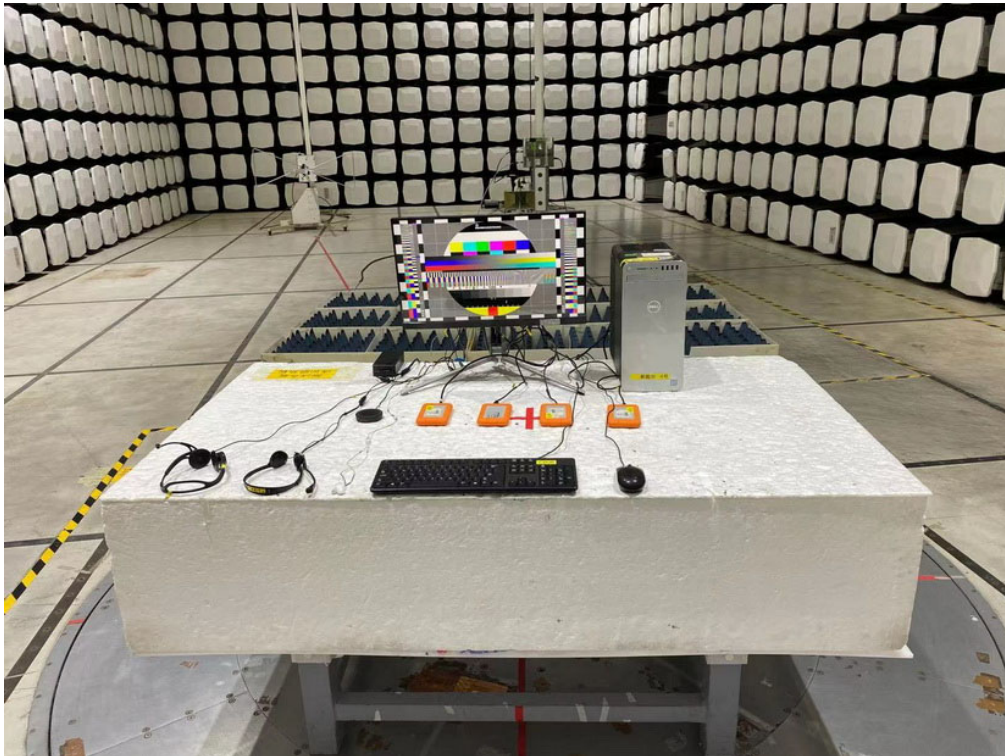

Conducted emissions AC mains power port

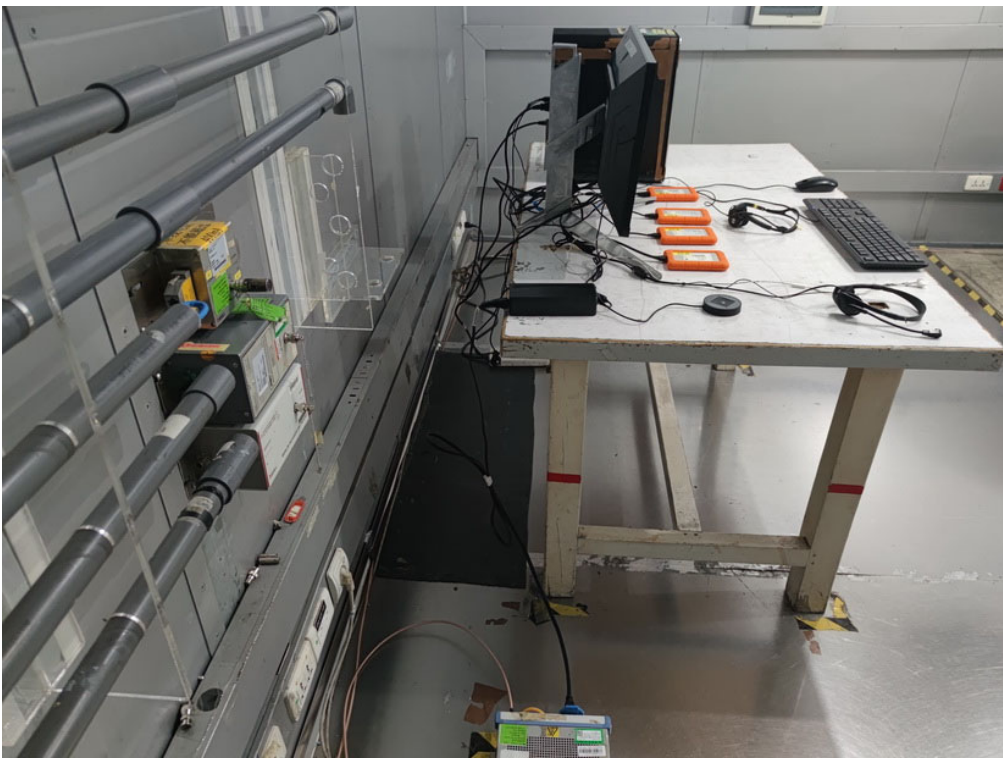

EN 55032:2015+AC:2016

Radiated emissions up to 1 GHz

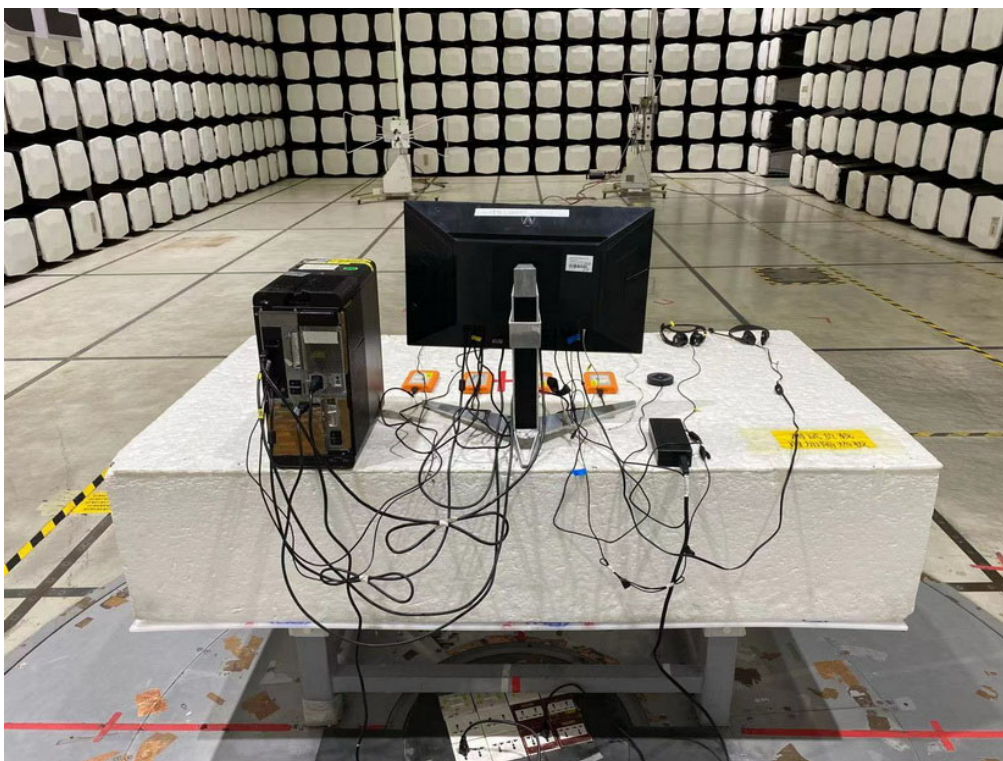
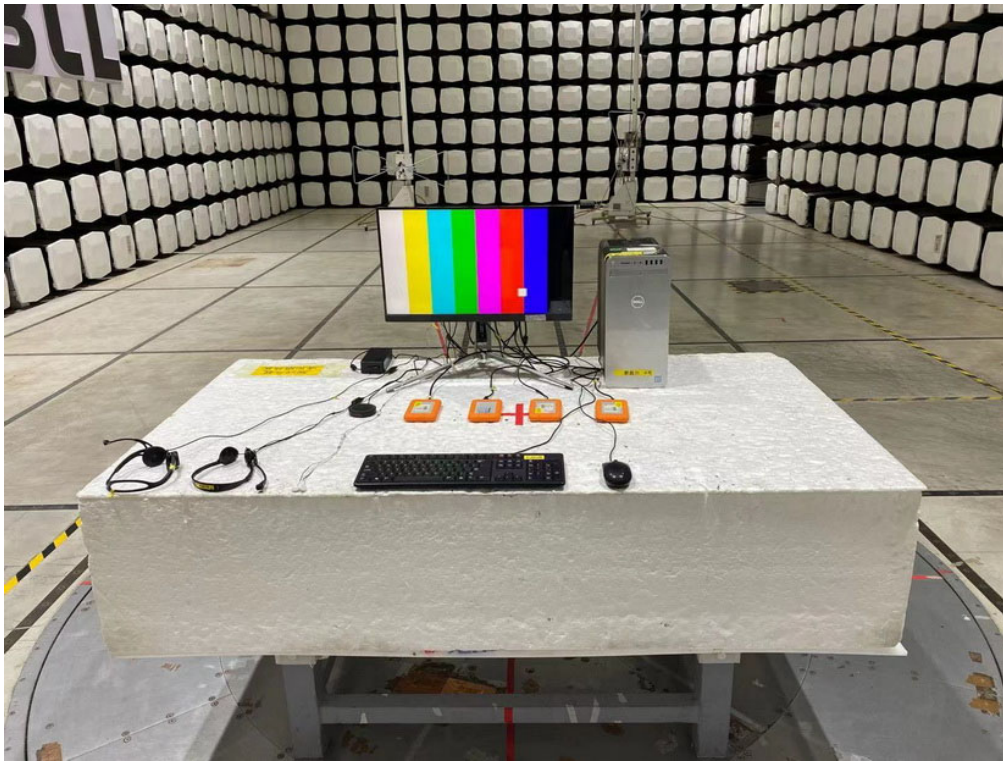

Radiated emissions above 1 GHz

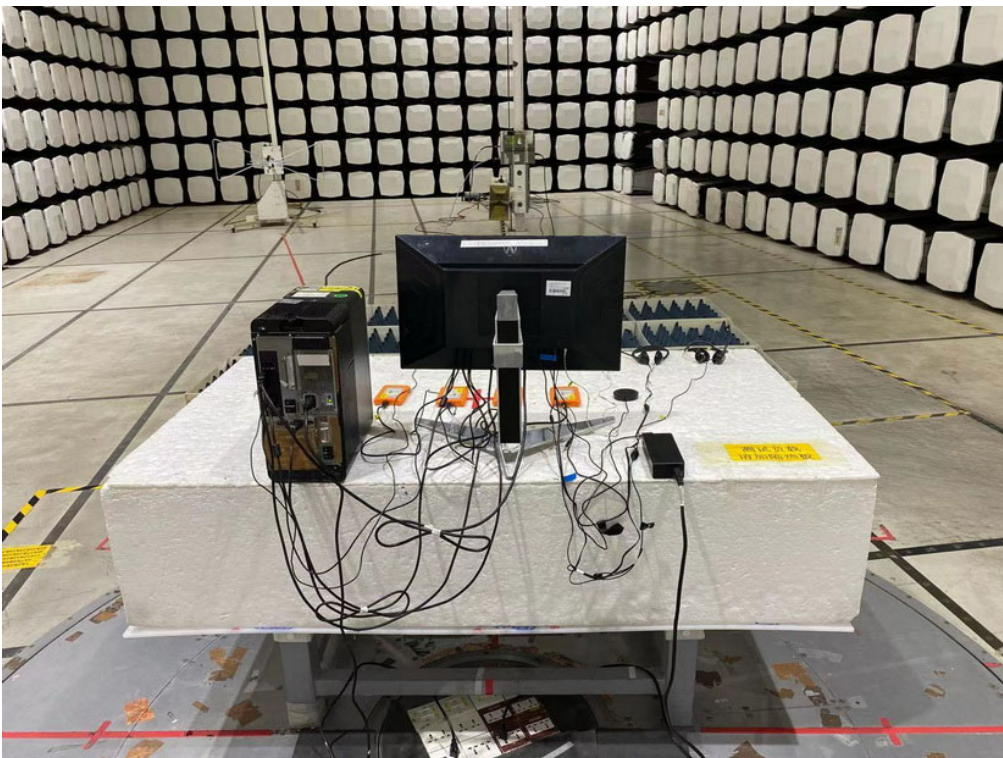
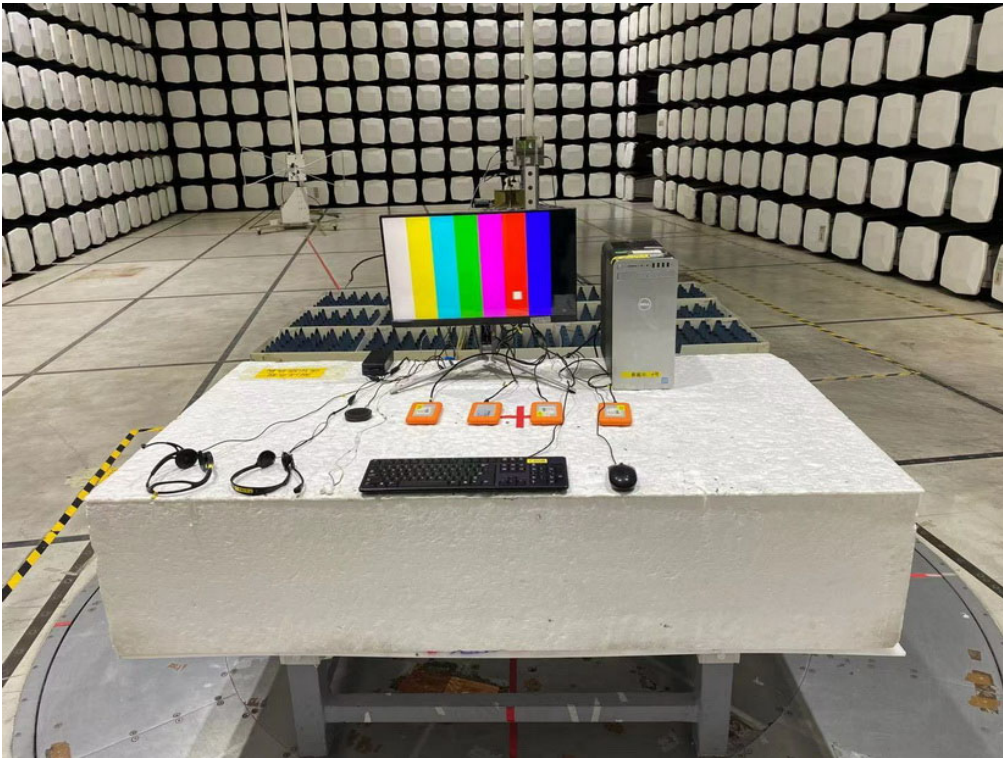

Conducted emissions AC mains power port

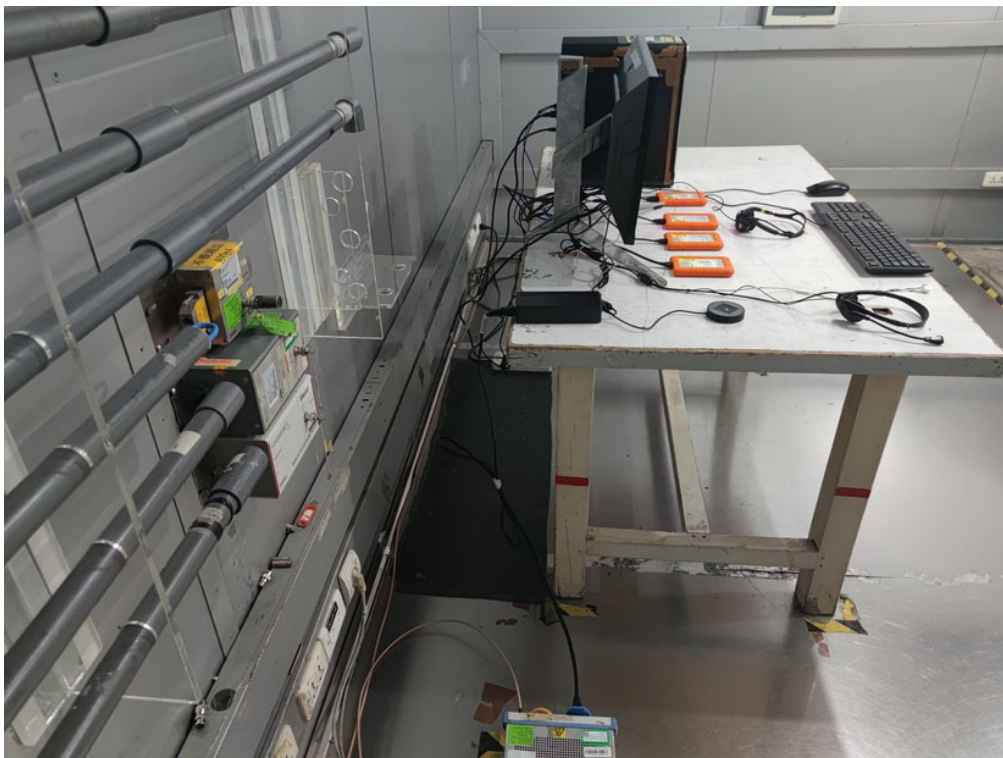

Harmonic current emissions

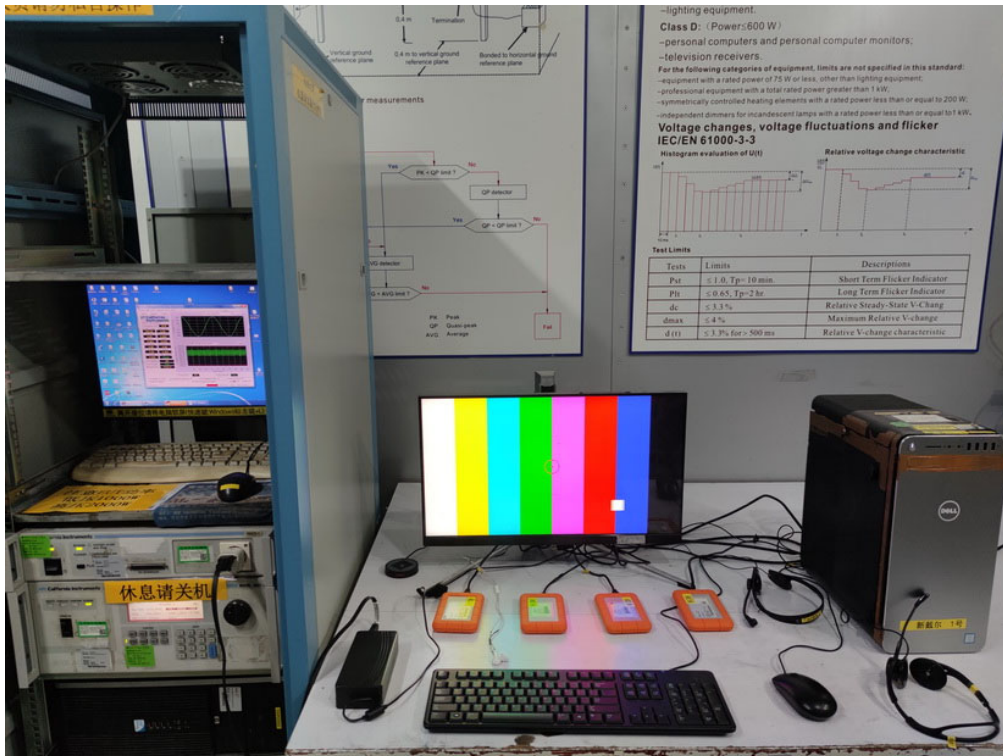

Voltage fluctuations (Flicker)



Electrostatic discharge immunity



Radiated, radio-frequency, electromagnetic field immunity – up to 1GHz



Radiated, radio-frequency, electromagnetic field immunity – above 1GHz



Electrical fast transient/burst immunity



Surge immunity



Immunity to conducted disturbances, induced by radio-frequency fields



Power frequency magnetic field immunity

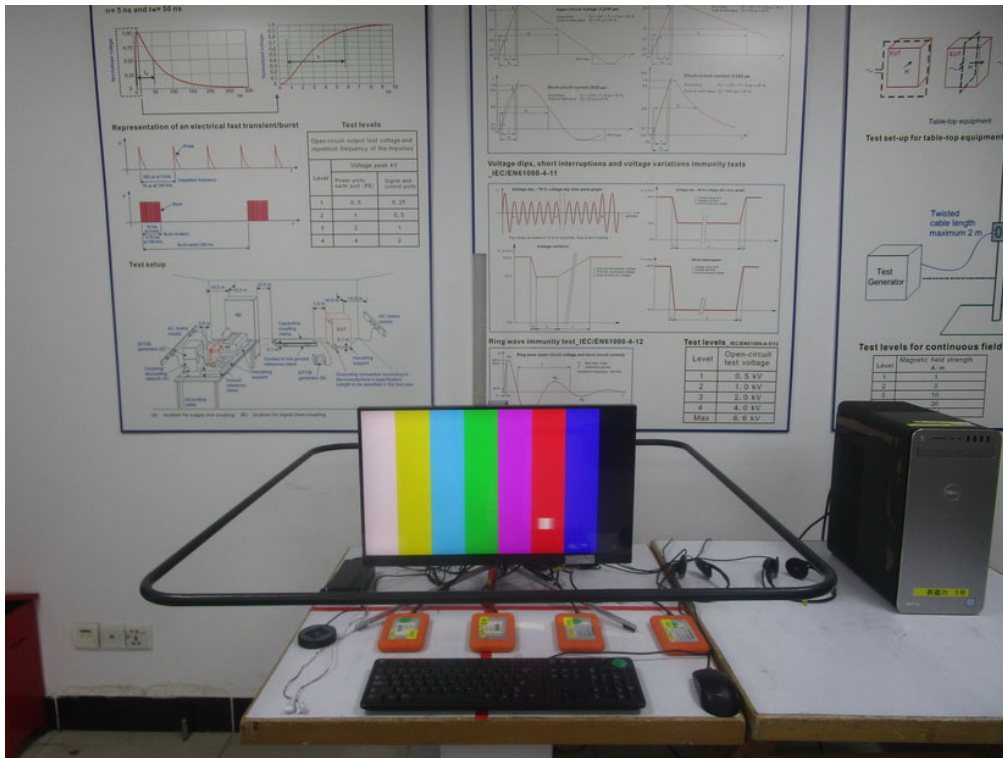

Voltage dips, short interruptions and voltage variations immunity



End of Test Report