

EMC TEST REPORT

For

Dongguan Lingjie Electronics & Technology Co., Ltd

Product Name:Gaming Mouse

Model No.: AGM600

Prepared for : Dongguan Lingjie Electronics & Technology Co., Ltd
Address : Building A(Floor 1-4) and B(Floor 1-5), No. 16 Zhenxing North Road, Taiyuan Community, Xiegang Town, Dongguan City, Guangdong Province, 523590, P.R.C.

Prepared by : SHENZHEN POCE TECHNOLOGY CO., LTD.
Address : 101-102 Building H1 & 1/F., Building H, Hongfa Science & Technology Park, Tangtou, Shiyan, Bao'an District, Shenzhen, Guangdong, China

Report No. : POCE220507006VRE
Date of Receiver : Apr. 29, 2022
Number of tested samples : 1
Date of Test : Apr. 29, 2022–May 07, 2022
Date of Report : May 07, 2022

Note: This test report is limited to the above client company and the product model only. It may not be duplicated without prior written consent of Shenzhen POCE Technology Co., Ltd

101-102 Building H5 & 1/F., Building H, Hongfa Science & Technology Park, Tangtou, Shiyan, Bao'an District, Shenzhen, Guangdong, China

Tel: +86-755-29113252 E-mail:service@poce-cert.com <http://www.poce-cert.com>

TABLE OF CONTENT

Description	Page
Test Report Description	
1. GENERAL INFORMATION	4
1.1. Description of Device (EUT).....	4
1.2. Test Standards	5
1.3. Test Methodology.....	5
1.4. Test Facility	5
2. MEASURING DEVICE AND TEST EQUIPMENT	6
2.1. For Power Line Conducted Emission	6
2.2. For Radiated Emission Measurement	6
2.3. For Harmonic Current / Flicker Measurement.....	6
2.4. For Electrostatic Discharge Immunity Test	6
2.5. For RF Strength Susceptibility Test.....	7
2.6. For Electrical Fast Transient /Burst Immunity Test.....	7
2.7. For Surge Immunity Test.....	7
2.8. For Injected Current Susceptibility Test.....	7
2.9. For Magnetic Field Immunity Test.....	7
2.10. For Voltage Dips and Interruptions Test.....	8
3. POWER LINE CONDUCTED EMISSION MEASUREMENT	9
3.1. Block Diagram of Test Setup.....	9
3.2. EUT Configuration on Measurement.....	9
3.3. Test Procedure	9
4. RADIATED EMISSION MEASUREMENT.....	11
4.1. Block Diagram of Test.....	11
4.2. Measuring Standard	11
4.3. EUT Configuration on Test.....	12
4.4. Test Procedure	12
5. HARMONIC CURRENT EMISSION MEASUREMENT.....	15
5.1 Block Diagram of Test Setup.....	15
5.2 Measuring Standard.....	15
5.3 Description of test Equipment.....	15
6. VOLTAGE FLUCTUATION AND FLICKER MEASUREMENT.....	16
6.1 Block Diagram of Test Setup.....	16
6.2 Measuring Standard	16
7. ELECTROSTATIC DISCHARGE IMMUNITY TEST	17
7.1 Block Diagram of Test Setup	17
7.2 Test Standard	17
7.3 Severity Levels and Performance Criterion	17
7.4 Test Procedure	18
8. RF FIELD STRENGTH SUSCEPTIBILITY TEST	20
8.1 Block Diagram of Test.....	20
8.2 Test Standard.....	20
8.3 Severity Levels and Performance Criterion.....	21
8.4 Test Procedure	21
9. ELECTRICAL FAST TRANSIENT/BURST IMMUNITY TEST	23
9.1 Block Diagram of Test Setup	23
9.2 Test Standard	23
9.3 Severity Levels and Performance Criterion	23

9.4 Test Procedure	24
Note: N/A denotes test is not applicable in this test report.....	24
10. SURGE IMMUNITY TEST.....	25
10.1 Block Diagram of Test Setup	25
10.2 Test Standard	25
10.3 Severity Levels and Performance Criterion	25
10.4 Test Procedure	26
Note: N/A denotes test is not applicable in this test report.....	26
11. INJECTED CURRENTS SUSCEPTIBILITY TEST	27
11.1 Block Diagram of Test Setup.....	27
11.2 Test Standard	27
11.3 Severity Levels and Performance Criterion.....	27
11.4 Test Procedure	28
Note: N/A denotes test is not applicable in this test report.....	28
12. MAGNETIC FIELD SUSCEPTIBILITY TEST	29
12.1 Block Diagram of Test	29
12.2 Test Standard	29
12.3 Severity Levels and Performance Criterion	29
12.4 Test Procedure	29
13. VOLTAGE DIPS AND INTERRUPTIONS TEST	31
13.1 Block Diagram of Test Setup	31
13.2 Test Standard	31
13.3 Severity Levels and Performance Criterion	32
13.4 Test Procedure	32
Note: N/A denotes test is not applicable in this test report.....	32
14. PHOTOGRAPH	33
14.1 Photo of Radiated Emission	33
15. PHOTOGRAPHS OF EUT.....	34

1. GENERAL INFORMATION

1.1. Description of Device (EUT)

EUT : Gaming Mouse

Trade Mark : AOC

Model : AGM600

Supplementary Model(s) : AGM6***** (*=A~Z,a~z,0~9,/,or blank)

Test Voltage : DC 5V

Rating : Input: DC 5 V, 120MA

Applicant : Dongguan Lingjie Electronics & Technology Co., Ltd

Address : Building A(Floor 1-4) and B(Floor 1-5), No. 16 Zhenxing North Road, Taiyuan Community, Xiegang Town, Dongguan City, Guangdong Province, 523590, P.R.C.

Manufacturer : TPV Electronics (Fujian) Co., Ltd.

Address : Rongqiao Economic and Technological Development Zone, Fuqing City, Fujian Province, P.R.China

Test Standards : EN 55032:2015/A11:2020
EN 55035:2017/A11:2020
EN IEC 61000-3-2:2019/A1:2021
EN 61000-3-3:2013/A1:2019

Test Result : PASS

Test Engineer :

Reviewed By :



1.2. Test Standards

Standard	Test Items	Test Results
EN 55032:2015/A11:2020	Power Line Conducted Emission Test (150KHz To 30MHz)	N/A
	Radiated Emission(30MHz To 1000MHz)	PASS
	Radiated Emission(1GHz To 6GHz)	N/A
EN IEC 61000-3-2:2019/A1:2021	Harmonic Current	N/A
EN 61000-3-3:2013+A1:2019	Voltage Fluctuation And Flicker	N/A
EN 61000-4-2:2009	Electrostatic Discharge Immunity	PASS
EN 61000-4-3:2006+A2:2010	Radiated Electromagnetic Fields Immunity (80MHz to 1GHz)	PASS
	Radiated Electromagnetic Fields Immunity (1800MHz to 5GHz)	PASS
EN 61000-4-4:2012	Electric Fast Transient Burst Immunity	N/A
EN 61000-4-5:2014+A1:2017	Surge Immunity	N/A
EN 61000-4-6:2014+AC:2015	Injected Currents Susceptibility Test	N/A
EN 61000-4-8:2010	Magnetic field susceptibility test	PASS
EN 61000-4-11:2004+A1:2017	Voltage Dips And Interruptions Immunity	N/A

Note: Pass Indicates that the test is applicable
 N/A Indicates that the test is not applicable

1.3. Test Methodology

All measurements contained in this report were conducted with CISPR 16-1, radio disturbance and immunity measuring apparatus, and CISPR 16-2, Method of measurement of disturbances and immunity.

All measurement required was performed at laboratory of Shenzhen POCE Technology Co., Ltd., at 101-102 Building H5 & 1/F., Building H, Hongfa Science & Technology Park, Tangtou, Shiyuan, Bao'an District, Shenzhen, Guangdong, China

1.4. Test Facility

The test facility is recognized, certified, or accredited by the following organizations:

The facility also complies with the radiated and AC line conducted test site criteria set forth in CISPR 16-1, CISPR 16-2.

2. MEASURING DEVICE AND TEST EQUIPMENT

2.1. For Power Line Conducted Emission

Item	Equipment	Manufacturer	Model No.	Factory Number	Last Cal.
1.	Test Receiver	Rohde & Schwarz	ESPI TEST RECEIVER	ID:1164.6607K03-102109-MH	Dec. 27, 2021
2.	L.I.S.N	Rohde & Schwarz	ESH3-Z5.831.5518.52	9561-G071	Dec. 27, 2021
3.	50ΩCoaxial Switch	Anritsu	MP59B	M20531	N/A
4.	Pulse Limiter	SCHWARZ BECK	VTSD 9561-F Pulse limiter 10dB Ateennator	561-G071	Dec. 27, 2021
5.	Cable	SCHWARZ BECK	N/A	N/A	Dec. 27, 2021

2.2. For Radiated Emission Measurement

Item	Equipment	Manufacturer	Model No.	Factory Number	Last Cal.
1.	Test Receiver	Rohde & Schwarz	ESPI TEST RECEIVER	ID:1164.6607K03-102109-MH	Dec. 27, 2021
2.	Bilog Antenna	Sunol Sciences	Model JB6 Antenna	A090414	Dec. 27, 2021
3.	50ΩCoaxial Switch	Anritsu	MP59B	M20531	N/A
4.	control	Positioning Controller	Model MF-7802	MF780208362	Dec. 27, 2021
5.	Cable	SCHWARZ BECK	N/A	N/A	Dec. 27, 2021
6.	Cable	SCHWARZ BECK	N/A	N/A	Dec. 27, 2021
7.	PC	HP	HP 285G2	2XR63PA#AB2	N/A
8.	keyboard	A4TECH	KB-8	Z190KB8U	N/A
9.	Mouse	DELL	MS111-P	N/A	N/A
10.	monitor	LG	24MP55VA	503NDPH7T144	N/A
11.	notebook	Tongfang Co., Ltd.	Z2 Air-s	421026H32110570987	WIN10

2.3. For Harmonic Current / Flicker Measurement

Item	Equipment	Manufacturer	Model No.	Factory Number	Last Cal.
1.	Coupling decoupling network	SCHAFFNER	M016	20812	Dec. 27, 2021
2.	PC	N/A	P2L97	N/A	Dec. 27, 2021

2.4. For Electrostatic Discharge Immunity Test

Item	Equipment	Manufacturer	Model No.	Factory Number	Last Cal.
------	-----------	--------------	-----------	----------------	-----------

1.	ESD Tester	Prima	ESD61002A	144305	Dec. 27, 2021
----	------------	-------	-----------	--------	---------------

2.5. For RF Strength Susceptibility Test

Item	Equipment	Manufacturer	Model No.	Factory Number	Last Cal.
1.	Signal Generator	HP	8648A	3625U00573	Dec. 27, 2021
2.	Amplifier	AR	500A100	17034	NCR
3.	Amplifier	AR	100W/1000M1	17028	NCR
4.	Isotropic Field Monitor	AR	FM2000	16829	NCR
5.	Isotropic Field Probe	AR	FP2000	16755	Dec. 27, 2021
6.	Biconic Antenna	EMCO	3108	9507-2534	NCR
7.	Log-periodic Antenna	AR	AT1080	16812	NCR
8.	PC	N/A	486DX2	N/A	N/A

2.6. For Electrical Fast Transient /Burst Immunity Test

Item	Equipment	Manufacturer	Model No.	Factory Number	Last Cal.
1.	Burst Tester	HTEC	HEFT 51	144303	Dec. 27, 2021
2.	Coupling Clamp	HTEC	IP-4A	147147	Dec. 27, 2021

2.7. For Surge Immunity Test

Item	Equipment	Manufacturer	Model No.	Factory Number	Last Cal.
1.	Surge Tester	HTEC	HCWG	144302	Dec. 27, 2021

2.8. For Injected Current Susceptibility Test

Item	Equipment	Manufacturer	Model No.	Factory Number	Last Cal.
1.	Simulator	EMTEST	CWS500C	0900-12	Dec. 27, 2021
2.	CDN	EMTEST	CDN-M2	5100100100	Dec. 27, 2021
3.	CDN	EMTEST	CDN-M3	0900-11	Dec. 27, 2021
4.	Injection Clamp	EMTEST	F-2031-23MM	368	Dec. 27, 2021
5.	Attenuator	EMTEST	ATT6	0010222A	Dec. 27, 2021

2.9. For Magnetic Field Immunity Test

Item	Equipment	Manufacturer	Model No.	Factory Number	Last Cal.
1.	Magnetic Field Tester	HTEC	HPFM T	144301	Dec. 27, 2021

2.10. For Voltage Dips and Interruptions Test

Item	Equipment	Manufacturer	Model No.	Factory Number	Last Cal.
1.	Dips Tester	HTEC	HPFS	144304	Dec. 27, 2021

3. POWER LINE CONDUCTED EMISSION MEASUREMENT

3.1. Block Diagram of Test Setup

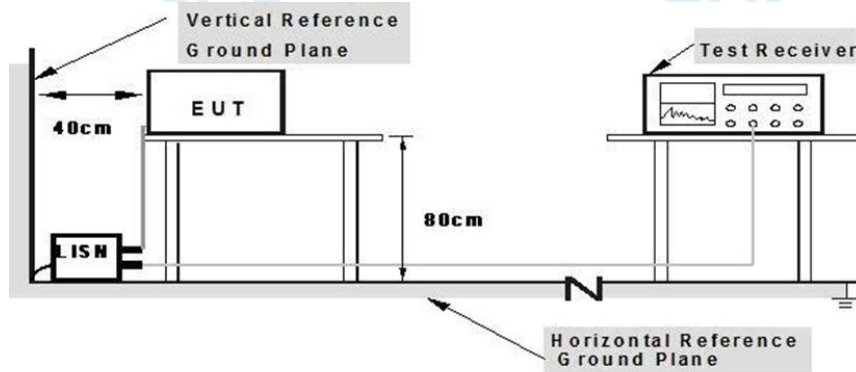

**Note: 1. Support units were connected to second LISN.
2. Both of LISNs (AMN) are 80 cm from EUT and at least 80 from other units and other metal planes**

Measuring Standard
EN 55032:2015/A11:2020

Power Line Conducted Emission Limits (Class B)

Frequency (MHz)	Limit (dB μ V)	
	Quasi-Peak Level	Average Level
0.15 ~ 0.50	66.0 ~ 56.0 *	56.0 ~ 46.0 *
0.50 ~ 5.00	56.0	46.0
5.00 ~ 30.00	60.0	50.0

NOTE1-The lower limit shall apply at the transition frequencies.
NOTE2-The limit decreases linearly with the logarithm of the frequency in the range 0.15MHz to 0.50MHz.

3.2. EUT Configuration on Measurement

The following equipments are installed on Conducted Emission Measurement to meet EN55032 requirements and operating in a manner which tends to maximize its emission characteristics in a normal application.

3.3. Test Procedure

The EUT is put on the plane 0.8m high above the ground by insulating support and connected to the AC mains through Line Impedance Stability Network (L.I.S.N). This provided a 50ohm coupling impedance for the tested equipments. Both sides of AC line are investigated to find out the maximum conducted emission according to the EN55032 regulations during conducted

101-102 Building H5 & 1/F., Building H, Hongfa Science & Technology Park, Tangtou, Shiyuan, Bao'an District, Shenzhen, Guangdong, China

Tel: +86-755-29113252 E-mail: service@poce-cert.com http://www. poce-cert.com

emission measurement.

The bandwidth of the field strength meter (R&S Test Receiver ESCI3) is set at 9KHz in 150KHz~30MHz and 200Hz in 9KHz~150KHz.

The frequency range from 150kHz to 30MHz is investigated.

Conduction Uncertainty: $U_c = \pm 2.72 \text{ Db}$

Note: 1. N/A denotes test is not applicable in this test report.

2. There was not any unintentional transmission in standby mode.

4. RADIATED EMISSION MEASUREMENT

4.1. Block Diagram of Test

4.1.1. Block diagram of test setup (In chamber)

1. Radiated Emission Test Set-Up Frequency Below 1000MHz

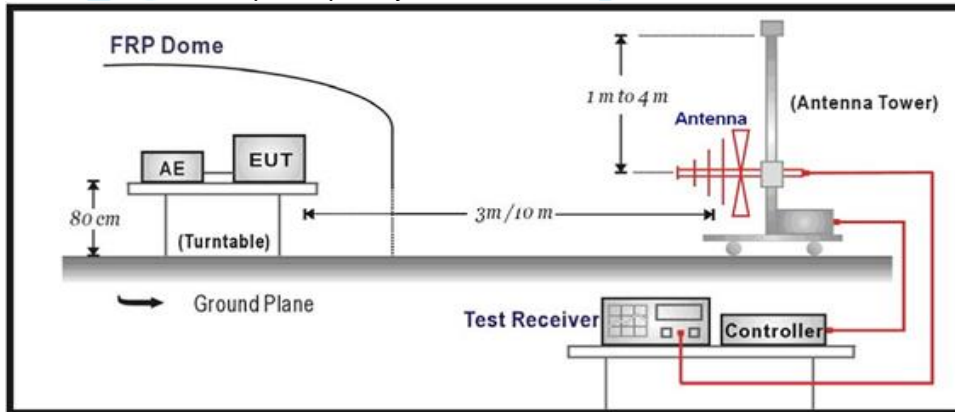

2. Radiated Emission Test Set-Up Frequency Above 1000MHz

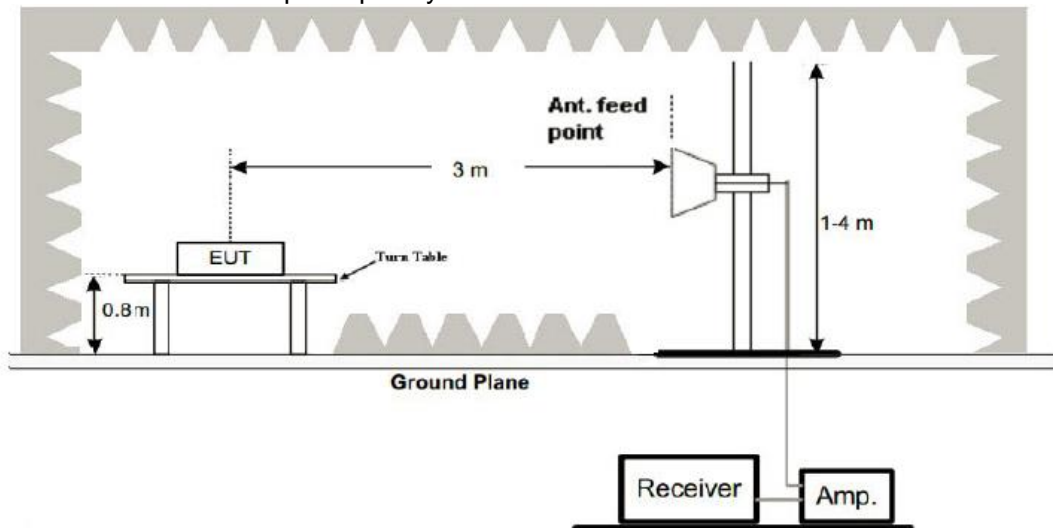

4.2. Measuring Standard

EN 55032:2015/A11:2020

Radiated Emission Limits

All emanations from a class B device or system, including any network of conductors and apparatus connected thereto, shall not exceed the level of field strengths specified below:

LIMITS OF RADIATED EMISSION MEASUREMENT (Below 1000MHz)

FREQUENCY (MHz)	DISTANCE (Meters)	FIELD STRENGTHS LIMIT (dB μ V/m)
30 ~ 230	3	40
230 ~ 1000	3	47

Note: (1) The smaller limit shall apply at the combination point between two frequency

101-102 Building H5 & 1/F., Building H, Hongfa Science & Technology Park, Tangtou, Shiyao, Bao'an District, Shenzhen, Guangdong, China

Tel: +86-755-29113252

E-mail: service@poc-cert.com

http://www.poc-cert.com

bands.

- (2) Distance refers to the distance in meters between the measuring instrument antenna and the closed point of any part of the EUT.

LIMITS OF RADIATED EMISSION MEASUREMENT(Above 1000MHz)

FREQUENCY (MHz)	DISTANCE (Meters)	FIELD STRENGTHS LIMIT (dB μ V/m)	
		Peak	Avg
1000 ~ 6000	3	74	54

4.3.EUT Configuration on Test

The EN55032 regulations test method must be used to find the maximum emission during radiated emission measurement.

4.4.Test Procedure

1. The EUT was placed 0.4 meters from the horizontal ground plane with EUT being connected to the power mains through a line impedance stabilization network (LISN). All other support equipments powered from additional LISN(s). The LISN provide 50 Ohm/ 50uH of coupling impedance for the measuring instrument.

2. Interconnecting cables that hang closer than 40 cm to the ground plane shall be folded back and forth in the center forming a bundle 30 to 40 cm long.

3. I/O cables that are not connected to a peripheral shall be bundled in the center. The end of the cable may be terminated, if required, using the correct terminating impedance. The overall length shall not exceed 1 m.

The EUT is placed on a turn table which is 0.8 meter high above the ground. The turn table can rotate 360 degrees to determine the position of the maximum emission level. The EUT is set 3 meters away from the receiving antenna which is mounted on a antenna tower. The antenna can be moved up and down from 1 to 4 meters to find out the maximum emission level. Bilog antenna (calibrated by Dipole Antenna) is used as a receiving antenna. Both horizontal and vertical polarization of the antenna are set on test.

The bandwidth of the Receiver (ESCI3) is set at 120kHz. 1 MHz for measuring above 1 GHz, The frequency range from 30MHz to 1000MHz is investigated.

Radiation Uncertainty: $U_r = \pm 3.84$ dB

Below 1000MHz Test Results:

Radiated Emission Test Data

EUT	: Gaming Mouse	Temperature:	20°C
M/N	: AGM600	Humidity	: 50%
Test Voltage	: DC 5V	Test Mode	: On
Test Engineer	: Bill	Polarization	: Horizontal

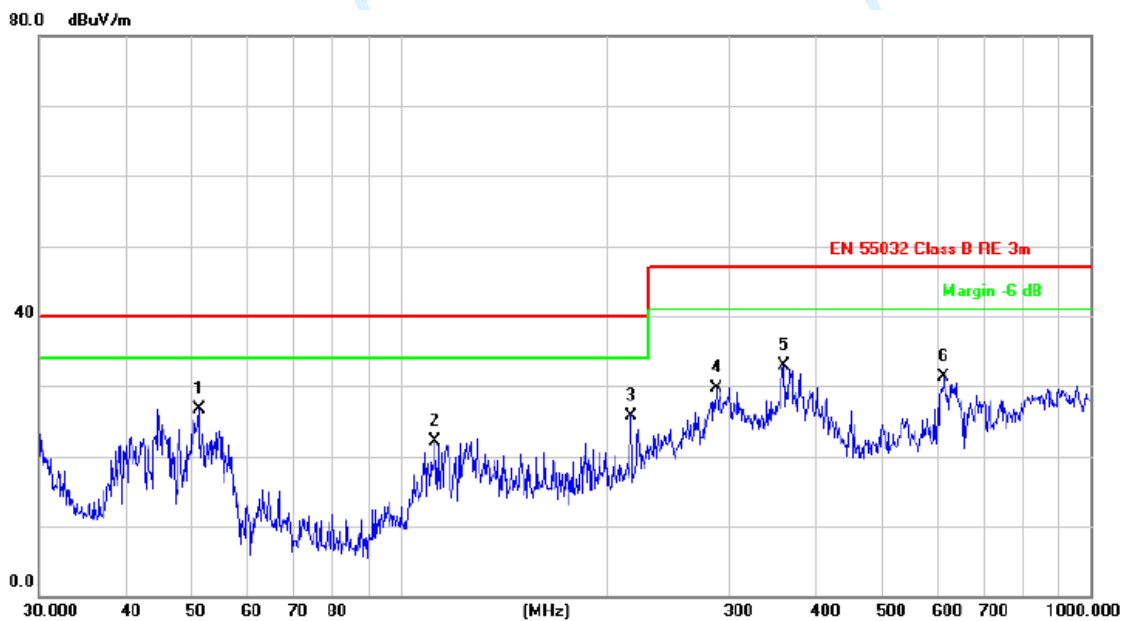

No.	Mk.	Freq. MHz	Reading Level dBuV	Correct Factor dB/m	Measure- ment dBuV/m	Limit dBuV/m	Over dB	Antenna Height cm	Table Degree degree	Comment
1	*	51.1209	41.09	-14.43	26.66	40.00	-13.34	QP		
2		112.5244	28.29	-6.19	22.10	40.00	-17.90	QP		
3		216.0240	32.75	-7.11	25.64	40.00	-14.36	QP		
4		287.9904	33.97	-4.26	29.71	47.00	-17.29	QP		
5		360.4476	35.61	-2.73	32.88	47.00	-14.12	QP		
6		614.2142	30.73	0.53	31.26	47.00	-15.74	QP		

Remark: Absolute Level = Reading Level + Factor, Margin = Absolute Level – Limit
 Factor = Ant. Factor + Cable Loss – Pre-amplifier

Radiated Emission Test Data

EUT	: Gaming Mouse	Temperature:	20°C
M/N	: AGM600	Humidity	: 50%
Test Voltage	: DC 5V	Test Mode	: On
Test Engineer	: Bill	Polarization	: Vertical

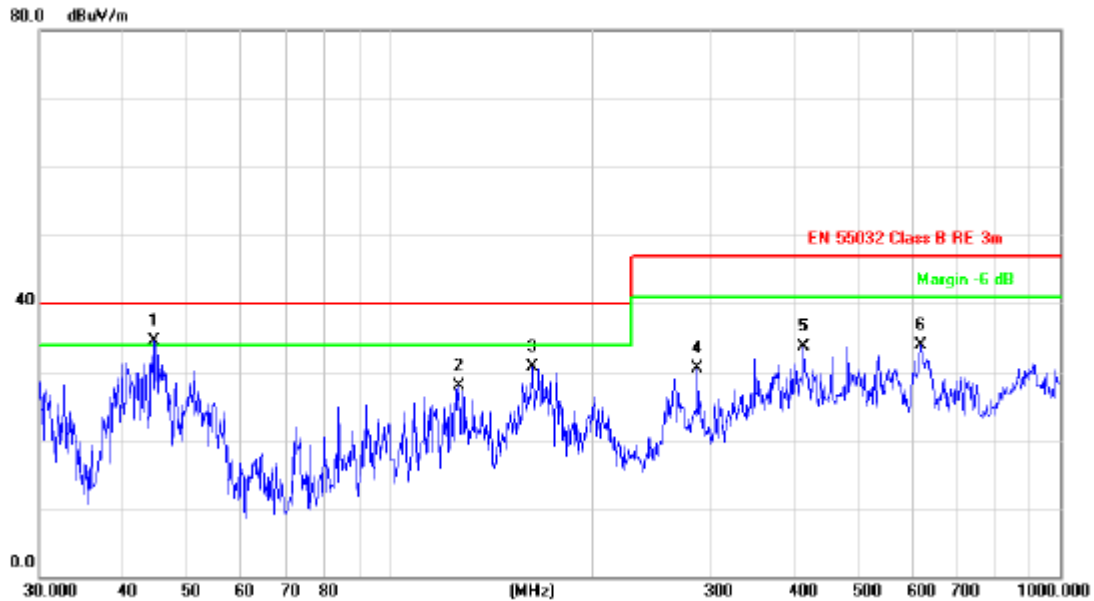

No.	Mk.	Freq.	Reading Level	Correct Factor	Measurement	Limit	Over	Antenna Height	Table Degree	
		MHz	dBuV	dB/m	dBuV/m	dBuV/m	dB	cm	degree	Comment
1	*	44.5868	46.63	-12.14	34.49	40.00	-5.51	QP		
2		126.7723	33.10	-5.28	27.82	40.00	-12.18	QP		
3		163.1818	36.51	-5.88	30.63	40.00	-9.37	QP		
4		287.9904	34.76	-4.26	30.50	47.00	-16.50	QP		
5		414.7223	35.00	-1.30	33.70	47.00	-13.30	QP		
6		618.5369	33.52	0.48	34.00	47.00	-13.00	QP		

Remark: Absolute Level = Reading Level + Factor, Margin = Absolute Level – Limit
 Factor = Ant. Factor + Cable Loss – Pre-amplifier

Above 1 GHz Test Results: N/A

5. HARMONIC CURRENT EMISSION MEASUREMENT

5.1 Block Diagram of Test Setup

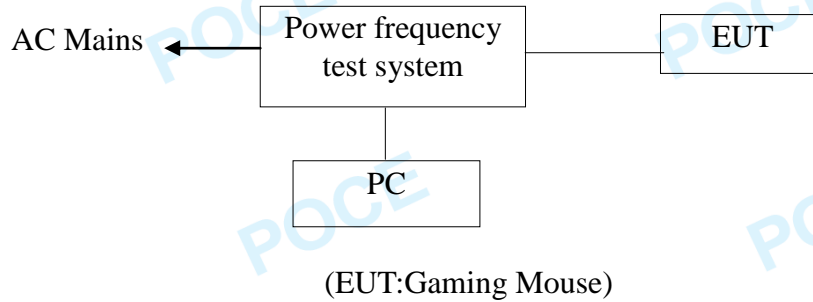

5.2 Measuring Standard

EN IEC 61000-3-2:2019/A1:2021

5.3 Description of test Equipment

Note: The equipment is less than 75W and has no corresponding harmonic current.

1. N/A denotes test is not applicable in this test report.
2. There was not any unintentional transmission in standby mode.

6. VOLTAGE FLUCTUATION AND FLICKER MEASUREMENT

6.1 Block Diagram of Test Setup

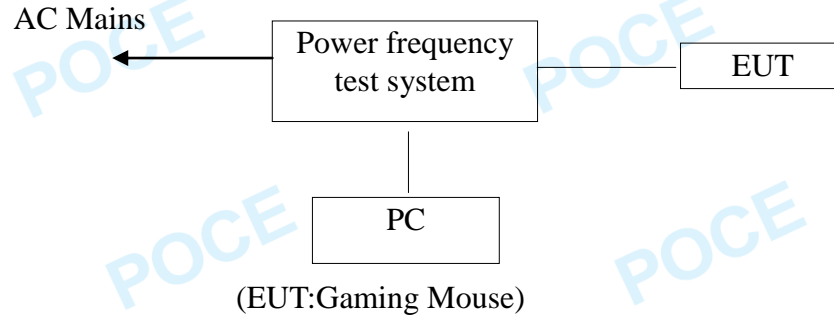

6.2 Measuring Standard

EN 61000-3-3:2013/A1:2019

Note: 1. N/A denotes test is not applicable in this test report.

2. There was not any unintentional transmission in standby mode.

7. ELECTROSTATIC DISCHARGE IMMUNITY TEST

7.1 Block Diagram of Test Setup

7.1.1 Block Diagram of the EUT and the simulators

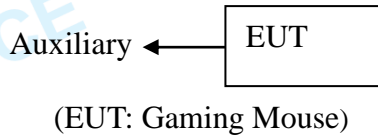

7.1.2 Block diagram of ESD test setup

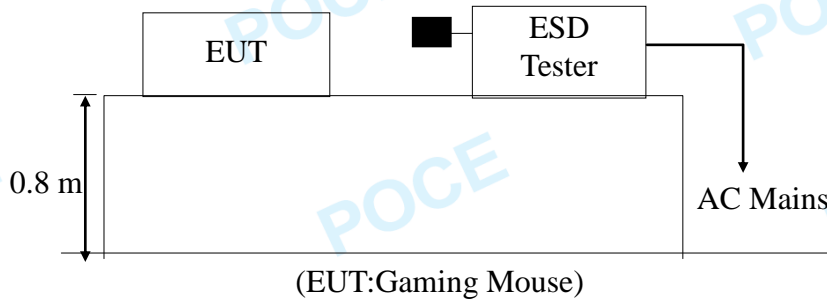

7.2 Test Standard

EN 55035:2017/A11:2020 (EN61000-4-2: 2009)

Severity Level: 3 / Air Discharge: $\pm 8\text{KV}$ Level: 2 / Contact Discharge: $\pm 4\text{KV}$

7.3 Severity Levels and Performance Criterion

7.3.1 Severity level

Level	Test Voltage Contact Discharge (KV)	Test Voltage Air Discharge (KV)
1.	± 2	± 2
2.	± 4	± 4
3.	± 6	± 8
4.	± 8	± 15
X	Special	Special

7.3.2 Performance criterion: **B**

7.4 Test Procedure

7.4.1 Air Discharge:

This test is done on a non-conductive surface. The round discharge tip of the discharge electrode shall be approached as fast as possible to touch the EUT. After each discharge, the discharge electrode shall be removed from the EUT. The generator is then re-triggered for a new single discharge and repeated 10 times for each pre-selected test point. This procedure shall be repeated until all the air discharge completed.

7.4.2 Contact Discharge:

All the procedure shall be same as Section 7.4.1. except that the tip of the discharge electrode shall touch the EUT before the discharge switch is operated.

7.4.3 Indirect discharge for horizontal coupling plane

At least 10 single discharges (in the most sensitive polarity) shall be applied at the front edge of each HCP opposite the center point of each unit (if applicable) of the EUT and 0.1m from the front of the EUT. The long axis of the discharge electrode shall be in the plane of the HCP and perpendicular to its front edge during the discharge.

7.4.4 Indirect discharge for vertical coupling plane

At least 10 single discharge (in the most sensitive polarity) shall be applied to the center of one vertical edge of the coupling plane. The coupling plane, of dimensions 0.5m X 0.5m, is placed parallel to, and positioned at a distance of 0.1m from the EUT. Discharges shall be applied to the coupling plane, with this plane in sufficient different positions that the four faces of the EUT are completely illuminated.

Electrostatic Discharge Test Results

Standard	<input type="checkbox"/> IEC 61000-4-2 <input checked="" type="checkbox"/> EN 61000-4-2		
EUT	Gaming Mouse	Temperature	24°C
M/N	AGM600	Humidity	53%
Criterion	B	Pressure	1021mbar
Test Mode	Normal	Test Date	2022-05-05
Test Engineer	Bill		

Air Discharge

Test Points	Test Levels			Results		
	± 2KV	± 4KV	± 8KV	Passed	Fail	Performance Criterion
Front	<input checked="" type="checkbox"/>	<input checked="" type="checkbox"/>	<input checked="" type="checkbox"/>	<input checked="" type="checkbox"/>	<input type="checkbox"/>	<input type="checkbox"/> A <input checked="" type="checkbox"/> B
Back	<input checked="" type="checkbox"/>	<input checked="" type="checkbox"/>	<input checked="" type="checkbox"/>	<input checked="" type="checkbox"/>	<input type="checkbox"/>	<input type="checkbox"/> A <input checked="" type="checkbox"/> B
Left	<input checked="" type="checkbox"/>	<input checked="" type="checkbox"/>	<input checked="" type="checkbox"/>	<input checked="" type="checkbox"/>	<input type="checkbox"/>	<input type="checkbox"/> A <input checked="" type="checkbox"/> B
Right	<input checked="" type="checkbox"/>	<input checked="" type="checkbox"/>	<input checked="" type="checkbox"/>	<input checked="" type="checkbox"/>	<input type="checkbox"/>	<input type="checkbox"/> A <input checked="" type="checkbox"/> B
Top	<input checked="" type="checkbox"/>	<input checked="" type="checkbox"/>	<input checked="" type="checkbox"/>	<input checked="" type="checkbox"/>	<input type="checkbox"/>	<input type="checkbox"/> A <input checked="" type="checkbox"/> B
Bottom	<input checked="" type="checkbox"/>	<input checked="" type="checkbox"/>	<input checked="" type="checkbox"/>	<input checked="" type="checkbox"/>	<input type="checkbox"/>	<input type="checkbox"/> A <input checked="" type="checkbox"/> B

Contact Discharge

Test Points	Test Levels		Results		
	± 2 kV	±4 kV	Passed	Fail	Performance Criterion
Front	<input checked="" type="checkbox"/>	<input checked="" type="checkbox"/>	<input checked="" type="checkbox"/>	<input type="checkbox"/>	<input type="checkbox"/> A <input checked="" type="checkbox"/> B
Back	<input checked="" type="checkbox"/>	<input checked="" type="checkbox"/>	<input checked="" type="checkbox"/>	<input type="checkbox"/>	<input type="checkbox"/> A <input checked="" type="checkbox"/> B
Left	<input checked="" type="checkbox"/>	<input checked="" type="checkbox"/>	<input checked="" type="checkbox"/>	<input type="checkbox"/>	<input type="checkbox"/> A <input checked="" type="checkbox"/> B
Right	<input checked="" type="checkbox"/>	<input checked="" type="checkbox"/>	<input checked="" type="checkbox"/>	<input type="checkbox"/>	<input type="checkbox"/> A <input checked="" type="checkbox"/> B
Top	<input checked="" type="checkbox"/>	<input checked="" type="checkbox"/>	<input checked="" type="checkbox"/>	<input type="checkbox"/>	<input type="checkbox"/> A <input checked="" type="checkbox"/> B
Bottom	<input checked="" type="checkbox"/>	<input checked="" type="checkbox"/>	<input checked="" type="checkbox"/>	<input type="checkbox"/>	<input type="checkbox"/> A <input checked="" type="checkbox"/> B

Discharge To Horizontal Coupling Plane

Side of EUT	Test Levels		Results		
	± 2 kV	± 4 kV	Passed	Fail	Performance Criterion
Front	<input checked="" type="checkbox"/>	<input checked="" type="checkbox"/>	<input checked="" type="checkbox"/>	<input type="checkbox"/>	<input type="checkbox"/> A <input checked="" type="checkbox"/> B
Back	<input checked="" type="checkbox"/>	<input checked="" type="checkbox"/>	<input checked="" type="checkbox"/>	<input type="checkbox"/>	<input type="checkbox"/> A <input checked="" type="checkbox"/> B
Left	<input checked="" type="checkbox"/>	<input checked="" type="checkbox"/>	<input checked="" type="checkbox"/>	<input type="checkbox"/>	<input type="checkbox"/> A <input checked="" type="checkbox"/> B
Right	<input checked="" type="checkbox"/>	<input checked="" type="checkbox"/>	<input checked="" type="checkbox"/>	<input type="checkbox"/>	<input type="checkbox"/> A <input checked="" type="checkbox"/> B

Discharge To Vertical Coupling Plane

Side of EUT	Test Levels		Results		
	± 2 kV	± 4 kV	Passed	Fail	Performance Criterion
Front	<input checked="" type="checkbox"/>	<input checked="" type="checkbox"/>	<input checked="" type="checkbox"/>	<input type="checkbox"/>	<input type="checkbox"/> A <input checked="" type="checkbox"/> B
Back	<input checked="" type="checkbox"/>	<input checked="" type="checkbox"/>	<input checked="" type="checkbox"/>	<input type="checkbox"/>	<input type="checkbox"/> A <input checked="" type="checkbox"/> B
Left	<input checked="" type="checkbox"/>	<input checked="" type="checkbox"/>	<input checked="" type="checkbox"/>	<input type="checkbox"/>	<input type="checkbox"/> A <input checked="" type="checkbox"/> B
Right	<input checked="" type="checkbox"/>	<input checked="" type="checkbox"/>	<input checked="" type="checkbox"/>	<input type="checkbox"/>	<input type="checkbox"/> A <input checked="" type="checkbox"/> B

8. RF FIELD STRENGTH SUSCEPTIBILITY TEST

8.1 Block Diagram of Test

8.1.1 Block diagram of connection between the EUT and Load

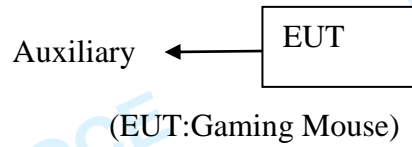

8.1.2 Block diagram of RS test setup

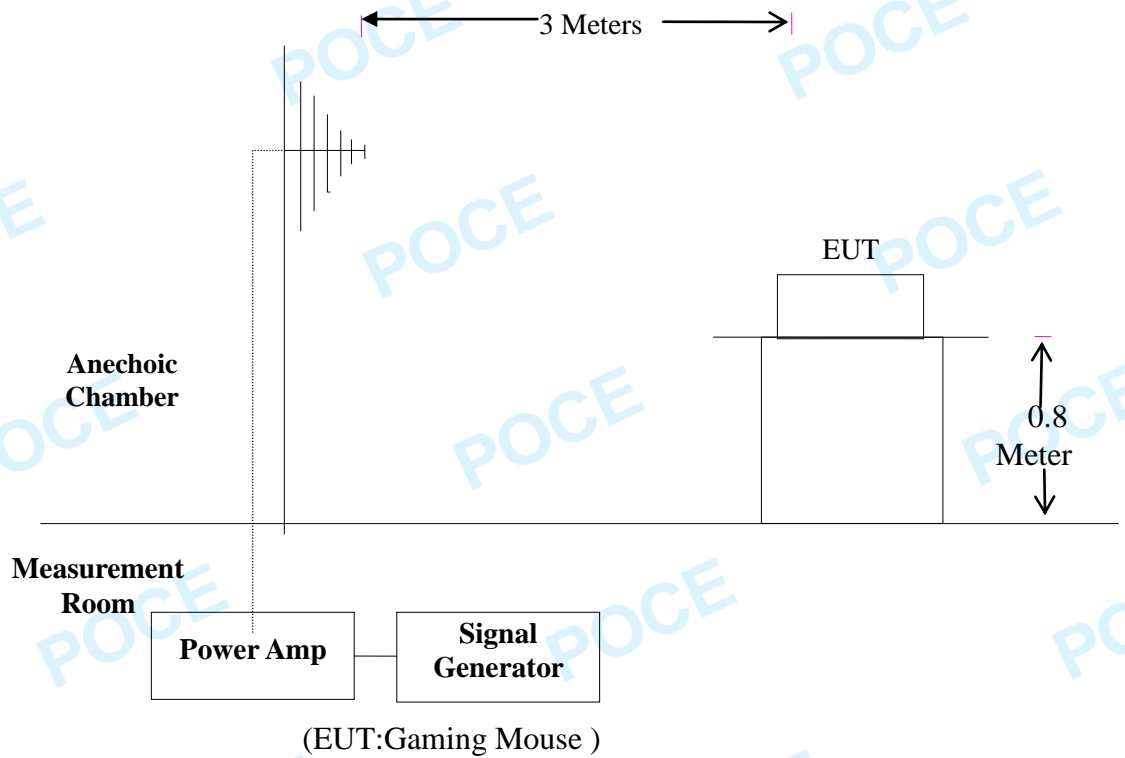

8.2 Test Standard

EN 55035:2017/A11:2020 (EN 61000-4-3:2006+A2:2010)

Severity Level 2 at 3V / m

8.3 Severity Levels and Performance Criterion

8.3.1 Severity Levels

Level	Field Strength V/m
1.	1
2.	3
3.	10
X	Special

8.3.2 Performance Criterion : A

8.4 Test Procedure

The EUT are placed on a table which is 0.8 meter high above the ground. The EUT is set 3 meters away from the transmitting antenna which is mounted on an antenna tower. Both horizontal and vertical polarization of the antenna are set on test. Each of the four sides of the EUT must be faced this transmitting antenna and measured individually. In order to judge the EUT performance, a CCD camera is used to monitor its screen. All the scanning conditions are as following:

Condition of Test	Remark
1. Fielded Strength	3V/m (Severity Level 2)
2. Radiated Signal	Modulated
3. Scanning Frequency	80-1000MHz
4. Sweep time of radiated	1800MHz
5. Dwell Time	2600MHz
	3500MHz
	5000MHz
	0.0015 Decade/s
	1 Sec.

RF Field Strength Susceptibility Test Results

EUT	: Gaming Mouse	Temperature	: 22°C
M/N	: AGM600	Humidity	: 50 %
Test Voltage	: DC 5V	Test Mode	: On
Field Strength	: 3 V/m	Test Date	: 2022-05-05
Test Engineer:	Bill	Frequency Range:	80 MHz,1000 MHz 1800 MHz,2600MHz 3500MHz,5000MHZ
Modulation:	<input type="checkbox"/> None	<input type="checkbox"/> Pulse	<input checked="" type="checkbox"/> AM 1KHz 80%
	Frequency Rang 1: 80~ 1000MHz	Frequency Rang 2:	1800 MHz~2600MHz 3500 MHz~5000MHZ
Steps	1 / %	# / %	
	Horizontal	Vertical	Horizontal Vertical
Front	PASS	PASS	PASS PASS
Right	PASS	PASS	PASS PASS
Rear	PASS	PASS	PASS PASS
Left	PASS	PASS	PASS PASS
Test Equipment : 1. Signal Generator : 2031 (MARCONI) 2. Power Amplifier : 500A100 & 100W/1000M1 (A&R) 3. Power Antenna : 3108 (EMCO) & AT1080 (A&R) 4. Field Monitor : FM2000 (A&R)			
Note: Note: (The Criterion) A:Normal performance within the specification limits; B:Temporary degradation or less of function or performance which is self-recoverable; C:Temporary degradation or loss of function or performance which requires operator intervention or system reset;			

9. ELECTRICAL FAST TRANSIENT/BURST IMMUNITY TEST

9.1 Block Diagram of Test Setup

9.1.1. Block Diagram of the EUT

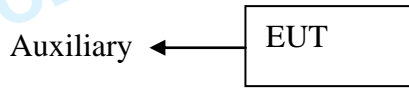

(EUT: Gaming Mouse)

9.1.2. EFT Test Setup

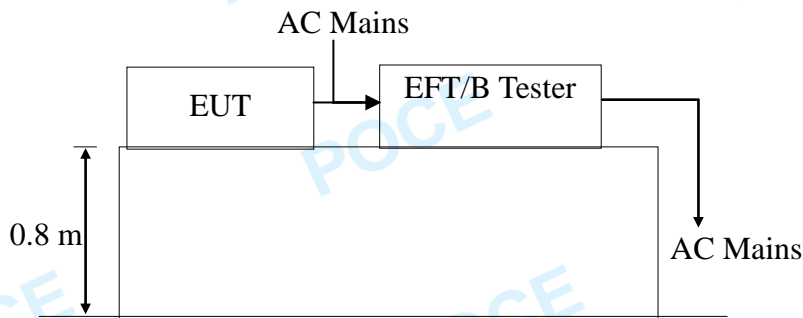

(EUT: Gaming Mouse)

9.2 Test Standard

EN 55035:2017/A11:2020 (EN61000-4-4:2012)
Severity Level 2 at 1KV

9.3 Severity Levels and Performance Criterion

9.3.1 Severity level

Open Circuit Output Test Voltage $\pm 10\%$		
Level	On AC Power Lines	On I/O (Input/Output) Signal data and control lines
1.	0.5 KV	0.25 KV
2.	1 KV	0.5 KV
3.	2 KV	1 KV
4.	4 KV	2 KV
X	Special	Special

9.3.2 Performance criterion: **B**

9.4 Test Procedure

The EUT is put on the table which is 0.8 meter high above the ground. This reference ground plane shall project beyond the EUT by at least 0.1m on all sides and the minimum distance between EUT and all other conductive structure, except the ground plane beneath the EUT, shall be more than 0.5m.

9.4.1 For input and output AC power ports:

The EUT is connected to the power mains by using a coupling device which couples the EFT interference signal to AC power lines. Both polarities of the test voltage should be applied during compliance test and the duration of the test is 2 mins.

9.4.2 For signal lines and control lines ports:

No I/O ports. It's unnecessary to test.

9.4.3 For DC output line ports:

It's unnecessary to test.

Note:. N/A denotes test is not applicable in this test report.

10. SURGE IMMUNITY TEST

10.1 Block Diagram of Test Setup

10.1.1 Block Diagram of the EUT

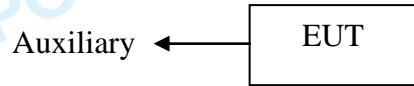

(EUT: Gaming Mouse)

10.1.2. Surge Test Setup

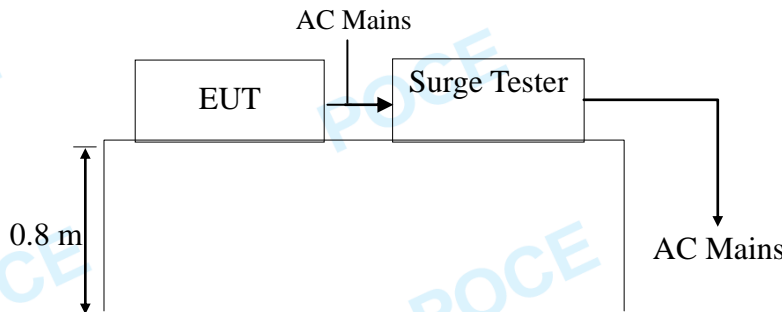

(EUT: Gaming Mouse)

10.2 Test Standard

EN 55035:2017/A11:2020 (EN61000-4-5: 2014+A1:2017)

Severity Level: Line to Line: Level 2, 1.0KV

10.3 Severity Levels and Performance Criterion

10.3.1. Severity level

Severity Level	Open-Circuit Test Voltage KV
1	0.5
2	1.0
3	2.0
4	4.0
*	Special

10.3.2 Performance criterion : **B**

10.4 Test Procedure

- 1) Set up the EUT and test generator as shown on Section 10.1.2.
- 2) For line to line coupling mode, provide a 1.0 KV 1.2/50us voltage surge (at open-circuit condition) and 8/20us current surge to EUT selected points.
- 3) At least 5 positive and 5 negative (polarity) tests with a maximum 1/min repetition rate are conducted during test.
- 4) Different phase angles are done individually.
- 5) Record the EUT operating situation during compliance test and decide the EUT immunity criterion for above each test.

Note:. N/A denotes test is not applicable in this test report.

11. INJECTED CURRENTS SUSCEPTIBILITY TEST

11.1 Block Diagram of Test Setup

11.1.1 Block Diagram of the EUT

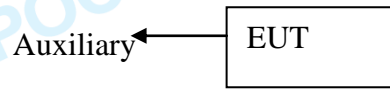

(EUT:Gaming Mouse)

11.1.2 Block Diagram of Test Setup

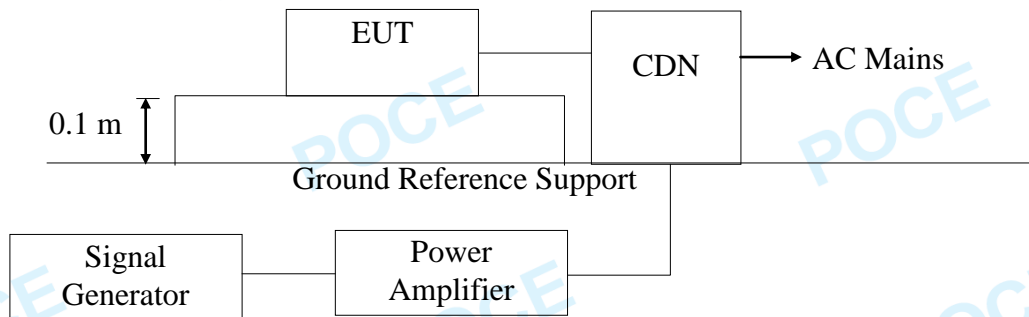

(EUT:Gaming Mouse)

11.2 Test Standard

EN 55035:2017/A11:2020 (EN61000-4-6: 2014+AC:2015)

Severity Level 2 at 3V (rms), 0.15MHz ~ 10MHz

Severity Level 2 and Level 1 at 3 V to 1V (rms), 10MHz ~ 30MHz

Severity Level 1 at 1V (rms), 30 MHz ~ 80MHz

11.3 Severity Levels and Performance Criterion

11.3.1 Severity level

Level	Field Strength V
1	1
2	3
3	10
X	Special

11.3.2 Performance criterion: A

11.4 Test Procedure

- 1) Set up the EUT, CDN and test generators as shown on Section 11.1.2.
- 2) Let the EUT work in test mode and measure it.
- 3) The EUT are placed on an insulating support 0.1m high above a ground reference plane. CDN (coupling and decoupling device) is placed on the ground plane about 0.3m from EUT. Cables between CDN and EUT are as short as possible, and their height above the ground reference plane shall be between 30 and 50 mm (where possible).
- 4) The disturbance signal described below is injected to EUT through CDN.
- 5) The EUT operates within its operational mode(s) under intended climatic conditions after power on.
- 6) The frequency range is swept from 150KHz to 80MHz using 3V signal level, and with the disturbance signal 80% amplitude modulated with a 1KHz sine wave.
- 7) The rate of sweep shall not exceed 1.5×10^{-3} decades/s. Where the frequency is swept incrementally, the step size shall not exceed 1% of the start and thereafter 1% of the preceding frequency value.
- 8) Recording the EUT operating situation during compliance testing and decide the EUT immunity criterion.

Note: N/A denotes test is not applicable in this test report.

12. MAGNETIC FIELD SUSCEPTIBILITY TEST

12.1 Block Diagram of Test

12.1.1 Block diagram of test setup

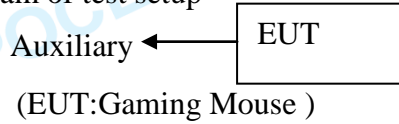

12.1.2 Magnetic field test setup

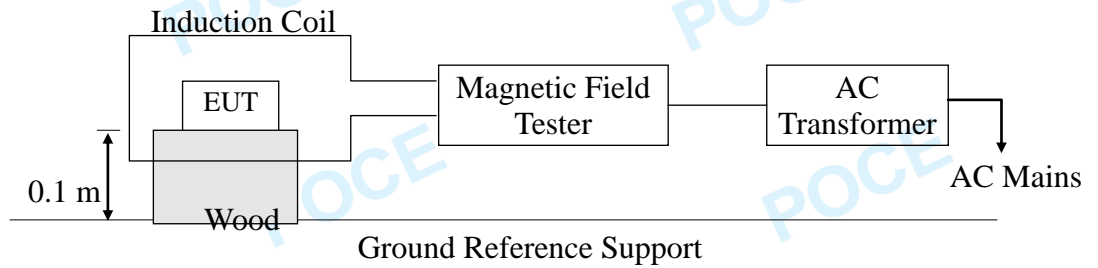

12.2 Test Standard

EN 55035:2017/A11:2020 (EN61000-4-8: 2010) (Severity Level: Level 1, 1A / m)

12.3 Severity Levels and Performance Criterion

12.3.1 Severity Levels

Level	Field Strength A/m
1	1
2	3
3	10
4	30
5	100
X	Special

12.3.2 Performance Criterion: A

12.4 Test Procedure

The EUT is placed in the middle of a induction coil (1*1m), under which is a 1*1*0.1m (high) table, this small table is also placed on a larger table,0.8 m above the ground. Both horizontal and vertical polarization of the induction coil are set on test, so that each side of the EUT is affected by the magnetic field. Also can reach the same aim by change the position of the EUT.

Magnetic Field Immunity Test Result

EUT	: Gaming Mouse	Temperature:	20°C
M/N	: AGM600	Humidity :	50%
Test Voltage	: DC 5V	Test Mode :	On
Test Engineer	: Bill	Test Date :	2022-05-05
Test Level (A/M)	Testing Duration	Coil Orientation	Result
1	5 mins	X	Pass
1	5 mins	Y	Pass
1	5 mins	Z	Pass
Test Level (A/M)	Testing Duration	Coil Orientation	Result
/	/	/	/
/	/	/	/
/	/	/	/
<p>Test Equipment :Magnetic Field Tester Model: HPFM T</p> <p>Note: (The Criterion) A:Normal performance within the specification limits; B:Temporary degradation or less of function or performance which is self-recoverable; C:Temporary degradation or loss of function or performance which requires operator intervention or system reset;</p>			

13. VOLTAGE DIPS AND INTERRUPTIONS TEST

13.1 Block Diagram of Test Setup

13.1.1 Block Diagram of the EUT

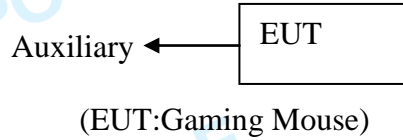

13.1.2 Dips Test Setup

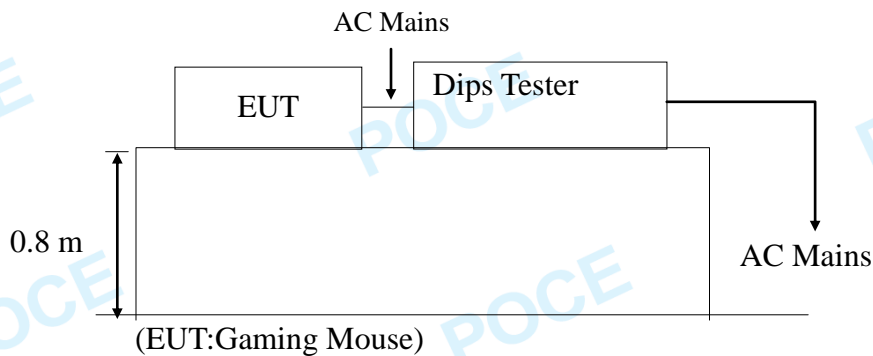

13.2 Test Standard

EN 55035:2017/A11:2020 (EN61000-4-11: 2004/AC:2017)

13.3 Severity Levels and Performance Criterion

13.3.1 Severity level

Test Level %UT	Voltage dip and short interruptions %UT	Duration (in period)
0	100	0.5 1
40	60	5 10
70	30	25 50 *

13.3.2 Performance criterion : **B&C&C**

13.4 Test Procedure

- 1) Set up the EUT and test generator as shown on Section 13.1.2.
- 2) The interruptions is introduced at selected phase angles with specified duration.
- 3) Record any degradation of performance.

Note:. N/A denotes test is not applicable in this test report.

14. PHOTOGRAPH

14.1 Photo of Radiated Emission

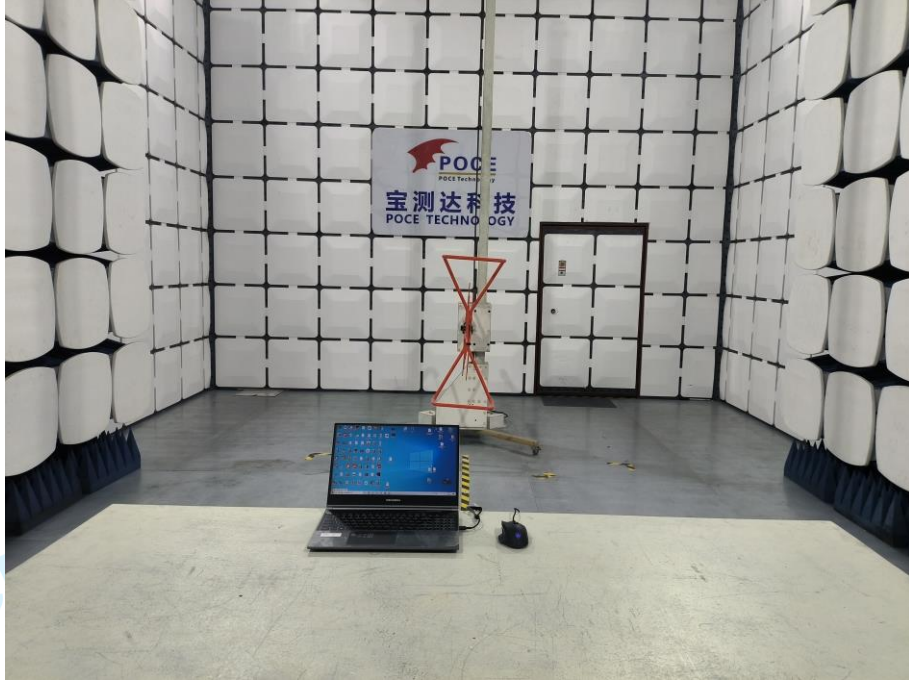

15. PHOTOGRAPHS OF EUT



Fig.1



Fig.2



Fig.3

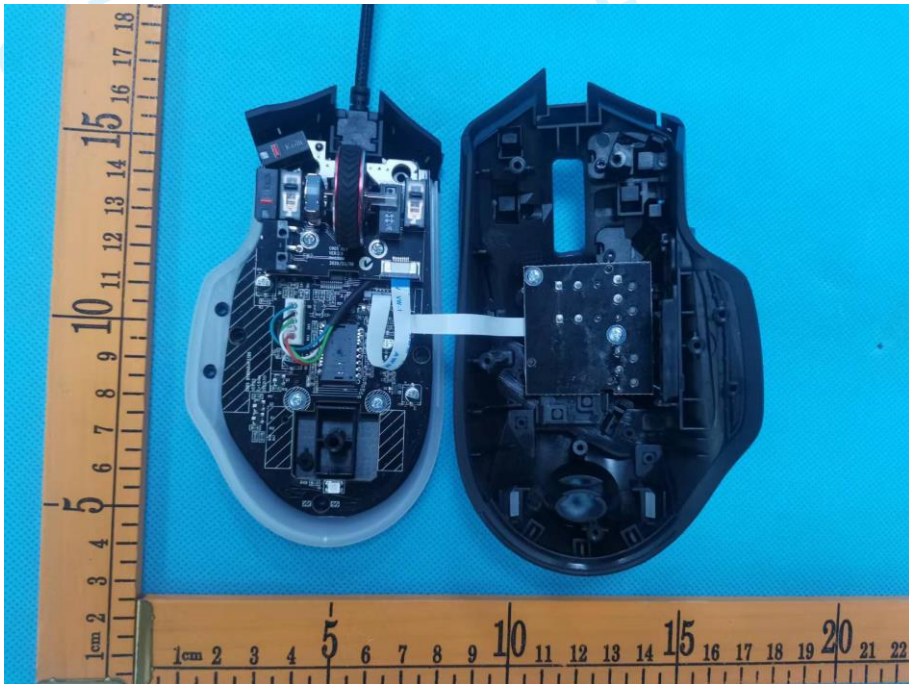

Fig.4

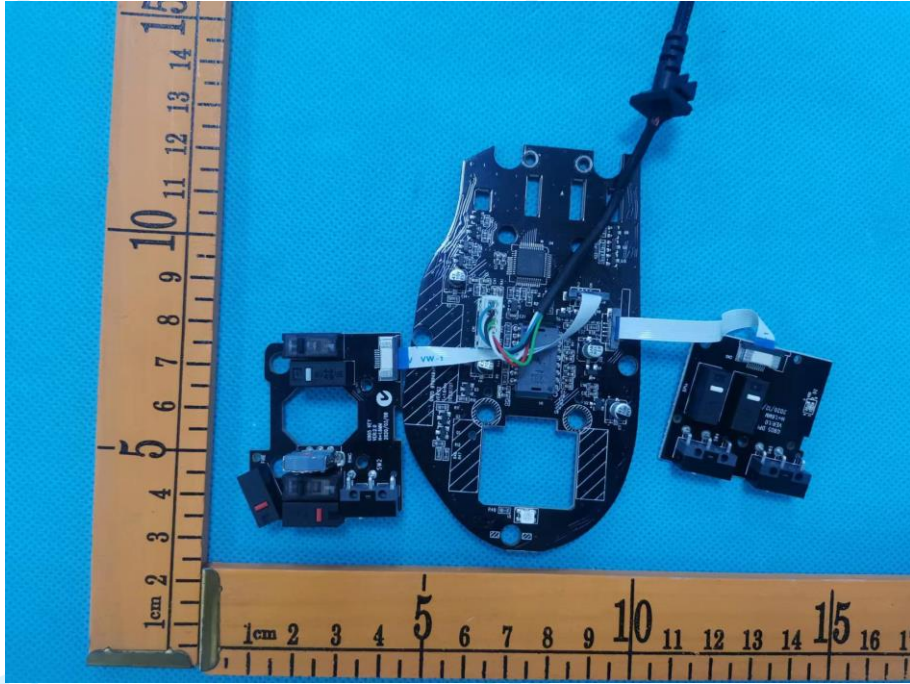

Fig.5

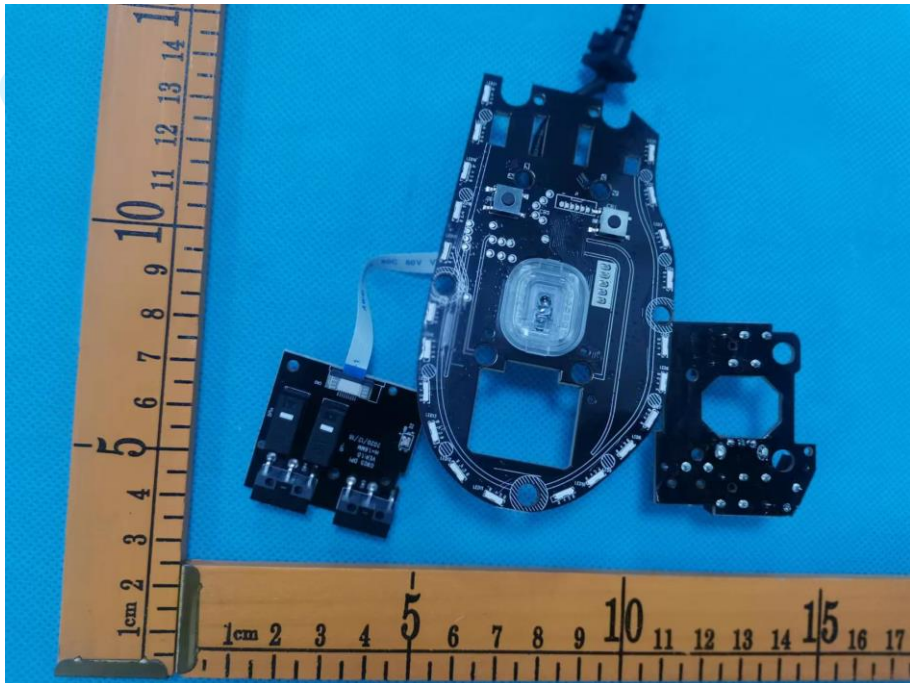

Fig.6

*****THE END OF REPORT*****