

FCC&ISED EMC Test Report

Project No. : 2001C073
Equipment : LCD Monitor
Brand Name : N/A
Test Model : **24P2*****(*=0-9,A-Z,a-z,+,-,/,\ or blank)
Series Model : N/A
Applicant : TPV Electronics (Fujian) Co., Ltd.
Address : Rongqiao Economic and Technological Development Zone, Fuqing City,
Fujian Province, P.R. China
Date of Receipt : Jan. 14, 2020
Date of Test : Feb. 10, 2020 ~ Feb. 28, 2020
Issued Date : Mar. 30, 2020
Report Version : R00
Test Sample : Engineering Sample No.: DG20200115108
Standard(s) : FCC Part 15, Subpart B
ICES-003 Issue 6:2016
ICES-003 Issue 6:2016 (updated April 2019)

The above equipment has been tested and found compliance with the requirement of the relative standards by BTL Inc.



Prepared by : Kang Zhang

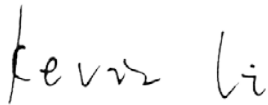

Approved by : Kevin Li



Certificate #5123.02

Add: No.3, Jinshagang 1st Road, Shixia, Dalang Town, Dongguan, Guangdong, China.

Tel: +86-769-8318-3000

Web: www.newbtl.com

Declaration

BTL represents to the client that testing is done in accordance with standard procedures as applicable and that test instruments used has been calibrated with standards traceable to international standard(s) and/or national standard(s).

BTL's reports apply only to the specific samples tested under conditions. It is manufacture's responsibility to ensure that additional production units of this model are manufactured with the identical electrical and mechanical components. **BTL** shall have no liability for any declarations, inferences or generalizations drawn by the client or others from **BTL** issued reports.

The report must not be used by the client to claim product certification, approval, or endorsement by NIST, A2LA, or any agency of the U.S. Government.

This report is the confidential property of the client. As a mutual protection to the clients, the public and ourselves, the test report shall not be reproduced, except in full, without our written approval.

BTL's laboratory quality assurance procedures are in compliance with the **ISO/IEC 17025** requirements, and accredited by the conformity assessment authorities listed in this test report.

BTL is not responsible for the sampling stage, so the results only apply to the sample as received.

The information, data and test plan are provided by manufacturer which may affect the validity of results, so it is manufacturer's responsibility to ensure that the apparatus meets the essential requirements of applied standards and in all the possible configurations as representative of its intended use.

Limitation

For the use of the authority's logo is limited unless the Test Standard(s)/Scope(s)/Item(s) mentioned in this test report is (are) included in the conformity assessment authorities acceptance respective.

Please note that the measurement uncertainty is provided for informational purpose only and are not use in determining the Pass/Fail results.

Table of Contents	Page
REPORT ISSUED HISTORY	4
1 . SUMMARY OF TEST RESULTS	5
1.1 TEST FACILITY	6
1.2 MEASUREMENT UNCERTAINTY	6
1.3 TEST ENVIRONMENT CONDITIONS	7
2 . GENERAL INFORMATION	8
2.1 GENERAL DESCRIPTION OF EUT	8
2.2 DESCRIPTION OF TEST MODES	9
2.3 EUT OPERATING CONDITIONS	10
2.4 BLOCK DIAGRAM SHOWING THE CONFIGURATION OF SYSTEM TESTED	10
2.5 DESCRIPTION OF SUPPORT UNITS	11
3 . EMC EMISSION TEST	12
3.1 AC POWER LINE CONDUCTED EMISSIONS TEST	12
3.1.1 LIMIT	12
3.1.2 MEASUREMENT INSTRUMENTS LIST	12
3.1.3 TEST PROCEDURE	13
3.1.4 DEVIATION FROM TEST STANDARD	13
3.1.5 TEST SETUP	13
3.1.6 TEST RESULTS	13
3.2 RADIATED EMISSIONS 30 MHZ TO 1 GHZ	20
3.2.1 LIMIT	20
3.2.2 MEASUREMENT INSTRUMENTS LIST	20
3.2.3 TEST PROCEDURE	21
3.2.4 DEVIATION FROM TEST STANDARD	21
3.2.5 TEST SETUP	21
3.2.6 TEST RESULTS-BELOW 1 GHZ	21
3.3 RADIATED EMISSIONS ABOVE 1 GHZ	28
3.3.1 LIMIT	28
3.3.2 MEASUREMENT INSTRUMENTS LIST	28
3.3.3 TEST PROCEDURE	29
3.3.4 DEVIATION FROM TEST STANDARD	29
3.3.5 TEST SETUP	29
3.3.6 TEST RESULTS-ABOVE 1 GHZ	30
4 . EUT TEST PHOTO	37

REPORT ISSUED HISTORY

Report Version	Description	Issued Date
R00	Original Issue.	Mar. 30, 2020

1. SUMMARY OF TEST RESULTS

Emission		
Ref Standard(s)	Test Item	Result
ANSI C63.4-2014	AC Power Line Conducted Emissions	PASS
	Radiated Emissions 30 MHz to 1 GHz	PASS
	Radiated Emissions Above 1 GHz	PASS

1.1 TEST FACILITY

The test facilities used to collect the test data in this report at the location of No.3, Jinshagang 1st Road, Shixia, Dalang Town, Dongguan, Guangdong, China.

BTL's Test Firm Registration Number for FCC: 357015

BTL's Designation Number for FCC: CN1240

BTL's Test Firm Registration Number for ISED: 4428B

1.2 MEASUREMENT UNCERTAINTY

ISO/IEC 17025 requires that an estimate of the measurement uncertainties associated with the emissions test results be included in the report. The measurement uncertainties given below are based on a 95% confidence level (based on a coverage factor (k=2))

The BTL measurement uncertainty as below table:

A. AC power line conducted emissions test:

Test Site	Method	Measurement Frequency Range	U,(dB)
DG-C01	CISPR	150kHz ~ 30MHz	2.90

B. Radiated emissions test:

Test Site	Method	Measurement Frequency Range	Ant. H / V	U,(dB)
DG-CB08 (3m)	CISPR	30MHz ~ 200MHz	V	3.72
		30MHz ~ 200MHz	H	3.02
		200MHz ~ 1,000MHz	V	4.20
		200MHz ~ 1,000MHz	H	3.66

Test Site	Method	Measurement Frequency Range	U,(dB)
DG-CB08 (3m)	CISPR	1GHz ~ 6GHz	4.36

Note: Unless specifically mentioned, the uncertainty of measurement has not been taken into account to declare the compliance or non-compliance to the specification.

1.3 TEST ENVIRONMENT CONDITIONS

Test Item	Temperature	Humidity	Tested By
AC Power Line Conducted Emissions	25°C	53%	Gatsby Wang
Radiated emissions 30 MHz to 1 GHz	25°C	60%	Promise Yin
Radiated emissions above 1 GHz	25°C	60%	Scott Xiang

2. GENERAL INFORMATION

2.1 GENERAL DESCRIPTION OF EUT

Equipment	LCD Monitor
Brand Name	N/A
Test Model	**24P2*****(*=0-9,A-Z,a-z,+,-,/,\ or blank)
Series Model	N/A
Model Difference(s)	Only differ in model name due to marketing purpose.
Power Source	AC Mains.
Power Rating	100-240V~ 50-60Hz 1.5A
Connecting I/O Port(s)	1* AC port 1* D-SUB port 5* USB port 1* DP port 1* HDMI port 1* Earphone port
Classification Of EUT	Class B
Highest Internal Frequency(Fx)	148.5MHz

Cable Type	Shielded Type	Ferrite Core	Length(m)	Note
AC Power Cord	Non-shielded	NO	1.8/1.5/1.2	1.8m is worst case Detachable
D-SUB	Shielded	YES	1.8/1.5/1.2	Bonded two Ferrite Cores
Display	Shielded	NO	1.8/1.5/1.2	-
HDMI	Shielded	NO	1.8/1.5/1.2	-

Note:

1. For a more detailed features description, please refer to the manufacturer's specifications or the user's manual.
2. Power cable 1.8m, 1.5m, 1.2m length, worst case is Power cable 1.8m with D-SUB+ Display + HDMI length testing and recording in test report.

2.2 DESCRIPTION OF TEST MODES

To investigate the maximum EMI emission characteristics generated from EUT, the test system was pre-scanning tested based on the consideration of following EUT operation mode or test configuration mode which possibly have effect on EMI emission level. Each of these EUT operation mode(s) or test configuration mode(s) mentioned above was evaluated respectively.

Pretest Mode	Description
Mode 1	HDMI 1920*1080/75Hz 1.8m H
Mode 2	Display 1920*1080/75Hz 1.8m H
Mode 3	D-SUB 1920*1080/60Hz 1.8m H
Mode 4	HDMI 1080P 1.8m H
Mode 5	HDMI 1280*1024/60Hz 1.8m H
Mode 6	HDMI 640*480/60Hz 1.8m H
Mode 7	HDMI 1920*1080/75Hz 1.5m H
Mode 8	HDMI 1920*1080/75Hz 1.2m H
Mode 9	HDMI 1920*1080/75Hz 1.8m V

AC Power Line Conducted Emissions test	
Final Test Mode	Description
Mode 1	HDMI 1920*1080/75Hz 1.8m H
Mode 2	Display 1920*1080/75Hz 1.8m H
Mode 4	HDMI 1080P 1.8m H

Radiated emissions 30 MHz to 1 GHz test	
Final Test Mode	Description
Mode 1	HDMI 1920*1080/75Hz 1.8m H
Mode 2	Display 1920*1080/75Hz 1.8m H
Mode 4	HDMI 1080P 1.8m H

Radiated emissions Above 1 GHz test	
Final Test Mode	Description
Mode 1	HDMI 1920*1080/75Hz 1.8m H
Mode 2	Display 1920*1080/75Hz 1.8m H
Mode 4	HDMI 1080P 1.8m H

Evaluation description:

1. The maximum resolution is evaluated Mode 1-4. The worst case is Mode 1 and evaluated the middle and low resolution Mode 5 and Mode 6.
2. According to the client's requirement, choose Mode 1, Mode 2, Mode 4 and recorded in test report.

2.3 EUT OPERATING CONDITIONS

The EUT exercise program used during radiated and/or conducted emission measurement was designed to exercise the various system components in a manner similar to a typical use. The standard test signals and output signal as following:

1. EUT connected to PC via HDMI & DP & D-SUB & USB cable.
2. EUT connected to Earphone via Earphone cable.
3. EUT connected to USB3.0 Hard Disk (B&C&D&E) via USB cable.
4. Printer connected to PC via Parallel cable.
5. Modem connected to PC via RS232 cable.

2.4 BLOCK DIAGRAM SHOWING THE CONFIGURATION OF SYSTEM TESTED

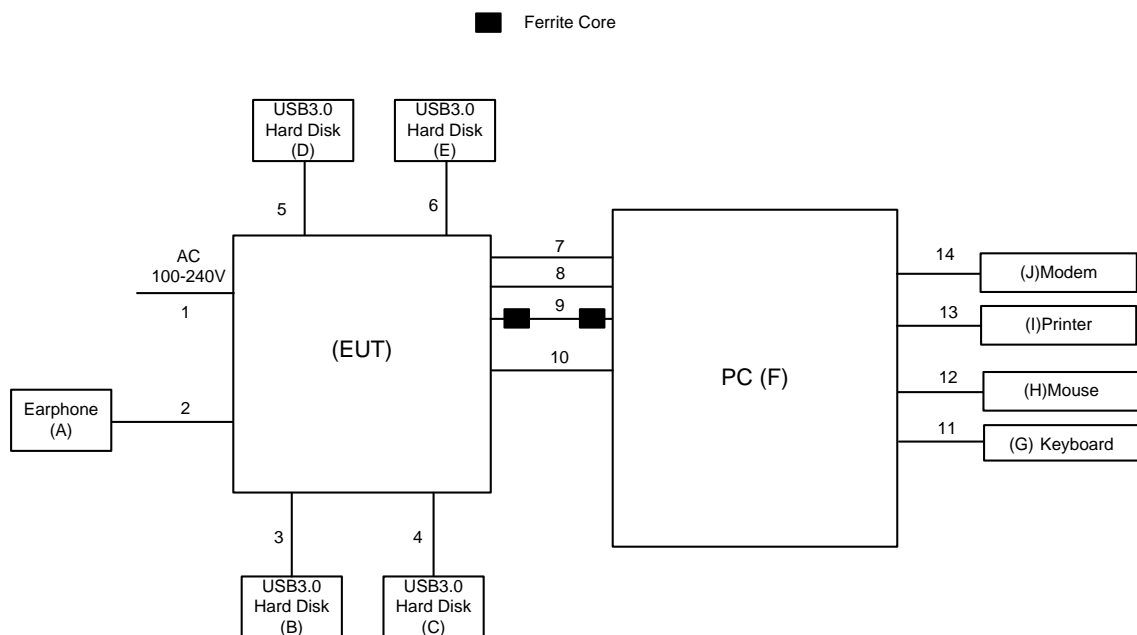

2.5 DESCRIPTION OF SUPPORT UNITS

The EUT has been tested as an independent unit together with other necessary accessories or support units. The following support units or accessories were used to form a representative test configuration during the tests.

Item	Equipment	Mfr/Brand	Model/Type No.	Series No.
A	Earphone	APPLE	N/A	N/A
B	USB3.0 Hard Disk	LACIE	Lacie S.A Series	NL34BFER
C	USB3.0 Hard Disk	LACIE	Lacie S.A Series	NL34BJSM
D	USB3.0 Hard Disk	LACIE	Lacie S.A Series	NL33PVLS
E	USB3.0 Hard Disk	LACIE	Lacie S.A Series	NL34BJRF
F	PC	DELL	Vostro 470	24454162837
G	Keyboard	DELL	KB212-B	CN0HTXH97158125004DXA01
H	Mouse	DELL	MS111-P	CN011D3V71581279OLOT
I	Printer	SII	DPU-414	3018507 B
j	Modem	ACEEX	DM-1414V	603002131

Item	Cable Type	Shielded Type	Ferrite Core	Length
1	AC Cable	NO	NO	1.8/1.5/1.2m
2	Earphone Cable	NO	NO	1.2m
3	USB Cable	YES	NO	1.0m
4	USB Cable	YES	NO	1.0m
5	USB Cable	YES	NO	1.0m
6	USB Cable	YES	NO	1.0m
7	HDMI Cable	YES	NO	1.8/1.5/1.2m
8	Display Cable	YES	NO	1.8/1.5/1.2m
9	D-SUB Cable	YES	YES	1.8/1.5/1.2m
10	USB Cable	YES	NO	1.8/1.5/1.2m
11	USB Cable	YES	NO	1.8m
12	USB Cable	YES	NO	1.8m
13	Parallel Cable	YES	NO	1.8m
14	RS232 Cable	YES	NO	1.8m

3. EMC EMISSION TEST

3.1 AC POWER LINE CONDUCTED EMISSIONS TEST

3.1.1 LIMIT

Frequency of Emission (MHz)	Class B (dBuV)	
	Quasi-peak	Average
0.15 - 0.5	66 - 56 *	56 - 46 *
0.5 - 5.0	56.00	46.00
5.0 - 30.0	60.00	50.00

Note:

- (1) The tighter limit applies at the band edges.
- (2) The limit of " * " marked band means the limitation decreases linearly with the logarithm of the frequency in the range.
- (3) The test result calculated as following:
 Measurement Value = Reading Level + Correct Factor
 Correct Factor = Insertion Loss + Cable Loss + Attenuator Factor(if use)
 Margin Level = Measurement Value - Limit Value

3.1.2 MEASUREMENT INSTRUMENTS LIST

Item	Kind of Equipment	Manufacturer	Type No.	Serial No.	Calibrated until
1	Measurement Software	Farad	EZ-EMC Ver.NB-03A1-01	N/A	N/A
2	50Ω Terminator	SHX	TF2-3G-A	08122901	Mar. 10, 2020
3	TWO-LINE V-NETWORK	R&S	ENV216	100526	Mar. 10, 2020
4	EMI Test Receiver	R&S	ESR3	101862	Aug. 03, 2020
5	Artificial-Mains Network	SCHWARZBECK	NSLK 8127	8127685	Mar. 10, 2020
6	TRANSIENT LIMITER	EM	EM-7600	772	Mar. 10, 2020
7	Cable	N/A	N/A(6m)	N/A	Mar. 12, 2020

Remark: "N/A" denotes no model name, serial no. or calibration specified.

All calibration period of equipment list is one year.

3.1.3 TEST PROCEDURE

- a. The EUT was placed 0.8 meters from the horizontal ground plane with EUT being connected to the power mains through a line impedance stabilization network (LISN). All other support equipment powered from additional LISN(s). The LISN provide 50 Ohm/ 50uH of coupling impedance for the measuring instrument.
- b. Interconnecting cables that hang closer than 40 cm to the ground plane shall be folded back and forth in the center forming a bundle 30 to 40 cm long.
- c. I/O cables that are not connected to a peripheral shall be bundled in the center. The end of the cable may be terminated, if required, using the correct terminating impedance. The overall length shall not exceed 1 m.
- d. LISN at least 80 cm from nearest part of EUT chassis.
- e. For the actual test configuration, please refer to the related Item –EUT Test Photos.
- f. Measuring frequency range from 150KHz to 30MHz.

3.1.4 DEVIATION FROM TEST STANDARD

No deviation

3.1.5 TEST SETUP

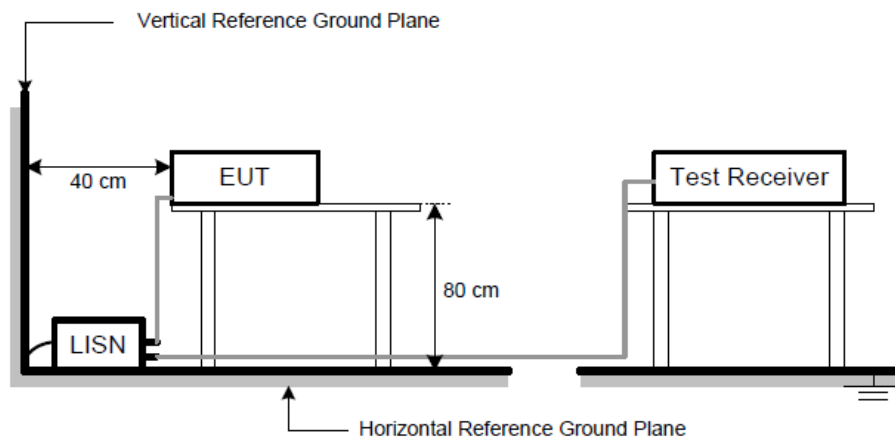

3.1.6 TEST RESULTS

Remark

- (1) Reading in which marked as QP means measurements by using are Quasi-Peak Mode with Detector BW=9 kHz; SPA setting in RBW=10 kHz, VBW =10 kHz, Swp. Time = 0.3 sec./MHz. Reading in which marked as AV means measurements by using are Average Mode with instrument setting in RBW=10 kHz, VBW=10 kHz, Swp. Time =0.3 sec./MHz.
- (2) All readings are QP Mode value unless otherwise stated AVG in column of 『Note』 . If the QP Mode Measured value compliance with the QP Limits and lower than AVG Limits, the EUT shall be deemed to meet both QP & AVG Limits and then only QP Mode was measured, but AVG Mode didn't perform. In this case, a “ * ” marked in AVG Mode column of Interference Voltage Measured.

Test Voltage	AC 120V/60Hz	Phase	Line
Test Mode	HDMI 1920*1080/75Hz 1.8m H		

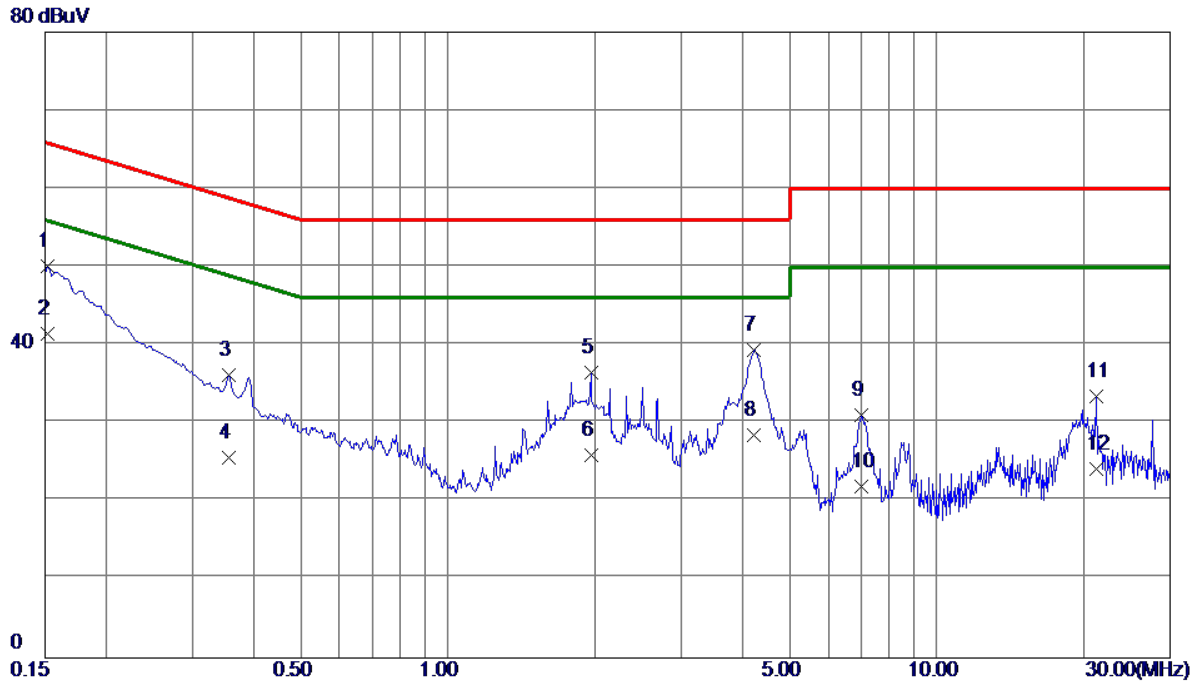

No.	Freq. MHz	Reading Level dBuV	Correct Factor dB	Measure ment dBuV	Limit dBuV	Margin dB	Detector
1	0.1522	40.50	9.58	50.08	65.88	-15.80	QP
2 *	0.1522	31.86	9.58	41.44	55.88	-14.44	AVG
3	0.3570	26.64	9.57	36.21	58.80	-22.59	QP
4	0.3570	15.98	9.57	25.55	48.80	-23.25	AVG
5	1.9635	26.78	9.71	36.49	56.00	-19.51	QP
6	1.9635	16.24	9.71	25.95	46.00	-20.05	AVG
7	4.2180	29.57	9.86	39.43	56.00	-16.57	QP
8	4.2180	18.55	9.86	28.41	46.00	-17.59	AVG
9	7.0283	20.99	10.04	31.03	60.00	-28.97	QP
10	7.0283	11.88	10.04	21.92	50.00	-28.08	AVG
11	21.1965	22.56	10.86	33.42	60.00	-26.58	QP
12	21.1965	13.27	10.86	24.13	50.00	-25.87	AVG

Test Voltage	AC 120V/60Hz	Phase	Neutral
Test Mode	HDMI 1920*1080/75Hz 1.8m H		

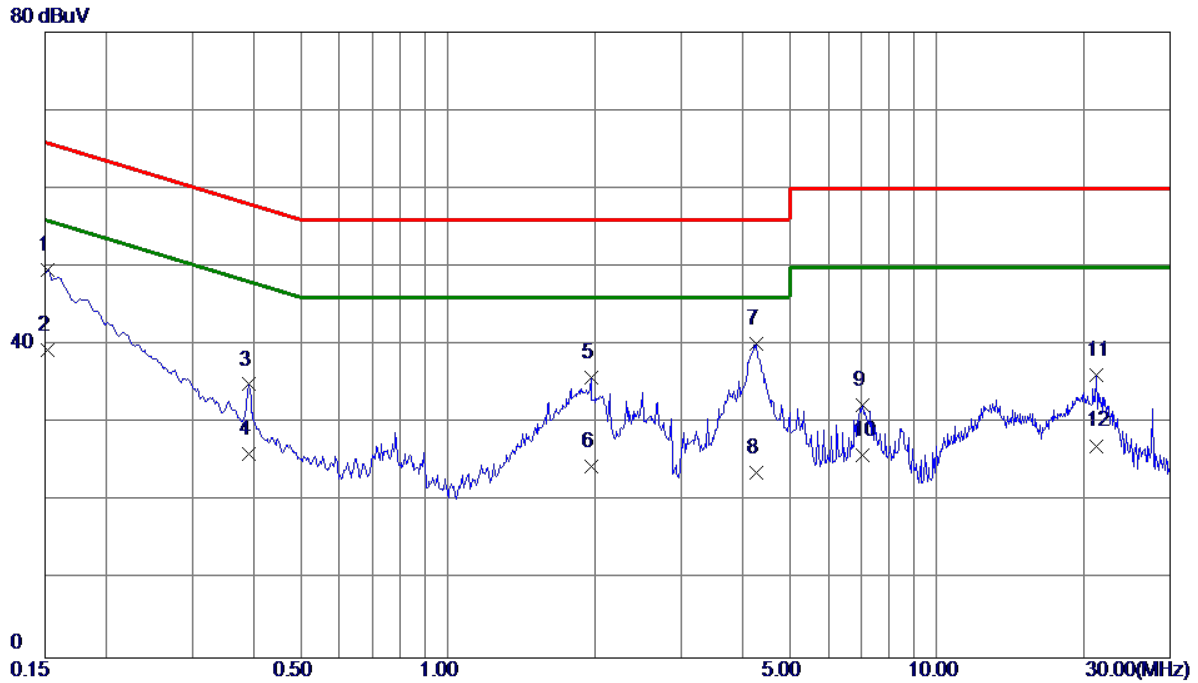

No.	Freq. MHz	Reading Level dBuV	Correct Factor dB	Measure ment dBuV	Limit dBuV	Margin dB	Detector
1	0.1522	40.07	9.55	49.62	65.88	-16.26	QP
2	0.1522	29.86	9.55	39.41	55.88	-16.47	AVG
3	0.3907	25.40	9.56	34.96	58.05	-23.09	QP
4	0.3907	16.52	9.56	26.08	48.05	-21.97	AVG
5	1.9635	26.20	9.70	35.90	56.00	-20.10	QP
6	1.9635	14.85	9.70	24.55	46.00	-21.45	AVG
7 *	4.2855	30.26	9.86	40.12	56.00	-15.88	QP
8	4.2855	13.85	9.86	23.71	46.00	-22.29	AVG
9	7.0440	22.21	10.04	32.25	60.00	-27.75	QP
10	7.0440	15.85	10.04	25.89	50.00	-24.11	AVG
11	21.1987	25.24	10.92	36.16	60.00	-23.84	QP
12	21.1987	16.20	10.92	27.12	50.00	-22.88	AVG

Test Voltage	AC 120V/60Hz	Phase	Line
Test Mode	Display 1920*1080/75Hz 1.8m H		

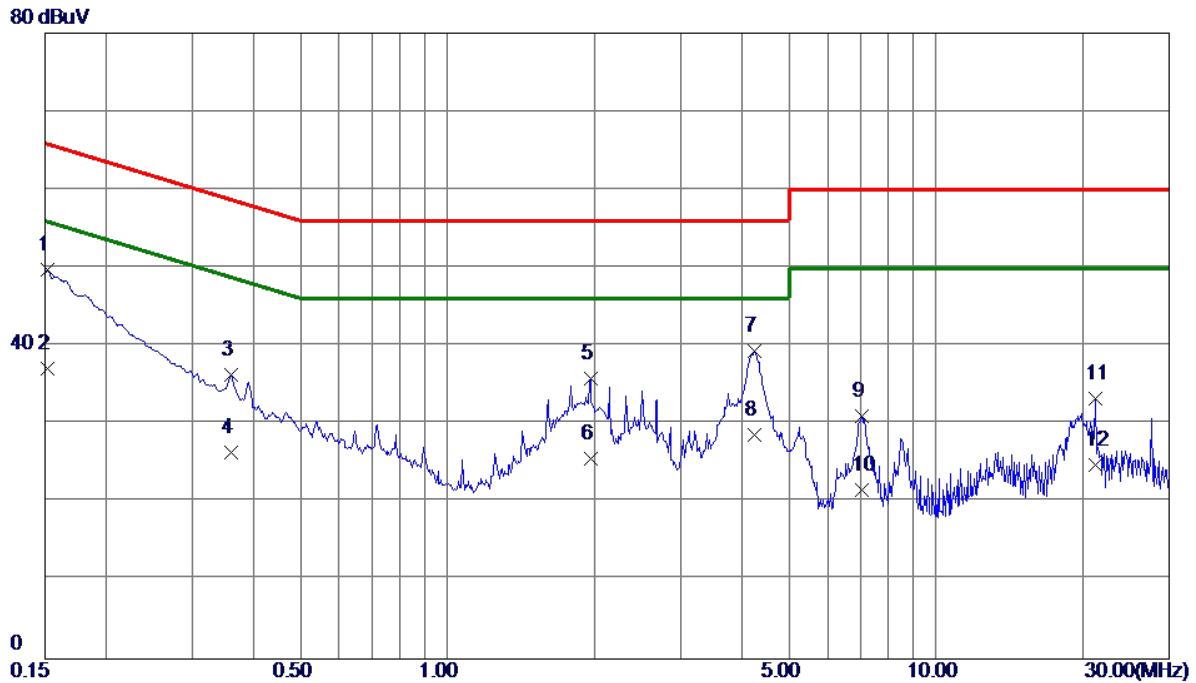

No.	Freq. MHz	Reading Level dBuV	Correct Factor dB	Measure ment dBuV	Limit dBuV	Margin dB	Detector
1 *	0.1522	40.13	9.58	49.71	65.88	-16.17	QP
2	0.1522	27.49	9.58	37.07	55.88	-18.81	AVG
3	0.3615	26.68	9.57	36.25	58.69	-22.44	QP
4	0.3615	16.86	9.57	26.43	48.69	-22.26	AVG
5	1.9635	26.20	9.71	35.91	56.00	-20.09	QP
6	1.9635	15.85	9.71	25.56	46.00	-20.44	AVG
7	4.2495	29.50	9.86	39.36	56.00	-16.64	QP
8	4.2495	18.74	9.86	28.60	46.00	-17.40	AVG
9	7.0463	21.02	10.04	31.06	60.00	-28.94	QP
10	7.0463	11.53	10.04	21.57	50.00	-28.43	AVG
11	21.1965	22.37	10.86	33.23	60.00	-26.77	QP
12	21.1965	13.95	10.86	24.81	50.00	-25.19	AVG

Test Voltage	AC 120V/60Hz	Phase	Neutral
Test Mode	Display 1920*1080/75Hz 1.8m H		

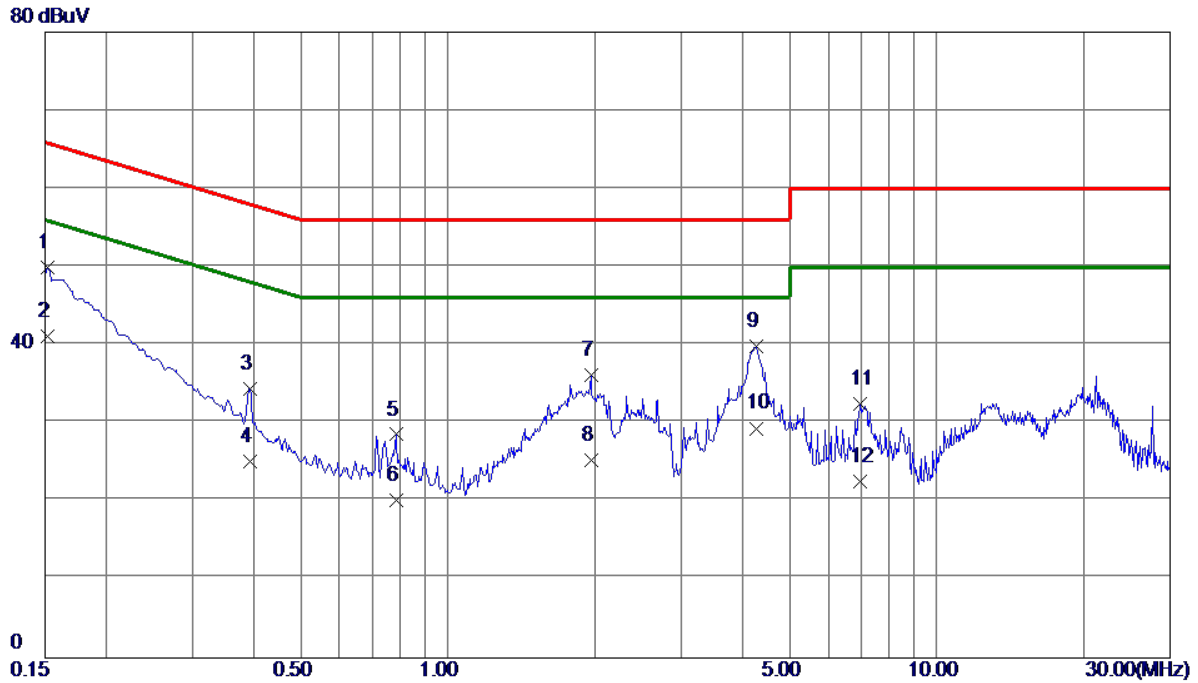

No.	Freq. MHz	Reading Level dBuV	Correct Factor dB	Measure ment dBuV	Limit dBuV	Margin dB	Detector
1	0.1522	40.39	9.55	49.94	65.88	-15.94	QP
2 *	0.1522	31.56	9.55	41.11	55.88	-14.77	AVG
3	0.3930	24.89	9.56	34.45	58.00	-23.55	QP
4	0.3930	15.55	9.56	25.11	48.00	-22.89	AVG
5	0.7822	18.95	9.61	28.56	56.00	-27.44	QP
6	0.7822	10.58	9.61	20.19	46.00	-25.81	AVG
7	1.9635	26.47	9.70	36.17	56.00	-19.83	QP
8	1.9635	15.52	9.70	25.22	46.00	-20.78	AVG
9	4.2675	29.93	9.86	39.79	56.00	-16.21	QP
10	4.2675	19.50	9.86	29.36	46.00	-16.64	AVG
11	6.9608	22.46	10.04	32.50	60.00	-27.50	QP
12	6.9608	12.56	10.04	22.60	50.00	-27.40	AVG

Test Voltage	AC 120V/60Hz	Phase	Line
Test Mode	HDMI 1080P 1.8m H		

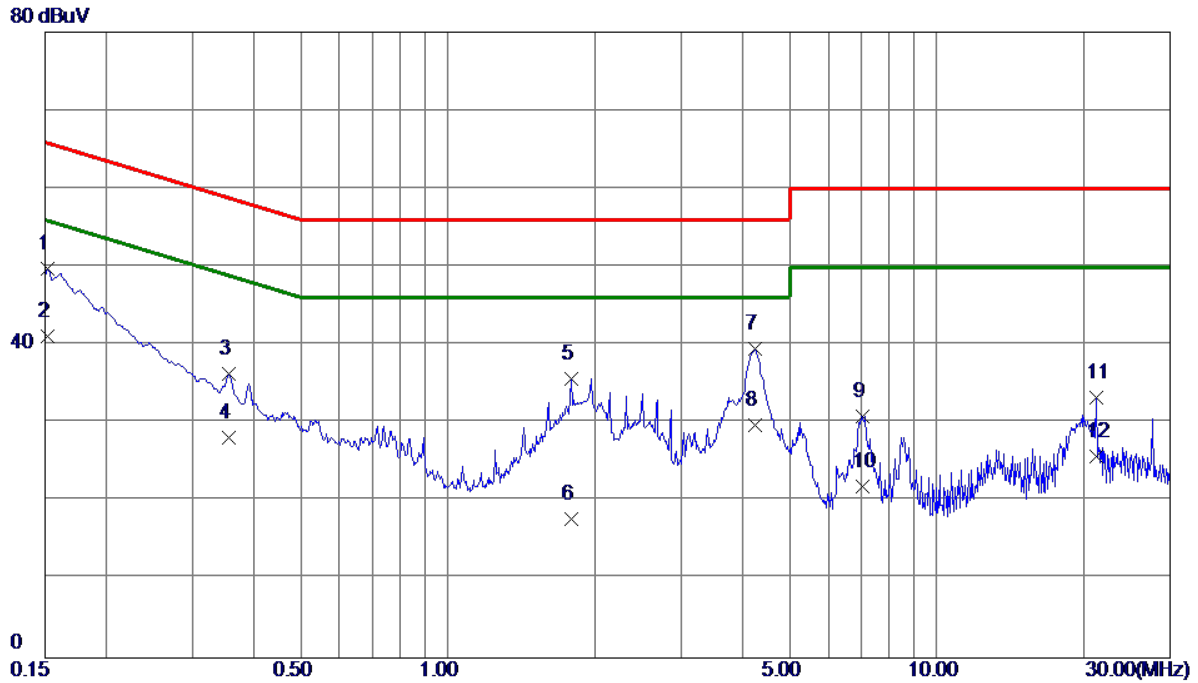

No.	Freq. MHz	Reading Level dBuV	Correct Factor dB	Measure ment dBuV	Limit dBuV	Margin dB	Detector
1	0.1522	40.15	9.58	49.73	65.88	-16.15	QP
2 *	0.1522	31.53	9.58	41.11	55.88	-14.77	AVG
3	0.3570	26.80	9.57	36.37	58.80	-22.43	QP
4	0.3570	18.53	9.57	28.10	48.80	-20.70	AVG
5	1.7835	26.01	9.70	35.71	56.00	-20.29	QP
6	1.7835	8.00	9.70	17.70	46.00	-28.30	AVG
7	4.2518	29.58	9.87	39.45	56.00	-16.55	QP
8	4.2518	19.85	9.87	29.72	46.00	-16.28	AVG
9	7.0508	20.87	10.04	30.91	60.00	-29.09	QP
10	7.0508	11.88	10.04	21.92	50.00	-28.08	AVG
11	21.1965	22.39	10.86	33.25	60.00	-26.75	QP
12	21.1965	14.94	10.86	25.80	50.00	-24.20	AVG

Test Voltage	AC 120V/60Hz	Phase	Neutral
Test Mode	HDMI 1080P 1.8m H		

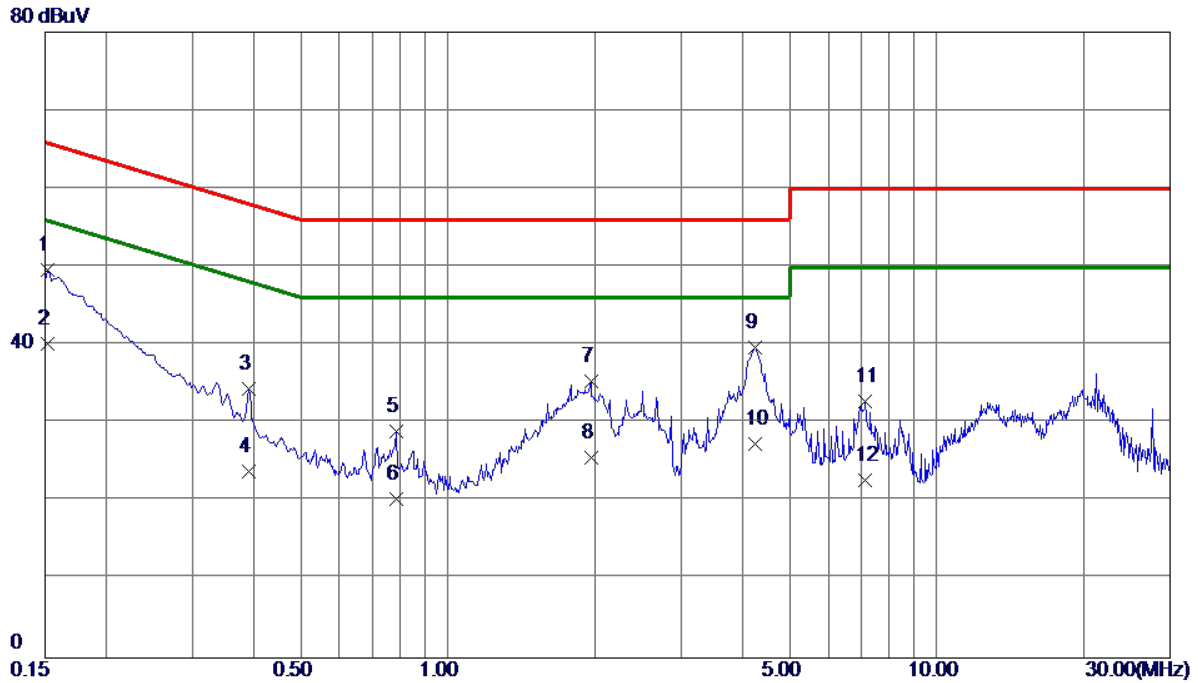

No.	Freq. MHz	Reading Level dBuV	Correct Factor dB	Measure ment dBuV	Limit dBuV	Margin dB	Detector
1	0.1522	40.02	9.55	49.57	65.88	-16.31	QP
2 *	0.1522	30.56	9.55	40.11	55.88	-15.77	AVG
3	0.3907	24.77	9.56	34.33	58.05	-23.72	QP
4	0.3907	14.26	9.56	23.82	48.05	-24.23	AVG
5	0.7822	19.35	9.61	28.96	56.00	-27.04	QP
6	0.7822	10.69	9.61	20.30	46.00	-25.70	AVG
7	1.9658	25.67	9.70	35.37	56.00	-20.63	QP
8	1.9658	15.95	9.70	25.65	46.00	-20.35	AVG
9	4.2495	29.91	9.85	39.76	56.00	-16.24	QP
10	4.2495	17.52	9.85	27.37	46.00	-18.63	AVG
11	7.1385	22.79	10.05	32.84	60.00	-27.16	QP
12	7.1385	12.65	10.05	22.70	50.00	-27.30	AVG

3.2 RADIATED EMISSIONS 30 MHZ TO 1 GHZ

3.2.1 LIMIT

30 MHz to 1 GHz

Frequency (MHz)	Class B (at 3m)	
	(uV/m) Field strength	(dBuV/m) Field strength
30 - 88	100	40
88 - 216	150	43.5
216 - 960	200	46
Above 960	500	54

NOTE:

- (1) The tighter limit applies at the band edges.
- (2) Emission level (dBuV/m) = $20\log$ Emission level (uV/m).
3m Emission level = 10m Emission level + $20\log(10m/3m)$.
- (3) The test result calculated as following:
Measurement Value = Reading Level + Correct Factor
Correct Factor = Antenna Factor + Cable Loss - Amplifier Gain(if use)
Margin Level = Measurement Value - Limit Value

3.2.2 MEASUREMENT INSTRUMENTS LIST

Item	Kind of Equipment	Manufacturer	Type No.	Serial No.	Calibrated until
1	Receiver	Keysight	N9038A	MY54450004	Aug. 03, 2020
2	Pre-Amplifier	EMC INSTRUMENT	EMC 9135	980284	Mar. 10, 2020
3	Trilog-Broadband Antenna	Schwarzbeck	VULB9168	946	Oct. 26, 2020
4	Cable	emci	LMR-400(5m+11m+15m)	N/A	Nov. 22, 2020
5	Measurement Software	Farad	EZ-EMC Ver.BTL-2ANT-1	N/A	N/A
6	Multi-Device Controller	ETS-Lindgren	2090	N/A	N/A
7	Attenuator	EMCI	EMCI-N-6-06	N0670	Dec. 02, 2020

Remark: "N/A" denotes no model name, no serial no. or no calibration specified.

All calibration period of equipment list is one year.

3.2.3 TEST PROCEDURE

- a. The measuring distance of 3 m shall be used for measurements. The EUT was placed on the top of a rotating table 0.8 meter above the ground at a 10 meter semi-anechoic chamber. The table was rotated 360 degrees to determine the position of the highest radiation.
- b. The height of the equipment or of the substitution antenna shall be 0.8 m, the height of the test antenna shall vary between 1 m to 4 m. Both horizontal and vertical polarizations of the antenna are set to make the measurement.
- c. For each suspected emission, the EUT was arranged to its worst case and then the antenna was tuned to heights find the maximum reading (used Bore sight function).
- d. The initial step in collecting radiated emission data is a receiver peak detector mode pre-scanning the measurement frequency range. Significant peaks are then marked and then Quasi Peak detector mode re-measured.
- e. All readings are Peak unless otherwise stated QP in column of Note. Peak denotes that the Peak reading compliance with the QP Limits and then QP Mode measurement didn't perform.
- f. For the actual test configuration, please refer to the related Item - Block Diagram of system tested.

3.2.4 DEVIATION FROM TEST STANDARD

No deviation

3.2.5 TEST SETUP

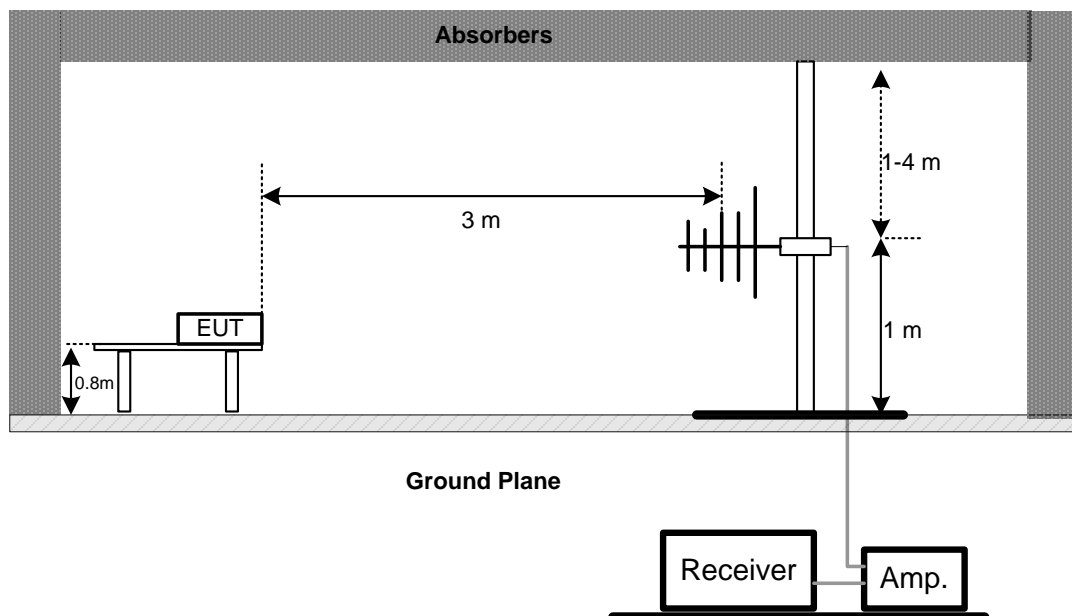

3.2.6 TEST RESULTS-BELOW 1 GHZ

Remark :

- (1) Measuring frequency range from 30 MHz to 1000 MHz
- (2) If the peak scan value lower limit more than 20 dB, then this signal data does not show in table.

Test Voltage	AC 120V/60Hz	Polarization	Vertical
Test Mode	HDMI 1920*1080/75Hz 1.8m H		

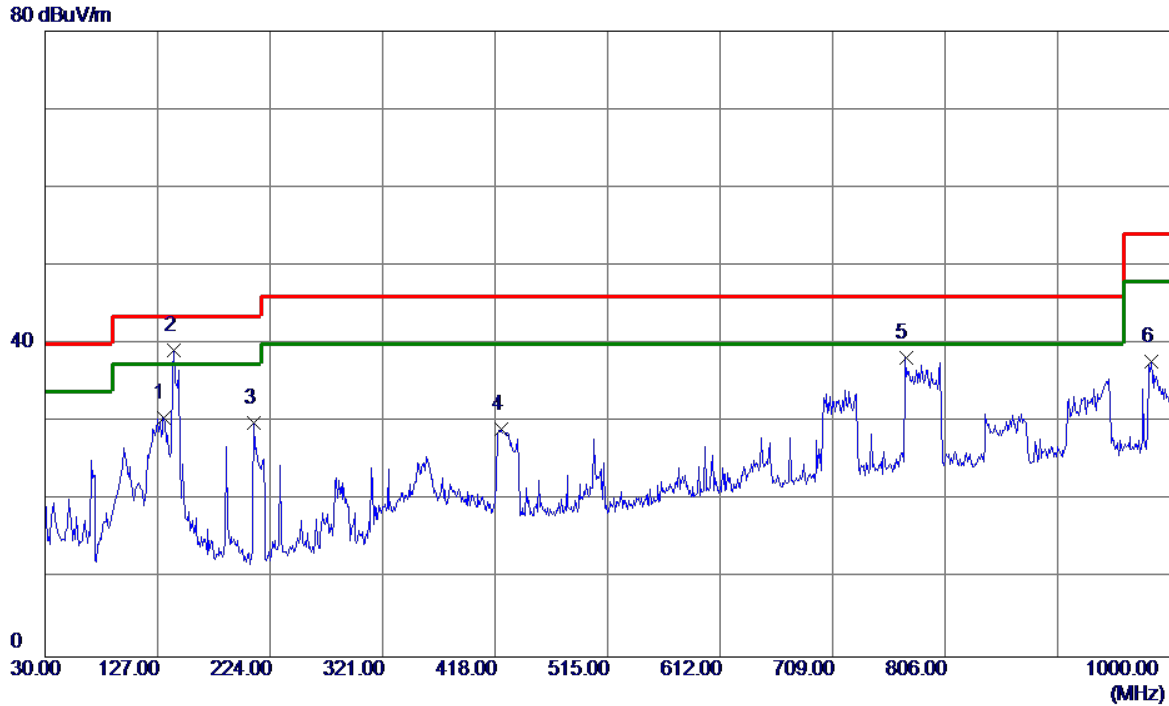

No.	Freq. MHz	Reading Level dBuV/m	Correct Factor dB	Measure ment dBuV/m	Limit dBuV/m	Margin dB	Detector
1	131.8500	47.84	-17.26	30.58	43.50	-12.92	QP
2 *	140.5800	55.55	-16.40	39.15	43.50	-4.35	QP
3	210.4200	48.61	-18.63	29.98	43.50	-13.52	QP
4	422.8500	40.80	-11.74	29.06	46.00	-16.94	QP
5	772.0500	43.36	-5.11	38.25	46.00	-7.75	QP
6	983.5100	39.88	-2.18	37.70	54.00	-16.30	QP

Test Voltage	AC 120V/60Hz	Polarization	Horizontal
Test Mode	HDMI 1920*1080/75Hz 1.8m H		

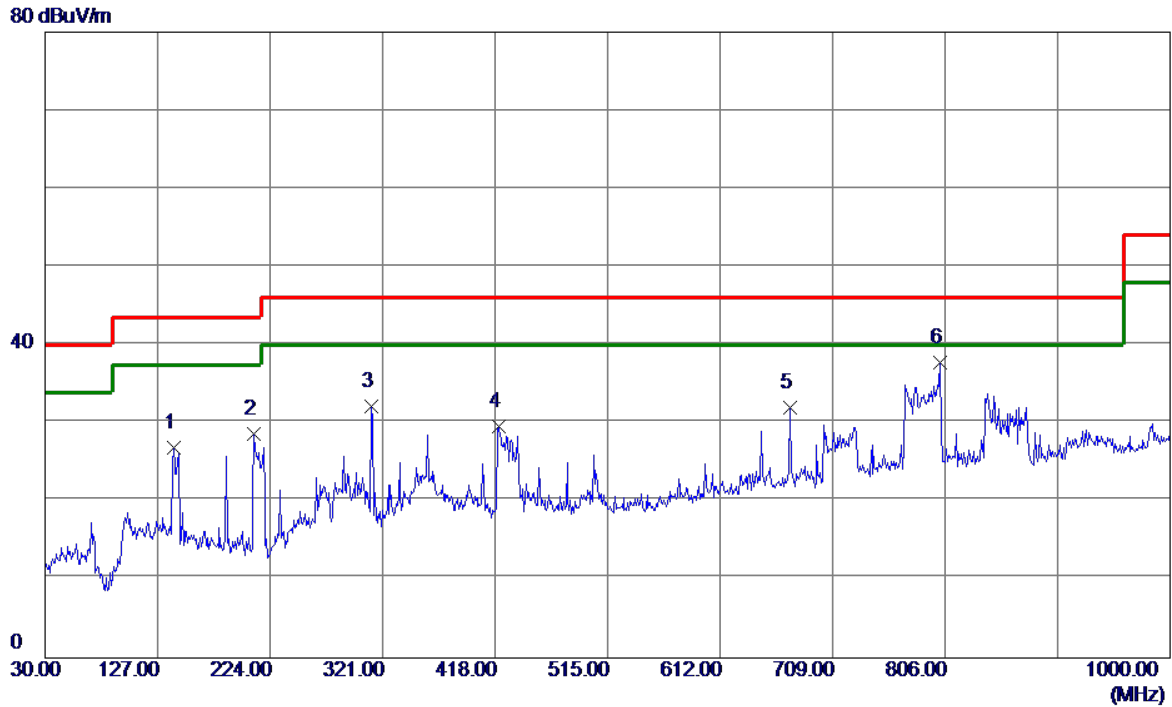

No.	Freq. MHz	Reading Level dBuV/m	Correct Factor dB	Measure ment dBuV/m	Limit dBuV/m	Margin dB	Detector
1	140.5800	43.30	-16.40	26.90	43.50	-16.60	QP
2	210.4200	47.30	-18.63	28.67	43.50	-14.83	QP
3	311.3000	46.47	-14.33	32.14	46.00	-13.86	QP
4	420.9100	41.42	-11.80	29.62	46.00	-16.38	QP
5	672.1400	38.91	-6.84	32.07	46.00	-13.93	QP
6 *	802.1200	42.48	-4.76	37.72	46.00	-8.28	QP

Test Voltage	AC 120V/60Hz	Polarization	Vertical
Test Mode	Display 1920*1080/75Hz 1.8m H		

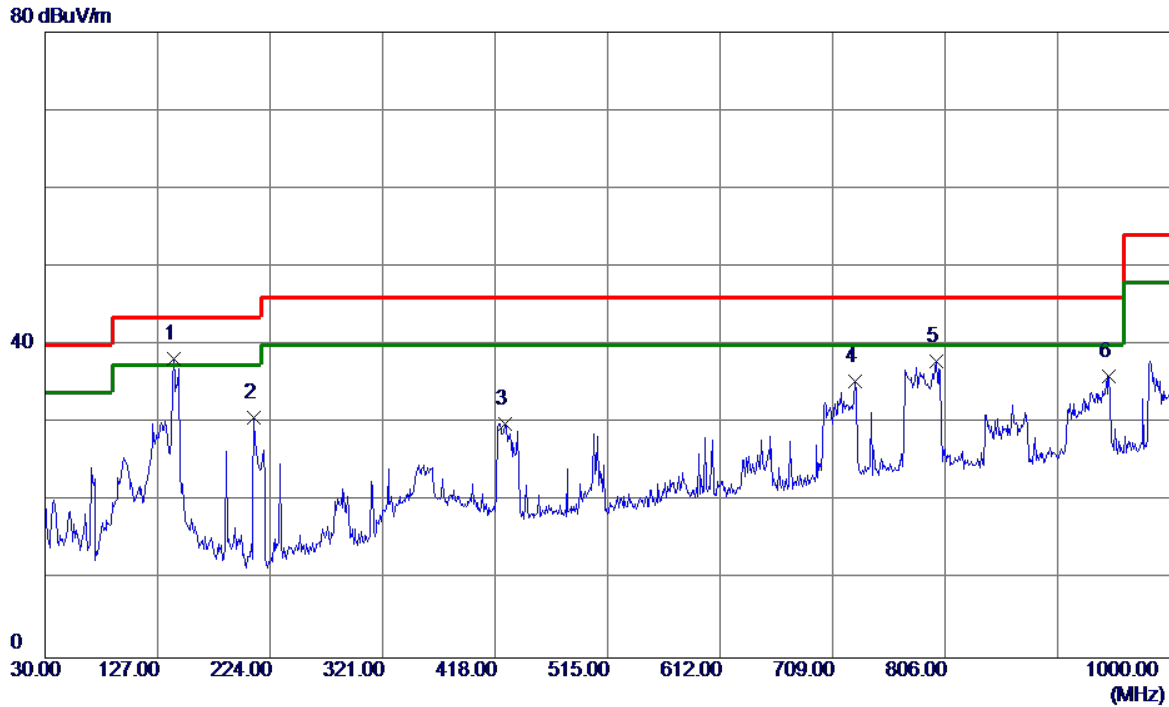

No.	Freq. MHz	Reading Level dBuV/m	Correct Factor dB	Measure ment dBuV/m	Limit dBuV/m	Margin dB	Detector
1 *	140.5800	54.60	-16.40	38.20	43.50	-5.30	QP
2	210.4200	49.31	-18.63	30.68	43.50	-12.82	QP
3	426.7300	41.58	-11.62	29.96	46.00	-16.04	QP
4	728.4000	41.18	-5.80	35.38	46.00	-10.62	QP
5	798.2400	42.68	-4.79	37.89	46.00	-8.11	QP
6	947.6200	38.71	-2.65	36.06	46.00	-9.94	QP

Test Voltage	AC 120V/60Hz	Polarization	Horizontal
Test Mode	Display 1920*1080/75Hz 1.8m H		

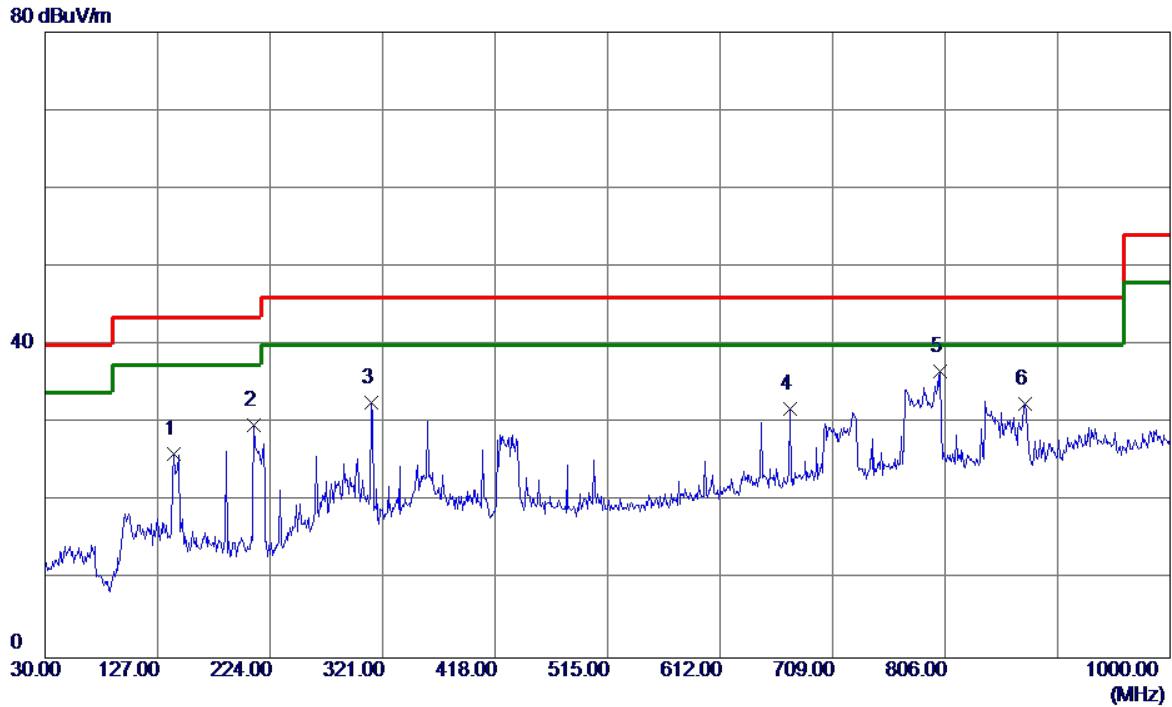

No.	Freq. MHz	Reading Level dBuV/m	Correct Factor dB	Measure ment dBuV/m	Limit dBuV/m	Margin dB	Detector
1	140.5800	42.41	-16.40	26.01	43.50	-17.49	QP
2	210.4200	48.36	-18.63	29.73	43.50	-13.77	QP
3	311.3000	47.04	-14.33	32.71	46.00	-13.29	QP
4	672.1400	38.68	-6.84	31.84	46.00	-14.16	QP
5 *	802.1200	41.42	-4.76	36.66	46.00	-9.34	QP
6	874.8700	36.54	-4.04	32.50	46.00	-13.50	QP

Test Voltage	AC 120V/60Hz	Polarization	Vertical
Test Mode	HDMI 1080P 1.8m H		

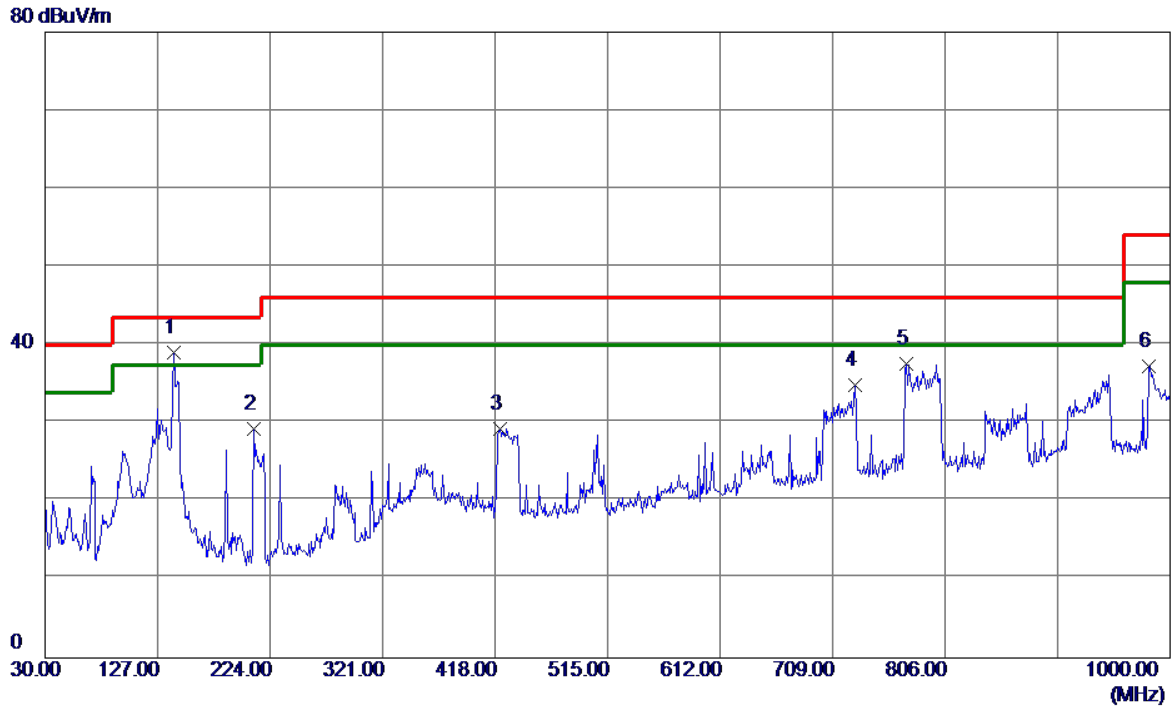

No.	Freq. MHz	Reading Level dBuV/m	Correct Factor dB	Measure ment dBuV/m	Limit dBuV/m	Margin dB	Detector
1 *	140.5800	55.50	-16.40	39.10	43.50	-4.40	QP
2	210.4200	47.86	-18.63	29.23	43.50	-14.27	QP
3	421.8800	41.10	-11.77	29.33	46.00	-16.67	QP
4	728.4000	40.62	-5.80	34.82	46.00	-11.18	QP
5	773.0200	42.76	-5.09	37.67	46.00	-8.33	QP
6	981.5700	39.51	-2.21	37.30	54.00	-16.70	QP

Test Voltage	AC 120V/60Hz	Polarization	Horizontal
Test Mode	HDMI 1080P 1.8m H		

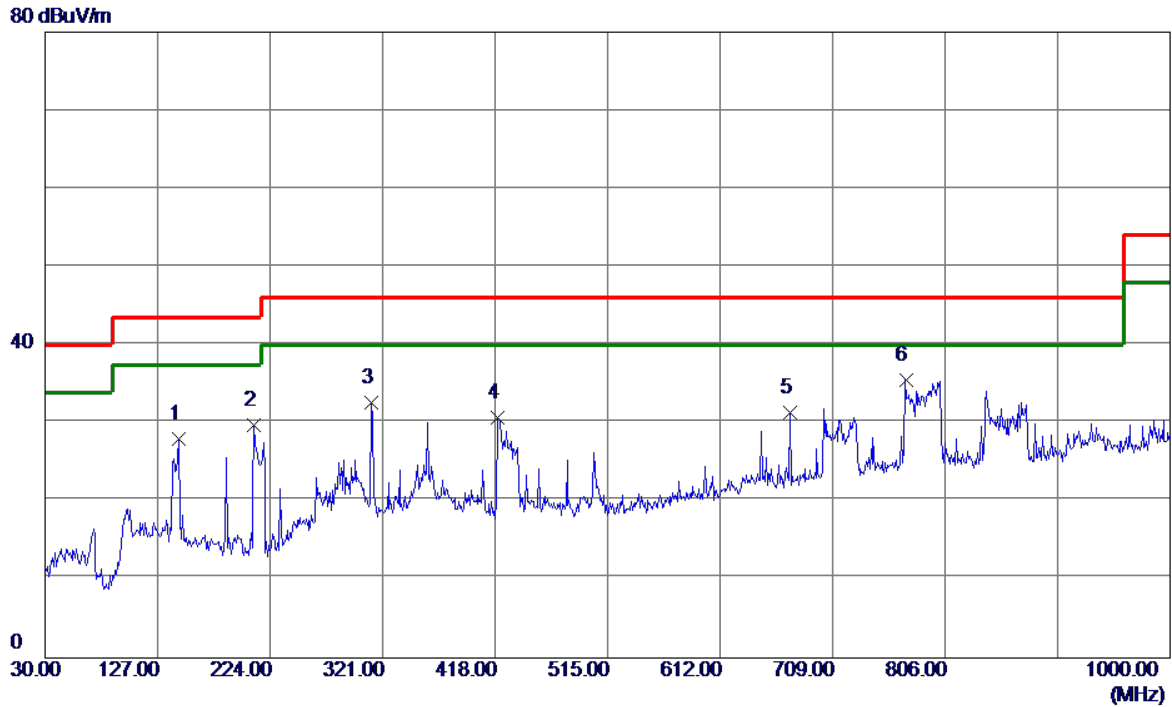

No.	Freq. MHz	Reading Level dBuV/m	Correct Factor dB	Measure ment dBuV/m	Limit dBuV/m	Margin dB	Detector
1	145.4299	44.02	-16.06	27.96	43.50	-15.54	QP
2	210.4200	48.38	-18.63	29.75	43.50	-13.75	QP
3	311.3000	46.96	-14.33	32.63	46.00	-13.37	QP
4	419.9400	42.52	-11.83	30.69	46.00	-15.31	QP
5	672.1400	38.23	-6.84	31.39	46.00	-14.61	QP
6 *	772.0500	40.61	-5.11	35.50	46.00	-10.50	QP

3.3 RADIATED EMISSIONS ABOVE 1 GHZ

3.3.1 LIMIT

Above 1 GHz

Frequency (MHz)	Class B	
	(dBuV/m) (at 3m)	
	Peak	Average
Above 1000	74	54

FREQUENCY RANGE OF RADIATED MEASUREMENT (FOR UNINTENTIONAL RADIATORS)

Highest frequency generated or Upper frequency of measurement used in the device or on which the device operates or tunes (MHz)	Range (MHz)
Below 1.705	30
1.705 - 108	1000
108 - 500	2000
500 - 1000	5000
Above 1000	5 th harmonic of the highest frequency or 40 GHz, whichever is lower

NOTE:

- (1) The tighter limit applies at the band edges.
- (2) Emission level (dBuV/m) = 20log Emission level (uV/m).
3m Emission level = 10m Emission level + 20log(10m/3m).
- (3) The test result calculated as following:
Measurement Value = Reading Level + Correct Factor
Correct Factor = Antenna Factor + Cable Loss - Amplifier Gain(if use)
Margin Level = Measurement Value - Limit Value

3.3.2 MEASUREMENT INSTRUMENTS LIST

Item	Kind of Equipment	Manufacturer	Type No.	Serial No.	Calibrated until
1	Horn Antenna	EMCO	3115	9605-4803	Mar. 23, 2020
2	Amplifier	Agilent	8449B	3008A02584	Aug. 03, 2020
3	MXE EMI Receiver	Agilent	N9038A	MY53220133	Mar. 10, 2020
4	Measurement Software	Farad	EZ-EMC Ver.BTL-2ANT-1	N/A	N/A
5	Multi-Device Controller	ETS-Lindgren	2090	N/A	N/A
6	Controller	MF	MF-7802	MF780208159	N/A
7	Cable	Mlcable Inc.	B10-01-01-5M	18047123	Mar. 01, 2020
8	Cable	Mlcable Inc.	B10-01-01-10M	18072746	Mar. 01, 2020
9	Cable	N/A	A50-3.5M3.5M-1.5M-AT	18041824	Mar. 01, 2020

Remark: "N/A" denotes no model name, no serial no. or no calibration specified.

All calibration period of equipment list is one year.

3.3.3 TEST PROCEDURE

- a. The measuring distance of 3 m shall be used for measurements. The EUT was placed on the top of a rotating table 0.8 meter above the ground at a 10 meter semi-anechoic chamber. The table was rotated 360 degrees to determine the position of the highest radiation.
- b. The height of the equipment or of the substitution antenna shall be 0.8 m, the height of the test antenna shall vary between 1 m to 4 m. Both horizontal and vertical polarizations of the antenna are set to make the measurement.
- c. For each suspected emission, the EUT was arranged to its worst case and then the antenna was tuned to heights find the maximum reading (used Bore sight function).
- d. The initial step in collecting radiated emission data is a receiver peak detector mode pre-scanning the measurement frequency range. Significant peaks are then marked and then Quasi Peak detector mode re-measured.
- e. The receiver system was set to peak and average detect function and specified bandwidth with maximum hold mode when the test frequency is above 1 GHz.
- f. All readings are Peak Mode value unless otherwise stated AVG in column of Note. If the Peak Mode Measured value compliance with the Peak Limits and lower than AVG Limits, the EUT shall be deemed to meet both Peak & AVG Limits and then only Peak Mode was measured, but AVG Mode didn't perform.
- g. For the actual test configuration, please refer to the related Item - Block Diagram of system tested.

3.3.4 DEVIATION FROM TEST STANDARD

No deviation

3.3.5 TEST SETUP

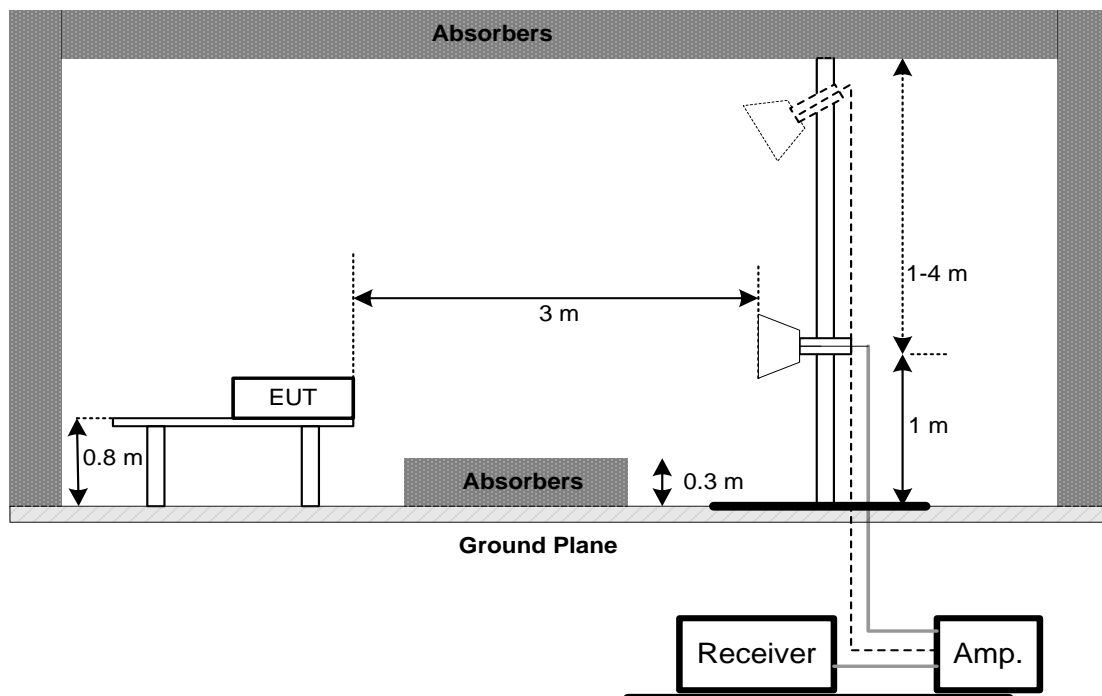

3.3.6 TEST RESULTS-ABOVE 1 GHZ

Remark :

- (1) Radiated emissions measured in frequency range above 1000 MHz were made with an instrument using Peak detector mode and AV detector mode of the emission.
- (2) Data of measurement within this frequency range shown “ * ” in the table above means the reading of emissions are attenuated more than 20 dB below the permissible limits or the field strength is too small to be measured.
- (3) A preamp and high pass filter were used for this test in order to provide sufficient measurement sensitivity.

Test Voltage	AC 120V/60Hz	Polarization	Vertical
Test Mode	HDMI 1920*1080/75Hz 1.8m H		

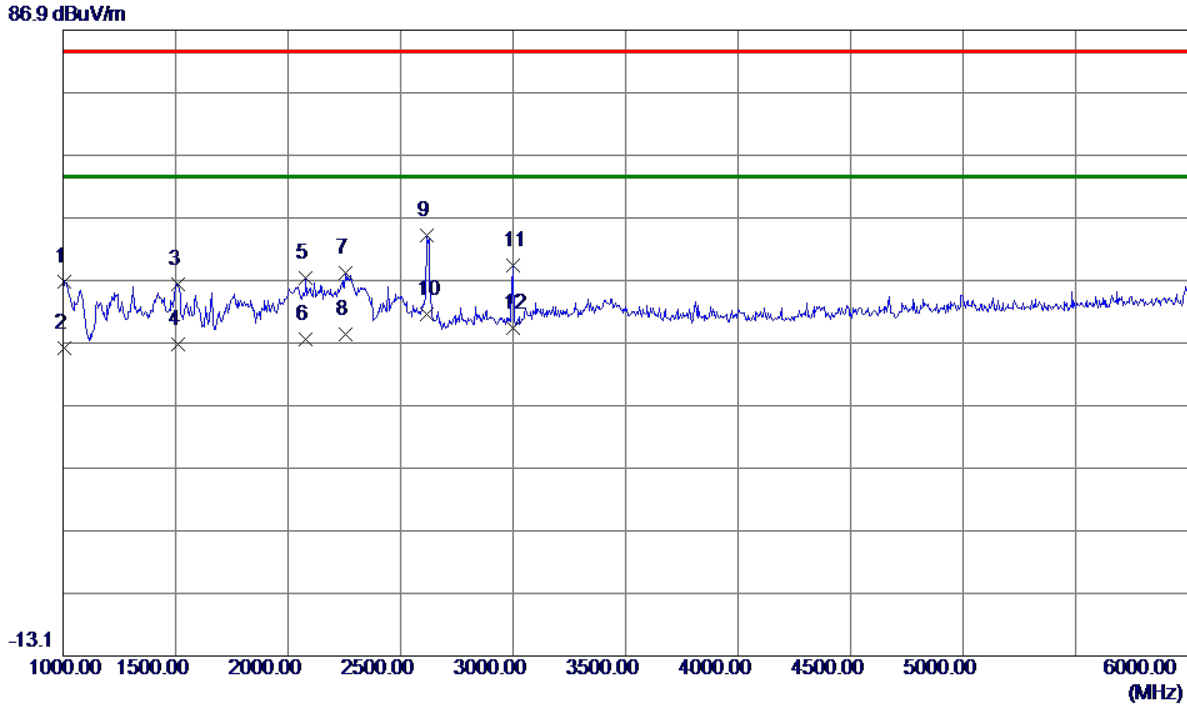

No.	Freq. MHz	Reading Level dBuV/m	Correct Factor dB	Measure ment dBuV/m	Limit dBuV/m	Margin dB	Detector
1	1007.5000	53.83	-7.03	46.80	83.50	-36.70	Peak
2	1007.5000	43.17	-7.03	36.14	63.50	-27.36	AVG
3	1510.0000	50.05	-3.70	46.35	83.50	-37.15	Peak
4	1510.0000	40.42	-3.70	36.72	63.50	-26.78	AVG
5	2080.0000	49.06	-1.74	47.32	83.50	-36.18	Peak
6	2080.0000	39.23	-1.74	37.49	63.50	-26.01	AVG
7	2257.5000	49.11	-1.06	48.05	83.50	-35.45	Peak
8	2257.5000	39.37	-1.06	38.31	63.50	-25.19	AVG
9	2617.5000	53.82	0.20	54.02	83.50	-29.48	Peak
10 *	2617.5000	41.34	0.20	41.54	63.50	-21.96	AVG
11	2997.5000	48.11	1.25	49.36	83.50	-34.14	Peak
12	2997.5000	37.96	1.25	39.21	63.50	-24.29	AVG

Test Voltage	AC 120V/60Hz	Polarization	Horizontal
Test Mode	HDMI 1920*1080/75Hz 1.8m H		

86.9 dBuV/m

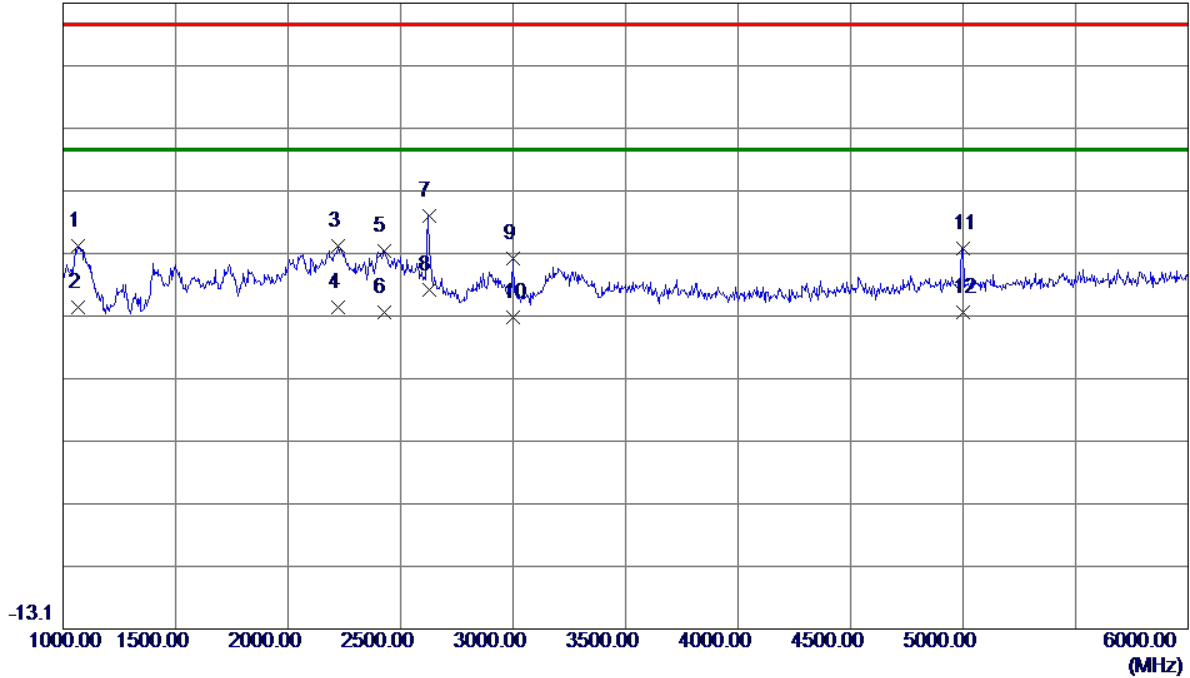

No.	Freq. MHz	Reading Level dBuV/m	Correct Factor dB	Measure ment dBuV/m	Limit dBuV/m	Margin dB	Detector
1	1067.5000	54.79	-6.63	48.16	83.50	-35.34	Peak
2	1067.5000	44.88	-6.63	38.25	63.50	-25.25	AVG
3	2222.5000	49.31	-1.20	48.11	83.50	-35.39	Peak
4	2222.5000	39.57	-1.20	38.37	63.50	-25.13	AVG
5	2425.0000	47.70	-0.42	47.28	83.50	-36.22	Peak
6	2425.0000	37.87	-0.42	37.45	63.50	-26.05	AVG
7	2625.0000	52.69	0.22	52.91	83.50	-30.59	Peak
8 *	2625.0000	40.97	0.22	41.19	63.50	-22.31	AVG
9	2997.5000	44.81	1.25	46.06	83.50	-37.44	Peak
10	2997.5000	35.40	1.25	36.65	63.50	-26.85	AVG
11	5000.0000	40.60	7.17	47.77	83.50	-35.73	Peak
12	5000.0000	30.32	7.17	37.49	63.50	-26.01	AVG

Test Voltage	AC 120V/60Hz	Polarization	Vertical
Test Mode	Display 1920*1080/75Hz 1.8m H		

86.9 dBuV/m

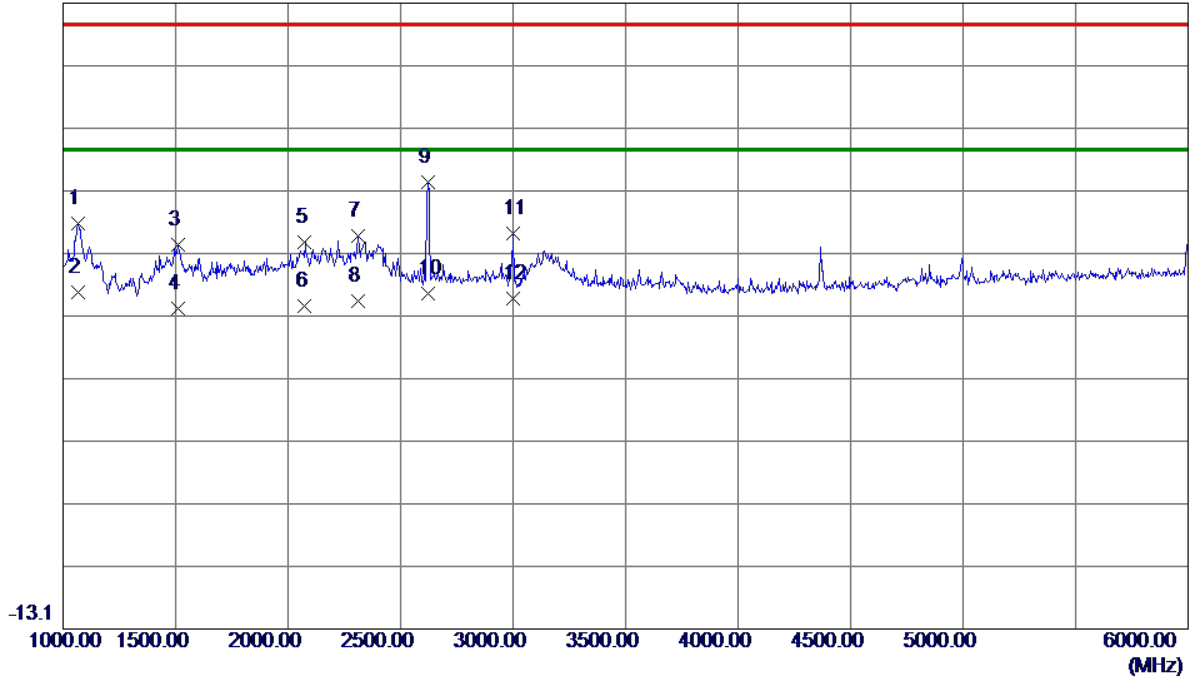

No.	Freq. MHz	Reading Level dBuV/m	Correct Factor dB	Measure ment dBuV/m	Limit dBuV/m	Margin dB	Detector
1	1065.0000	58.36	-6.64	51.72	83.50	-31.78	Peak
2 *	1065.0000	47.31	-6.64	40.67	63.50	-22.83	AVG
3	1510.0000	51.96	-3.70	48.26	83.50	-35.24	Peak
4	1510.0000	41.85	-3.70	38.15	63.50	-25.35	AVG
5	2075.0000	50.55	-1.76	48.79	83.50	-34.71	Peak
6	2075.0000	40.17	-1.76	38.41	63.50	-25.09	AVG
7	2310.0000	50.50	-0.86	49.64	83.50	-33.86	Peak
8	2310.0000	40.13	-0.86	39.27	63.50	-24.23	AVG
9	2620.0000	58.17	0.20	58.37	83.50	-25.13	Peak
10	2620.0000	40.29	0.20	40.49	63.50	-23.01	AVG
11	3000.0000	48.84	1.26	50.10	83.50	-33.40	Peak
12	3000.0000	38.37	1.26	39.63	63.50	-23.87	AVG

Test Voltage	AC 120V/60Hz	Polarization	Horizontal
Test Mode	Display 1920*1080/75Hz 1.8m H		

86.9 dBuV/m

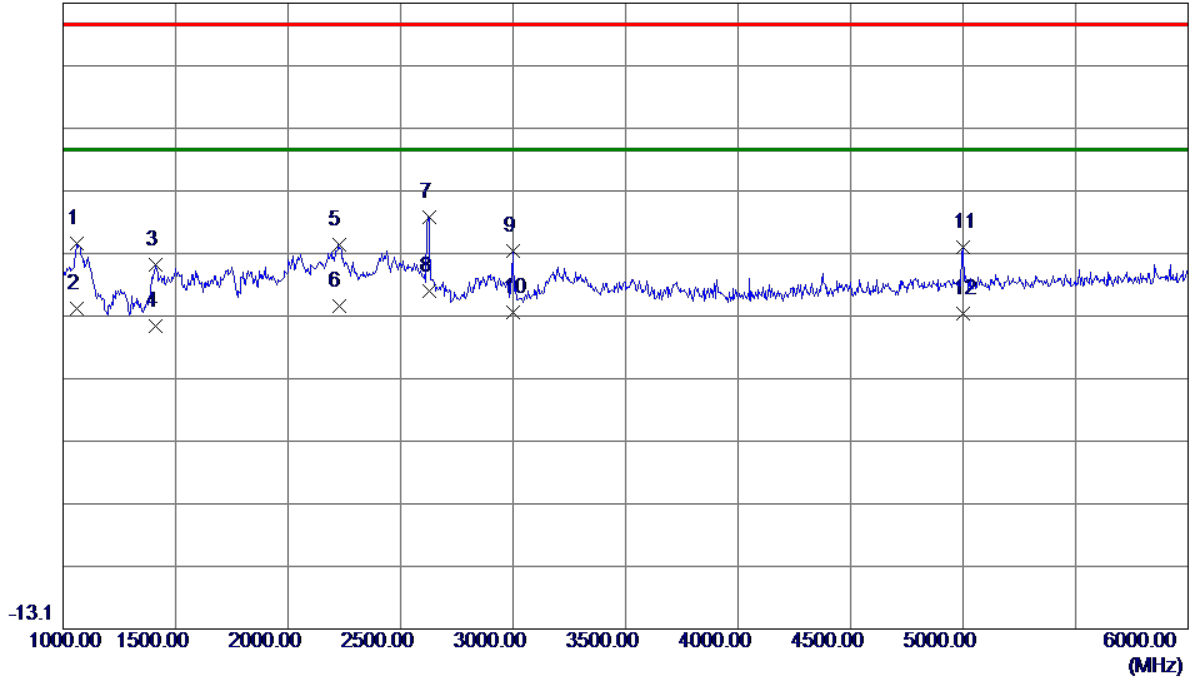

No.	Freq. MHz	Reading Level dBuV/m	Correct Factor dB	Measure ment dBuV/m	Limit dBuV/m	Margin dB	Detector
1	1062.5000	55.19	-6.66	48.53	83.50	-34.97	Peak
2	1062.5000	44.79	-6.66	38.13	63.50	-25.37	AVG
3	1412.5000	49.40	-4.32	45.08	83.50	-38.42	Peak
4	1412.5000	39.61	-4.32	35.29	63.50	-28.21	AVG
5	2225.0000	49.43	-1.19	48.24	83.50	-35.26	Peak
6	2225.0000	39.65	-1.19	38.46	63.50	-25.04	AVG
7	2627.5000	52.50	0.22	52.72	83.50	-30.78	Peak
8 *	2627.5000	40.75	0.22	40.97	63.50	-22.53	AVG
9	2997.5000	46.10	1.25	47.35	83.50	-36.15	Peak
10	2997.5000	36.23	1.25	37.48	63.50	-26.02	AVG
11	4997.5000	40.82	7.16	47.98	83.50	-35.52	Peak
12	4997.5000	30.21	7.16	37.37	63.50	-26.13	AVG

Test Voltage	AC 120V/60Hz	Polarization	Vertical
Test Mode	HDMI 1080P 1.8m H		

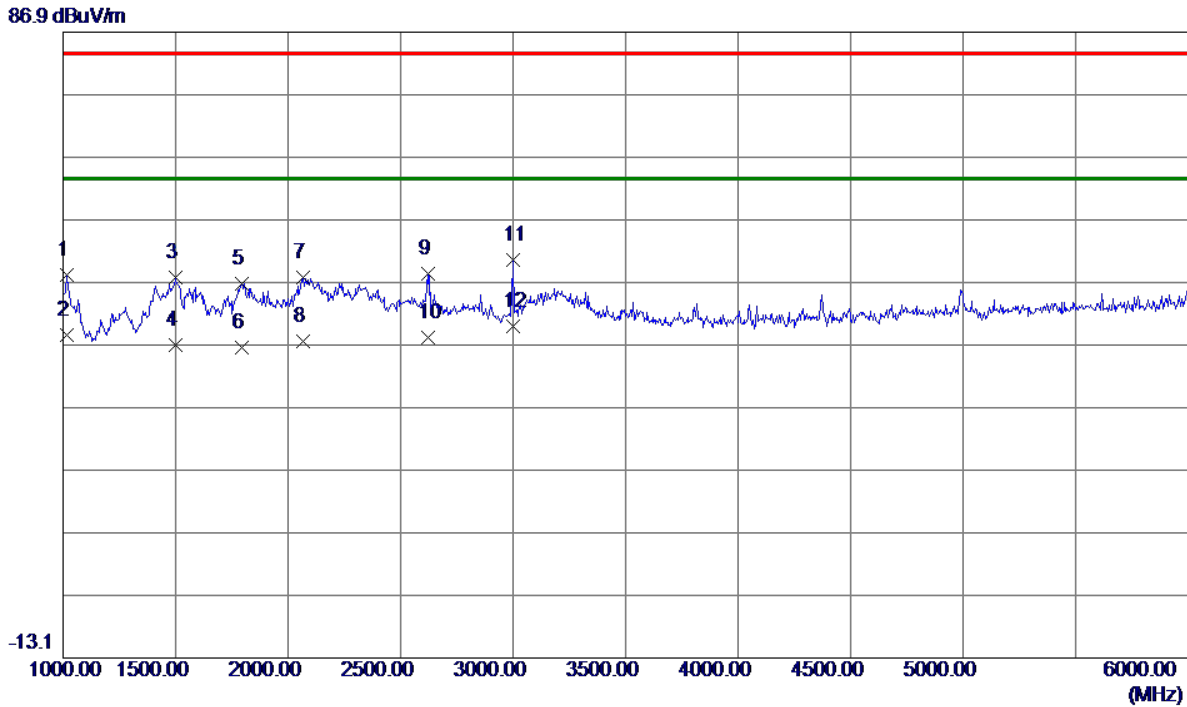

No.	Freq. MHz	Reading Level dBuV/m	Correct Factor dB	Measure ment dBuV/m	Limit dBuV/m	Margin dB	Detector
1	1017.5000	54.98	-6.96	48.02	83.50	-35.48	Peak
2	1017.5000	45.38	-6.96	38.42	63.50	-25.08	AVG
3	1497.5000	51.49	-3.75	47.74	83.50	-35.76	Peak
4	1497.5000	40.72	-3.75	36.97	63.50	-26.53	AVG
5	1792.5000	49.45	-2.75	46.70	83.50	-36.80	Peak
6	1792.5000	39.28	-2.75	36.53	63.50	-26.97	AVG
7	2065.0000	49.41	-1.80	47.61	83.50	-35.89	Peak
8	2065.0000	39.26	-1.80	37.46	63.50	-26.04	AVG
9	2622.5000	48.17	0.21	48.38	83.50	-35.12	Peak
10	2622.5000	37.94	0.21	38.15	63.50	-25.35	AVG
11	3000.0000	49.26	1.26	50.52	83.50	-32.98	Peak
12 *	3000.0000	38.63	1.26	39.89	63.50	-23.61	AVG

Test Voltage	AC 120V/60Hz	Polarization	Horizontal
Test Mode	HDMI 1080P 1.8m H		

86.9 dBuV/m

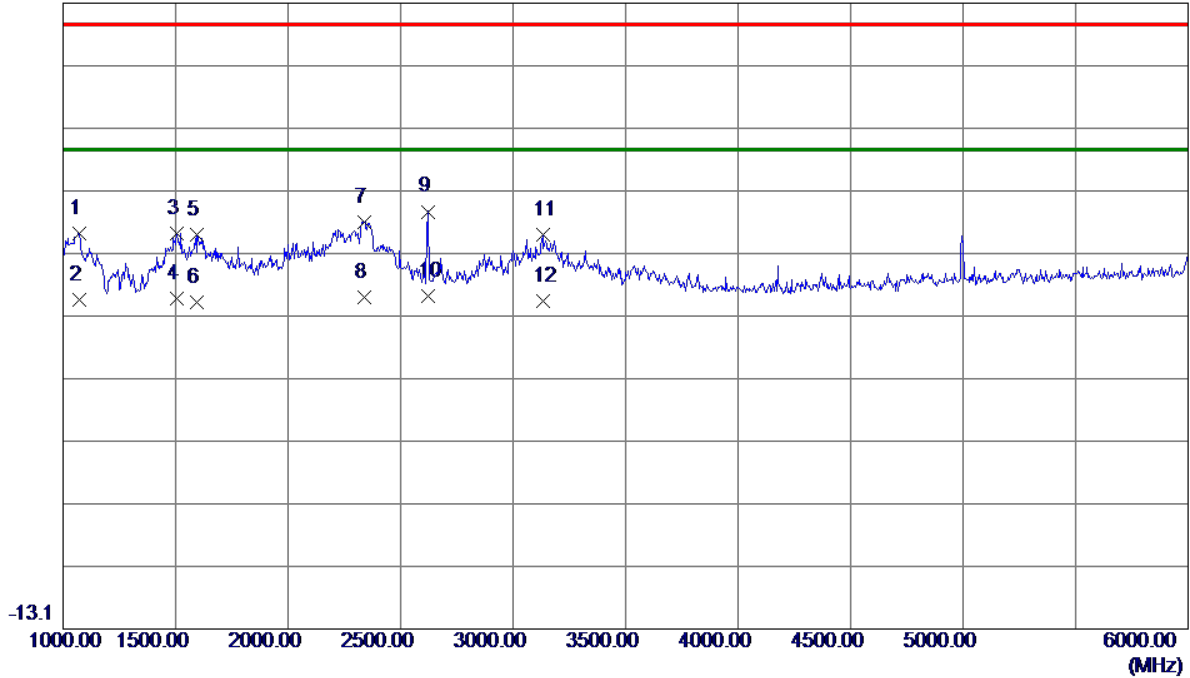

No.	Freq. MHz	Reading Level dBuV/m	Correct Factor dB	Measure ment dBuV/m	Limit dBuV/m	Margin dB	Detector
1	1070.0000	56.73	-6.61	50.12	83.50	-33.38	Peak
2	1070.0000	46.13	-6.61	39.52	63.50	-23.98	AVG
3	1507.5000	53.86	-3.70	50.16	83.50	-33.34	Peak
4	1507.5000	43.37	-3.70	39.67	63.50	-23.83	AVG
5	1595.0000	53.24	-3.41	49.83	83.50	-33.67	Peak
6	1595.0000	42.57	-3.41	39.16	63.50	-24.34	AVG
7	2337.5000	52.70	-0.75	51.95	83.50	-31.55	Peak
8	2337.5000	40.64	-0.75	39.89	63.50	-23.61	AVG
9	2622.5000	53.39	0.21	53.60	83.50	-29.90	Peak
10 *	2622.5000	39.96	0.21	40.17	63.50	-23.33	AVG
11	3132.5000	48.24	1.70	49.94	83.50	-33.56	Peak
12	3132.5000	37.68	1.70	39.38	63.50	-24.12	AVG

4. EUT TEST PHOTO

AC Power Line Conducted Emissions



Radiated Emissions 30 MHz to 1 GHz

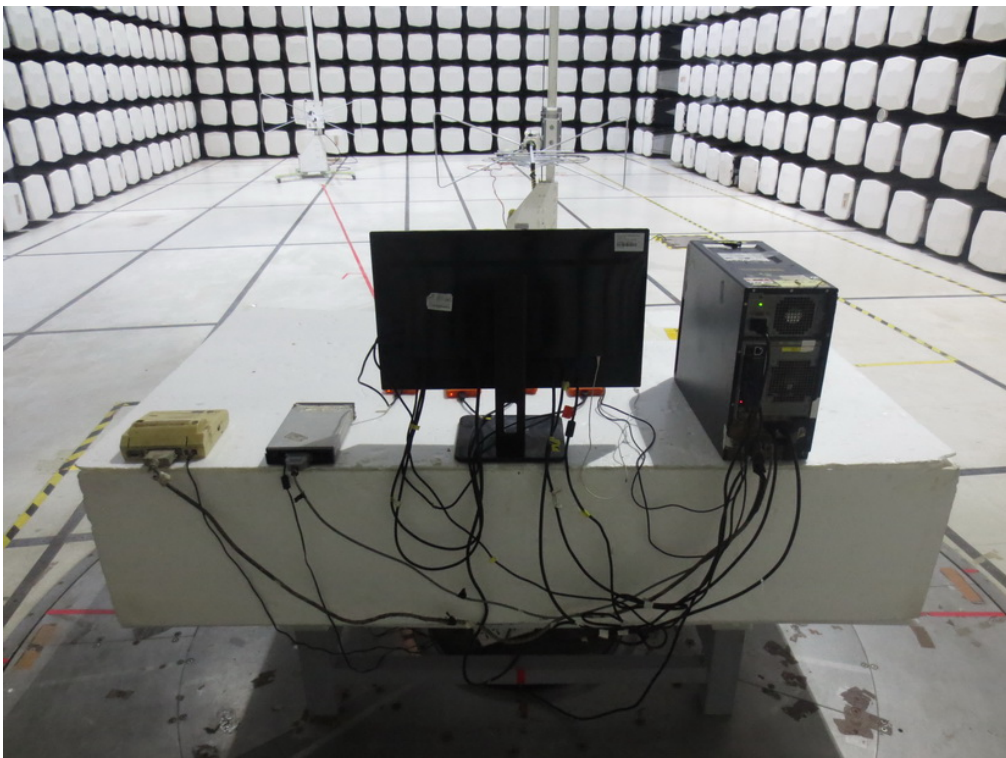

Radiated Emissions Above 1 GHz

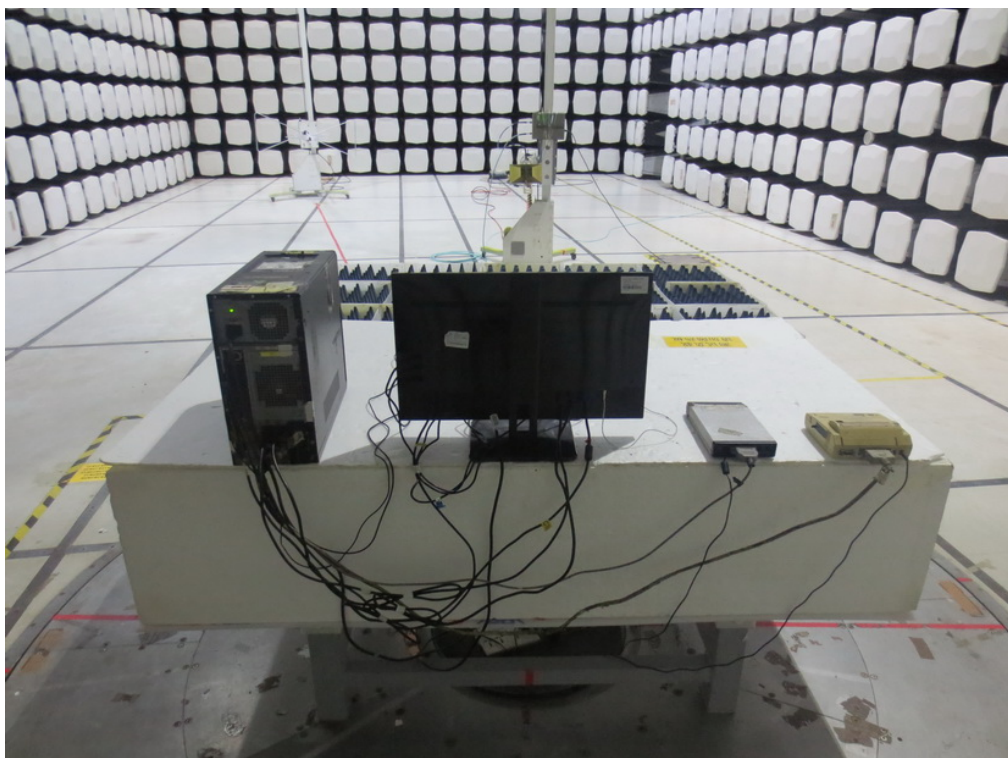
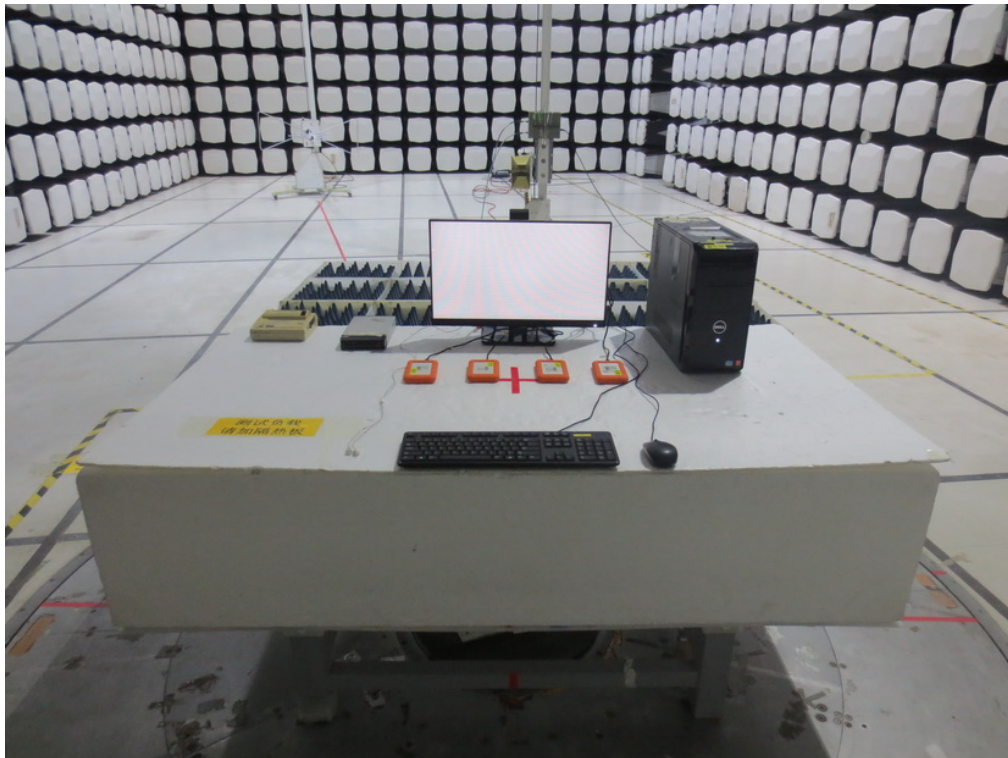
**End of Test Report**