



FCC DOC TEST REPORT

Applicant : TPV Electronics (Fujian) Co., Ltd.
Address : Rongqiao Economic and Technological
Development Zone, Fuqing City, Fujian Province,
P.R. China
Equipment : LCD Monitor
Model No. : 27V2;**27V2*****
(The "*" could be any alphanumeric character
including blank for marketing differentiation.)

I HEREBY CERTIFY THAT :

The sample was received on Apr. 02, 2018 and the testing was carried out on Apr.13, 2018 at CerpPASS Technology Corp. The test result refers exclusively to the test presented test model / sample. Without written approval of CerpPASS Technology Corp., the test report shall not be reproduced except in full.

Approved by:

Kero / EMC & RF Manager

Laboratory Accreditation:

CerpPASS Technology Corporation Test Laboratory





Contents

1. Summary of Test Procedure and Test Result.....	4
1.1. Applicable Standards	4
Test Configuration of Equipment under Test.....	5
1.2. Feature of Equipment under Test.....	5
1.3. Test Manner	5
1.4. Description of Test System.....	7
1.5. General Information of Test.....	8
1.6. Measurement Uncertainty	8
2. Test of Conducted Emission.....	9
2.1. Test Limit	9
2.2. Test Procedures	9
2.3. Typical test Setup.....	10
2.4. Measurement Equipment.....	10
2.5. Test Result and Data.....	11
2.6. Test Photographs	15
3. Test of Radiated Emission	17
3.1. Test Limit	17
3.2. Test Procedures	18
3.3. Typical test Setup.....	18
3.4. Measurement Equipment.....	19
3.5. Test Result and Data (30MHz ~ 1GHz).....	20
3.6. Test Result and Data (1GHz ~ 18GHz).....	24
3.7. Test Photographs (30MHz~1GHz).....	28
3.8. Test Photographs (1GHz~18GHz).....	30



1. Summary of Test Procedure and Test Result

1.1. Applicable Standards

FCC

The measurements shown in this test report were made in accordance with the procedures given in ANSI C63.4 – 2014 and the energy emitted by this equipment was passed Part 2, Part 15, CISPR PUB. 22.

Canada

The measurements shown in this test report were made in accordance with the procedures given in Canada ICES-003 issue 6 section 3.a and 3.b.

The energy emitted by this equipment was passed both Radiated and Conducted Emissions Class **B** limits.

Test Item	Normative References	Test Result	Remarks
Conducted Emission	ANSI C63.4-2014, FCC Part 15 Subpart B, KDB174176, Canada ICES-003 issue 6	PASS	Meets Class B Limit Minimum passing margin(QP) is -12.67 dB at 0.1860 MHz
Radiated Emission	ANSI C63.4-2014, FCC Part 15 Subpart B, KDB174176, Canada ICES-003 issue 6	PASS	Meets Class B Limit Minimum passing margin(Peak) Is -6.04 dB at 30.00 MHz



Test Configuration of Equipment under Test

1.2. Feature of Equipment under Test

LCD Monitor	Model No.	27V2;**27V2***** (The “*” could be any alphanumeric character including blank for marketing differentiation.)
Adapter	Model No.:	STK030-19158T
	Input:	AC 100-240V~ 50/60Hz Max. 0.8A
	Output:	DC 19V,1.58A
Power Cable	Non-Shielding, 1.2m&1.5m&1.8m	
Please refer to the user's manual.		

1.3. Test Manner

27V2Q

- During testing, the interface cables and equipment positions were varied according to ANSI C63.4.
- The complete test system included PC, Keyboard, Mouse, Printer, iPod, Earphone and EUT for EMI test.
- An executive program, “BURNIN.EXE & MyHwin” under WIN 8, which generates a complete line of continuously repeating “H” pattern were used as the test software.
The program was executed as follows:
 - Turn on the power of all equipment.
 - The PC reads the test program from the hard disk drive and runs it.
 - The PC sends “H” messages to the EUT, and the EUT displays “H” patterns on the screen.
 - The PC sends “H” messages to the internal Hard Disk, and the Hard Disk reads and writes the message.
 - The PC sends “H” messages to the printer, then the printer prints them on the paper.
 - Repeat the steps from 2 to 5.
- The maximum operating frequency is above 108MHz, the test frequency range is from 30MHz to 18GHz.

- The test modes of EMI test as follow:

Conducted Emissions from the AC mains power ports & Radiation Emissions	
Test Mode	Operating Description
Test Mode 1	Full system (Display mode 1920*1080@60Hz) Signal from PC
Test Mode 2	Full system (Display mode 1280*1024@75Hz) Signal from PC
Test Mode 3	Full system (Display mode 640*480@60Hz) Signal from PC
Test Mode 4	Full system (HDMI mode 1920*1080@60Hz) Signal from PC
Test Mode 5	Full system (HDMI mode 1280*1024@75Hz) Signal from PC
Test Mode 6	Full system (HDMI mode 640*480@60Hz) Signal from PC
Test Mode 7	Full system (HDMI mode 1080P) Signal from DVD
caused “Test Mode 1” generates the worst case, they were reported as the final data.	



27V2H

- a. During testing, the interface cables and equipment positions were varied according to ANSI C63.4.
- b. The complete test system included PC, Keyboard, Mouse, Printer, iPod, Earphone and EUT for EMI test.
- c. An executive program, "BURNIN.EXE & MyHwin" under WIN 8, which generates a complete line of continuously repeating "H" pattern were used as the test software.
The program was executed as follows:
 - 1. Turn on the power of all equipment.
 - 2. The PC reads the test program from the hard disk drive and runs it.
 - 3. The PC sends "H" messages to the EUT, and the EUT displays "H" patterns on the screen.
 - 4. The PC sends "H" messages to the internal Hard Disk, and the Hard Disk reads and writes the message.
 - 5. The PC sends "H" messages to the printer, then the printer prints them on the paper.
 - 6. Repeat the steps from 2 to 5.
- d. The maximum operating frequency is above 108MHz, the test frequency range is from 30MHz to 18GHz.

e. The test modes of EMI test as follow:

Conducted Emissions from the AC mains power ports & Radiation Emissions	
Test Mode	Operating Description
Test Mode 1	Full system (VGA mode 1920*1080@60Hz) Signal from PC
Test Mode 2	Full system (VGA mode 1280*1024@75Hz) Signal from PC
Test Mode 3	Full system (VGA mode 640*480@60Hz) Signal from PC
Test Mode 4	Full system (HDMI mode 1920*1080@60Hz) Signal from PC
Test Mode 5	Full system (HDMI mode 1280*1024@75Hz) Signal from PC
Test Mode 6	Full system (HDMI mode 640*480@60Hz) Signal from PC
Test Mode 7	Full system (HDMI mode 1080P) Signal from DVD

caused "Test Mode 1" generates the worst case, they were reported as the final data.



1.4. Description of Test System

27V2Q

PC	DELL	XPS8700	Power Cable, Non-Shielded, 1.8m
Keyboard	DELL	SK-8175	Data Cable, USB Shielding 1.85m
Mouse	DELL	MS111-P	Data Cable, USB Shielding 1.85m
Printer	HP	P1102w	Power Cable, Non-Shielded 1.8m Data Cable, USB Shielding 1.6m
iPod	APPLE	A1320	Data Cable, USB Shielding 1.0m
Earphone	APPLE	EarPods	Data Cable, Audio Non-Shielded 1.35m

Use Cable:

Cable	Quantity	Description
Display	1	Shielding, 1.2m&1.5m&1.8m
HDMI	1	Shielding, 1.2m&1.5m&1.8m

27V2H

PC	DELL	XPS8700	Power Cable, Non-Shielded, 1.8m
Keyboard	DELL	SK-8175	Data Cable, USB Shielding 1.85m
Mouse	DELL	MS111-P	Data Cable, USB Shielding 1.85m
Printer	HP	P1102w	Power Cable, Non-Shielded 1.8m Data Cable, USB Shielding 1.6m
iPod	APPLE	A1320	Data Cable, USB Shielding 1.0m
Earphone	APPLE	EarPods	Data Cable, Audio Non-Shielded 1.35m

Use Cable:

Cable	Quantity	Description
VGA	1	Shielded, 1.2m&1.5m&1.8m, with two ferrites core bonded
HDMI	1	Shielding, 1.2m&1.5m&1.8m

**1.5. General Information of Test**

Test Site :	Cerpass Technology Corporation Test Laboratory Address: No.10, Ln. 2, Lianfu St., Luzhu Dist., Taoyuan City 33848, Taiwan (R.O.C.) Tel:+886-3-3226-888 Fax:+886-3-3226-881 Address: No.68-1, Shihbachongsi, Shihding Township, New Taipei City 223, Taiwan, R.O.C. Tel: +886-2-2663-8582
FCC Registration Number :	TW1079, TW1061, TW1439
IC Registration Number :	4934E-1, 4934E-2
VCCI	T-2205 for Telecommunication Test C-4663 for Conducted emission test R-4218 for Radiated emission test G-10812 for radiated disturbance above 1GHz
Frequency Range Investigated :	Conducted Emission Test: from 150 kHz to 30 MHz Radiated Emission Test: from 30 MHz to 18,000 MHz
Test Distance :	The test distance of radiated emission below 1GHz from antenna to EUT is 10 M. The test distance of radiated emission above 1GHz from antenna to EUT is 3 M.

1.6. Measurement Uncertainty

Measurement Item	Measurement Frequency	Polarization	Uncertainty
Conducted Emission	9 kHz ~ 30 MHz	LINE / NEUTRAL	± 3.25 dB
Radiated Emission	30 MHz ~ 1,000 MHz	Vertical / Horizontal	± 3.93 dB
	1,000 MHz ~ 6,000 MHz	Vertical / Horizontal	± 4.01 dB
	6,000 MHz ~ 18,000 MHz	Vertical / Horizontal	± 4.72 dB



2. Test of Conducted Emission

2.1. Test Limit

Conducted Emissions were measured from 150 kHz to 30 MHz with a bandwidth of 9 KHz on the 120 VAC power and return leads of the EUT according to the methods defined in ANSI C63.4-2014. The EUT was placed on a nonmetallic stand in a shielded room 0.8 meters above the ground plane as shown in section 2.2. The interface cables and equipment positioning were varied within limits of reasonable applications to determine the position produced maximum conducted emissions.

Conducted Emission Limits:

Frequency (MHz)	Quasi Peak (dB μ V)	Average (dB μ V)
0.15 – 0.5	66-56*	56-46*
0.5 – 5.0	56	46
5.0 – 30.0	60	50

2.2. Test Procedures

- The EUT was placed 0.4 meter from the conducting wall of the shielding room was kept at least 80 centimeters from any other grounded conducting surface.
- Connect EUT to the power mains through a line impedance stabilization network (LISN).
- All the support units are connecting to the other LISN.
- The LISN provides 50 ohm coupling impedance for the measuring instrument.
- The FCC states that a 50 ohm, 50 micro-Henry LISN should be used.
- Both sides of AC line were checked for maximum conducted interference.
- The frequency range from 150 kHz to 30 MHz was searched.
- Set the test-receiver system to Peak Detect Function and Specified Bandwidth with Maximum Hold Mode.

2.3. Typical test Setup

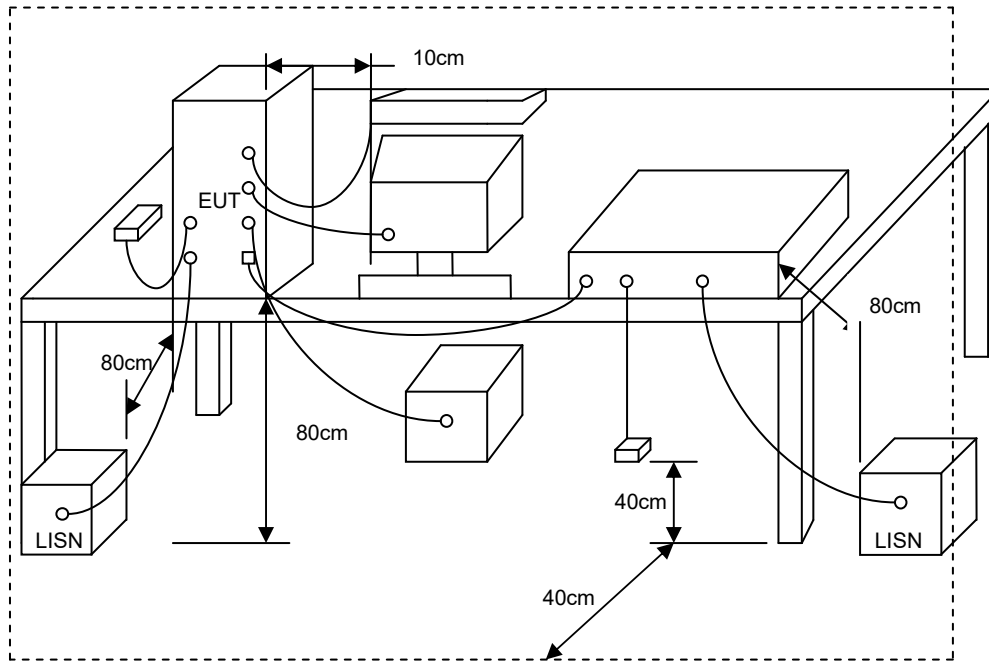

2.4. Measurement Equipment

Instrument	Manufacturer	Model No	Serial No	Calibration Date	Valid Date
EMI Receiver	R&S	ESCI3	100821	2017/09/08	2018/09/07
Line Impedance Stabilization Network	Schwarzbeck	NSLK 8127	8127-516	2017/09/12	2018/09/11
Line Impedance Stabilization Network	Schwarzbeck	NSLK 8127	8127-568	2018/02/26	2019/02/25
Pulse Limiter	R&S	ESH3-Z2	101934	2018/02/22	2019/02/21
Software	Farad	Ez-EMC	ver.ct3a1	N/A	N/A



2.5. Test Result and Data

27V2Q

Power	: AC 120V	Pol/Phase	: LINE
Test Mode	: Mode 1	Temperature	: 26 °C
Test Date	: Apr. 12, 2018	Humidity	: 45 %
Model No.	: 27V2Q	Atmospheric Pressure	: 1008 hPa

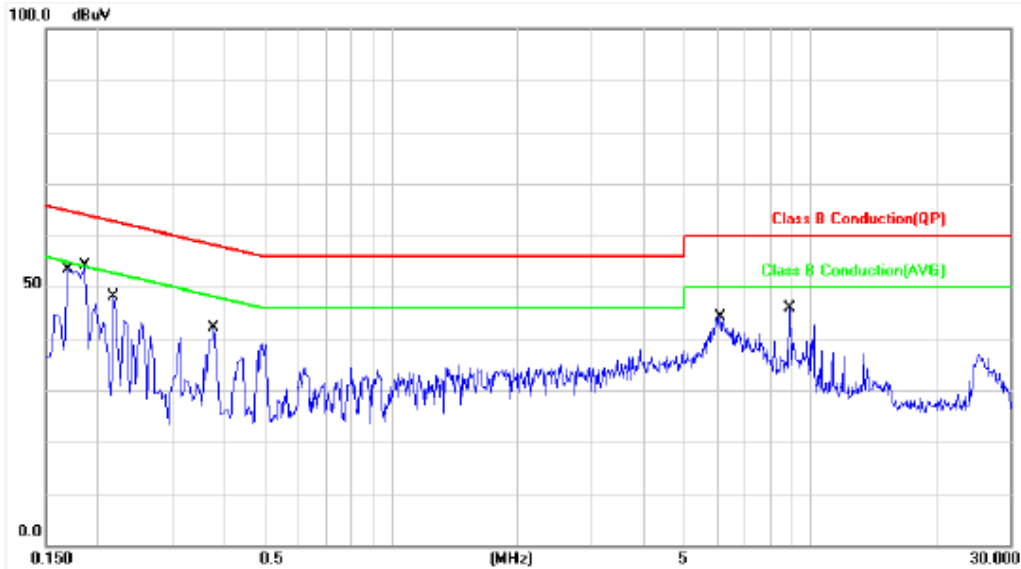

No.	Frequency (MHz)	Factor (dB)	Reading (dBuV)	Level (dBuV)	Limit (dBuV)	Margin (dB)	Detector	P/F
1	0.1700	9.94	41.00	50.94	64.96	-14.02	QP	P
2	0.1700	9.94	22.78	32.72	54.96	-22.24	AVG	P
3	0.1860	9.94	41.60	51.54	64.21	-12.67	QP	P
4	0.1860	9.94	27.22	37.16	54.21	-17.05	AVG	P
5	0.2180	9.94	24.61	34.55	62.89	-28.34	QP	P
6	0.2180	9.94	12.25	22.19	52.89	-30.70	AVG	P
7	0.3780	9.96	28.16	38.12	58.32	-20.20	QP	P
8	0.3780	9.96	21.40	31.36	48.32	-16.96	AVG	P
9	6.1140	10.22	28.81	39.03	60.00	-20.97	QP	P
10	6.1140	10.22	20.62	30.84	50.00	-19.16	AVG	P
11	8.9500	10.28	20.63	30.91	60.00	-29.09	QP	P
12	8.9500	10.28	13.59	23.87	50.00	-26.13	AVG	P

Note: Level=Reading+Factor.

Margin=Level-Limit.

Factor=(LISN or ISN or PLC or Current Probe)Factor+Cable Loss+Attenuator



Power	: AC 120V	Pol/Phase	: NEUTRAL
Test Mode	: Mode 1	Temperature	: 26 °C
Test Date	: Apr. 12, 2018	Humidity	: 45 %
Model No.	: 27V2Q	Atmospheric Pressure	: 1008 hPa

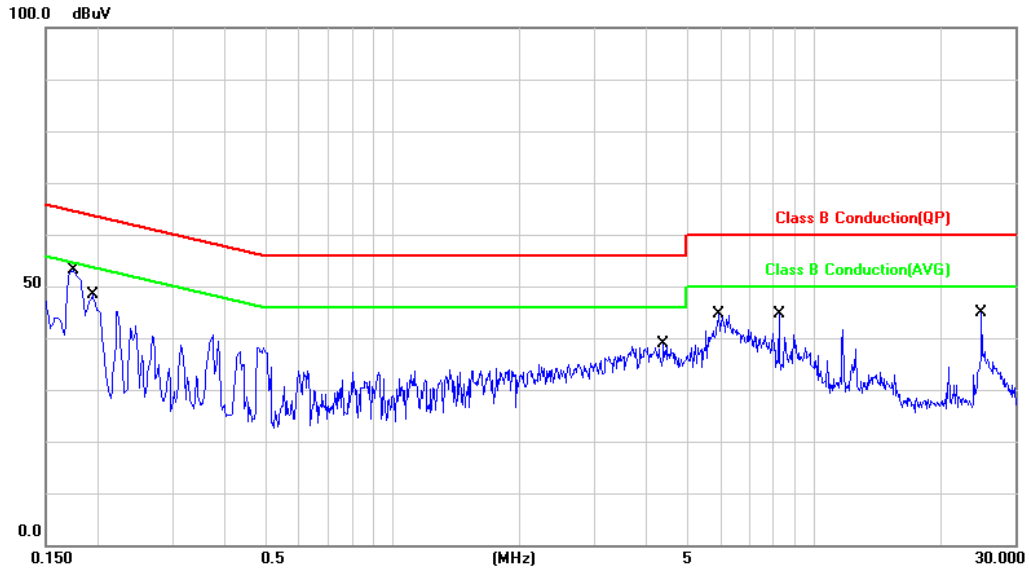

No.	Frequency (MHz)	Factpr (dB)	Reading (dBuV)	Level (dBuV)	Limit (dBuV)	Margin (dB)	Detector	P/F
1	0.1740	9.94	40.03	49.97	64.76	-14.79	QP	P
2	0.1740	9.94	23.37	33.31	54.76	-21.45	AVG	P
3	0.1940	9.94	35.47	45.41	63.86	-18.45	QP	P
4	0.1940	9.94	21.20	31.14	53.86	-22.72	AVG	P
5	4.3940	10.15	22.01	32.16	56.00	-23.84	QP	P
6	4.3940	10.15	13.75	23.90	46.00	-22.10	AVG	P
7	5.9380	10.20	28.57	38.77	60.00	-21.23	QP	P
8	5.9380	10.20	20.71	30.91	50.00	-19.09	AVG	P
9	8.2780	10.26	20.42	30.68	60.00	-29.32	QP	P
10	8.2780	10.26	13.14	23.40	50.00	-26.60	AVG	P
11	24.9860	10.79	20.94	31.73	60.00	-28.27	QP	P
12	24.9860	10.79	13.97	24.76	50.00	-25.24	AVG	P

Note: Level=Reading+Factor.

Margin=Level-Limit.

Factor=(LISN or ISN or PLC or Current Probe)Factor+Cable Loss+Attenuator



27V2H

Power	: AC 120V	Pol/Phase	: LINE
Test Mode	: Mode 1	Temperature	: 26 °C
Test Date	: Apr. 12, 2018	Humidity	: 45 %
Model No.	: 27V2H	Atmospheric Pressure	: 1008 hPa

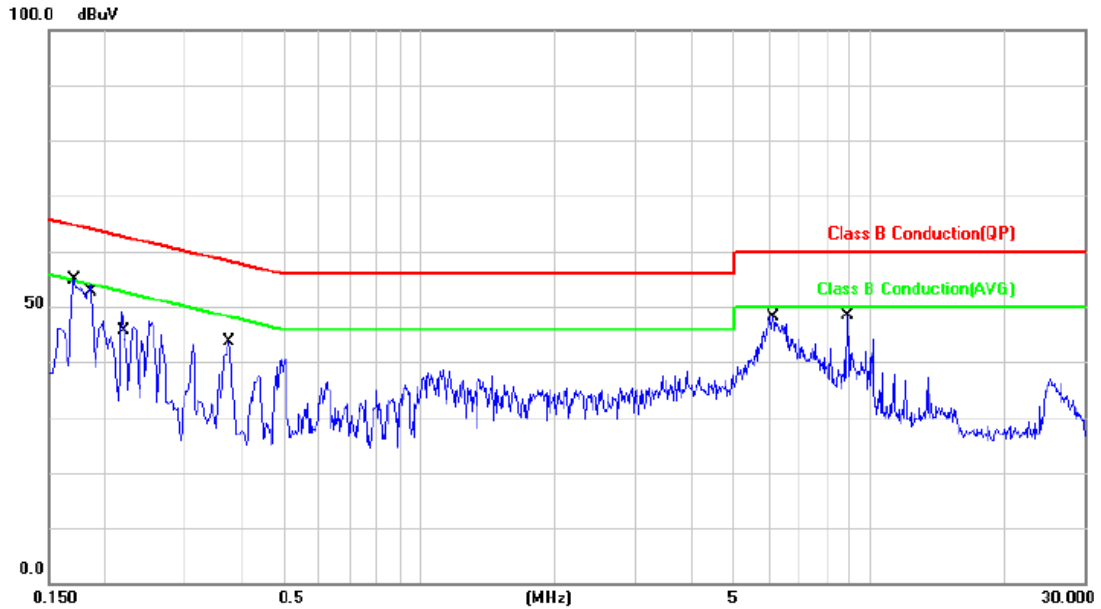

No.	Frequency (MHz)	Factor (dB)	Reading (dBuV)	Level (dBuV)	Limit (dBuV)	Margin (dB)	Detector	P/F
1	0.1720	9.94	40.80	50.74	64.86	-14.12	QP	P
2	0.1720	9.94	21.93	31.87	54.86	-22.99	AVG	P
3	0.1880	9.94	40.27	50.21	64.12	-13.91	QP	P
4	0.1880	9.94	27.13	37.07	54.12	-17.05	AVG	P
5	0.2210	9.94	24.30	34.24	62.78	-28.54	QP	P
6	0.2210	9.94	12.24	22.18	52.78	-30.60	AVG	P
7	0.3800	9.96	28.28	38.24	58.28	-20.04	QP	P
8	0.3800	9.96	21.28	31.24	48.28	-17.04	AVG	P
9	6.1120	10.22	28.72	38.94	60.00	-21.06	QP	P
10	6.1120	10.22	20.54	30.76	50.00	-19.24	AVG	P
11	8.9540	10.28	20.59	30.87	60.00	-29.13	QP	P
12	8.9540	10.28	13.16	23.44	50.00	-26.56	AVG	P

Note: Level=Reading+Factor.

Margin=Level-Limit.

Factor=(LISN or ISN or PLC or Current Probe)Factor+Cable Loss+Attenuator



Power	: AC 120V	Pol/Phase	: NEUTRAL
Test Mode	: Mode 1	Temperature	: 26 °C
Test Date	: Apr. 12, 2018	Humidity	: 45 %
Model No.	: 27V2H	Atmospheric Pressure	: 1008 hPa

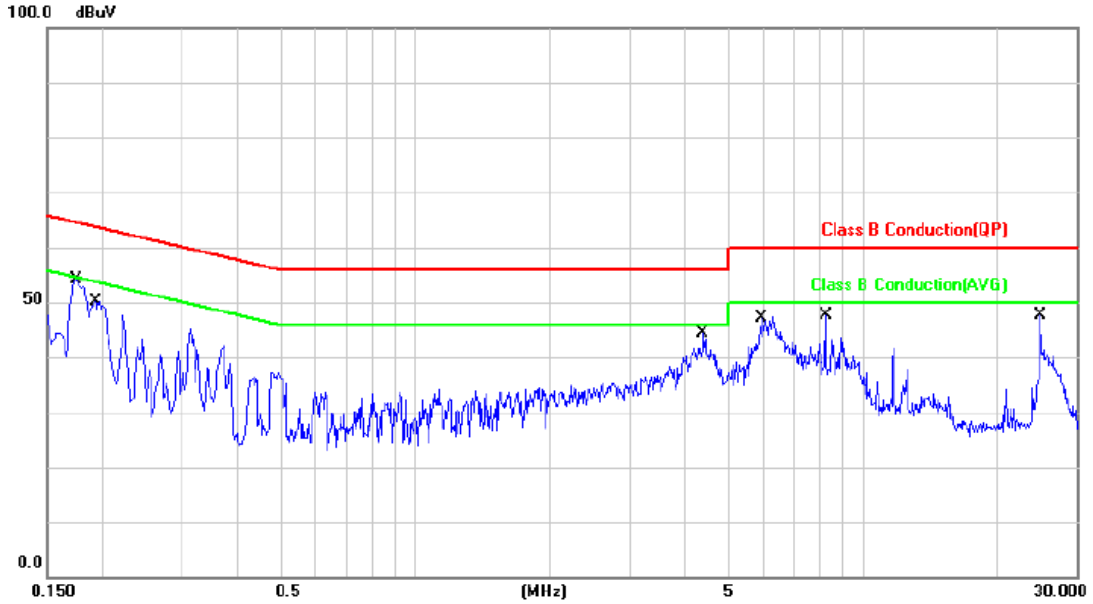

No.	Frequency (MHz)	Factor (dB)	Reading (dBuV)	Level (dBuV)	Limit (dBuV)	Margin (dB)	Detector	P/F
1	0.1720	9.94	39.93	49.87	64.86	-14.99	QP	P
2	0.1720	9.94	23.60	33.54	54.86	-21.32	AVG	P
3	0.1920	9.94	35.20	45.14	63.95	-18.81	QP	P
4	0.1920	9.94	21.17	31.11	53.95	-22.84	AVG	P
5	4.3400	10.15	21.82	31.97	56.00	-24.03	QP	P
6	4.3400	10.15	13.42	23.57	46.00	-22.43	AVG	P
7	5.9340	10.20	28.46	38.66	60.00	-21.34	QP	P
8	5.9340	10.20	20.68	30.88	50.00	-19.12	AVG	P
9	8.2800	10.26	20.28	30.54	60.00	-29.46	QP	P
10	8.2800	10.26	13.16	23.42	50.00	-26.58	AVG	P
11	24.9900	10.71	20.18	30.89	60.00	-29.11	QP	P
12	24.9900	10.71	13.79	24.50	50.00	-25.50	AVG	P

Note: Level=Reading+Factor.

Margin=Level-Limit.

Factor=(LISN or ISN or PLC or Current Probe)Factor+Cable Loss+Attenuator

Test engineer: Ken



2.6. Test Photographs

27V2Q

Front View



Rear View





27V2H

Front View



Rear View





3. Test of Radiated Emission

3.1. Test Limit

Radiated emissions from 30 MHz to 18,000 MHz were measured according to the methods defines in ANSI C63.4-2014. The EUT was placed on a nonmetallic stand in the Chamber, 0.8 meter above the ground plane. The interface cables and equipment positions were varied within limits of reasonable applications to determine the positions producing maximum radiated emissions.

For unintentional device, according to §15.109, except for Class A digital devices, the field strength of radiated emissions from unintentional radiators at a distance of 3 meters shall not exceed the following values:

Class B Radiated Emission limit at 3m

Frequency (MHz)	Distance Meters	Radiated ($\mu V / M$)	Radiated (dB $\mu V / M$)
30-88	3	100	40.0
88-216	3	150	43.5
216-960	3	200	46.0
Above 960	3	500	54.0

Frequency (MHz)	Average (dBuV/m)	Peak (dBuV/m)
Above 1000	54	74

Class A Radiated Emission limit at 10m

Frequency (MHz)	Distance Meters	Radiated ($\mu V / M$)	Radiated (dB $\mu V / M$)
30-88	10	90	39
88-216	10	150	43.5
216-960	10	210	46.4
Above 960	10	300	49.5

Frequency (MHz)	Average (dBuV/m)	Peak (dBuV/m)
Above 1000	60	80

NOTE: (1) The lower limit shall apply at the transition frequencies.

(2) Emission level (dBuV/m) = 20 log Emission level (uV/m).

3.2. Test Procedures

- a. The EUT was placed on a Rota table top 0.8 meter above ground.
- b. The EUT was set 3/10 meters from the interference receiving antenna which was mounted on the top of a variable height antenna tower.
- c. The table was rotated 360 degrees to determine the position of the highest radiation.
- d. The antenna is a half wave dipole and its height is varied between one meter and four meters above ground to find the maximum value of the field strength both horizontal polarization and vertical polarization of the antenna are set to make the measurement.
- e. For each suspected emission the EUT was arranged to its worst case and then tune the antenna tower (from 1 M to 4 M) and turn table (from 0 degree to 360 degrees) to find the maximum reading.
- f. Set the test-receiver system to Peak Detect Function and specified bandwidth with Maximum Hold Mode.
- g. If the emission level of the EUT in peak mode was 6 dB lower than the limit specified, then testing will be stopped and peak values of EUT will be reported, otherwise, the emissions which do not have 6 dB margin will be repeated one by one using the quasi-peak method and reported.

3.3. Typical test Setup

Below 1GHz Test Setup

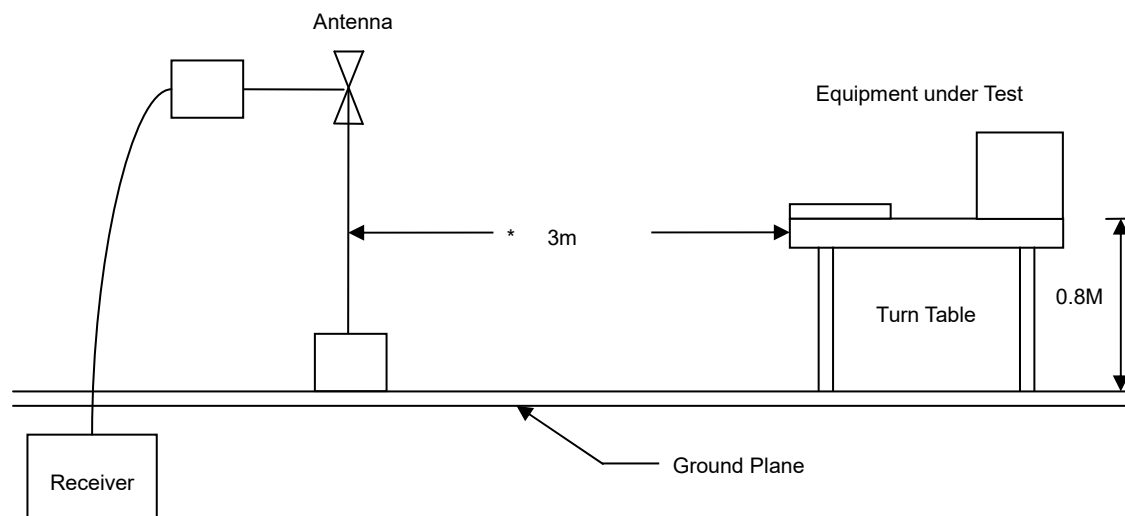

Above 1GHz Test Setup

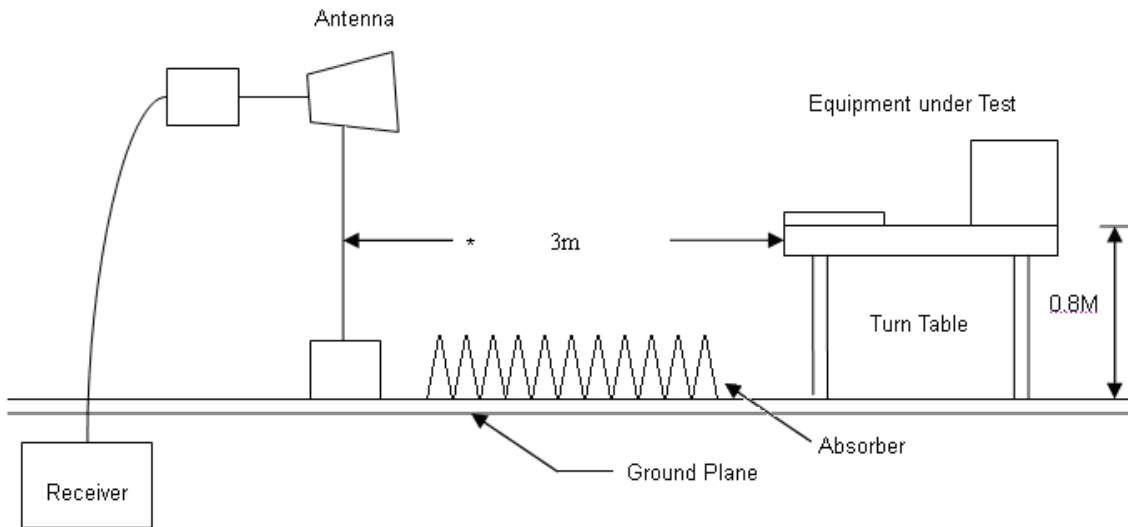

3.4. Measurement Equipment

Instrument	Manufacturer	Model No.	Serial No.	Calibration Date	Valid Date
Bilog Antenna	Sunol	JB1	A020514-1	2018/02/13	2019/02/12
Bilog Antenna	Sunol	JB1	A020514-2	2018/03/15	2019/03/14
EMI Receiver	R&S	ESCI3	101402	2018/02/13	2019/02/12
EMI Receiver	R&S	ESCI7	100963	2018/03/06	2019/03/05
Preamplifier	EM Electronics corp.	EM330	60610	2018/02/25	2019/02/24
Preamplifier	EM Electronics corp.	EM330	60611	2018/02/10	2019/02/09
Horn Antenna	Schwarzbeck	BBHA 9120 D	9120D-1785	2017/09/27	2018/09/26
Spectrum Analyzer	R&S	FSP40	100047	2018/02/13	2019/02/12
Preamplifier	EM Electronics corp.	EM01G18G	60700	2017/09/01	2018/08/31
Software	E3	AUDIX	Version: 8.14.806b	N/A	N/A



3.5. Test Result and Data (30MHz ~ 1GHz)

27V2Q

Power	: AC 120V	Pol/Phase	: VERTICAL
Test Mode	: Mode 1	Temperature	: 21 °C
Test Date	: Apr. 13, 2018	Humidity	: 41 %
Model No.	: 27V2Q	Atmospheric Pressure	: 1011 hPa

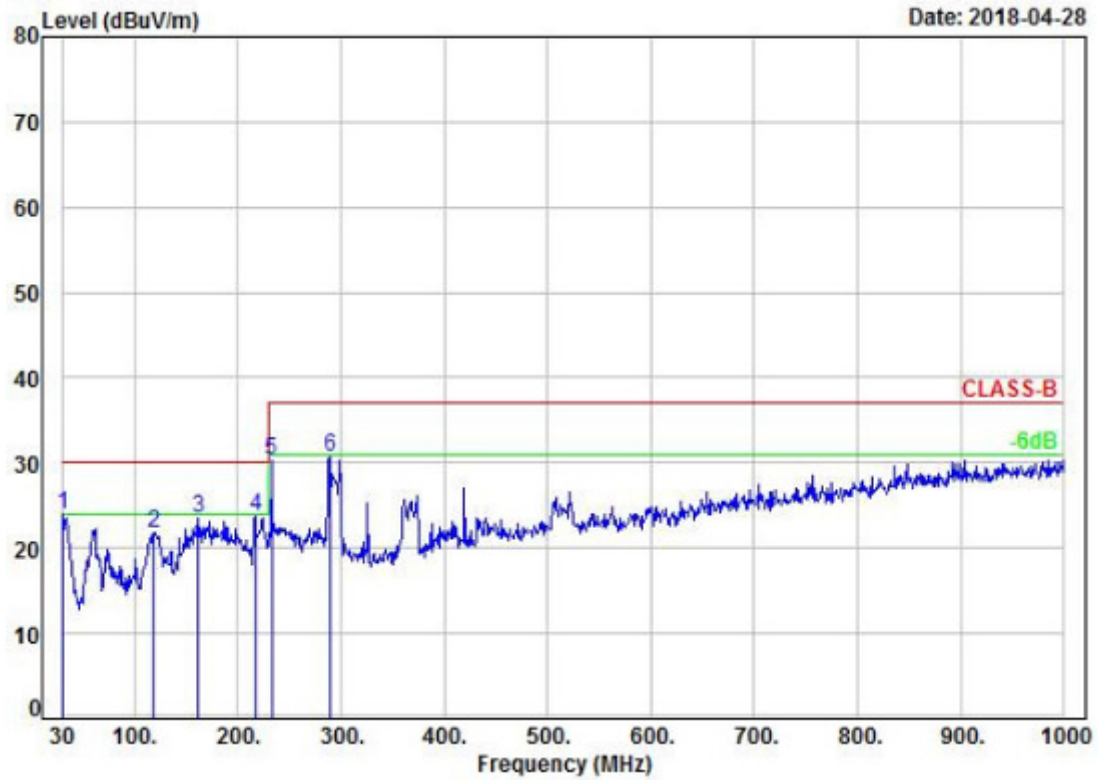

No.	Frequency (MHz)	Factor (dB/m)	Reading (dBuV)	Level (dBuV/m)	Limit (dBuV/m)	Margin (dB)	Detector	Height (cm)	Azimuth (deg)	P/F
1	30.00	-2.48	26.44	23.96	30.00	-6.04	Peak	100	0	P
2	118.27	-9.63	31.51	21.88	30.00	-8.12	Peak	100	0	P
3	160.95	-10.96	34.43	23.47	30.00	-6.53	Peak	100	0	P
4	217.21	-11.97	35.76	23.79	30.00	-6.21	Peak	100	0	P
5	232.73	-11.18	41.41	30.23	37.00	-6.77	Peak	100	0	P
6	289.96	-8.95	39.64	30.69	37.00	-6.31	Peak	100	0	P

Note: Level=Reading+Factor
Margin=Level-Limit
Factor=Antenna Factor + cable loss - Amplifier Factor



Power	: AC 120V	Pol/Phase	: HORIZONTAL
Test Mode	: Mode 1	Temperature	: 21 °C
Test Date	: Apr. 13, 2018	Humidity	: 41 %
Model No.	: 27V2Q	Atmospheric Pressure	: 1011 hPa

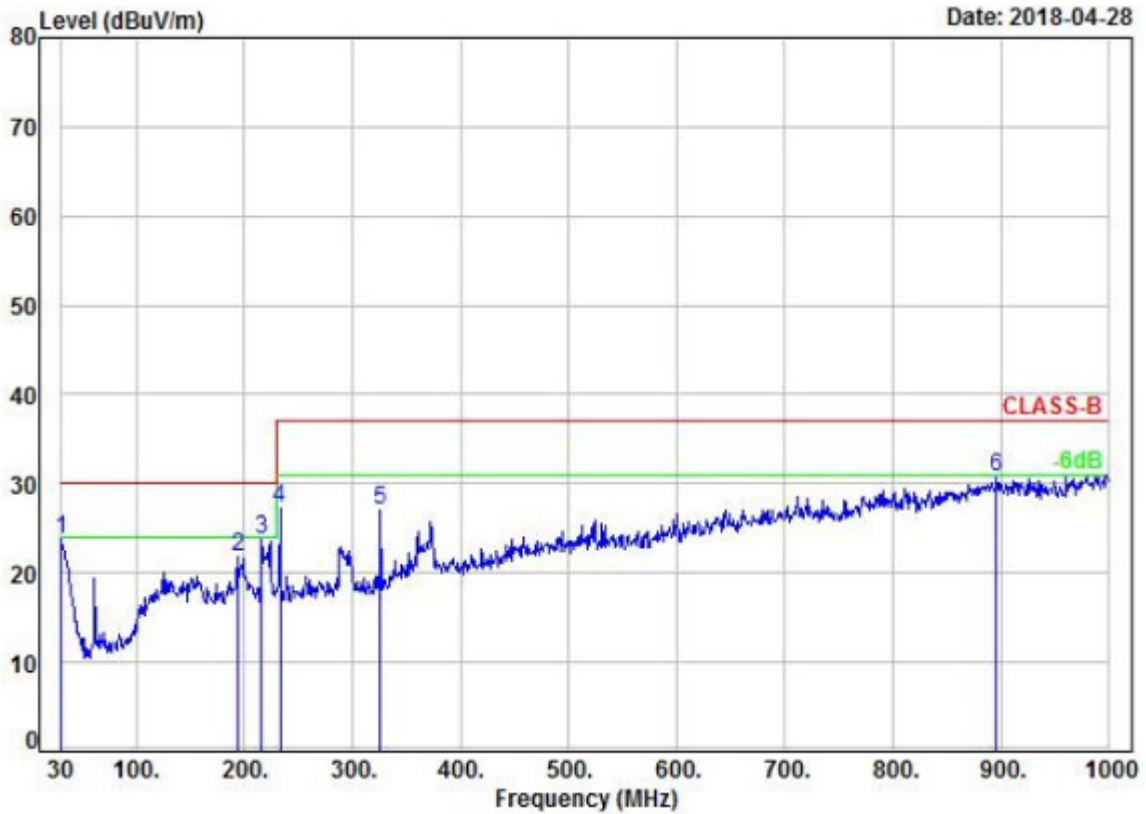

No.	Frequency (MHz)	Factor (dB/m)	Reading (dBuV)	Level (dBuV/m)	Limit (dBuV/m)	Margin (dB)	Detector	Height (cm)	Azimuth (deg)	P/F
1	30.00	-2.34	26.02	23.68	30.00	-6.32	Peak	100	0	P
2	194.90	-10.32	32.17	21.85	30.00	-8.15	Peak	100	0	P
3	216.24	-11.52	35.24	23.72	30.00	-6.28	Peak	100	0	P
4	232.73	-10.68	38.01	27.33	37.00	-9.67	Peak	100	0	P
5	325.85	-7.43	34.38	26.95	37.00	-10.05	Peak	100	0	P
6	896.21	4.30	26.41	30.71	37.00	-6.29	Peak	100	0	P

Note: Level=Reading+Factor
Margin=Level-Limit
Factor=Antenna Factor + cable loss - Amplifier Factor



27V2H

Power	: AC 120V	Pol/Phase	: VERTICAL
Test Mode	: Mode 1	Temperature	: 21 °C
Test Date	: Apr. 13, 2018	Humidity	: 41 %
Model No.	: 27V2H	Atmospheric Pressure	: 1011 hPa

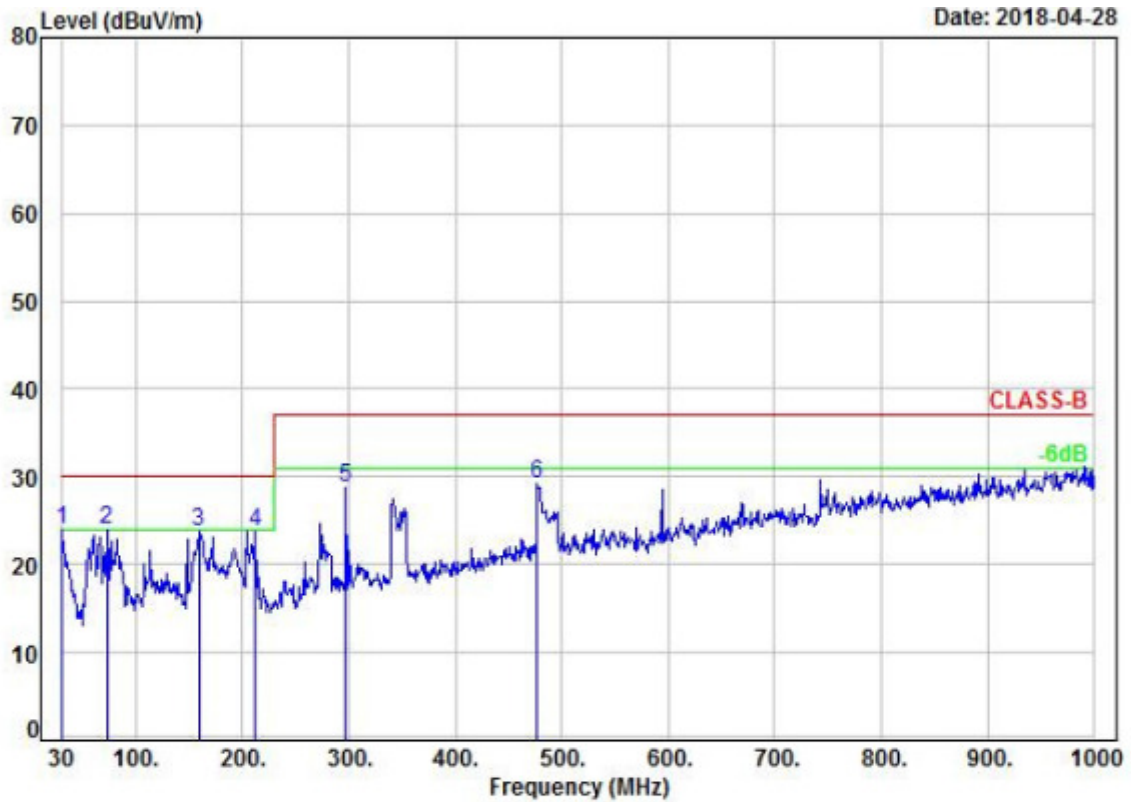

No.	Frequency (MHz)	Factor (dB/m)	Reading (dBuV)	Level (dBuV/m)	Limit (dBuV/m)	Margin (dB)	Detector	Height (cm)	Azimuth (deg)	P/F
1	30.00	-2.48	26.40	23.92	30.00	-6.08	Peak	400	0	P
2	72.68	-15.61	39.53	23.92	30.00	-6.08	Peak	400	0	P
3	159.01	-10.92	34.61	23.69	30.00	-6.31	Peak	400	0	P
4	212.36	-12.17	35.95	23.78	30.00	-6.22	Peak	400	0	P
5	296.75	-8.89	37.63	28.74	37.00	-8.26	Peak	400	0	P
6	477.17	-3.69	32.85	29.16	37.00	-7.84	Peak	400	0	P

Note: Level=Reading+Factor
Margin=Level-Limit
Factor=Antenna Factor + cable loss - Amplifier Factor



Power	: AC 120V	Pol/Phase	: HORIZONTAL
Test Mode	: Mode 1	Temperature	: 21 °C
Test Date	: Apr. 13, 2018	Humidity	: 41 %
Model No.	: 27V2H	Atmospheric Pressure	: 1011 hPa

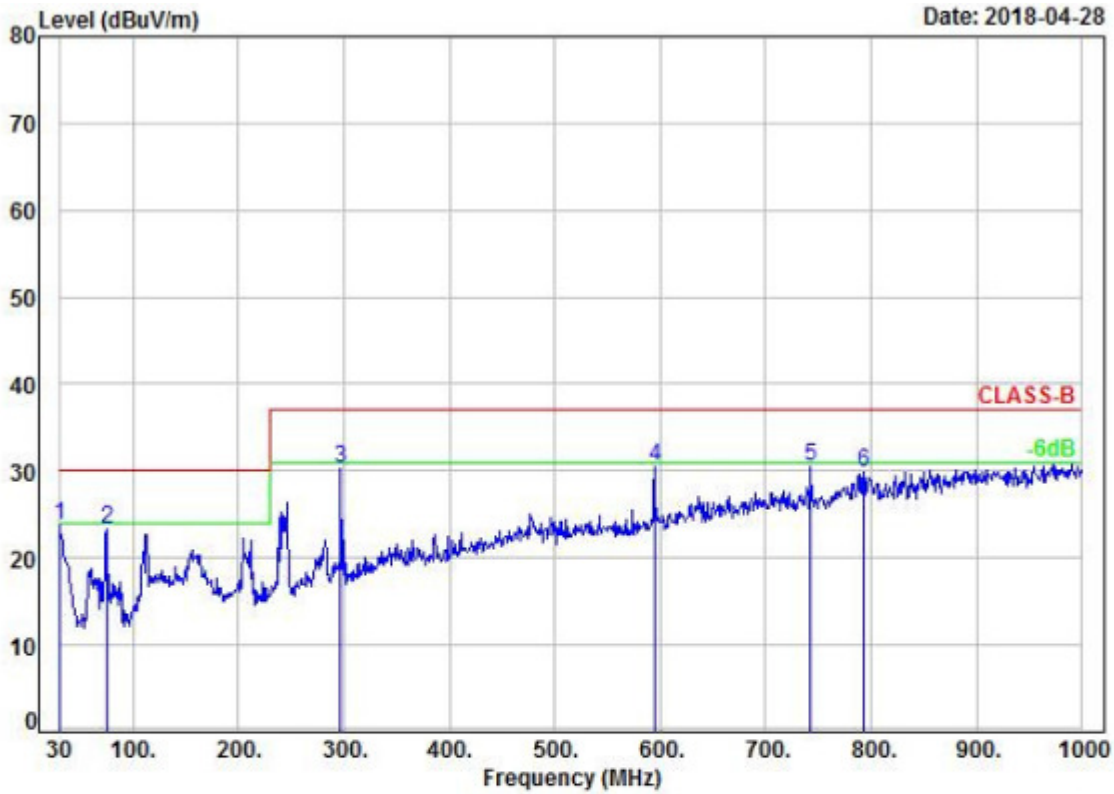

No.	Frequency (MHz)	Factor (dB/m)	Reading (dBUV)	Level (dBUV/m)	Limit (dBUV/m)	Margin (dB)	Detector	Height (cm)	Azimuth (deg)	P/F
1	30.00	-2.34	26.12	23.78	30.00	-6.22	Peak	400	0	P
2	74.62	-15.39	38.63	23.24	30.00	-6.76	Peak	400	0	P
3	296.75	-8.17	38.47	30.30	37.00	-6.70	Peak	400	0	P
4	594.54	-1.27	31.87	30.60	37.00	-6.40	Peak	400	0	P
5	742.95	1.69	28.80	30.49	37.00	-6.51	Peak	400	0	P
6	793.39	2.53	27.43	29.96	37.00	-7.04	Peak	400	0	P

Note: Level=Reading+Factor
Margin=Level-Limit
Factor=Antenna Factor + cable loss - Amplifier Factor

Test engineer: Tom



3.6. Test Result and Data (1GHz ~ 18GHz)

27V2Q

Power	: AC 120V	Pol/Phase	: VERTICAL
Test Mode	: Mode 1	Temperature	: 21 °C
Test Date	: Apr. 14, 2018	Humidity	: 41 %
Model No.	: 27V2Q	Atmospheric Pressure	: 1011 hPa

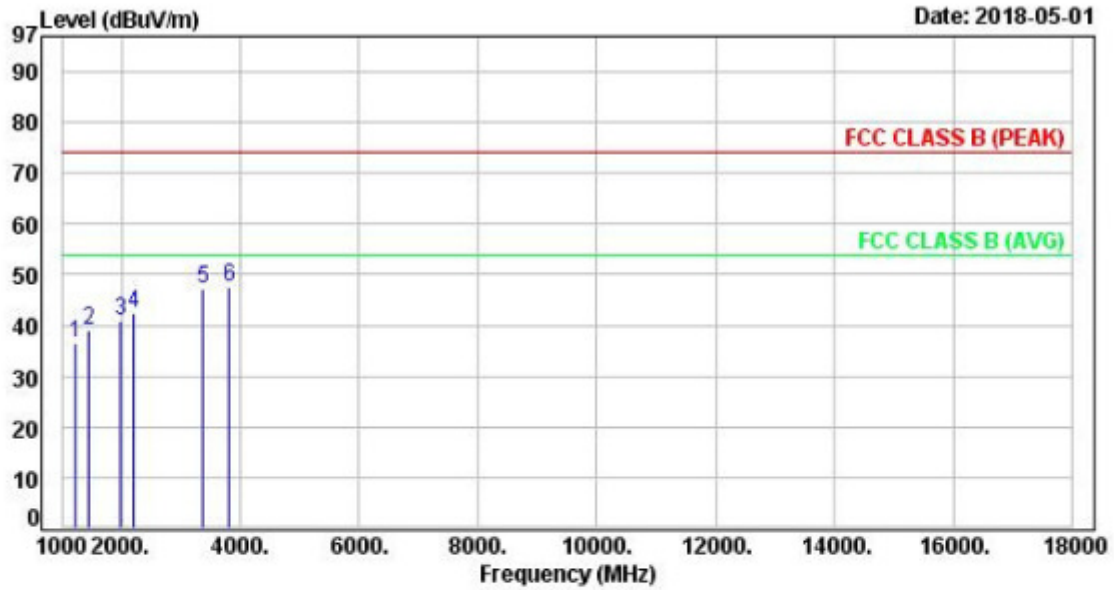

No.	Frequency (MHz)	Factor (dB/m)	Reading (dBuV)	Level (dBuV/m)	Limit (dBuV/m)	Margin (dB)	Detector	Height (cm)	Azimuth (deg)	P/F
1	1238.00	-7.77	44.41	36.64	74.00	-37.36	Peak	400	0	P
2	1459.00	-6.39	45.60	39.21	74.00	-34.79	Peak	400	0	P
3	1986.00	-2.47	43.43	40.96	74.00	-33.04	Peak	400	0	P
4	2207.00	-1.56	43.87	42.31	74.00	-31.69	Peak	400	0	P
5	3380.00	3.33	43.82	47.15	74.00	-26.85	Peak	400	0	P
6	3805.00	5.19	42.44	47.63	74.00	-26.37	Peak	400	0	P

Note: Level=Reading+Factor
Margin=Level-Limit
Factor=Antenna Factor + cable loss - Amplifier Factor



Power	: AC 120V	Pol/Phase	: HORIZONTAL
Test Mode	: Mode 1	Temperature	: 21 °C
Test Date	: Apr. 14, 2018	Humidity	: 41 %
Model No.	: 27V2Q	Atmospheric Pressure	: 1011 hPa

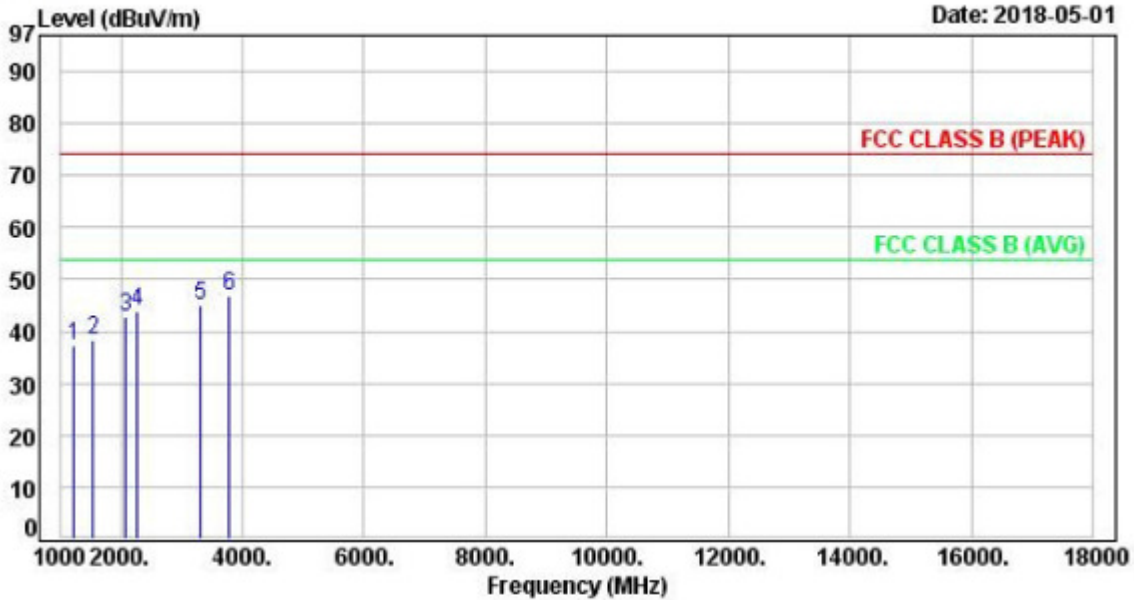

No.	Frequency (MHz)	Factor (dB/m)	Reading (dBuV)	Level (dBuV/m)	Limit (dBuV/m)	Margin (dB)	Detector	Height (cm)	Azimuth (deg)	P/F
1	1221.00	-7.89	45.25	37.36	74.00	-36.64	Peak	100	0	P
2	1544.00	-5.81	43.99	38.18	74.00	-35.82	Peak	100	0	P
3	2071.00	-2.09	44.75	42.66	74.00	-31.34	Peak	100	0	P
4	2258.00	-1.36	45.23	43.87	74.00	-30.13	Peak	100	0	P
5	3295.00	3.03	42.14	45.17	74.00	-28.83	Peak	100	0	P
6	3788.00	5.11	41.86	46.97	74.00	-27.03	Peak	100	0	P

Note: Level=Reading+Factor
Margin=Level-Limit
Factor=Antenna Factor + cable loss - Amplifier Factor



27V2H

Power	: AC 120V	Pol/Phase	: VERTICAL
Test Mode	: Mode 1	Temperature	: 21 °C
Test Date	: Apr. 14, 2018	Humidity	: 41 %
Model No.	: 27V2H	Atmospheric Pressure	: 1011 hPa

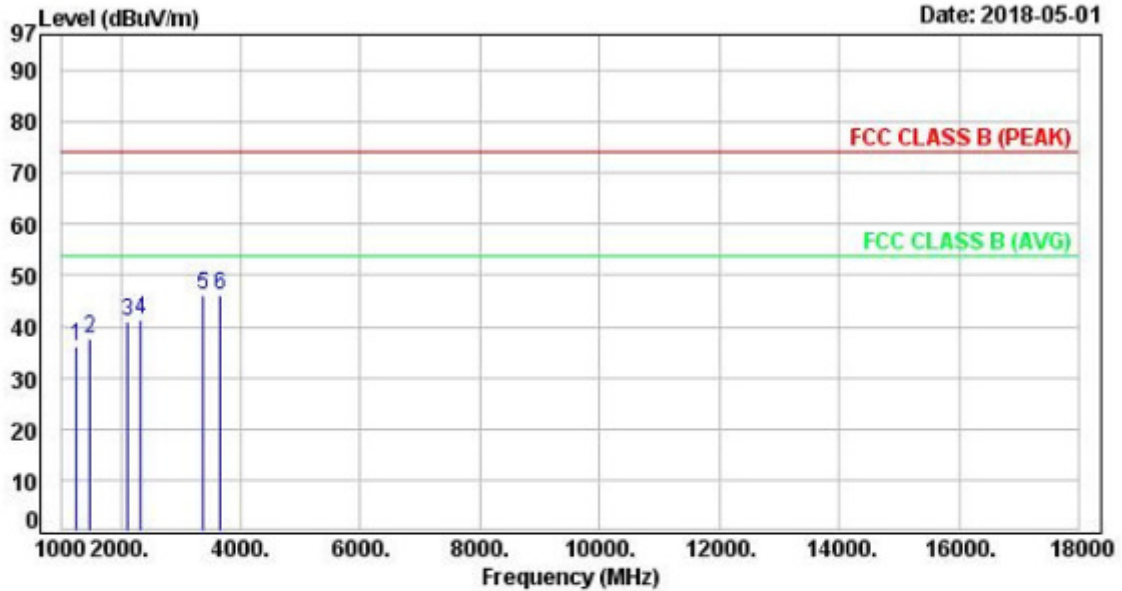

No.	Frequency (MHz)	Factor (dB/m)	Reading (dBuV)	Level (dBuV/m)	Limit (dBuV/m)	Margin (dB)	Detector	Height (cm)	Azimuth (deg)	P/F
1	1272.00	-7.56	43.68	36.12	74.00	-37.88	Peak	400	0	P
2	1476.00	-6.28	44.00	37.72	74.00	-36.28	Peak	400	0	P
3	2105.00	-1.96	42.75	40.79	74.00	-33.21	Peak	400	0	P
4	2343.00	-1.02	42.19	41.17	74.00	-32.83	Peak	400	0	P
5	3363.00	3.26	42.80	46.06	74.00	-27.94	Peak	400	0	P
6	3669.00	4.54	41.74	46.28	74.00	-27.72	Peak	400	0	P

Note: Level=Reading+factor
Margin=Level-Limit
Factor=Antenna Factor + cable loss - Amplifier Factor



Power	: AC 120V	Pol/Phase	: HORIZONTAL
Test Mode	: Mode 1	Temperature	: 21 °C
Test Date	: Apr. 14, 2018	Humidity	: 41 %
Model No.	: 27V2H	Atmospheric Pressure	: 1011 hPa

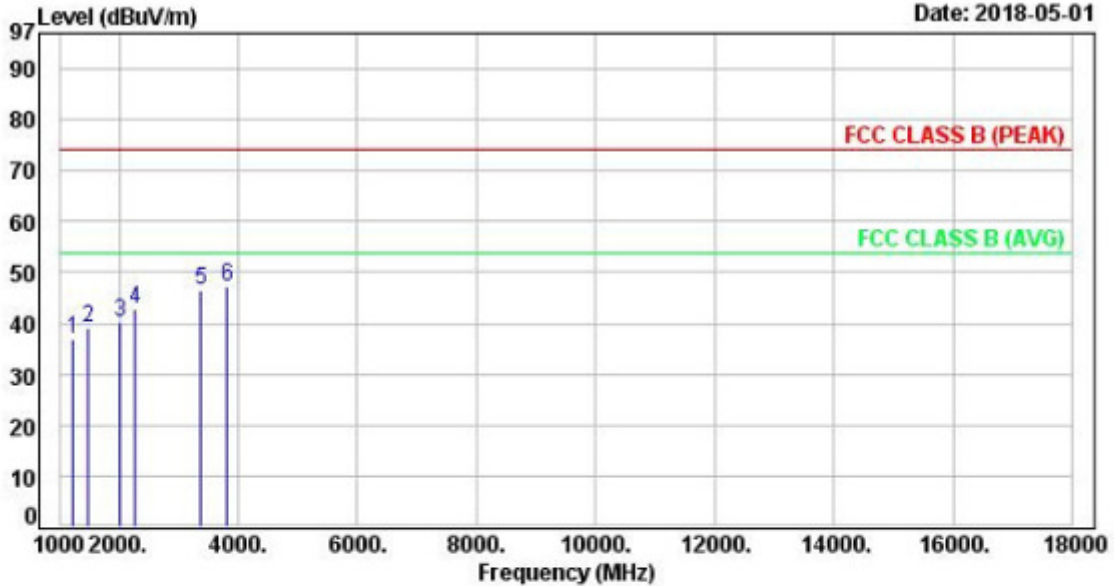

No.	Frequency (MHz)	Factor (dB/m)	Reading (dBuV)	Level (dBuV/m)	Limit (dBuV/m)	Margin (dB)	Detector	Height (cm)	Azimuth (deg)	P/F
1	1221.00	-7.89	44.91	37.02	74.00	-36.98	Peak	100	0	P
2	1493.00	-6.17	45.43	39.26	74.00	-34.74	Peak	100	0	P
3	2003.00	-2.35	42.56	40.21	74.00	-33.79	Peak	100	0	P
4	2258.00	-1.36	44.25	42.89	74.00	-31.11	Peak	100	0	P
5	3363.00	3.26	43.18	46.44	74.00	-27.56	Peak	100	0	P
6	3822.00	5.27	41.93	47.20	74.00	-26.80	Peak	100	0	P

Note: Level=Reading+Factor
Margin=Level-limit
Factor=Antenna Factor + cable loss - Amplifier Factor

Test engineer: Benson



3.7. Test Photographs (30MHz~1GHz)

27V2Q

Front View



Rear View





27V2H

Front View



Rear View





3.8. Test Photographs (1GHz~18GHz)

27V2Q

Front View



Rear View





27V2H

Front View



Rear View

