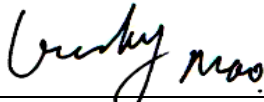
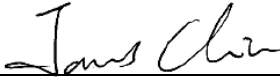

EMC Test Report

Project No. : 1605C263
Equipment : LCD Monitor
Model Name : (1)238LM00009, (2)AG241QG, (3)AG241QX
Applicant : TPV Electronics (Fujian) Co., Ltd.
Address : Rongqiao Economic and Technological Development
Zone, Fuqing City, Fujian Province, P.R. China

Date of Receipt : May 31, 2016
Date of Test : May 31, 2016 ~ Jun. 22, 2016
Issued Date : Jun. 23, 2016
Tested by : BTL Inc.

Testing Engineer : 
(Lucky Mao)

Technical Manager : 
(James Chiu)

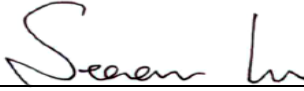
Authorized Signatory : 
(Steven Lu)

B T L I N C .

No.3, Jinshagang 1st Road, Shixia, Dalang Town,
Dongguan, Guangdong, China.

TEL: +86-769-8318-3000 FAX: +86-769-8319-6000



Declaration

BTL represents to the client that testing is done in accordance with standard procedures as applicable and that test instruments used has been calibrated with standards traceable to international standard(s) and/or national standard(s).

BTL's reports apply only to the specific samples tested under conditions. It is manufacture's responsibility to ensure that additional production units of this model are manufactured with the identical electrical and mechanical components. **BTL** shall have no liability for any declarations, inferences or generalizations drawn by the client or others from **BTL** issued reports.

BTL's report must not be used by the client to claim product certification, approval, or endorsement by NVLAP, NIST, or any agency of the Federal Government.

This report is the confidential property of the client. As a mutual protection to the clients, the public and **BTL-self**, extracts from the test report shall not be reproduced except in full with **BTL's** authorized written approval.

BTL's laboratory quality assurance procedures are in compliance with the **ISO Guide 17025** requirements, and accredited by the conformity assessment authorities listed in this test report.

Limitation

For the use of the authority's logo is limited unless the Test Standard(s)/Scope(s)/Item(s) mentioned in this test report is (are) included in the conformity assessment authorities acceptance respective.

Table of Contents	Page
REPORT ISSUED HISTORY	6
1 . CERTIFICATION	7
2 . SUMMARY OF TEST RESULTS	8
2.1 TEST FACILITY	10
2.2 MEASUREMENT UNCERTAINTY	10
3 . GENERAL INFORMATION	12
3.1 GENERAL DESCRIPTION OF EUT	12
3.2 DESCRIPTION OF TEST MODES	13
3.3 BLOCK DIAGRAM SHOWING THE CONFIGURATION OF SYSTEM TESTED	15
3.4 DESCRIPTION OF SUPPORT UNITS	18
4 . EMC EMISSION TEST- EN55032	20
4.1 RADIATED EMISSION	20
4.1.1 LIMITS	20
4.1.2 MEASUREMENT INSTRUMENTS LIST	22
4.1.3 TEST PROCEDURE	23
4.1.4 DEVIATION FROM TEST STANDARD	23
4.1.5 TEST SETUP	23
4.1.6 MEASUREMENT DISTANCE	25
4.1.7 TEST RESULTS (UP TO 1 GHZ)	26
4.1.8 TEST RESULTS (ABOVE 1 GHZ)	46
4.2 CONDUCTED EMISSION MEASUREMENT AT AC MAINS POWER PORTS	66
4.2.1 LIMITS	66
4.2.2 MEASUREMENT INSTRUMENTS LIST	66
4.2.3 TEST PROCEDURE	67
4.2.4 DEVIATION FROM TEST STANDARD	67
4.2.5 TEST SETUP	67
4.2.6 TEST RESULTS	68
4.3 HARMONIC CURRENT EMISSIONS TEST	84
4.3.1 LIMITS	84
4.3.2 MEASUREMENT INSTRUMENTS LIST	84
4.3.3 TEST PROCEDURE	85
4.3.4 DEVIATION FROM TEST STANDARD	85
4.3.5 TEST SETUP	85
4.3.6 EUT OPERATING CONDITIONS	85
4.3.7 TEST RESULTS	86
4.4 VOLTAGE CHANGES, VOLTAGE FLUCTUATIONS AND FLICKER TEST	92
4.4.1 LIMITS	92
4.4.2 MEASUREMENT INSTRUMENTS LIST	92

Table of Contents	Page
4.4.3 TEST PROCEDURE	92
4.4.4 DEVIATION FROM TEST STANDARD	92
4.4.5 TESTSETUP	93
4.4.6 EUT OPERATING CONDITIONS	93
4.4.7 TEST RESULTS	94
5 . EMC IMMUNITY TEST	96
5.1 STANDARD COMPLIANCE/SERVIRITY LEVEL/CRITERIA	96
5.2 GENERAL PERFORMANCE CRITERIA	97
5.3 GENERAL PERFORMANCE CRITERIA TEST SETUP	97
5.4 ELECTROSTATIC DISCHARGE IMMUNITY TEST (ESD)	98
5.4.1 TEST SPECIFICATION	98
5.4.2 MEASUREMENT INSTRUMENTS	98
5.4.3 TEST PROCEDURE	98
5.4.4 DEVIATION FROM TEST STANDARD	99
5.4.5 TEST SETUP	99
5.4.6 TEST RESULTS	100
5.5 RADIATED, RADIO-FREQUENCY, ELECTROMAGNETIC FIELD IMMUNITY TEST (RS)	110
5.5.1 TEST SPECIFICATION	110
5.5.2 MEASUREMENT INSTRUMENTS	110
5.5.3 TEST PROCEDURE	110
5.5.4 DEVIATION FROM TEST STANDARD	110
5.5.5 TEST SETUP	111
5.5.6 TEST RESULTS	112
5.6 ELECTRICAL FAST TRANSIENT/BURST IMMUNITY TEST (EFT/BURST)	113
5.6.1 TEST SPECIFICATION	113
5.6.2 MEASUREMENT INSTRUMENTS	113
5.6.3 TEST PROCEDURE	113
5.6.4 DEVIATION FROM TEST STANDARD	113
5.6.5 TEST SETUP	114
5.6.6 TEST RESULTS	115
5.7 SURGE IMMUNITY TEST	117
5.7.1 TEST SPECIFICATION	117
5.7.2 MEASUREMENT INSTRUMENTS	117
5.7.3 TEST PROCEDURE	118
5.7.4 DEVIATION FROM TEST STANDARD	118
5.7.5 TEST SETUP	118
5.7.6 TEST RESULTS	119
5.8 IMMUNITY TO CONDUCTED DISTURBANCES, INDUCED BY RADIO-FREQUENCY FIELDS TEST (CS)	121
5.8.1 TEST SPECIFICATION	121

Table of Contents	Page
5.8.2 MEASUREMENT INSTRUMENTS	121
5.8.3 TEST PROCEDURE	121
5.8.4 DEVIATION FROM TEST STANDARD	121
5.8.5 TEST SETUP	122
5.8.6 TEST RESULTS	123
5.9 POWER FREQUENCY MAGNETIC FIELD IMMUNITY TEST (PFMF)	125
5.9.1 TEST SPECIFICATION	125
5.9.2 MEASUREMENT INSTRUMENTS	125
5.9.3 TEST PROCEDURE	125
5.9.4 DEVIATION FROM TEST STANDARD	125
5.9.5 TEST SETUP	126
5.9.6 TEST RESULTS	127
5.10 VOLTAGE DIPS, SHORT INTERRUPTIONS AND VOLTAGE VARIATIONS	
IMMUNITY TEST	128
5.10.1 TEST SPECIFICATION	128
5.10.2 MEASUREMENT INSTRUMENTS	128
5.10.3 TEST PROCEDURE	128
5.10.4 DEVIATION FROM TEST STANDARD	128
5.10.5 TEST SETUP	129
5.10.6 TEST RESULTS	130
6 . EUT TEST PHOTO	132

REPORT ISSUED HISTORY

Issued No.	Description	Issued Date
BTL-EMC-1-1605C263	Original issue.	Jun. 23, 2016

1. CERTIFICATION

- Equipment : LCD Monitor
Brand Name : AOC
Model Name : (1)238LM00009, (2)AG241QG, (3)AG241QX
Applicant : TPV Electronics (Fujian) Co., Ltd.
Factory : 1. TPV Electronics (Fujian) Co., Ltd.
2. L&T Display Technology (Fujian) Ltd
3. TPV Display Technology (China) Co., Ltd
4. TPV Display Technology (Wuhan) Co., Ltd
5. TPV Display Technology (Beihai) Co.,Ltd.
6. TPV Technology(Qingdao) Co.,Ltd.
7. Envision Industry of Electronic Products Ltd
8. Hefei Huntkey Display Technology Co.,Ltd.
9. TREND SMART CE MEXICO S. DE R.L. DE C.V.
10. TPV Electronics (Fujian) Co., Ltd.
- Address : 1. Shangzheng, Yuan Hong Road, Fuqing City, Fujian Province, P.R.China
2. Optoelectronic Park, Rongqiao Economic and Technological Development Zone, Fuqing City, Fujian Province, PRC
3. No.106 Jinghai 3 Rd., BDA, Beijing City 100176 P.R. China
4. Unique No.11 Zhuankou Development District of Economic Technological Development Zone Wuhan City, P.R.China
5. China Electronic Beihai Industry Park, Northeast of the Crossing between Taiwan Road and Jilin Road, Beihai City, Guangxi, P.R.China
6. NO.99 Huoju Road, High-tech Industrial Development Zone, Qingdao City, Shandong Province, China (PRC)
7. Rodovia Anhanguera S/N - KM 49 Tijuco Preto - Jundiá - SP - Brazil
8. South Jinxiu Road, East Qingtan Road, Economic And Technological Development Zone, Hefei
9. Avenida Sor Juana Ines de la Cruz No. 19602 Parque Industrial la Frontera Fracc. Nueva Tijuana (Otay) Tijuana, B.C. CP.22500
10. Rongqiao Economic and Technological Development Zone, Fuqing City, Fujian Province, P.R.China
- Date of Test : May 31, 2016 ~ Jun. 22, 2016
Test Sample : Engineering Sample
Standard(s) : EN 55032: 2012+AC:2013 / CISPR 32: 2012 Class B
AS/NZS CISPR 32: 2013
EN 61000-3-2: 2014 Class D
EN 61000-3-3: 2013
EN 55024: 2010
EN 61000-4-2: 2009
EN 61000-4-3: 2006+A1: 2008+A2: 2010
EN 61000-4-4: 2012
EN 61000-4-5: 2014
EN 61000-4-6: 2014
EN 61000-4-8: 2010
EN 61000-4-11: 2004

The above equipment has been tested and found compliance with the requirement of the relative standards by BTL Inc.

The test data, data evaluation, and equipment configuration contained in our test report (Ref No. BTL-EMC-1-1605C263) were obtained utilizing the test procedures, test instruments, test sites that has been accredited by the Authority of TAF according to the ISO-17025 quality assessment standard and technical standard(s).

2. SUMMARY OF TEST RESULTS

Test procedures according to the technical standards:

Emission					
Standard(s)	Test Item	Limit	Judgment	Remark	
EN 55032: 2012+AC:2013 CISPR 32: 2012 AS/NZS CISPR 32: 2013	Radiated emissions up to 1 GHz	Class B	PASS		
	Radiated emissions above 1 GHz	Class B	PASS	NOTE (2)	
	Radiated emissions from FM receivers	-----	N/A	NOTE (1) NOTE (6)	
	Conducted emissions AC mains power port	Class B	PASS	NOTE (7)	
	Asymmetric mode conducted emissions	AAN	-----	N/A	NOTE (1) NOTE (8)
		Current Probe	-----	N/A	
		CVP	-----	N/A	
Conducted differential voltage emissions	-----	N/A	NOTE (1) NOTE (9)		

Standard(s)	Test Item	Limit	Judgment	Remark
EN 61000-3-2: 2014	Harmonic current emissions	Class D	PASS	NOTE (3)
EN 61000-3-3: 2013	Voltage changes, voltage fluctuations and flicker	-----	PASS	

Immunity EN 55024: 2010				
Section	Test Item	Criterion	Judgment	Remark
EN 61000-4-2: 2009	Electrostatic discharge immunity	B	PASS	
EN 61000-4-3: 2006+A1: 2008+A2: 2010	Radiated, radio-frequency, electromagnetic field immunity	A	PASS	
EN 61000-4-4: 2012	Electrical fast transient/burst immunity	B	PASS	
EN 61000-4-5: 2014	Surge immunity	B/C	PASS	NOTE (4)
EN 61000-4-6: 2014	Immunity to conducted disturbances, induced by radio-frequency fields	A	PASS	
EN 61000-4-8: 2010	Power frequency magnetic field immunity	A	PASS	
EN 61000-4-11: 2004	Voltage dips, short interruptions and voltage variations immunity	B / C / C	PASS	NOTE (5)

NOTE:

- (1) "N/A" denotes test is not applicable to this device.
- (2) The EUT's max operating frequency is 340MHz which exceeds 108 MHz, so the test will be performed.
- (3) The power consumption of EUT is less than 75W and no Limits apply.
- (4) Performance Criterion **C** for signal ports and telecommunication ports.
Performance Criterion **B** for input d.c. power port and a.c. power ports.
- (5) Voltage Dips: >95% reduction – Performance Criterion **B**
Voltage Dips: 30% reduction – Performance Criterion **C**
Voltage Interruptions: >95% reduction – Performance Criterion **C**
- (6) If the EUT has FM function the test will be performed.
- (7) If the EUT has AC power mains port the test will be performed.

(8)

Cable Type	Number of pairs	Measurement type	Procedures
Balanced Unscreened	1 (2 wire) ;2 (4 wire); 3 (6 wire) ;4 (8 wire)	Voltage	AAN
Balanced Unscreened	See a)	Voltage and Current	CP+CVP
Screened or Coaxial	n/a	Voltage	AAN
Screened or Coaxial	n/a	Voltage or Current	CP or CVP
Unbalanced cables	n/a	Voltage and Current	CP+CVP

Ports connected to cables with more than 4 balanced pairs or where the port is unable to function correctly when connected through an AAN.

- (9) If the EUT has tuner port the test will be performed.
- (10) The requirement followed by the client's specification.

2.1 TEST FACILITY

The test facilities used to collect the test data in this report is located at the location of No.3, Jinshagang 1st Road, Shixia, Dalang Town, Dongguan, Guangdong, China.

2.2 MEASUREMENT UNCERTAINTY

Where relevant, the following measurement uncertainty levels have been estimated for tests performed on the EUT as specified in CISPR 16-4-2.

The BTL measurement uncertainty is less than the CISPR 16-4-2 U_{CISPR} requirement.

The reported uncertainty of measurement $y \pm U$, where expanded uncertainty U is based on a standard uncertainty multiplied by a coverage factor of $k=2$, providing a level of confidence of approximately **95%**.

A. Conducted Emissions AC Mains Power Port Measurement:

Test Site	Method	Measurement Frequency Range	U,(dB)
DG-C01	CISPR	150 kHz ~ 30MHz	3.16

B. Radiated Measurement :

Test Site	Method	Measurement Frequency Range	Ant. H / V	U,(dB)
DG-CB08 (10m)	CISPR	30MHz ~ 200MHz	V	4.66
		30MHz ~ 200MHz	H	4.64
		200MHz ~ 1,000MHz	V	4.88
		200MHz ~ 1,000MHz	H	4.86

Test Site	Method	Measurement Frequency Range	U,(dB)
DG-CB08 (3m)	CISPR	1 ~ 6 GHz	4.26
		6 ~18 GHz	5.30

C, Harmonic/ Flicker Measurement:

Test Site	Method	Test Item	U(%)
C01	EN 61000-3-2	Voltage	0.774
	EN 61000-3-3	Current	0.782

D. Immunity Measurement :

Test Site	Method	Test Item	U
SR02	EN 61000-4-2	Voltage (2kV/4kV/6kV/8kV/15kV/25kV/30kV)	1.0%
		Peak Current	6.0%
		30/60ns Current	6.0%
		Rise time	6.4%
CB05	EN 61000-4-3	80MHz~1GHz	2.175 dB
SR05	EN 61000-4-4	Impulse Voltage	4.0 %
		Impulse Rise Time	4.5 %
		Impulse duration Time	4.0 %
SR05	EN 61000-4-5	Impulse Voltage	4.0 %
		Impulse Rise Time	4.5 %
		Impulse duration Time	4.0 %
CB06	EN 61000-4-6	CDN: 150kHz~230MHz	2.509 dB
		EM Clamp: 150kHz~230MHz	3.094 dB
SR05	EN 61000-4-8	Magnetic Field Level	3 %
SR05	EN 61000-4-11	Impulse Amplitude	4 %
		Timing	3 %

Note: Unless specifically mentioned, the uncertainty of measurement has not been taken into account to declare the compliance or non-compliance to the specification.

3. GENERAL INFORMATION

3.1 GENERAL DESCRIPTION OF EUT

Equipment	LCD Monitor
Trade Name	AOC
Model Name	(1)238LM00009, (2)AG241QG, (3)AG241QX
Model Difference	Model AG241QG and AG241QX only mainboard are different.
Power Source	DC Voltage supplied from AC/DC adapter. Brand / Model: TPV / ADPC2065
Power Rating	I/P: 100-240V~ 1.5A 50-60Hz O/P:20V---3.25A

Cable Type	Shielded Type	Ferrite Core	Length(m)	Note
D-SUB	Shielded	YES	1.5/1.8	Bonded two Ferrite Cores
DVI	Shielded	YES	1.2/1.5/1.8	Bonded two Ferrite Cores
HDMI	Shielded	NO	1.2/1.5/1.8	
Display	Shielded	NO	1.2/1.5/1.8	
Audio	Shielded	NO	1.2/1.5/1.8	
USB	Shielded	NO	1.2/1.5/1.8	
AC Power Cord	Non-shielded	NO	1.2/1.5/1.8	1.8m is worst case Detachable (3 Pin)

Note:

1. For a more detailed features description, please refer to the manufacturer's specifications or the user's manual.
2. Power cable 1.8m, 1.5m and 1.2m length, worst case is Power cable 1.8m with Display+HDMI+Audio+USB or D-SUB+DVI+HDMI+Display+Audio+USB 1.8m, 1.5m and 1.2m length testing and recording in test report.

3.2 DESCRIPTION OF TEST MODES

To investigate the maximum EMI emission characteristics generates from EUT, the test system was pre-scanning tested base on the consideration of following EUT operation mode or test configuration mode which possible have effect on EMI emission level. Each of these EUT operation mode(s) or test configuration mode(s) mentioned above was evaluated respectively.

Pretest Mode	Description
Mode 1	D-SUB 1980*1080 60Hz (715G8055)
Mode 2	D-SUB 1280*1024 75Hz (715G8055)
Mode 3	D-SUB 640*480 60Hz (715G8055)
Mode 4	DVI 2560*1440 144Hz (715G8055)
Mode 5	DVI 1920*1080 60Hz (715G8055)
Mode 6	DVI 640*480 60Hz (715G8055)
Mode 7	Display 2560*1440 144Hz (715G8055) (715G8083)
Mode 8	Display 1920*1080 60Hz (715G8055) (715G8083)
Mode 9	Display 640*480 60Hz (715G8055) (715G8083)
Mode 10	HDMI 2560*1440 60Hz (715G8083)
Mode 11	HDMI 1920*1080 60Hz (715G8083)
Mode 12	HDMI 640*480 60Hz (715G8083)
Mode 13	HDMI 1 2560*1440 144Hz (715G8055)
Mode 14	HDMI 1 1920*1080 60Hz (715G8055)
Mode 15	HDMI 1 640*480 60Hz (715G8055)
Mode 16	HDMI 2 2560*1440 144Hz (715G8055)
Mode 17	HDMI 2 1920*1080 60Hz (715G8055)
Mode 18	HDMI 2 640*480 60Hz (715G8055)
Mode 19	HDMI 1080P (715G8083)
Mode 20	HDMI 576P (715G8083)
Mode 21	HDMI 480i (715G8083)
Mode 21	HDMI 1 1080P (715G8055)
Mode 22	HDMI 1 576P (715G8055)
Mode 23	HDMI 1 480i (715G8055)
Mode 24	HDMI 2 1080P (715G8055)
Mode 25	HDMI 2 576P (715G8055)
Mode 26	HDMI 2 480i (715G8055)
Mode 27	MHL 1080P (715G8055)

Conducted emission test	
Final Test Mode	Description
Mode 7	Display 2560*1440 144Hz (715G8055) (715G8083)
Mode 10	HDMI 2560*1440 60Hz (715G8083)
Mode 16	HDMI 2 2560*1440 144Hz (715G8055)
Mode 19	HDMI 1080P (715G8083)
Mode 24	HDMI 2 1080P (715G8055)

Radiated emission test	
Final Test Mode	Description
Mode 7	Display 2560*1440 144Hz (715G8055) (715G8083)
Mode 10	HDMI 2560*1440 60Hz (715G8083)
Mode 16	HDMI 2 2560*1440 144Hz (715G8055)
Mode 19	HDMI 1080P (715G8083)
Mode 24	HDMI 2 1080P (715G8055)

Harmonic current emissions & Voltage changes, voltage fluctuations and flicker test	
Final Test Mode	Description
Mode 10	HDMI 2560*1440 60Hz (715G8083)
Mode 16	HDMI 2 2560*1440 144Hz (715G8055)

Immunity tests	
Final Test Mode	Description
Mode 10	HDMI 2560*1440 60Hz (715G8083)
Mode 16	HDMI 2 2560*1440 144Hz (715G8055)

3.3 BLOCK DIAGRAM SHOWING THE CONFIGURATION OF SYSTEM TESTED

PC Mode (715G8083)

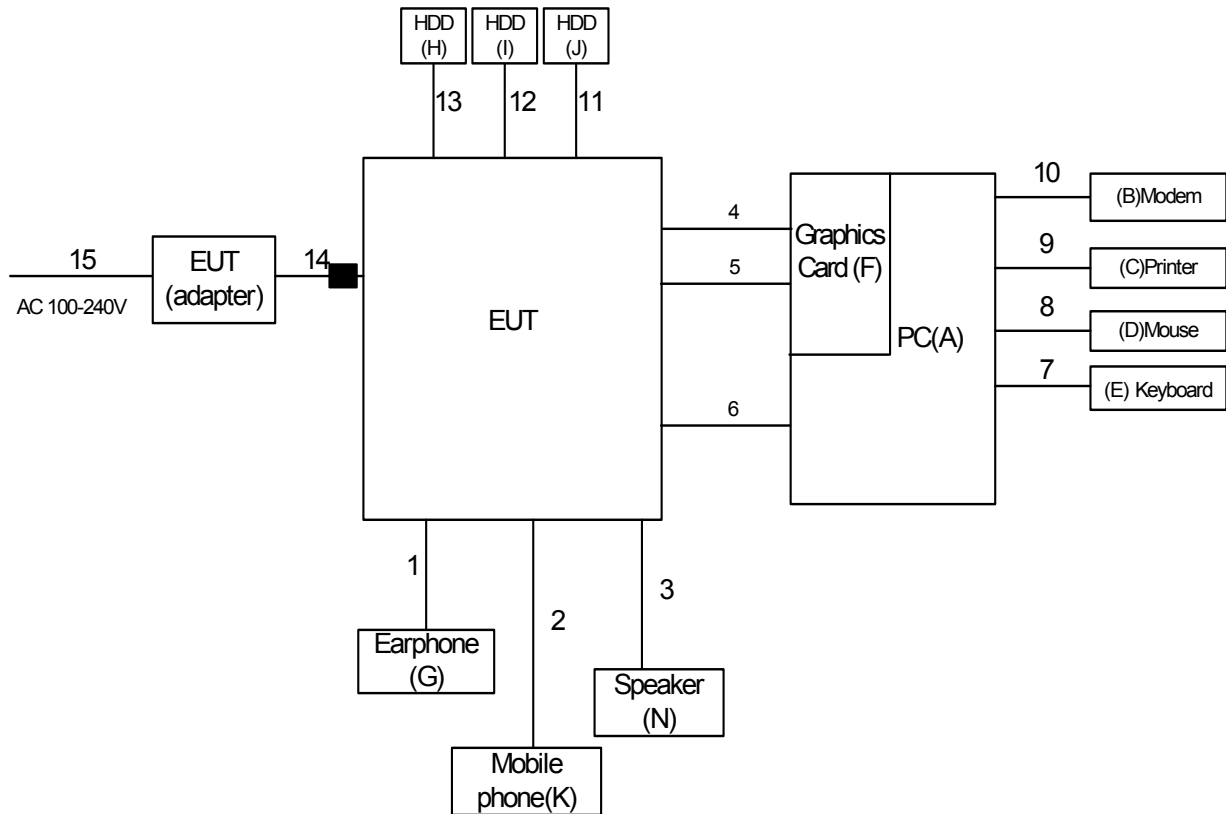

■ Ferrite core

DVD Mode (715G8083)

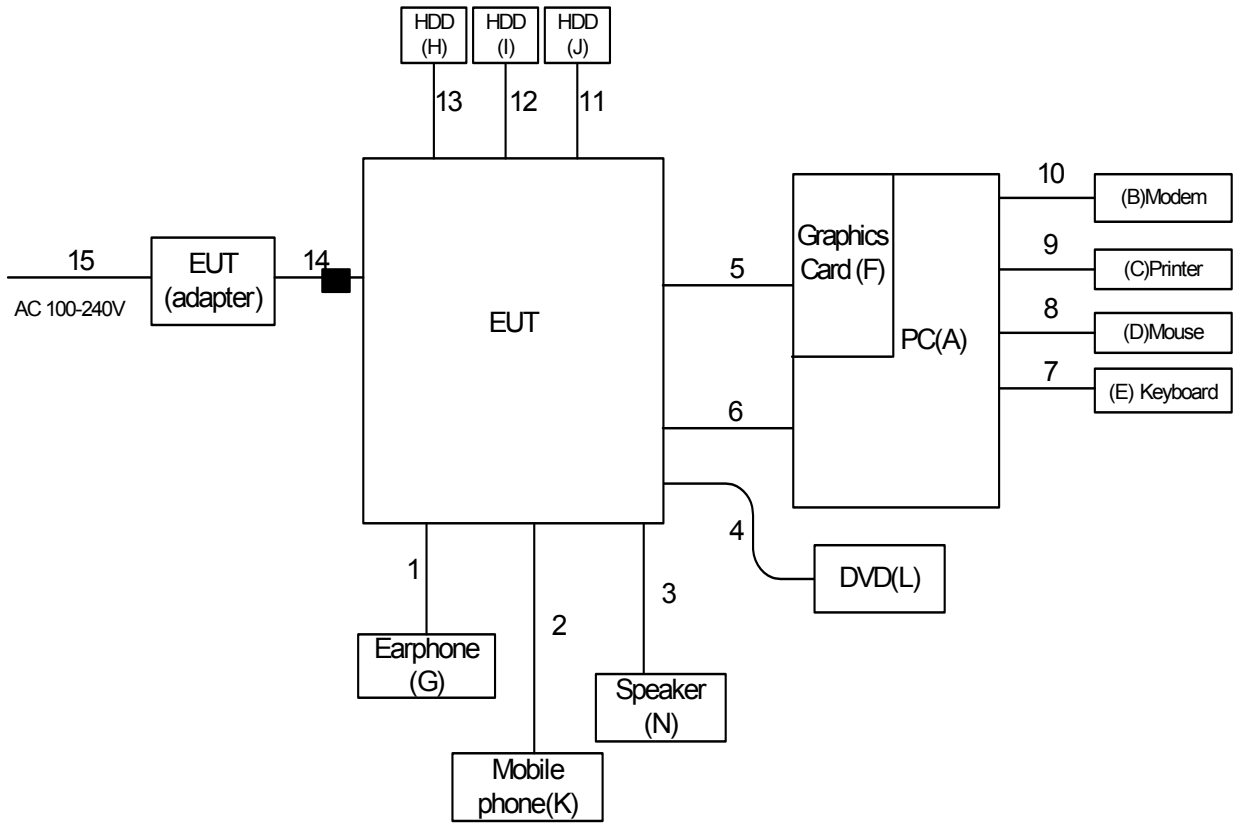

■ Ferrite core

PC & DVD Mode (715G8055)

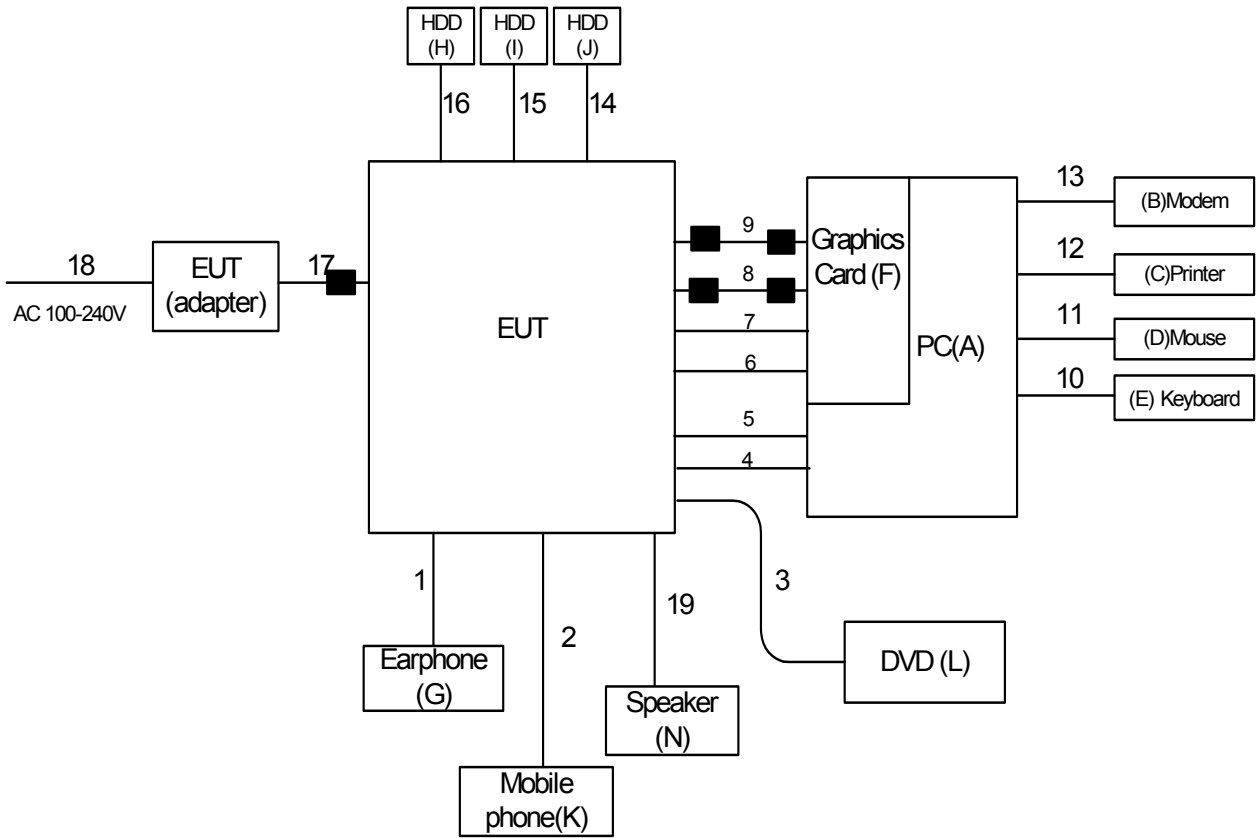

■ Ferrite core

3.4 DESCRIPTION OF SUPPORT UNITS

The EUT has been tested as an independent unit together with other necessary accessories or support units. The following support units or accessories were used to form a representative test configuration during the tests.

Item	Equipment	Mfr/Brand	Model/Type No.	FCC ID	Series No.
A	PC	DELL	VOSTRO 470	DOC	24454162837
B	Modem	ACEEX	DM-1414V	IFAXDM1414	0603002131
C	Printer	SII	DPU-414	DOC	3018507 B
D	USB Mouse	DELL	MO28UOL	DOC	23-122591
E	USB Keyboard	DELL	SK-8815(L)	DOC	00975811
F	Graphics card	MSI	GF 9500GT	DOC	602-V133-22SB08081 70967
G	Earphone	PHILIPS	SHMI500	VER	N/A
H	HDD	WD	WDBBLW5000A AL	DOC	WX31AA323251
I	HDD	WD	WDBBLW5000A AL	DOC	WX81A64A5EJ5
J	HDD	WD	WDBBLW5000A AL	DOC	WX31A93J5223
K	mobile phone	samsung	SGH-1747	A3LSGH1747	R31C208VLDB
L	DVD	Pioneer	BDP-3110-K	VER	LJTL009045CN
N	Speaker	Behringer Holdings	MS20	NA	S1105384274

For mainboard (715G8083)

Item	Shielded Type	Ferrite Core	Length	Note
1	NO	NO	1.8m	Earphone Cable
2	YES	NO	1m	USB Cable
3	NO	NO	1.8m	Audio Cable
4	YES	NO	1.2/1.5/1.8m	HDMI Cable
5	YES	NO	1.2/1.5/1.8m	Display Cable
6	YES	NO	1.2/1.5/1.8m	USB Cable
7	YES	NO	1.5m	USB Cable
8	YES	NO	1.5m	USB Cable
9	YES	NO	1.5m	Parallel Cable
10	YES	NO	1.5m	RS232 Cable
11	YES	NO	1m	USB Cable
12	YES	NO	1m	USB Cable
13	YES	NO	1m	USB Cable
14	NO	YES	1.2m	DC Cable
15	NO	NO	1.2/1.5/1.8m	AC Cable

For mainboard (715G8055)

Item	Shielded Type	Ferrite Core	Length	Note
1	NO	NO	1.8m	Earphone Cable
2	YES	NO	1m	USB Cable
3	YES	NO	1.2/1.5/1.8m	HDMI Cable
4	YES	NO	1.2/1.5/1.8m	USB Cable
5	NO	NO	1.2/1.5/1.8m	Audio Cable
6	YES	NO	1.2/1.5/1.8m	Display Cable
7	YES	NO	1.2/1.5/1.8m	HDMI Cable
8	YES	YES	1.8/1.5m	D-SUB Cable
9	YES	YES	1.2/1.5/1.8m	DVI Cable
10	YES	NO	1.5m	USB Cable
11	YES	NO	1.5m	USB Cable
12	YES	NO	1.5m	Parallel Cable
13	YES	NO	1.5m	RS232 Cable
14	YES	NO	1m	USB Cable
15	YES	NO	1m	USB Cable
16	YES	NO	1m	USB Cable
17	NO	YES	1.2m	DC Cable
18	NO	NO	1.2/1.5/1.8m	AC Cable
19	NO	NO	1.8m	Audio Cable

Note:

(1) The support equipment was authorized by declaration of conformity (DOC).

4. EMC EMISSION TEST- EN55032

4.1 RADIATED EMISSION

4.1.1 LIMITS

Class A equipment up to 1000MHz

Table clause	Frequency MHz	Measurement		Class A limit dB(uV/m)
		Distance m	Detector type/bandwidth	OATS/SAC
A2.1	30-230	10	Quasi peak / 120 kHz	40
	230-1000			47
A2.2	30-230	3		50
	230-1000			57

Class A equipment above 1000MHz

Table clause	Frequency MHz	Measurement		Class A limit dB(uV/m)
		Distance m	Detector type/bandwidth	FSOATS
A3.1	1000-3000	3	Average / 1 MHz	56
	3000-6000			60
A3.2	1000-3000		Peak / 1 MHz	76
	3000-6000			80

Class B equipment up to 1000MHz

Table clause	Frequency MHz	Measurement		Class B limit dB(uV/m)
		Distance m	Detector type/bandwidth	OATS/SAC
A4.1	30-230	10	Quasi peak / 120 kHz	30
	230-1000			37
A4.2	30-230	3		40
	230-1000			47

Class B equipment above 1000MHz

Table clause	Frequency MHz	Measurement		Class B limit dB(uV/m)
		Distance m	Detector type/bandwidth	FSOATS
A5.1	1000-3000	3	Average / 1 MHz	50
	3000-6000			54
A5.2	1000-3000		Peak / 1 MHz	70
	3000-6000			74

Notes:

- (1) The limit for radiated test was performed according to as following: EN 55032
- (2) The tighter limit applies at the band edges.
- (3) Emission level (dBuV/m)=20log Emission level (uV/m).
- (4) The test result calculated as following:
 Measurement Value = Reading Level + Correct Factor
 Correct Factor = Antenna Factor + Cable Loss - Amplifier Gain(if use)
 Margin Level = Measurement Value - Limit Value

Required highest frequency for radiated measurement

Highest internal frequency (F_x) MHz	Highest measured frequency MHz
$F_x \leq 108$	1000
$108 < F_x \leq 500$	2000
$500 < F_x \leq 1000$	5000
$F_x > 1000$	5 th up to a maximum 6 GHz,

Note for FM and TV broadcast receiver, F_x is determined from the highest frequency generated or used excluding the local oscillator and tuned frequencies.

4.1.2 MEASUREMENT INSTRUMENTS LIST

Item	Kind of Equipment	Manufacturer	Type No.	Serial No.	Calibrated until
1	Antenna	EMCO	3142C	00066462	Mar. 27, 2017
2	Antenna	EMCO	3142C	00066464	Mar. 27, 2017
3	Amplifier	Agilent	8447D	2944A11203	Oct. 11, 2016
4	Amplifier	Agilent	8447D	2944A11204	Oct. 11, 2016
5	Spectrum Analyzer	Agilent	E4443A	MY48250370	Oct. 11, 2016
6	RF Pre-selector	Agilent	N9039A	MY46520201	Oct. 11, 2016
7	Test Cable	emci	LMR-400 (30MHz-1GHz)	C-23	Dec. 31, 2016
8	Test Cable	emci	LMR-400 (30MHz-1GHz)	C-22	Dec. 31, 2016
9	Receiver	Agilent	N9038A	MY53220133	Jun. 23, 2017
10	Multi-Device Controller	ETS-Lindgren	2090	N/A	N/A
11	Measurement Software	Farad	EZ-EMC Ver.BTL-2ANT-1	N/A	N/A
12	Horn Antenna	EMCO	3115	9605-4803	Mar. 27, 2017
13	Amplifier	Agilent	8449B	3008A02584	Oct. 11, 2016
14	Test Cable	emci	SUCOFLEX_15m_5m(0.01GHz-26.5GHz)	C-15/C-39	Jun. 03, 2017
15	Position Control	MF	MF-7802	MF78020815 9	N/A
16	Test Cable	emci	SUCOFLEX 102_8m(0.01GHz-40G Hz)	C-38	Mar. 27, 2017

Remark: "N/A" denotes no model name, no serial no. or no calibration specified.
All calibration period of equipment list is one year.

4.1.3 TEST PROCEDURE

- a. PC MODE: The measuring distance of 10 m shall be used for measurements. The EUT was placed on the top of a rotating table 0.8 meter above the ground at a 10 meter semi-anechoic chamber. The table was rotated 360 degrees to determine the position of the highest radiation.(below 1GHz).
- DVD MODE: The measuring distance of 3 m shall be used for measurements. The EUT was placed on the top of a rotating table 0.8 meter above the ground at a 10 meter semi-anechoic chamber. The table was rotated 360 degrees to determine the position of the highest radiation.(below 1GHz)
- b. The measuring distance of 3 m shall be used for measurements. The EUT was placed on the top of a rotating table 0.8 meter above the ground at a 10 meter semi-anechoic chamber. The table was rotated 360 degrees to determine the position of the highest radiation.(above 1GHz)
- c. The height of the equipment or of the substitution antenna shall be 0.8 m, the height of the test antenna shall vary between 1 m to 4 m. Both horizontal and vertical polarizations of the antenna are set to make the measurement.
- d. The initial step in collecting radiated emission data is a receiver peak detector mode pre-scanning the measurement frequency range. Significant peaks are then marked and then Quasi Peak detector mode re-measured.
- e. All readings are Peak unless otherwise stated QP in column of Note. Peak denotes that the Peak reading compliance with the QP Limits and then QP Mode measurement didn't perform. (below 1GHz)
- f. All readings are Peak Mode value unless otherwise stated AVG in column of Note. If the Peak Mode Measured value compliance with the Peak Limits and lower than AVG Limits, the EUT shall be deemed to meet both Peak & AVG Limits and then only Peak Mode was measured, but AVG Mode didn't perform. (above 1GHz)
- g. For the actual test configuration, please refer to the related Item - EUT Test Photos.

4.1.4 DEVIATION FROM TEST STANDARD

No deviation

4.1.5 TEST SETUP

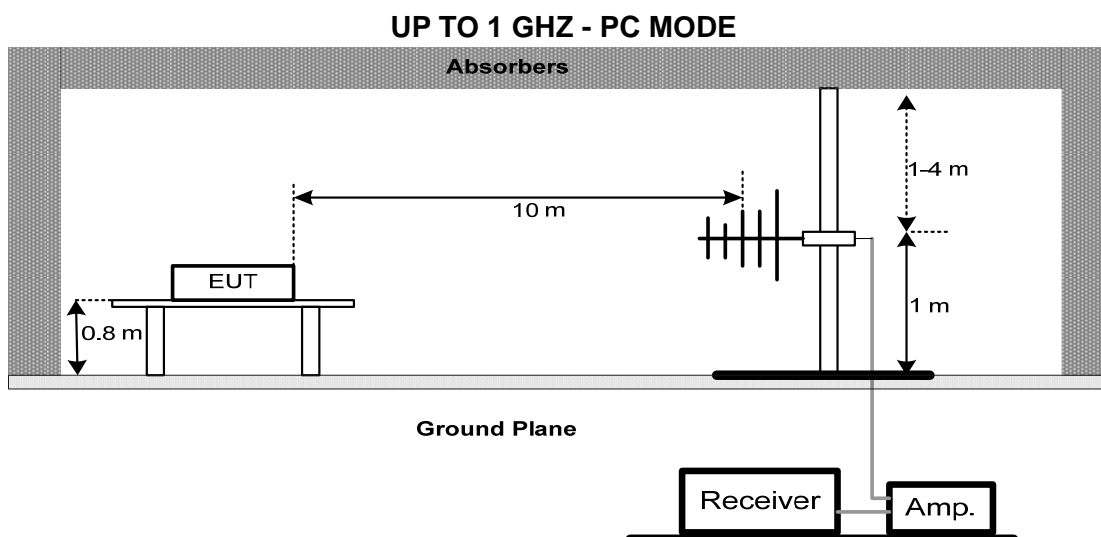

UP TO 1 GHZ - DVD MODE

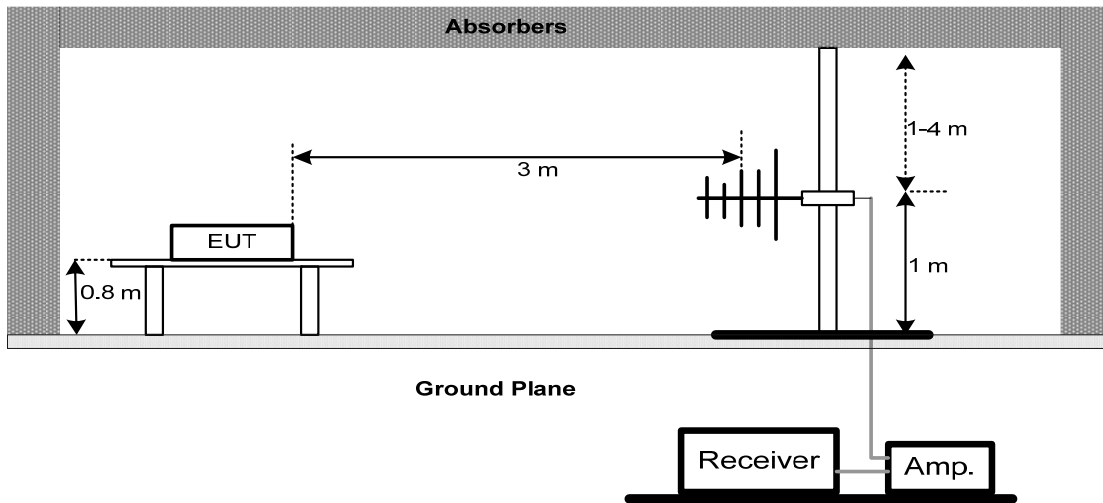

ABOVE 1 GHZ

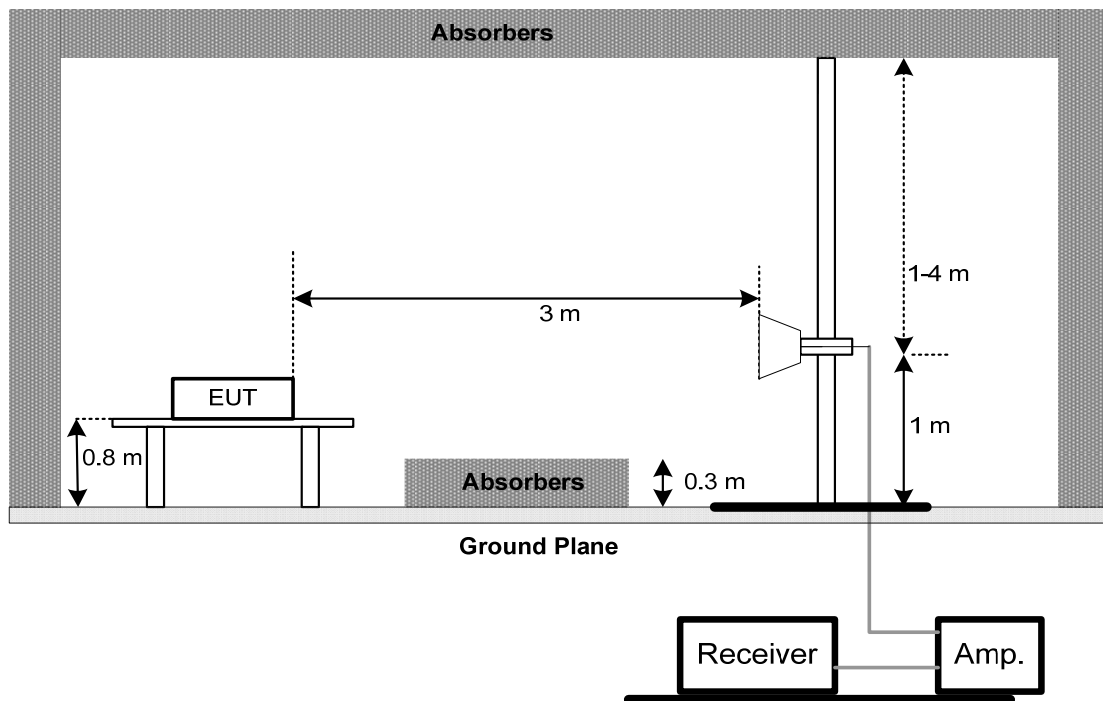

4.1.6 MEASUREMENT DISTANCE

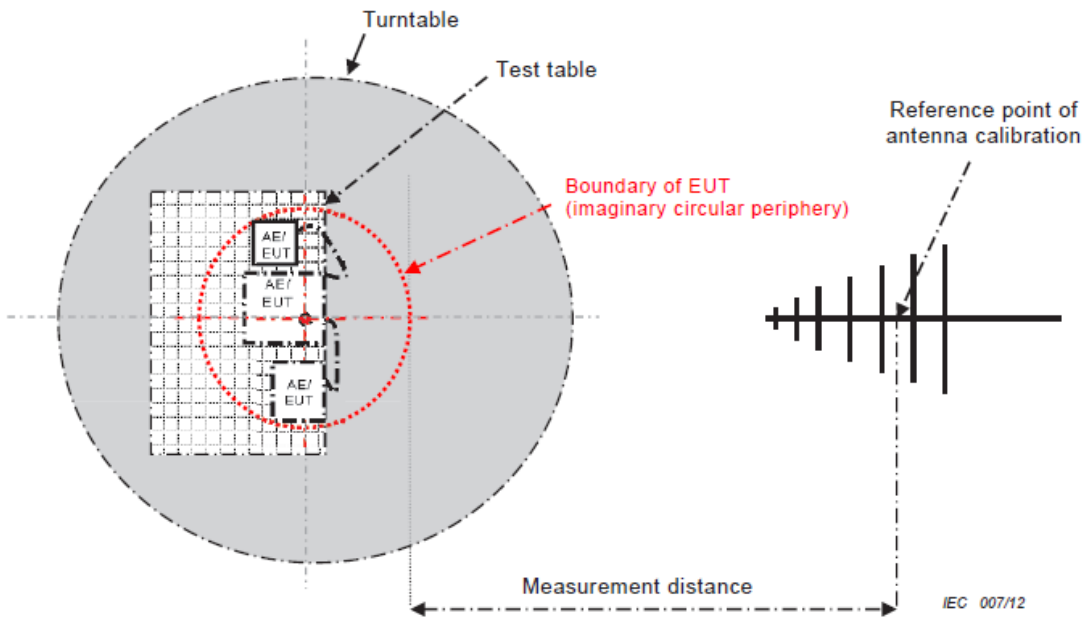

- 34 -

CISPR 32 © IEC:2012

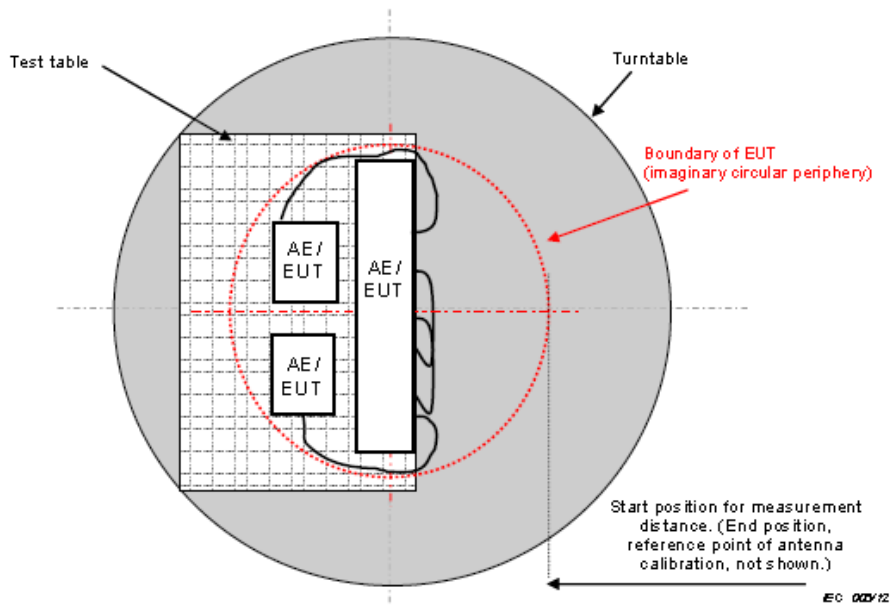
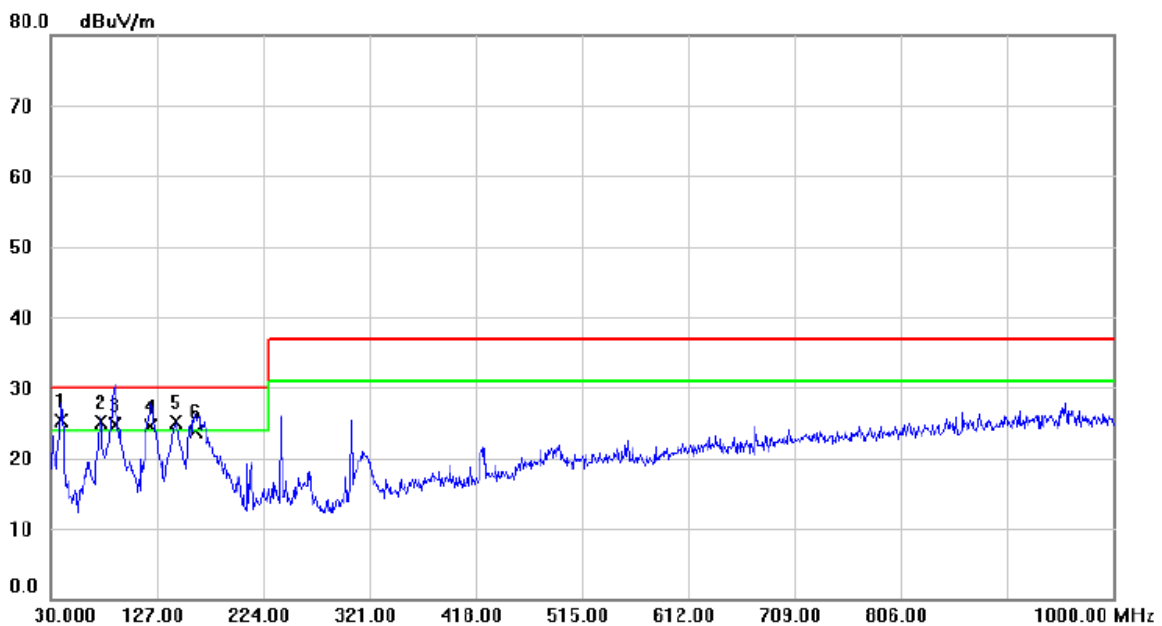

Figure C.2 – Boundary of EUT, Local AE and associated cabling

4.1.7 TEST RESULTS (UP TO 1 GHZ)

E.U.T :	LCD Monitor	Model Name :	238LM00009
Temperature :	24° C	Relative Humidity :	60%
Pressure :	1013 hPa	Test Voltage :	AC 230V/50Hz
Test Mode :	Display 2560*1440 144Hz 1.8m Horizontal Rotation Display+HDMI+Audio+USB cable (715G8083)	Polarization:	Vertical
Test Engineer :	Lucky Mao		



No.	Mk.	Freq. MHz	Reading Level dBuV	Correct Factor dB	Measure- ment dBuV/m	Limit dBuV/m	Margin dB	Detector	Comment
1	*	40.1850	41.03	-15.69	25.34	30.00	-4.66	QP	
2	!	76.0750	45.61	-20.55	25.06	30.00	-4.94	QP	
3	!	88.6850	44.25	-19.62	24.63	30.00	-5.37	QP	
4	!	121.6650	44.03	-19.43	24.60	30.00	-5.40	QP	
5	!	143.9750	43.16	-18.09	25.07	30.00	-4.93	QP	
6		162.4050	40.15	-16.35	23.80	30.00	-6.20	QP	

E.U.T :	LCD Monitor	Model Name :	238LM00009
Temperature :	24° C	Relative Humidity :	60%
Pressure :	1013 hPa	Test Voltage :	AC 230V/50Hz
Test Mode :	Display 2560*1440 144Hz 1.8m Horizontal Rotation Display+HDMI+Audio+USB cable (715G8083)	Polarization:	Horizontal
Test Engineer :	Lucky Mao		

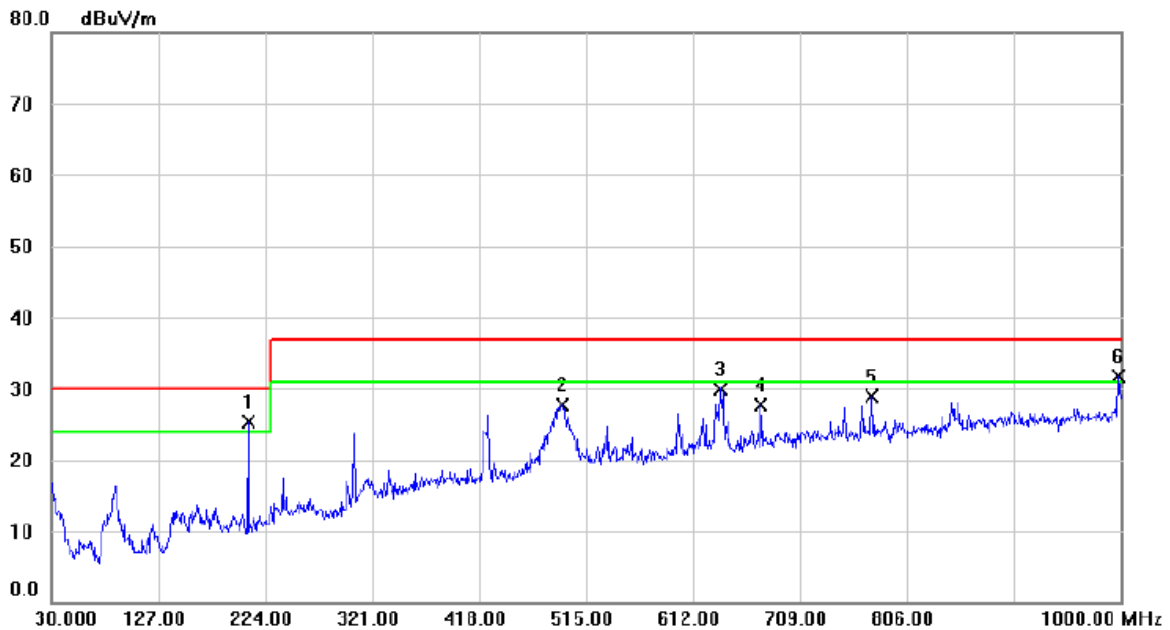

No.	Mk.	Freq. MHz	Reading Level dBuV	Correct Factor dB	Measure- ment dBuV/m	Limit dBuV/m	Margin dB	Detector	Comment
1	*	208.4800	40.12	-14.85	25.27	30.00	-4.73	QP	
2		493.6600	33.42	-5.77	27.65	37.00	-9.35	QP	
3		637.2200	32.99	-2.99	30.00	37.00	-7.00	QP	
4		673.1100	29.92	-2.30	27.62	37.00	-9.38	QP	
5		773.9900	29.35	-0.52	28.83	37.00	-8.17	QP	
6	!	998.0600	29.33	2.37	31.70	37.00	-5.30	QP	

E.U.T :	LCD Monitor	Model Name :	238LM00009
Temperature :	24° C	Relative Humidity :	60%
Pressure :	1013 hPa	Test Voltage :	AC 230V/50Hz
Test Mode :	HDMI 2560*1440 60Hz 1.8m Horizontal Rotation Display+HDMI+Audio+USB cable (715G8083)	Polarization:	Vertical
Test Engineer :	Lucky Mao		

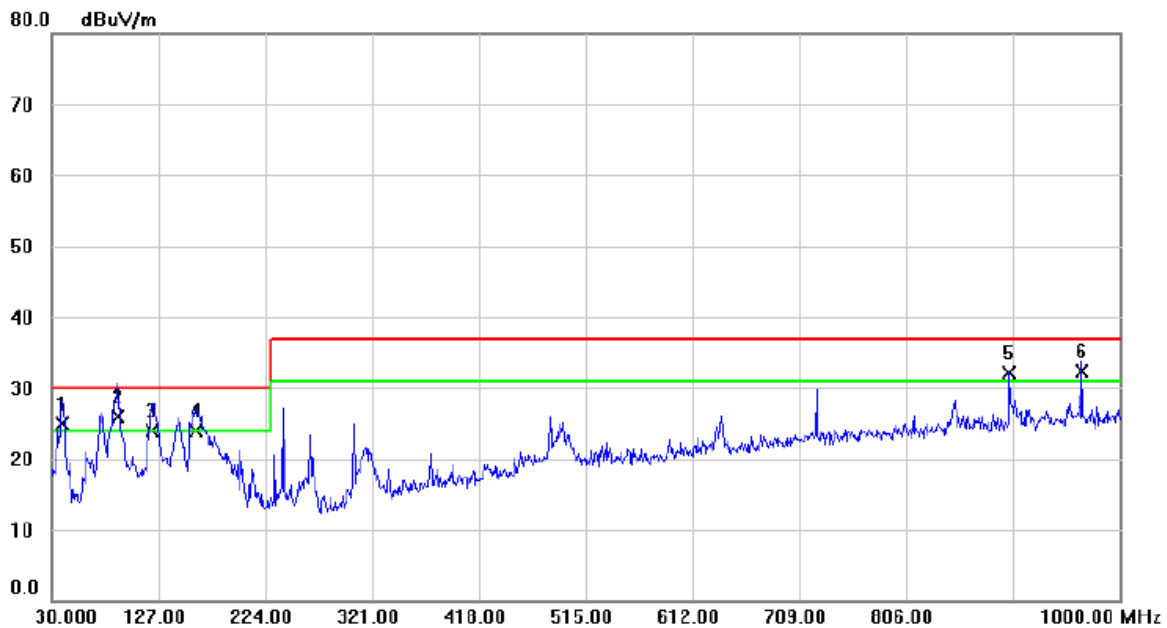

No.	Mk.	Freq. MHz	Reading Level dBuV	Correct Factor dB	Measure- ment dBuV/m	Limit dBuV/m	Margin dB	Detector	Comment
1	!	39.7000	40.32	-15.45	24.87	30.00	-5.13	QP	
2	*	90.1400	45.26	-19.45	25.81	30.00	-4.19	QP	
3		121.1800	43.26	-19.43	23.83	30.00	-6.17	QP	
4		160.9500	40.31	-16.36	23.95	30.00	-6.05	QP	
5	!	900.0900	31.12	0.89	32.01	37.00	-4.99	QP	
6	!	966.0500	30.69	1.56	32.25	37.00	-4.75	QP	

E.U.T :	LCD Monitor	Model Name :	238LM00009
Temperature :	24° C	Relative Humidity :	60%
Pressure :	1013 hPa	Test Voltage :	AC 230V/50Hz
Test Mode :	HDMI 2560*1440 60Hz 1.8m Horizontal Rotation Display+HDMI+Audio+USB cable (715G8083)	Polarization:	Horizontal
Test Engineer :	Lucky Mao		

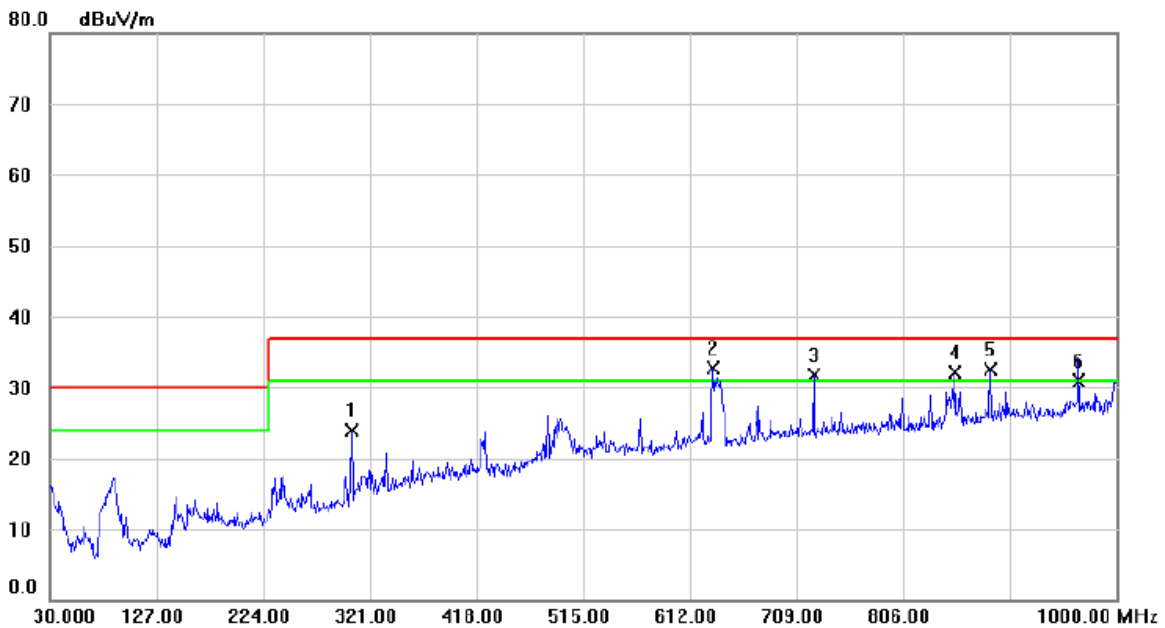

No.	Mk.	Freq. MHz	Reading Level dBuV	Correct Factor dB	Measure- ment dBuV/m	Limit dBuV/m	Margin dB	Detector	Comment
1		304.5100	34.95	-11.00	23.95	37.00	-13.05	QP	
2	*	633.3400	35.62	-2.95	32.67	37.00	-4.33	QP	
3	!	724.5200	32.82	-1.18	31.64	37.00	-5.36	QP	
4	!	853.5300	31.61	0.51	32.12	37.00	-4.88	QP	
5	!	885.5400	31.26	1.29	32.55	37.00	-4.45	QP	
6		966.0500	28.65	2.19	30.84	37.00	-6.16	QP	

E.U.T :	LCD Monitor	Model Name :	238LM00009
Temperature :	24° C	Relative Humidity :	60%
Pressure :	1013 hPa	Test Voltage :	AC 230V/50Hz
Test Mode :	HDMI 1080P 1.8m Horizontal Rotation (715G8083)	Polarization:	Vertical
Test Engineer :	Lucky Mao		

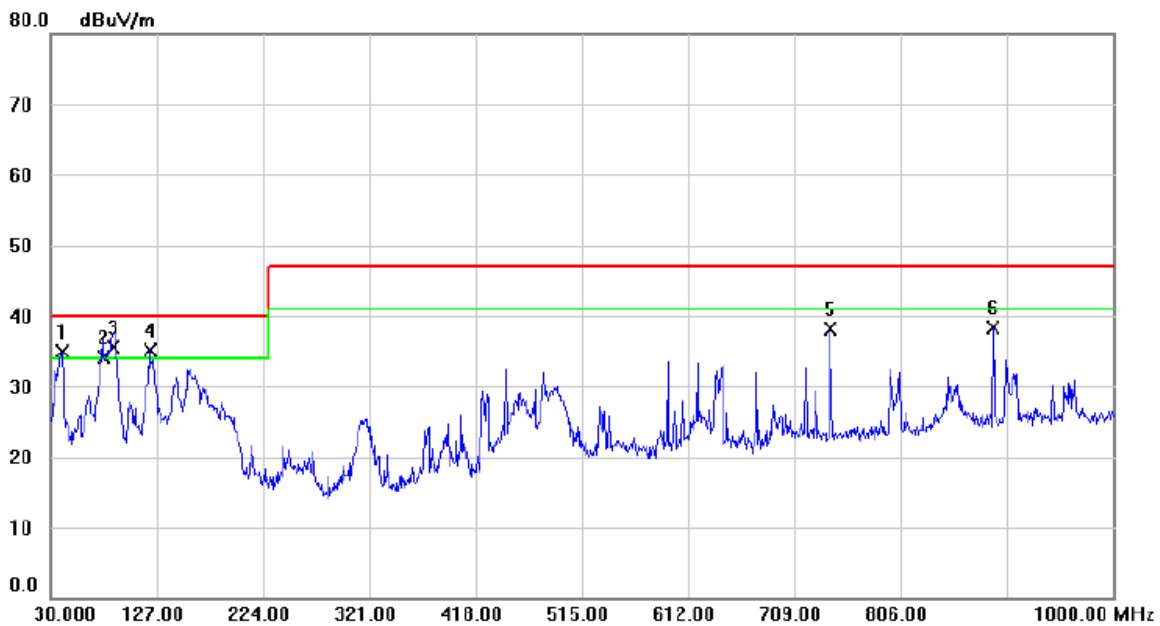

No.	Mk.	Freq. MHz	Reading Level dBuV	Correct Factor dB	Measure- ment dBuV/m	Limit dBuV/m	Margin dB	Detector	Comment
1	!	40.6700	50.68	-15.82	34.86	40.00	-5.14	QP	
2	!	78.0150	54.69	-20.62	34.07	40.00	-5.93	QP	
3	*	87.7150	55.24	-19.74	35.50	40.00	-4.50	QP	
4	!	120.6950	54.63	-19.43	35.20	40.00	-4.80	QP	
5		742.4650	39.61	-1.49	38.12	47.00	-8.88	QP	
6		890.8750	37.71	0.68	38.39	47.00	-8.61	QP	

E.U.T :	LCD Monitor	Model Name :	238LM00009
Temperature :	24° C	Relative Humidity :	60%
Pressure :	1013 hPa	Test Voltage :	AC 230V/50Hz
Test Mode :	HDMI 1080P 1.8m Horizontal Rotation (715G8083)	Polarization:	Horizontal
Test Engineer :	Lucky Mao		

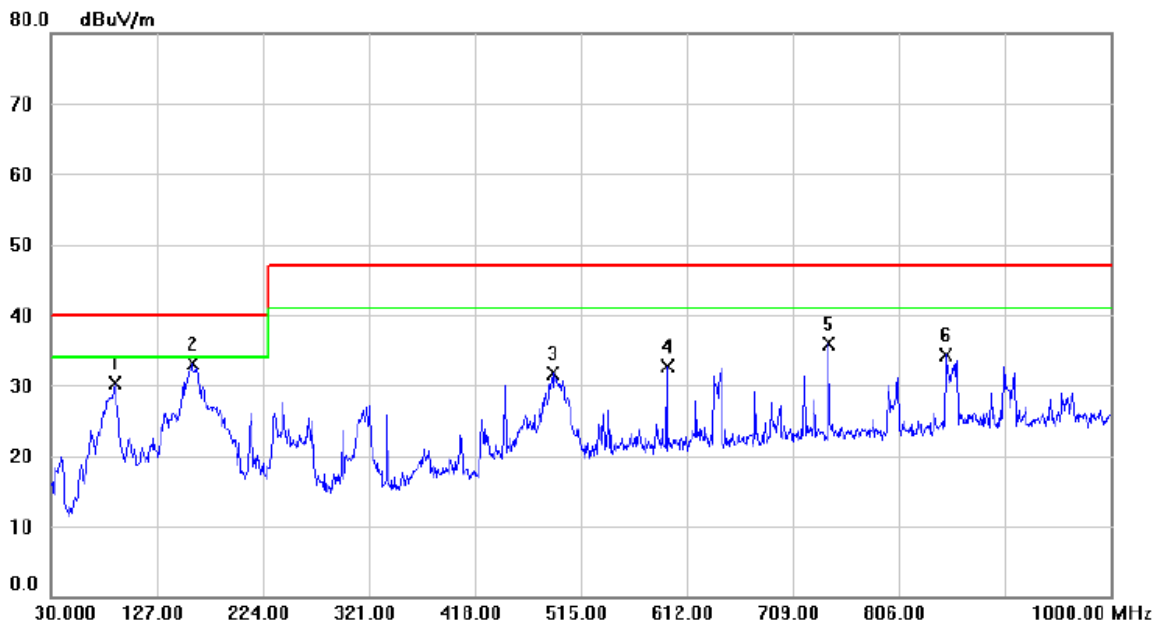

No.	Mk.	Freq. MHz	Reading Level dBuV	Correct Factor dB	Measure- ment dBuV/m	Limit dBuV/m	Margin dB	Detector	Comment
1		88.6850	49.88	-19.62	30.26	40.00	-9.74	QP	
2	*	159.4950	49.59	-16.41	33.18	40.00	-6.82	QP	
3		490.2650	37.78	-5.99	31.79	47.00	-15.21	QP	
4		594.0550	36.96	-4.33	32.63	47.00	-14.37	QP	
5		742.4650	37.41	-1.49	35.92	47.00	-11.08	QP	
6		849.6500	34.66	-0.26	34.40	47.00	-12.60	QP	

E.U.T :	LCD Monitor	Model Name :	238LM00009
Temperature :	25° C	Relative Humidity :	53%
Pressure :	1013 hPa	Test Voltage :	AC 230V/50Hz
Test Mode :	HDMI 2560*1440 60Hz Horizontal Rotation 1.5m Display+HDMI+Audio+USB cable (715G8083)		
Test Engineer :	Lucky Mao		

Vertical

80.0 dBuV/m

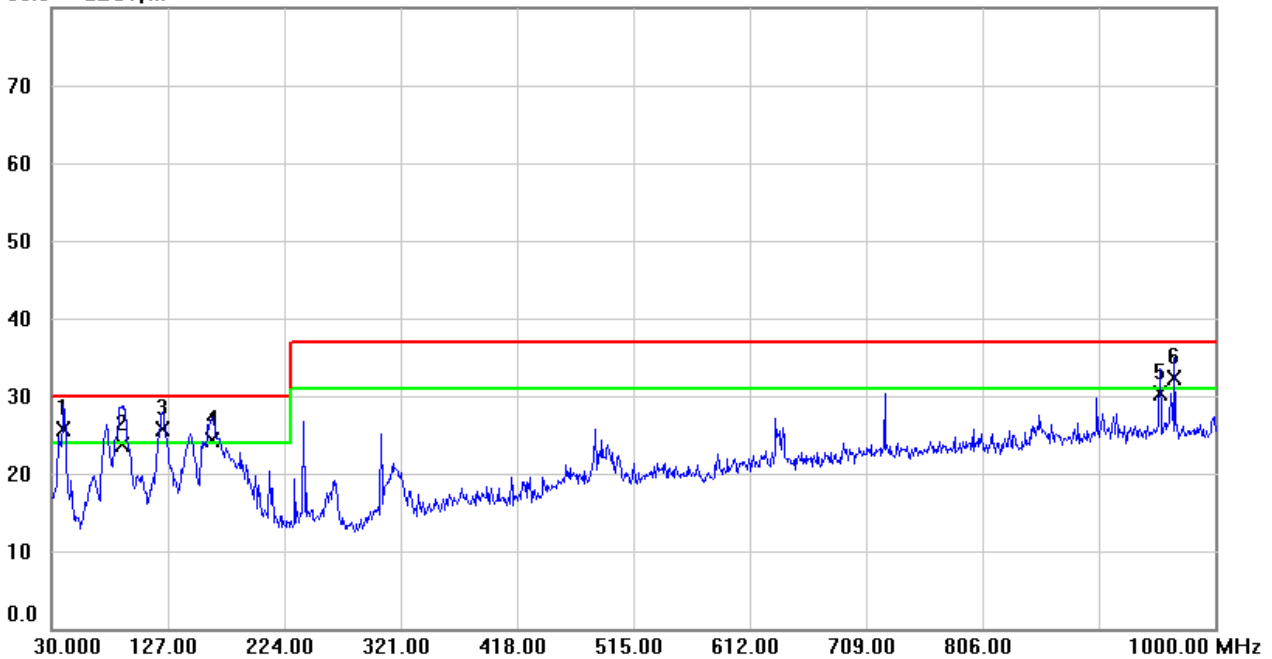

Horizontal

80.0 dBuV/m

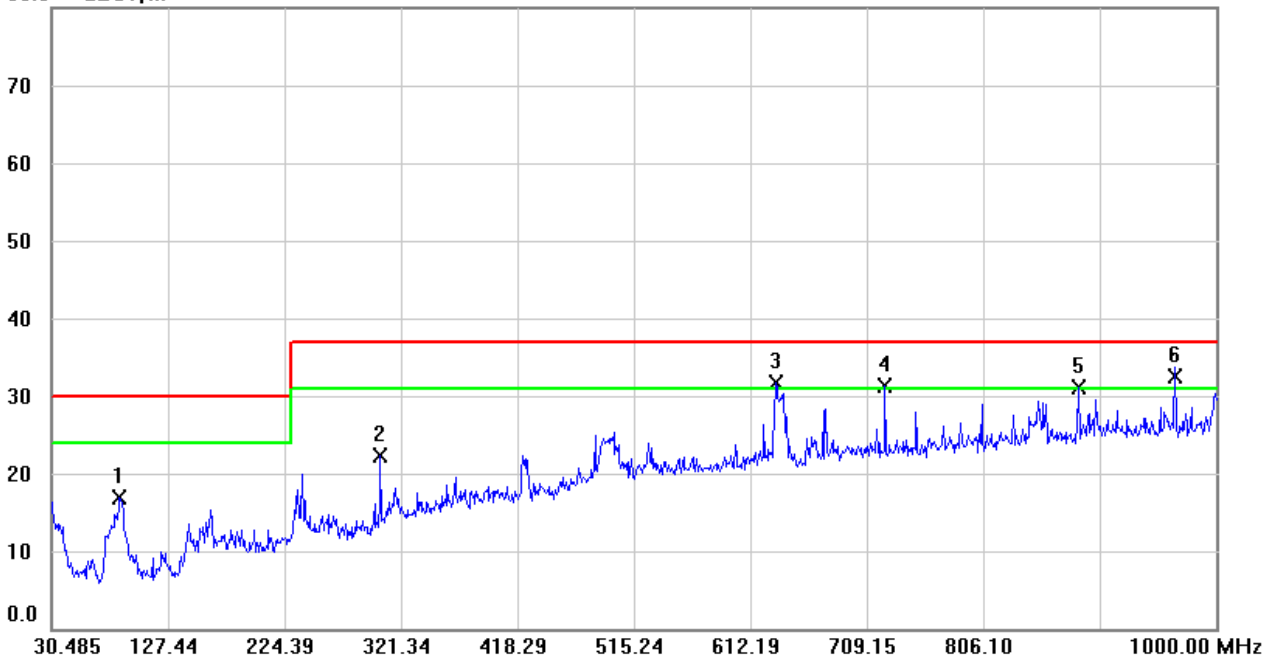

E.U.T :	LCD Monitor	Model Name :	238LM00009
Temperature :	25° C	Relative Humidity :	53%
Pressure :	1013 hPa	Test Voltage :	AC 230V/50Hz
Test Mode :	HDMI 2560*1440 60Hz Vertical Rotation 1.5m Display+HDMI+Audio+USB cable (715G8083)		
Test Engineer :	Lucky Mao		

Vertical

80.0 dBuV/m

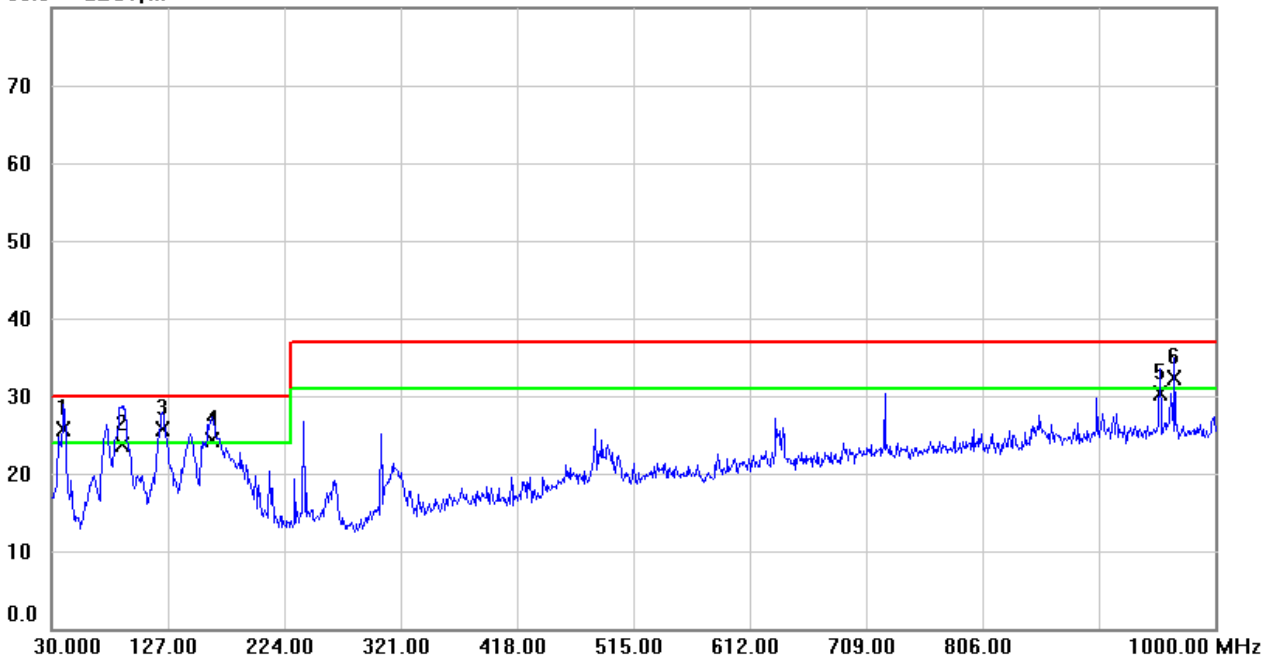

Horizontal

80.0 dBuV/m

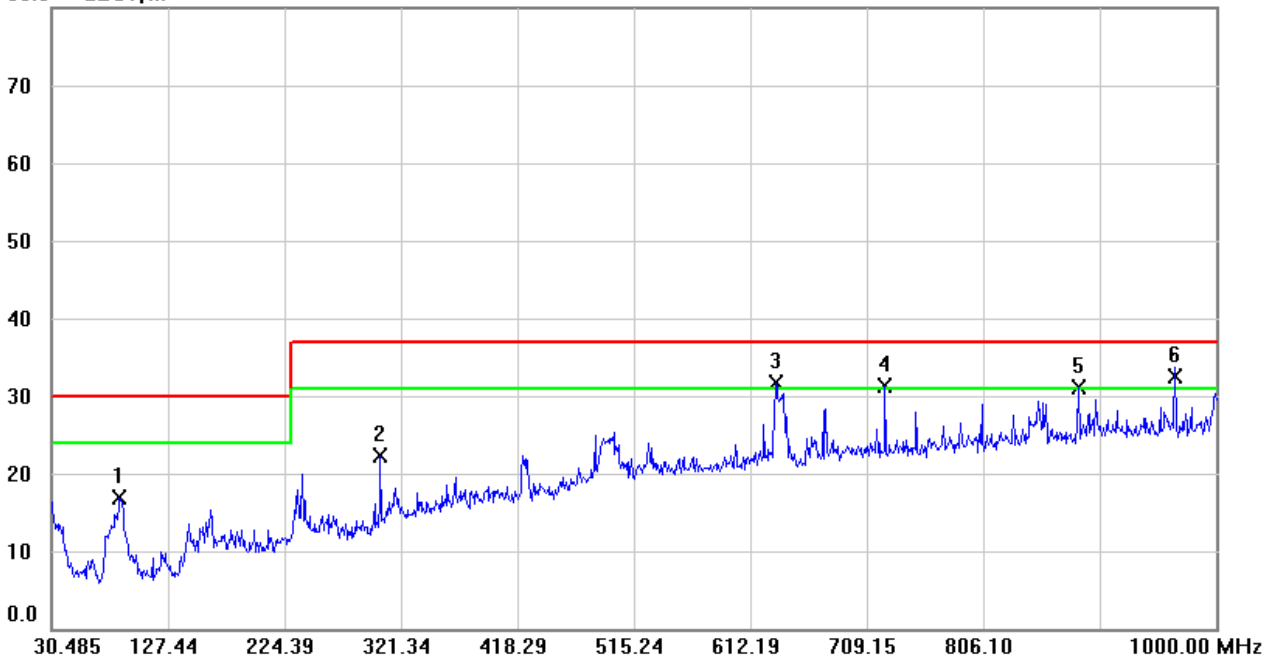

E.U.T :	LCD Monitor	Model Name :	238LM00009
Temperature :	25° C	Relative Humidity :	53%
Pressure :	1013 hPa	Test Voltage :	AC 230V/50Hz
Test Mode :	HDMI 2560*1440 60Hz Horizontal Rotation 1.2m Display+HDMI+Audio+USB cable (715G8083)		
Test Engineer :	Lucky Mao		

Vertical

80.0 dBuV/m

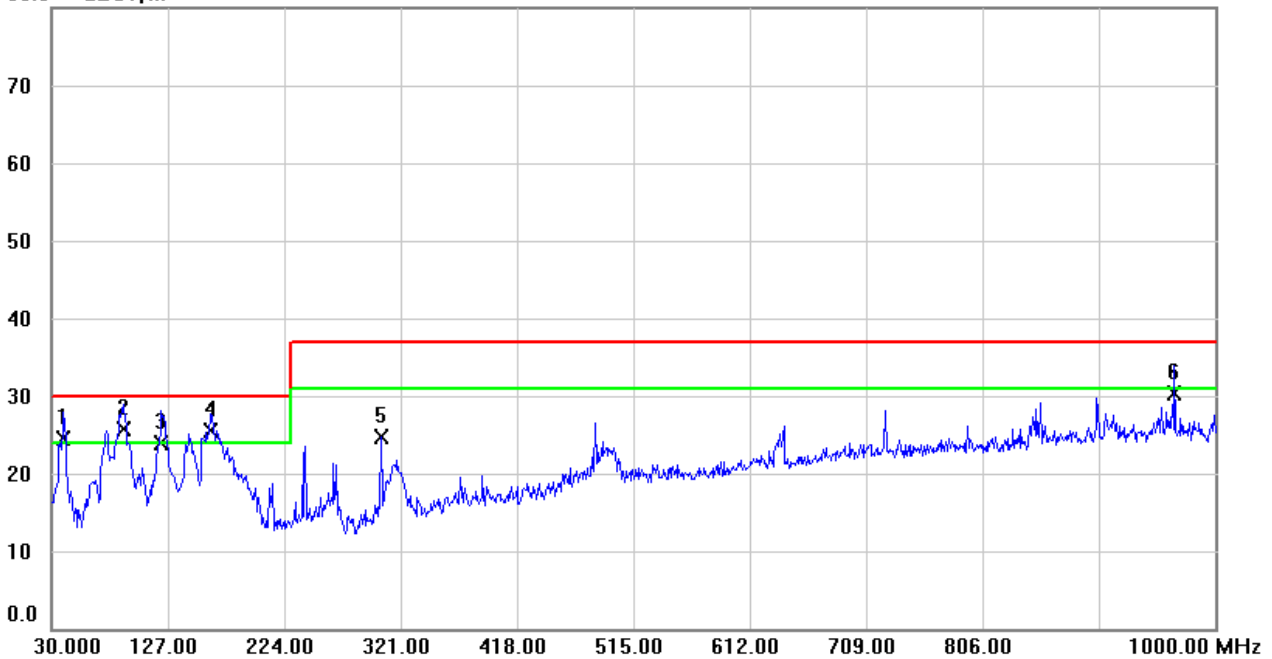

Horizontal

80.0 dBuV/m

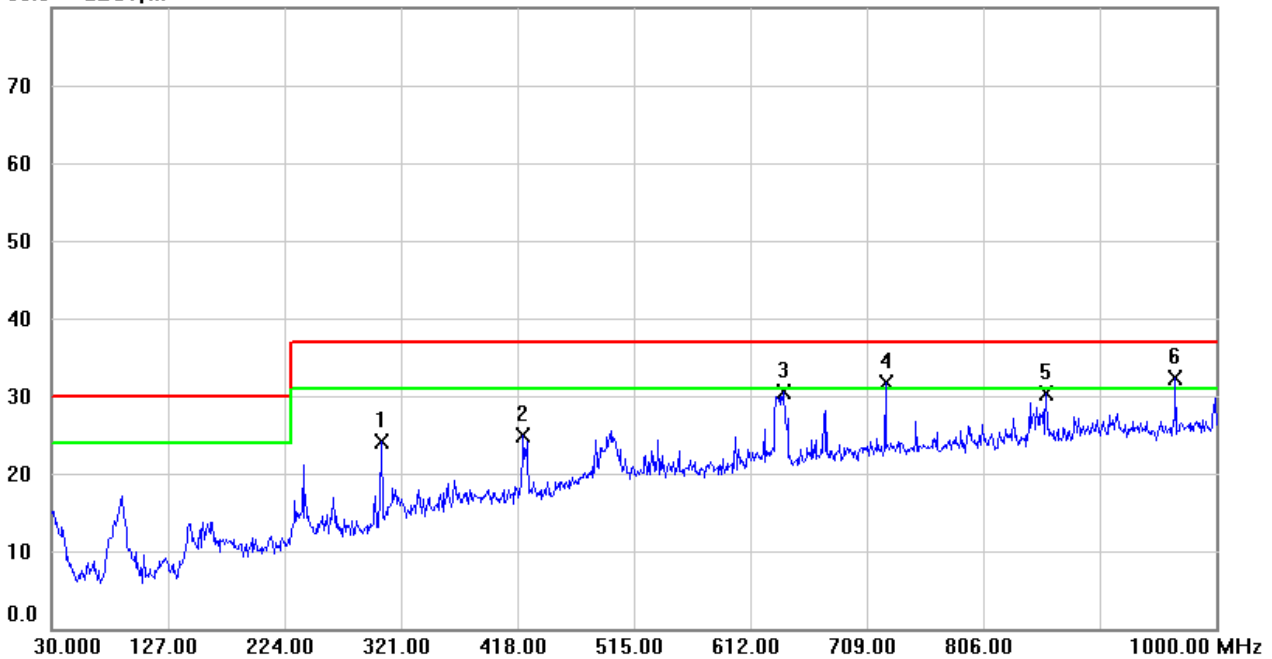

E.U.T :	LCD Monitor	Model Name :	238LM00009
Temperature :	25° C	Relative Humidity :	53%
Pressure :	1013 hPa	Test Voltage :	AC 230V/50Hz
Test Mode :	HDMI 2560*1440 60Hz Vertical Rotation 1.2m Display+HDMI+Audio+USB cable (715G8083)		
Test Engineer :	Lucky Mao		

Vertical

80.0 dBuV/m

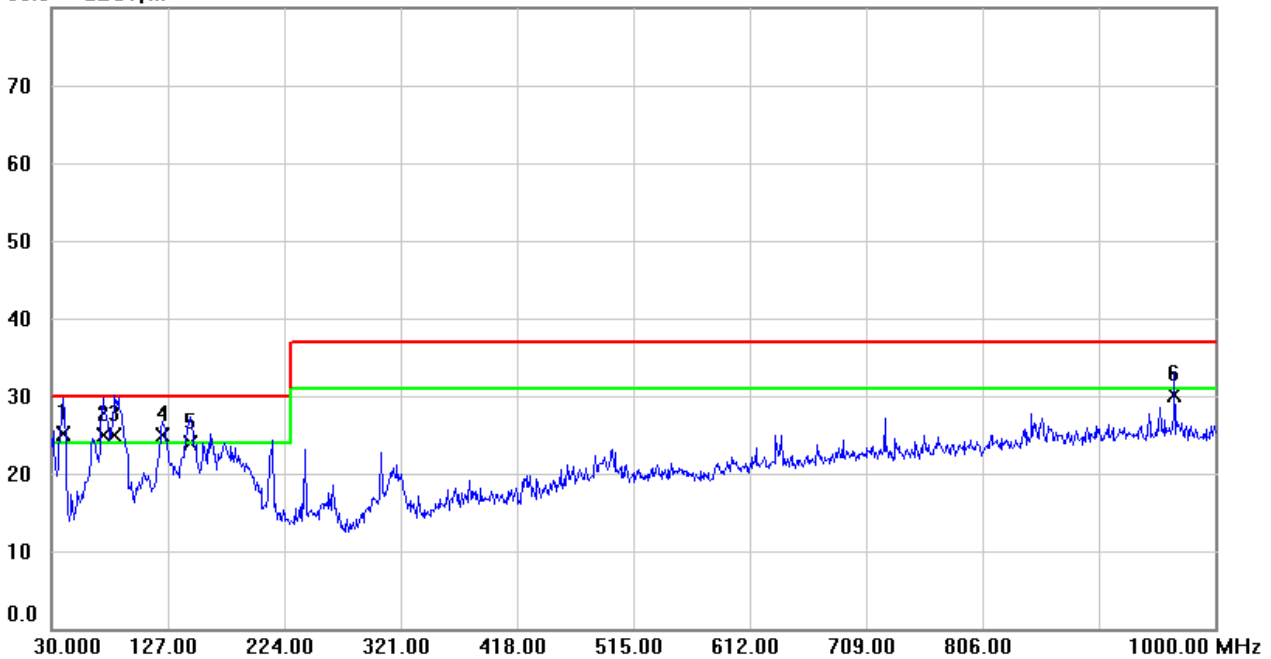

Horizontal

80.0 dBuV/m

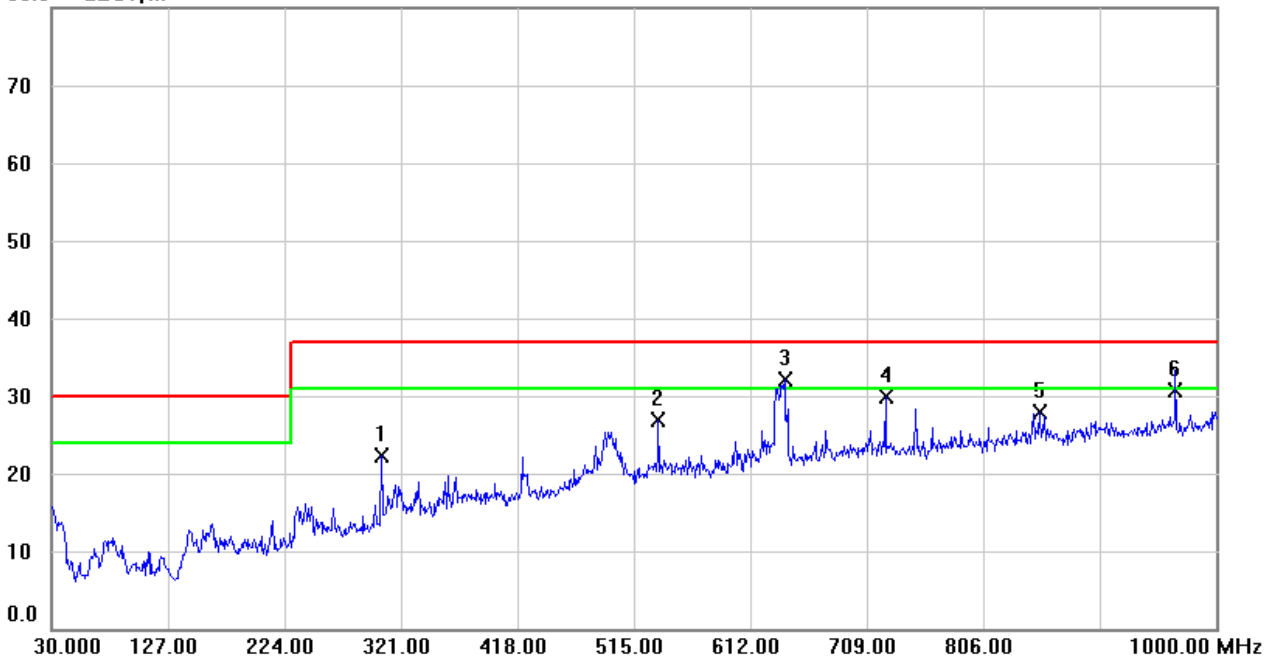

E.U.T :	LCD Monitor	Model Name :	238LM00009
Temperature :	24° C	Relative Humidity :	60%
Pressure :	1013 hPa	Test Voltage :	AC 230V/50Hz
Test Mode :	Display 2560*1440 144Hz 1.8m Horizontal Rotation D-SUB+DVI+HDMI+Display+Audio +USB cable (715G8055)	Polarization:	Vertical
Test Engineer :	Lucky Mao		

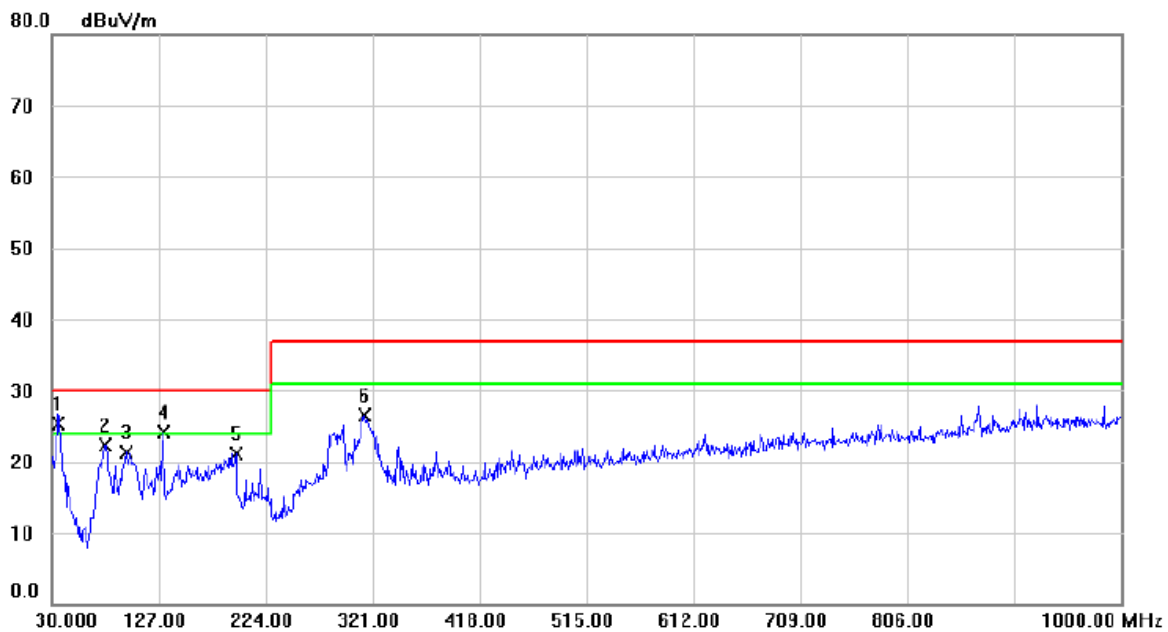

No.	Mk.	Freq. MHz	Reading Level dBuV	Correct Factor dB	Measure- ment dBuV/m	Limit dBuV/m	Margin dB	Detector	Comment
1	*	36.3050	38.89	-13.50	25.39	30.00	-4.61	QP	
2		78.5000	43.03	-20.64	22.39	30.00	-7.61	QP	
3		98.3850	39.83	-18.44	21.39	30.00	-8.61	QP	
4	!	131.3650	43.56	-19.37	24.19	30.00	-5.81	QP	
5		196.8400	36.79	-15.61	21.18	30.00	-8.82	QP	
6		313.2400	37.46	-10.86	26.60	37.00	-10.40	QP	

E.U.T :	LCD Monitor	Model Name :	238LM00009
Temperature :	24° C	Relative Humidity :	60%
Pressure :	1013 hPa	Test Voltage :	AC 230V/50Hz
Test Mode :	Display 2560*1440 144Hz 1.8m Horizontal Rotation D-SUB+DVI+HDMI+Display+Audio +USB cable (715G8055)	Polarization:	Horizontal
Test Engineer :	Lucky Mao		

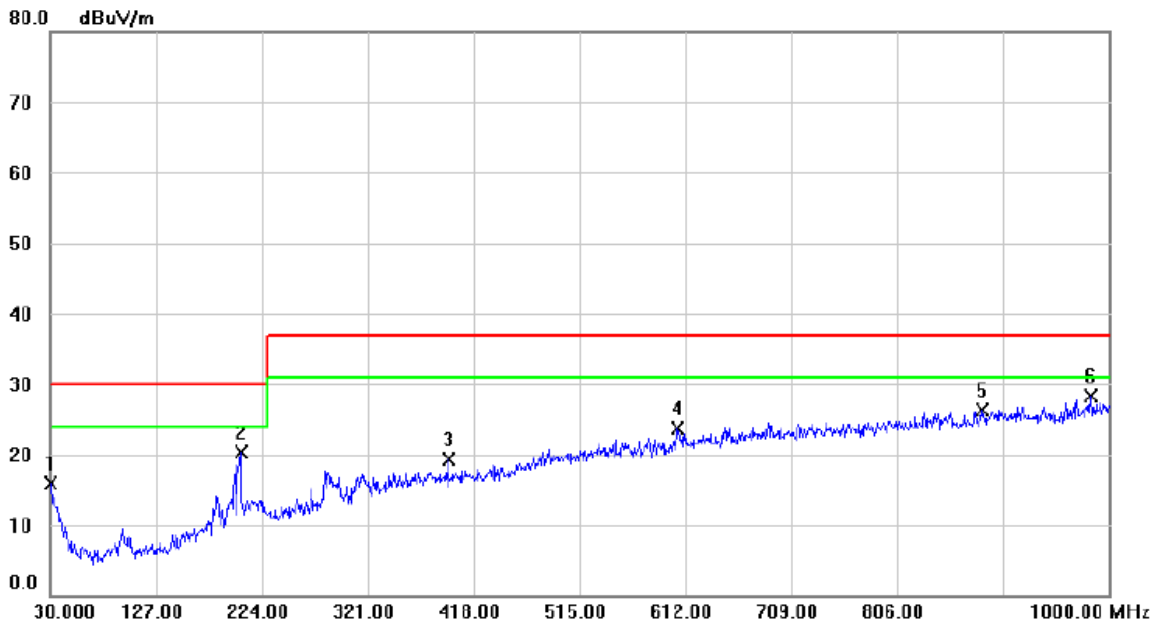

No.	Mk.	Freq. MHz	Reading Level dBuV	Correct Factor dB	Measure- ment dBuV/m	Limit dBuV/m	Margin dB	Detector	Comment
1		30.9700	26.18	-10.24	15.94	30.00	-14.06	QP	
2		204.6000	35.39	-15.11	20.28	30.00	-9.72	QP	
3		394.7200	27.21	-7.82	19.39	37.00	-17.61	QP	
4		605.2100	27.13	-3.49	23.64	37.00	-13.36	QP	
5		883.6000	25.06	1.23	26.29	37.00	-10.71	QP	
6	*	983.5100	25.92	2.30	28.22	37.00	-8.78	QP	

E.U.T :	LCD Monitor	Model Name :	238LM00009
Temperature :	24° C	Relative Humidity :	60%
Pressure :	1013 hPa	Test Voltage :	AC 230V/50Hz
Test Mode :	HDMI 2 2560*1440 144Hz 1.8m Horizontal Rotation D-SUB+DVI+HDMI+Display+Audio +USB cable (715G8055)	Polarization:	Vertical
Test Engineer :	Lucky Mao		

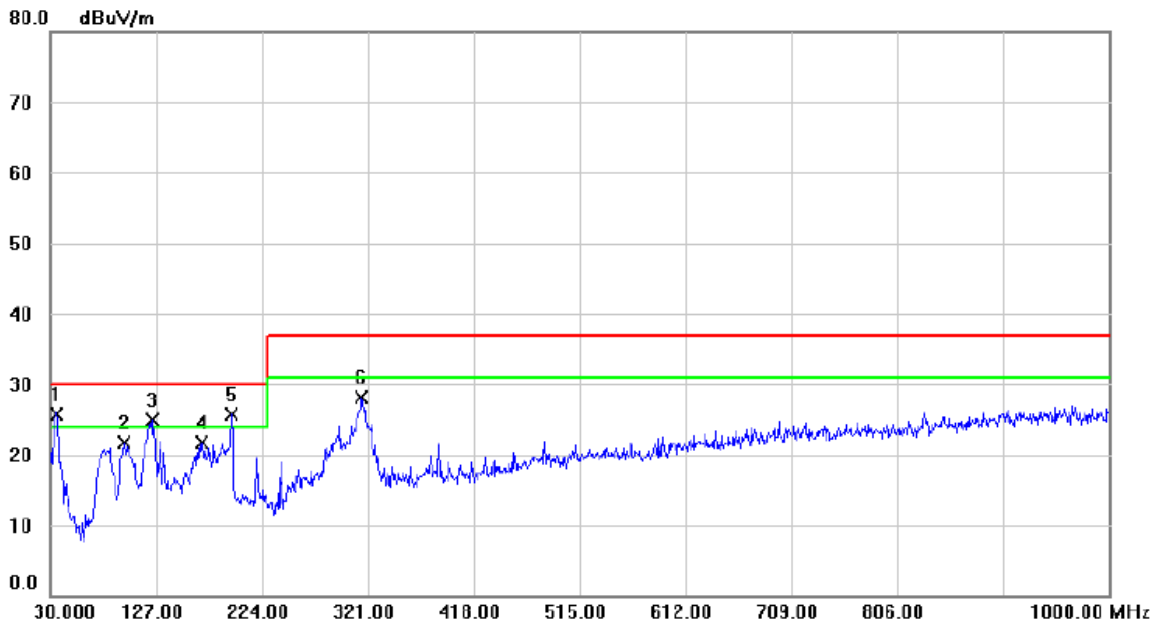

No.	Mk.	Freq. MHz	Reading Level dBuV	Correct Factor dB	Measure- ment dBuV/m	Limit dBuV/m	Margin dB	Detector	Comment
1	*	36.3050	39.30	-13.50	25.80	30.00	-4.20	QP	
2		97.4150	40.27	-18.56	21.71	30.00	-8.29	QP	
3	!	123.1200	44.45	-19.45	25.00	30.00	-5.00	QP	
4		168.7100	38.04	-16.30	21.74	30.00	-8.26	QP	
5	!	196.3550	41.34	-15.59	25.75	30.00	-4.25	QP	
6		315.6650	38.90	-10.75	28.15	37.00	-8.85	QP	

E.U.T :	LCD Monitor	Model Name :	238LM00009
Temperature :	24° C	Relative Humidity :	60%
Pressure :	1013 hPa	Test Voltage :	AC 230V/50Hz
Test Mode :	HDMI 2 2560*1440 144Hz 1.8m Horizontal Rotation D-SUB+DVI+HDMI+Display+Audio +USB cable (715G8055)	Polarization:	Horizontal
Test Engineer :	Lucky Mao		

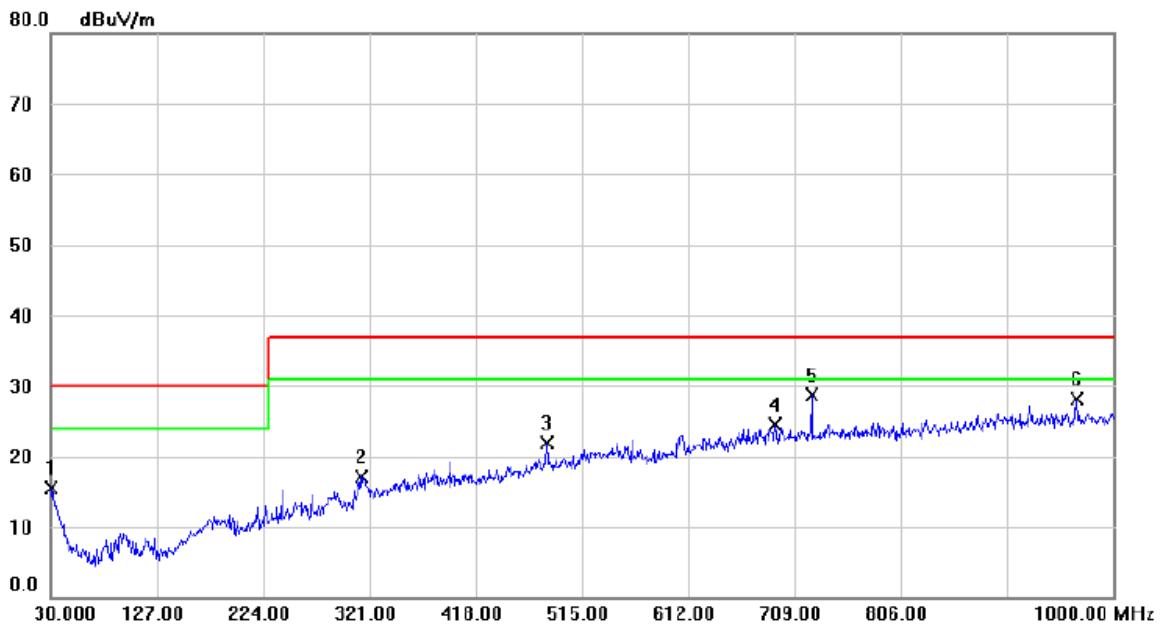

No.	Mk.	Freq. MHz	Reading Level dBuV	Correct Factor dB	Measure- ment dBuV/m	Limit dBuV/m	Margin dB	Detector	Comment
1		30.0000	25.17	-9.69	15.48	30.00	-14.52	QP	
2		313.2400	27.60	-10.53	17.07	37.00	-19.93	QP	
3		482.9900	27.70	-5.74	21.96	37.00	-15.04	QP	
4		691.5400	26.23	-1.79	24.44	37.00	-12.56	QP	
5	*	724.5200	29.91	-1.18	28.73	37.00	-8.27	QP	
6		967.0200	25.84	2.20	28.04	37.00	-8.96	QP	

E.U.T :	LCD Monitor	Model Name :	238LM00009
Temperature :	24° C	Relative Humidity :	60%
Pressure :	1013 hPa	Test Voltage :	AC 230V/50Hz
Test Mode :	HDMI 2 1080P 1.8m Horizontal Rotation D-SUB+DVI+HDMI+Display+Audio +USB cable (715G8055)	Polarization:	Vertical
Test Engineer :	Lucky Mao		

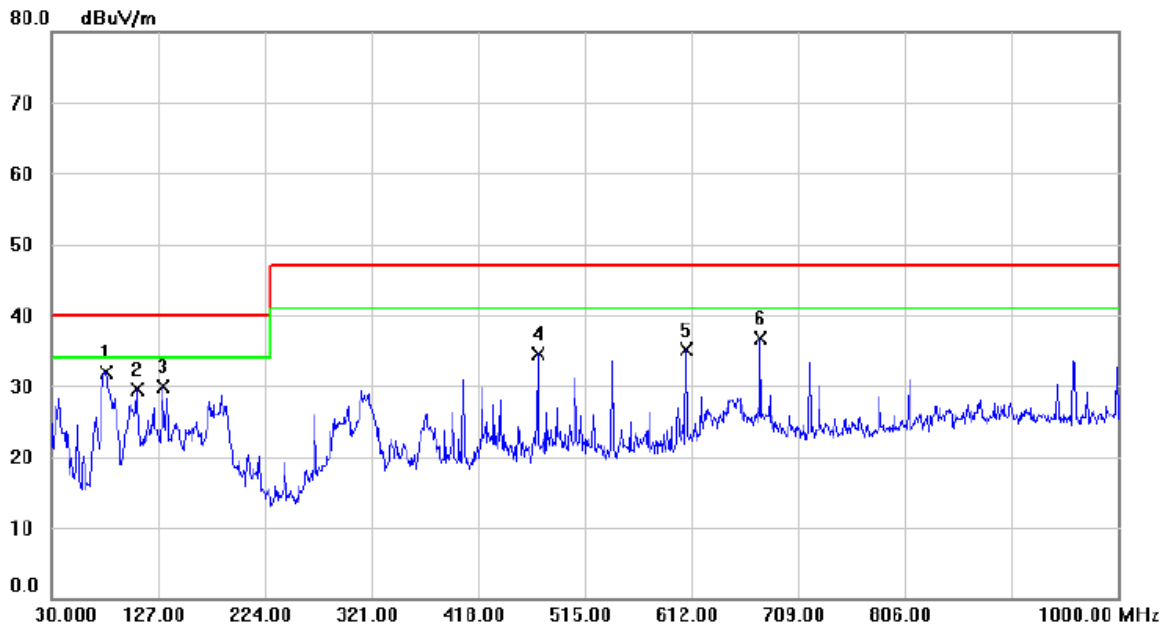

No.	Mk.	Freq. MHz	Reading Level dBuV	Correct Factor dB	Measure- ment dBuV/m	Limit dBuV/m	Margin dB	Detector	Comment
1	*	79.4700	52.64	-20.66	31.98	40.00	-8.02	QP	
2		108.0850	48.18	-18.72	29.46	40.00	-10.54	QP	
3		131.3650	49.30	-19.37	29.93	40.00	-10.07	QP	
4		472.3200	40.60	-6.07	34.53	47.00	-12.47	QP	
5		607.6350	38.90	-3.81	35.09	47.00	-11.91	QP	
6		675.0500	39.31	-2.66	36.65	47.00	-10.35	QP	

E.U.T :	LCD Monitor	Model Name :	238LM00009
Temperature :	24° C	Relative Humidity :	60%
Pressure :	1013 hPa	Test Voltage :	AC 230V/50Hz
Test Mode :	HDMI 2 1080P 1.8m Horizontal Rotation D-SUB+DVI+HDMI+Display+Audio +USB cable (715G8055)	Polarization:	Horizontal
Test Engineer :	Lucky Mao		

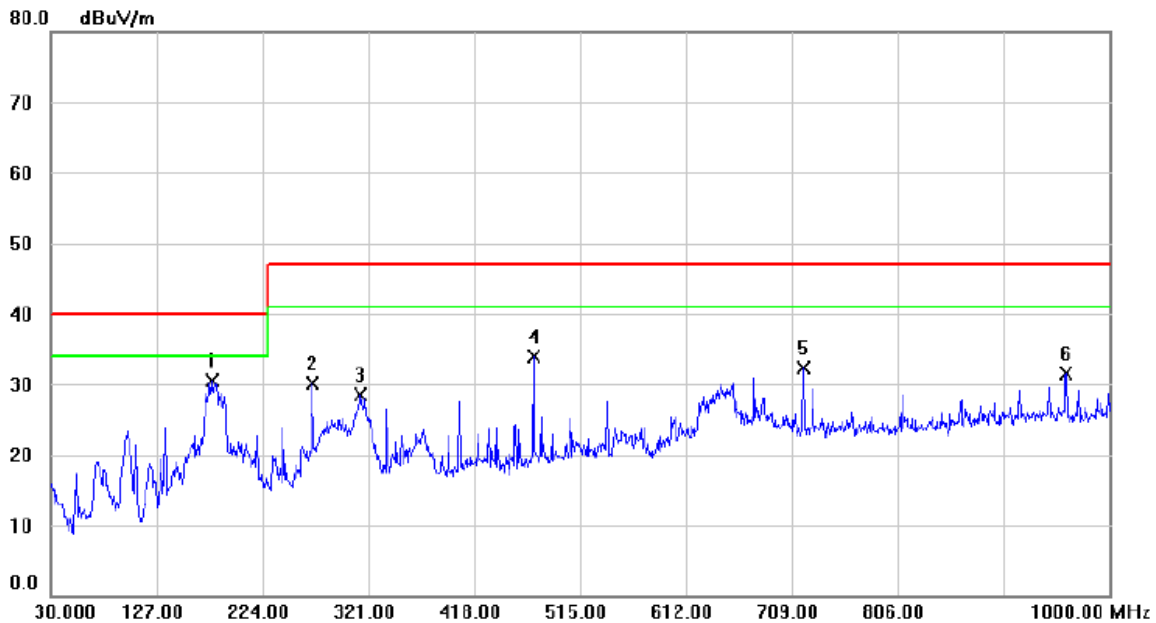

No.	Mk.	Freq. MHz	Reading Level dBuV	Correct Factor dB	Measure- ment dBuV/m	Limit dBuV/m	Margin dB	Detector	Comment
1	*	177.9250	46.35	-15.80	30.55	40.00	-9.45	QP	
2		270.0750	42.15	-12.08	30.07	47.00	-16.93	QP	
3		314.2100	39.33	-10.81	28.52	47.00	-18.48	QP	
4		472.3200	40.03	-6.07	33.96	47.00	-13.04	QP	
5		720.1550	34.05	-1.69	32.36	47.00	-14.64	QP	
6		960.2300	29.98	1.54	31.52	47.00	-15.48	QP	

E.U.T :	LCD Monitor	Model Name :	238LM00009
Temperature :	25° C	Relative Humidity :	53%
Pressure :	1013 hPa	Test Voltage :	AC 230V/50Hz
Test Mode :	HDMI 2 2560*1440 144Hz Horizontal Rotation 1.5m D-SUB+DVI+HDMI+Display+Audio+USB cable (715G8055)		
Test Engineer :	Lucky Mao		

Vertical

80.0 dBuV/m

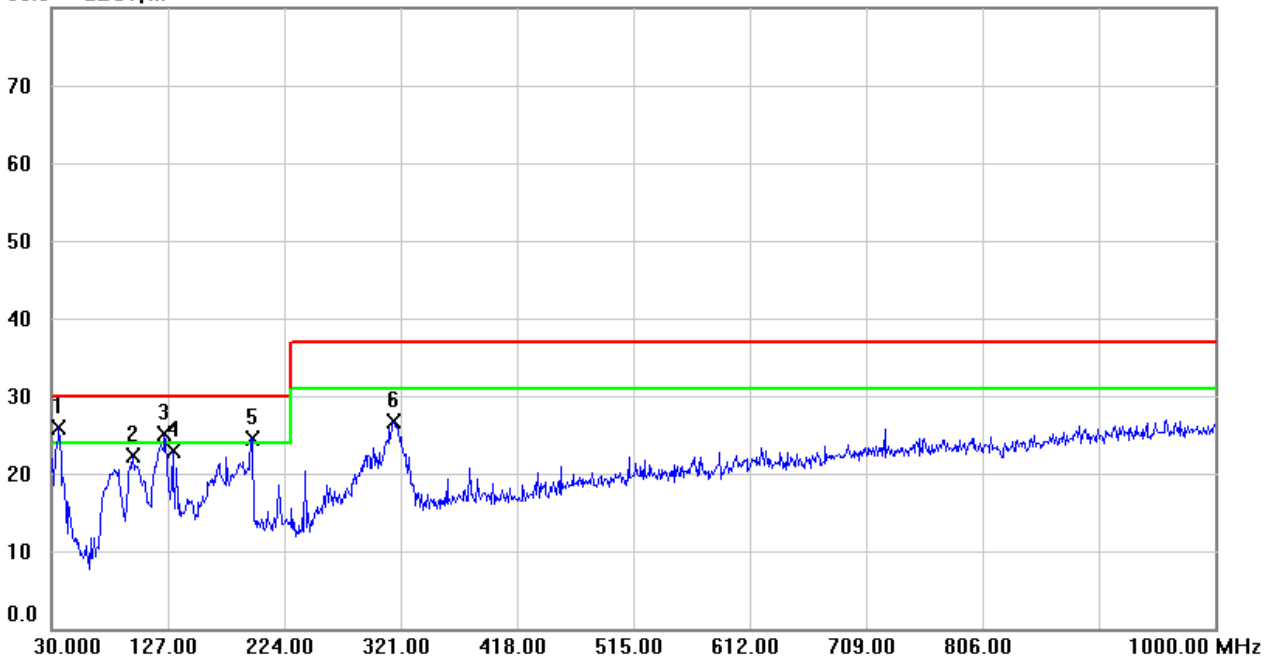

Horizontal

80.0 dBuV/m

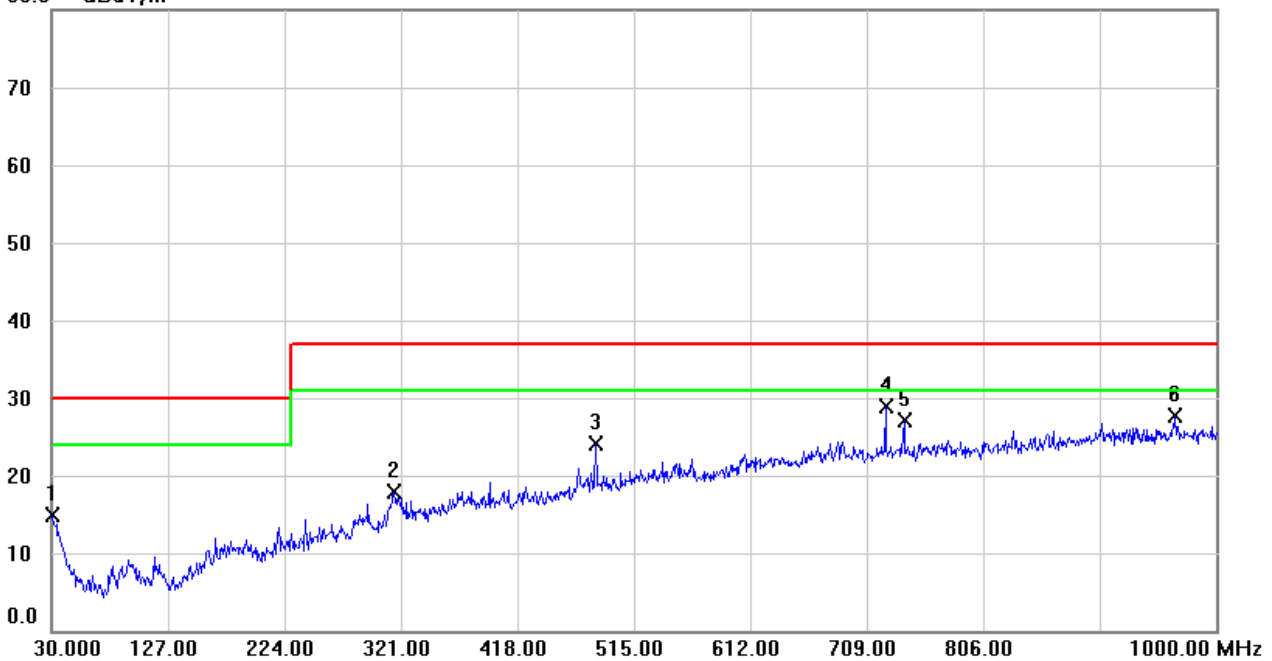

E.U.T :	LCD Monitor	Model Name :	238LM00009
Temperature :	25° C	Relative Humidity :	53%
Pressure :	1013 hPa	Test Voltage :	AC 230V/50Hz
Test Mode :	HDMI 2 2560*1440 144Hz Vertical Rotation 1.5m D-SUB+DVI+HDMI+Display+Audio+USB cable (715G8055)		
Test Engineer :	Lucky Mao		

Vertical

80.0 dBuV/m

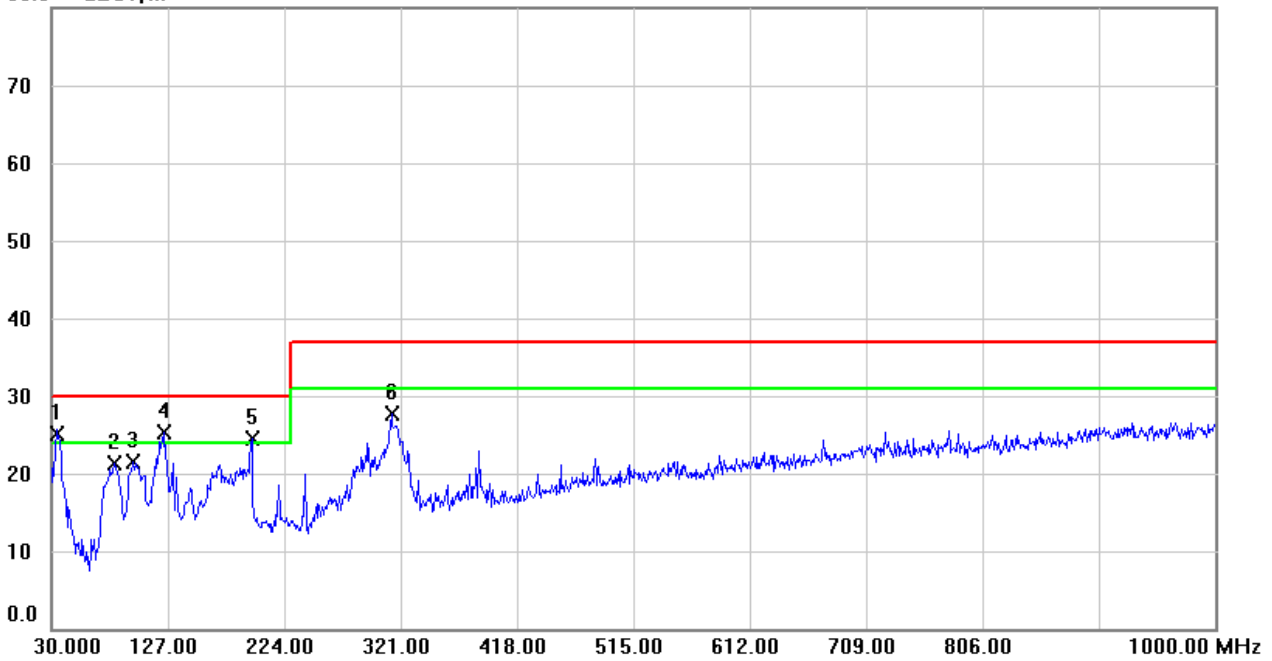

Horizontal

80.0 dBuV/m

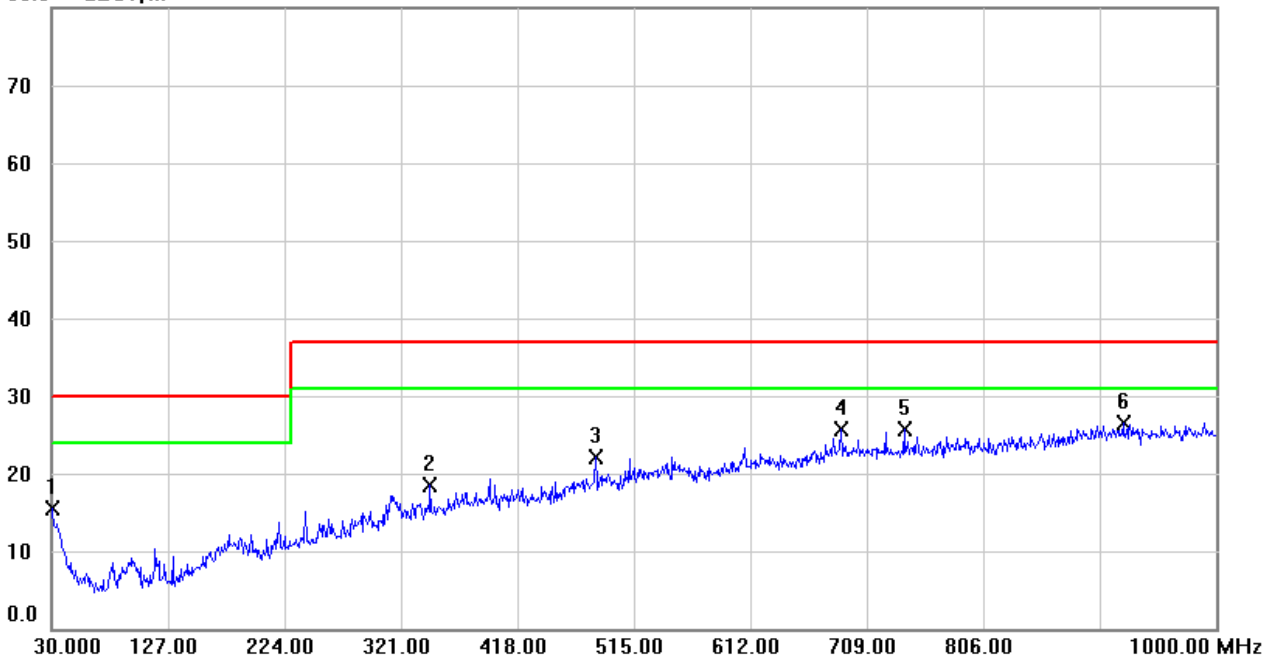

E.U.T :	LCD Monitor	Model Name :	238LM00009
Temperature :	25° C	Relative Humidity :	53%
Pressure :	1013 hPa	Test Voltage :	AC 230V/50Hz
Test Mode :	HDMI 2 2560*1440 144Hz Horizontal Rotation 1.2m D-SUB+DVI+HDMI+Display+Audio+USB cable (715G8055)		
Test Engineer :	Lucky Mao		

Vertical

80.0 dBuV/m

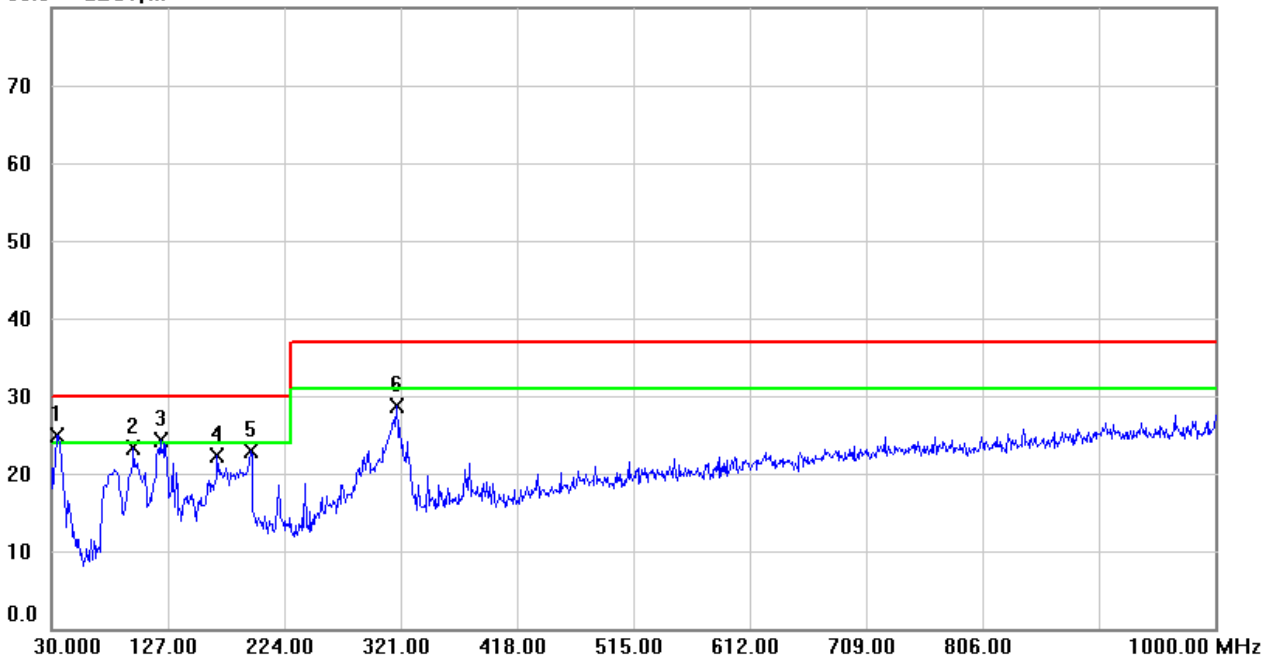

Horizontal

80.0 dBuV/m

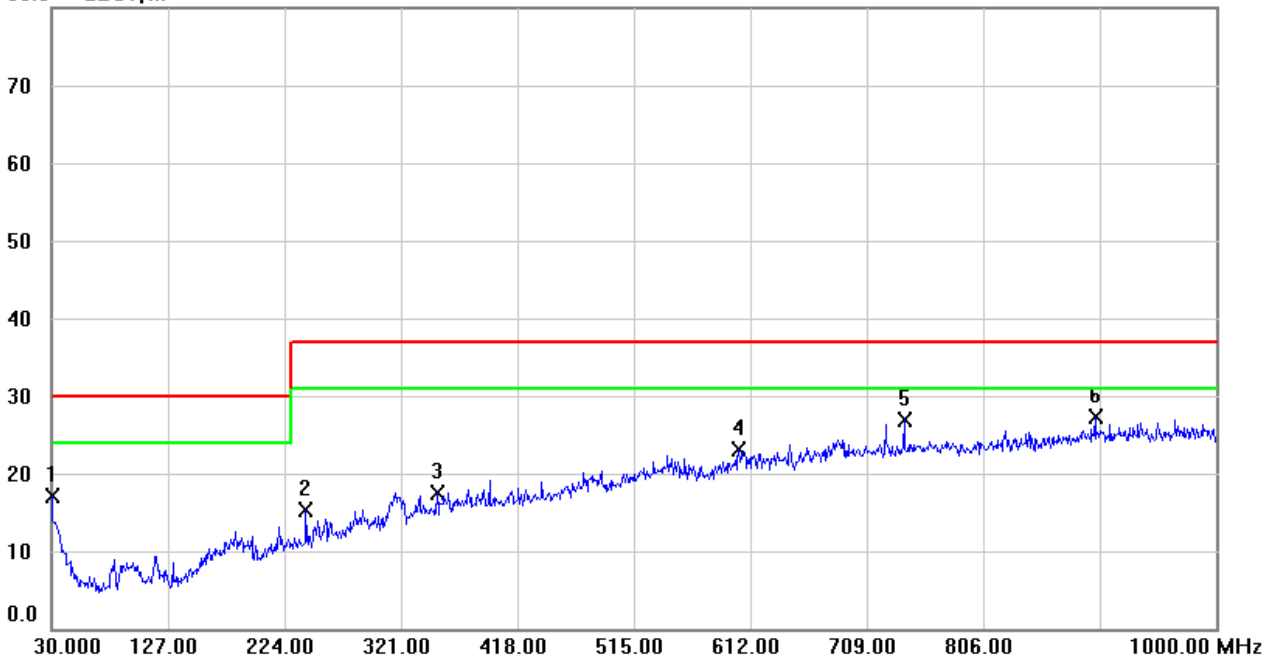

E.U.T :	LCD Monitor	Model Name :	238LM00009
Temperature :	25° C	Relative Humidity :	53%
Pressure :	1013 hPa	Test Voltage :	AC 230V/50Hz
Test Mode :	HDMI 2 2560*1440 144Hz Vertical Rotation 1.2m D-SUB+DVI+HDMI+Display+Audio+USB cable (715G8055)		
Test Engineer :	Lucky Mao		

Vertical

80.0 dBuV/m

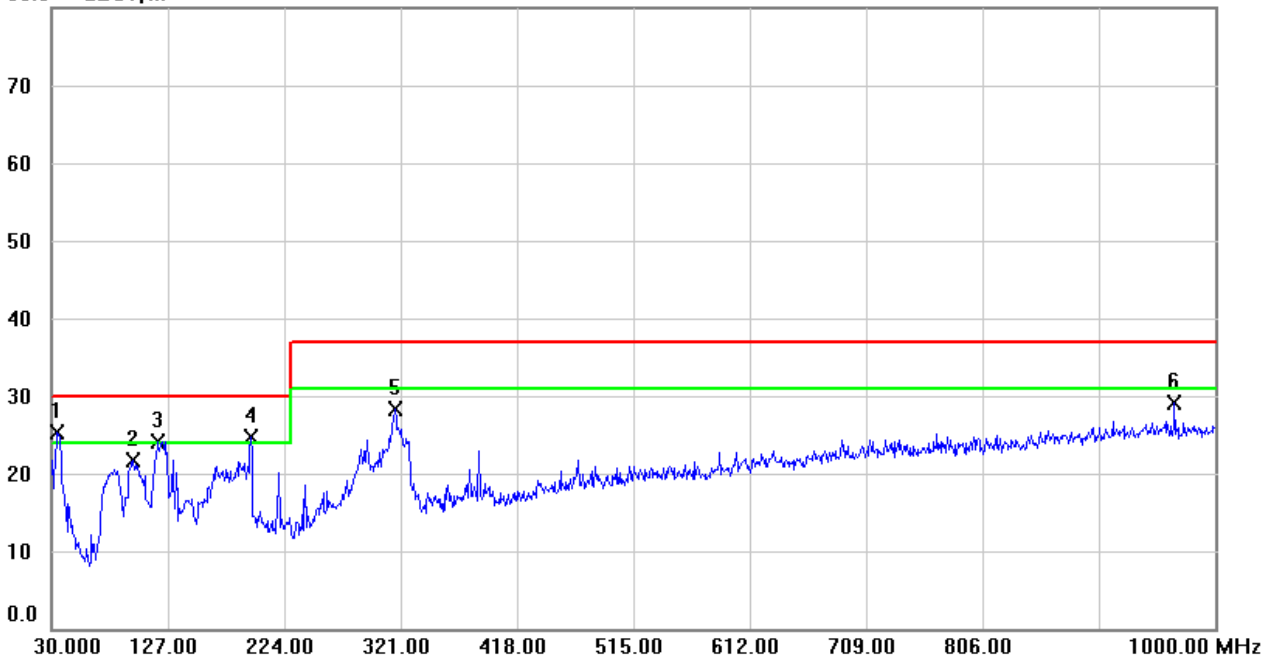

Horizontal

80.0 dBuV/m

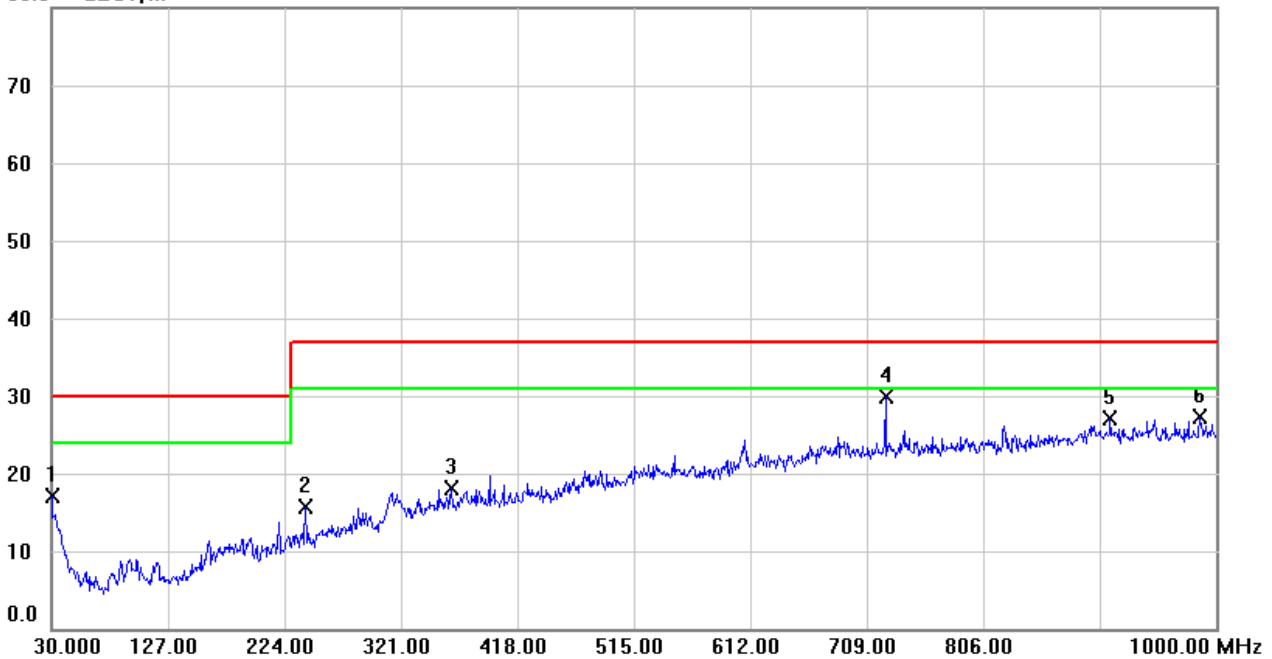

4.1.8 TEST RESULTS (ABOVE 1 GHZ)

E.U.T :	LCD Monitor	Model Name :	238LM00009
Temperature :	24° C	Relative Humidity :	60%
Pressure :	1013 hPa	Test Voltage :	AC 230V/50Hz
Test Mode :	Display 2560*1440 144Hz 1.8m Display+HDMI+Audio+USB cable (715G8083)	Polarization:	Vertical
Test Engineer :	Lucky Mao		

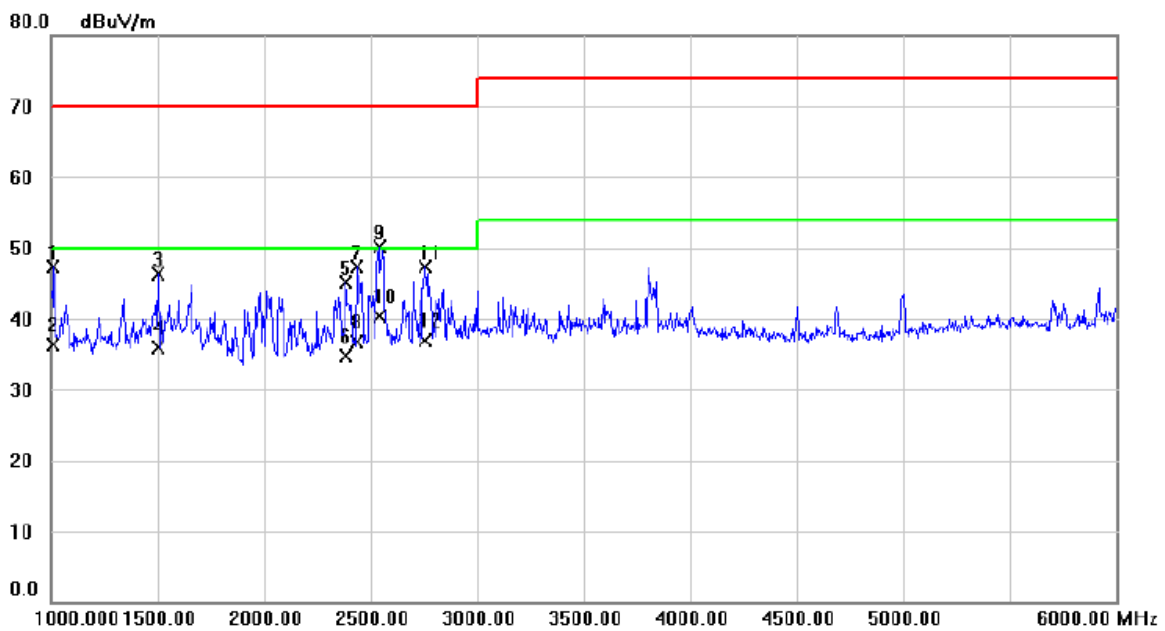

No.	Mk.	Freq. MHz	Reading Level dBuV	Correct Factor dB	Measure- ment dBuV/m	Limit dBuV/m	Margin dB	Detector	Comment
1		1012.500	50.48	-3.23	47.25	70.00	-22.75	peak	
2		1012.500	39.47	-3.23	36.24	50.00	-13.76	AVG	
3		1500.000	49.04	-2.76	46.28	70.00	-23.72	peak	
4		1500.000	38.74	-2.76	35.98	50.00	-14.02	AVG	
5		2382.500	46.51	-1.36	45.15	70.00	-24.85	peak	
6		2382.500	35.98	-1.36	34.62	50.00	-15.38	AVG	
7		2437.500	48.27	-0.98	47.29	70.00	-22.71	peak	
8		2437.500	37.75	-0.98	36.77	50.00	-13.23	AVG	
9		2542.500	50.43	-0.32	50.11	70.00	-19.89	peak	
10	*	2542.500	40.63	-0.32	40.31	50.00	-9.69	AVG	
11		2757.500	46.47	0.76	47.23	70.00	-22.77	peak	
12		2757.500	36.09	0.76	36.85	50.00	-13.15	AVG	

E.U.T :	LCD Monitor	Model Name :	238LM00009
Temperature :	24° C	Relative Humidity :	60%
Pressure :	1013 hPa	Test Voltage :	AC 230V/50Hz
Test Mode :	Display 2560*1440 144Hz 1.8m Display+HDMI+Audio+USB cable (715G8083)	Polarization:	Horizontal
Test Engineer :	Lucky Mao		

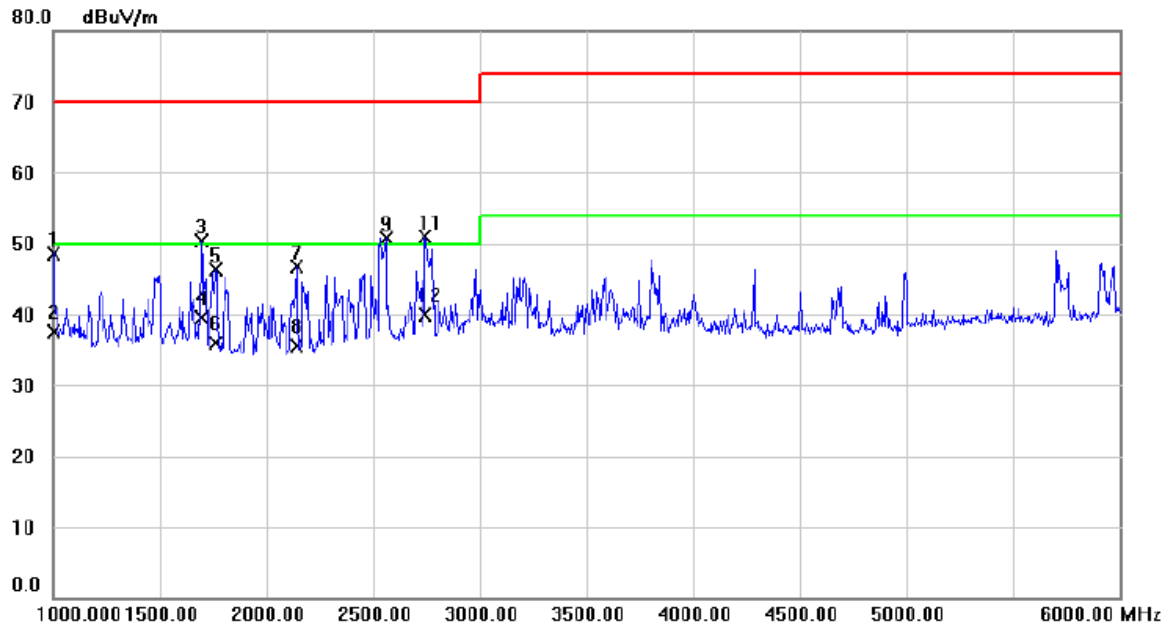

No.	Mk.	Freq. MHz	Reading Level dBuV	Correct Factor dB	Measure- ment dBuV/m	Limit dBuV/m	Margin dB	Detector	Comment
1		1000.000	51.84	-3.24	48.60	70.00	-21.40	peak	
2		1000.000	40.66	-3.24	37.42	50.00	-12.58	AVG	
3		1697.500	53.63	-3.27	50.36	70.00	-19.64	peak	
4		1697.500	42.81	-3.27	39.54	50.00	-10.46	AVG	
5		1762.500	49.70	-3.45	46.25	70.00	-23.75	peak	
6		1762.500	39.43	-3.45	35.98	50.00	-14.02	AVG	
7		2142.500	49.71	-3.05	46.66	70.00	-23.34	peak	
8		2142.500	38.48	-3.05	35.43	50.00	-14.57	AVG	
9		2560.000	50.97	-0.23	50.74	70.00	-19.26	peak	
10	*	2560.000	393.4	-0.23	393.21	50.00	343.21	AVG	
11		2745.000	50.15	0.70	50.85	70.00	-19.15	peak	
12		2745.000	39.14	0.70	39.84	50.00	-10.16	AVG	

E.U.T :	LCD Monitor	Model Name :	238LM00009
Temperature :	24° C	Relative Humidity :	60%
Pressure :	1013 hPa	Test Voltage :	AC 230V/50Hz
Test Mode :	HDMI 2560*1440 60Hz 1.8m Display+HDMI+Audio+USB cable (715G8083)	Polarization:	Vertical
Test Engineer :	Lucky Mao		

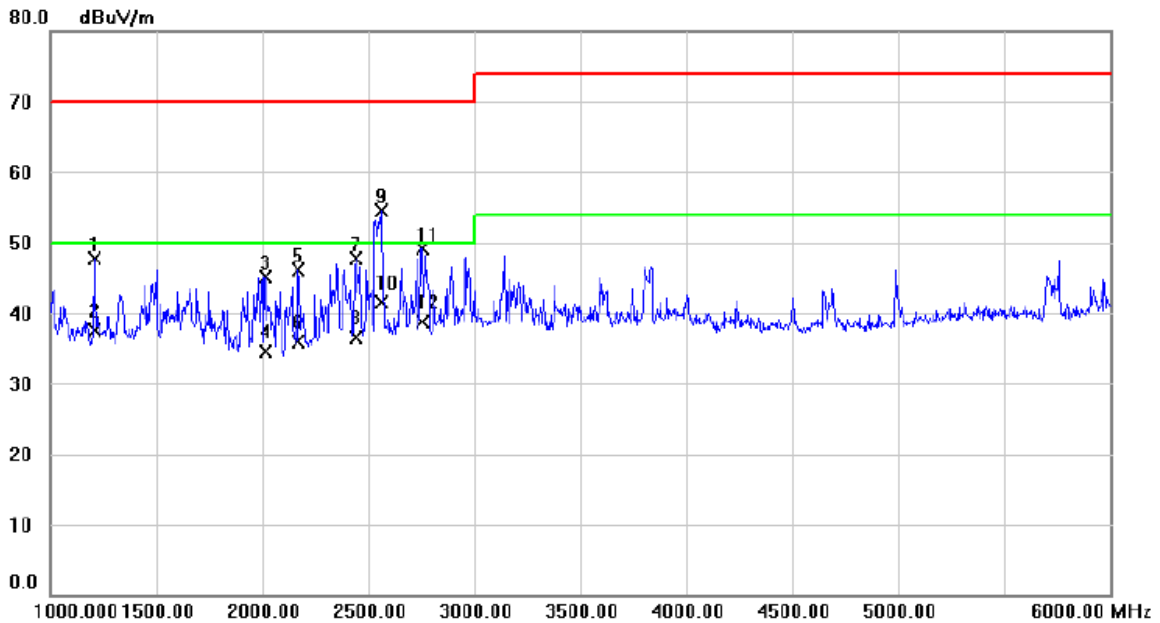

No.	Mk.	Freq. MHz	Reading Level dBuV	Correct Factor dB	Measure- ment dBuV/m	Limit dBuV/m	Margin dB	Detector	Comment
1		1207.500	50.69	-3.04	47.65	70.00	-22.35	peak	
2		1207.500	40.46	-3.04	37.42	50.00	-12.58	AVG	
3		2015.000	49.16	-3.96	45.20	70.00	-24.80	peak	
4		2015.000	38.53	-3.96	34.57	50.00	-15.43	AVG	
5		2172.500	48.87	-2.84	46.03	70.00	-23.97	peak	
6		2172.500	38.82	-2.84	35.98	50.00	-14.02	AVG	
7		2440.000	48.58	-0.96	47.62	70.00	-22.38	peak	
8		2440.000	37.44	-0.96	36.48	50.00	-13.52	AVG	
9		2562.500	54.63	-0.22	54.41	70.00	-15.59	peak	
10	*	2562.500	41.69	-0.22	41.47	50.00	-8.53	AVG	
11		2755.000	48.37	0.74	49.11	70.00	-20.89	peak	
12		2755.000	38.05	0.74	38.79	50.00	-11.21	AVG	

E.U.T :	LCD Monitor	Model Name :	238LM00009
Temperature :	24° C	Relative Humidity :	60%
Pressure :	1013 hPa	Test Voltage :	AC 230V/50Hz
Test Mode :	HDMI 2560*1440 60Hz 1.8m Display+HDMI+Audio+USB cable (715G8083)	Polarization:	Horizontal
Test Engineer :	Lucky Mao		

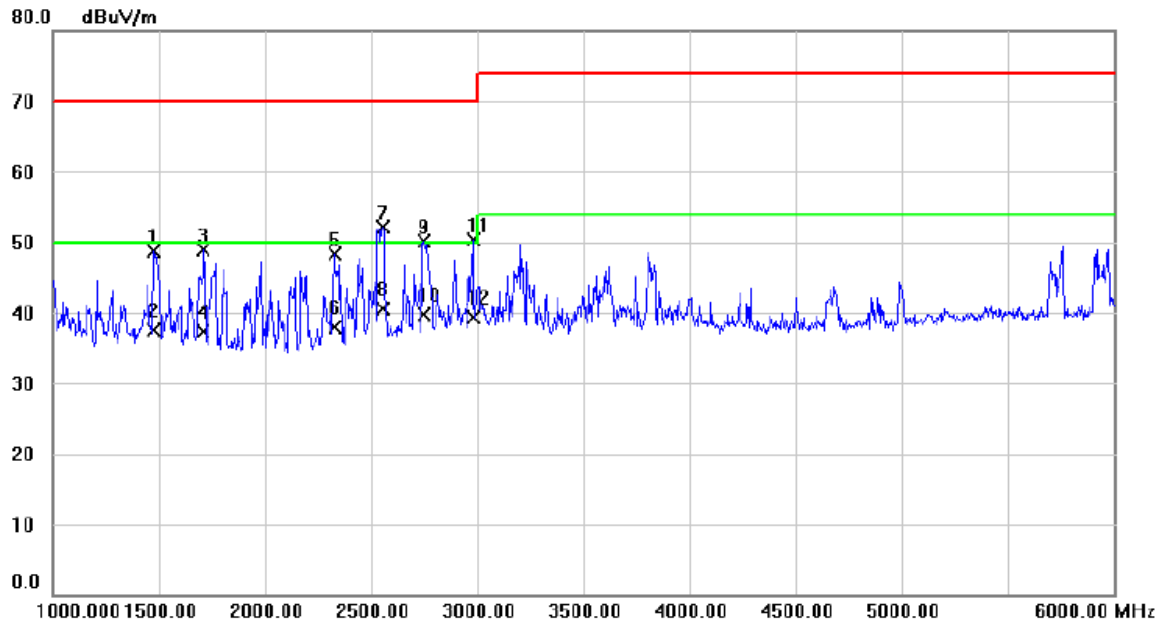

No.	Mk.	Freq. MHz	Reading Level dBuV	Correct Factor dB	Measure- ment dBuV/m	Limit dBuV/m	Margin dB	Detector	Comment
1		1477.500	51.41	-2.79	48.62	70.00	-21.38	peak	
2		1477.500	40.24	-2.79	37.45	50.00	-12.55	AVG	
3		1710.000	52.24	-3.30	48.94	70.00	-21.06	peak	
4		1710.000	40.55	-3.30	37.25	50.00	-12.75	AVG	
5		2327.500	49.97	-1.75	48.22	70.00	-21.78	peak	
6		2327.500	39.67	-1.75	37.92	50.00	-12.08	AVG	
7		2557.500	52.37	-0.24	52.13	70.00	-17.87	peak	
8	*	2557.500	40.76	-0.24	40.52	50.00	-9.48	AVG	
9		2750.000	49.46	0.72	50.18	70.00	-19.82	peak	
10		2750.000	38.99	0.72	39.71	50.00	-10.29	AVG	
11		2980.000	48.47	1.87	50.34	70.00	-19.66	peak	
12		2980.000	37.34	1.87	39.21	50.00	-10.79	AVG	

E.U.T :	LCD Monitor	Model Name :	238LM00009
Temperature :	24° C	Relative Humidity :	60%
Pressure :	1013 hPa	Test Voltage :	AC 230V/50Hz
Test Mode :	HDMI 1080P 1.8m (715G8083)	Polarization:	Vertical
Test Engineer :	Lucky Mao		

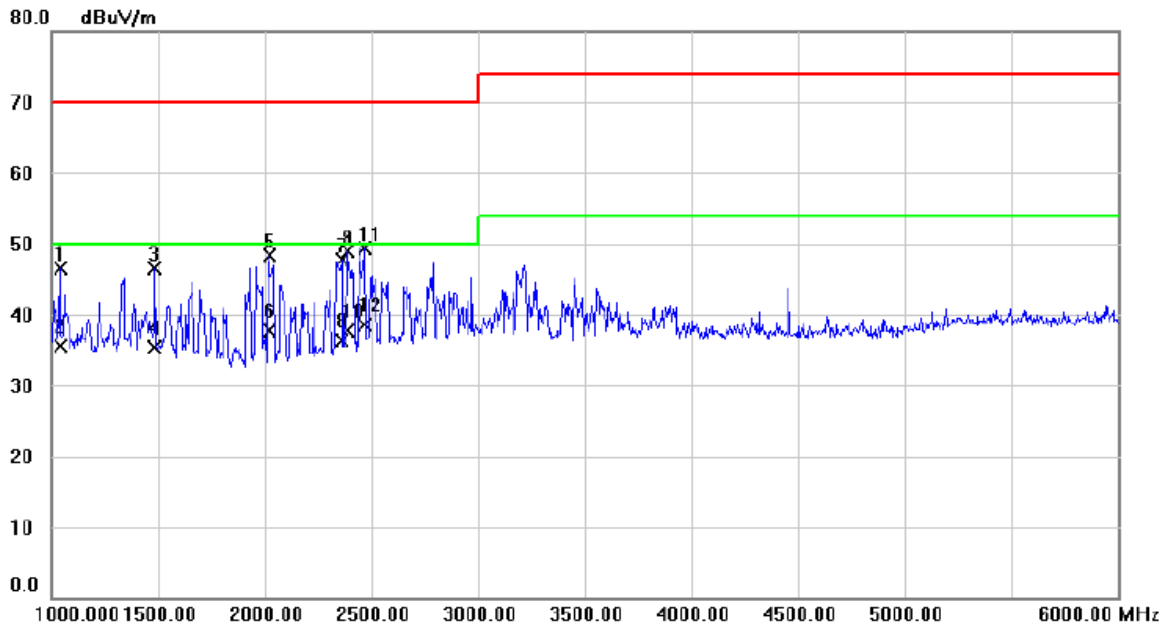

No.	Mk.	Freq. MHz	Reading Level dBuV	Correct Factor dB	Measure- ment dBuV/m	Limit dBuV/m	Margin dB	Detector	Comment
1		1040.000	49.62	-3.20	46.42	70.00	-23.58	peak	
2		1040.000	38.62	-3.20	35.42	50.00	-14.58	AVG	
3		1485.000	49.37	-2.78	46.59	70.00	-23.41	peak	
4		1485.000	38.05	-2.78	35.27	50.00	-14.73	AVG	
5		2020.000	52.30	-3.92	48.38	70.00	-21.62	peak	
6		2020.000	41.55	-3.92	37.63	50.00	-12.37	AVG	
7		2362.500	49.21	-1.50	47.71	70.00	-22.29	peak	
8		2362.500	37.79	-1.50	36.29	50.00	-13.71	AVG	
9		2387.500	50.25	-1.33	48.92	70.00	-21.08	peak	
10		2387.500	38.95	-1.33	37.62	50.00	-12.38	AVG	
11		2470.000	50.14	-0.75	49.39	70.00	-20.61	peak	
12	*	2470.000	39.24	-0.75	38.49	50.00	-11.51	AVG	

E.U.T :	LCD Monitor	Model Name :	238LM00009
Temperature :	24° C	Relative Humidity :	60%
Pressure :	1013 hPa	Test Voltage :	AC 230V/50Hz
Test Mode :	HDMI 1080P 1.8m (715G8083)	Polarization:	Horizontal
Test Engineer :	Lucky Mao		

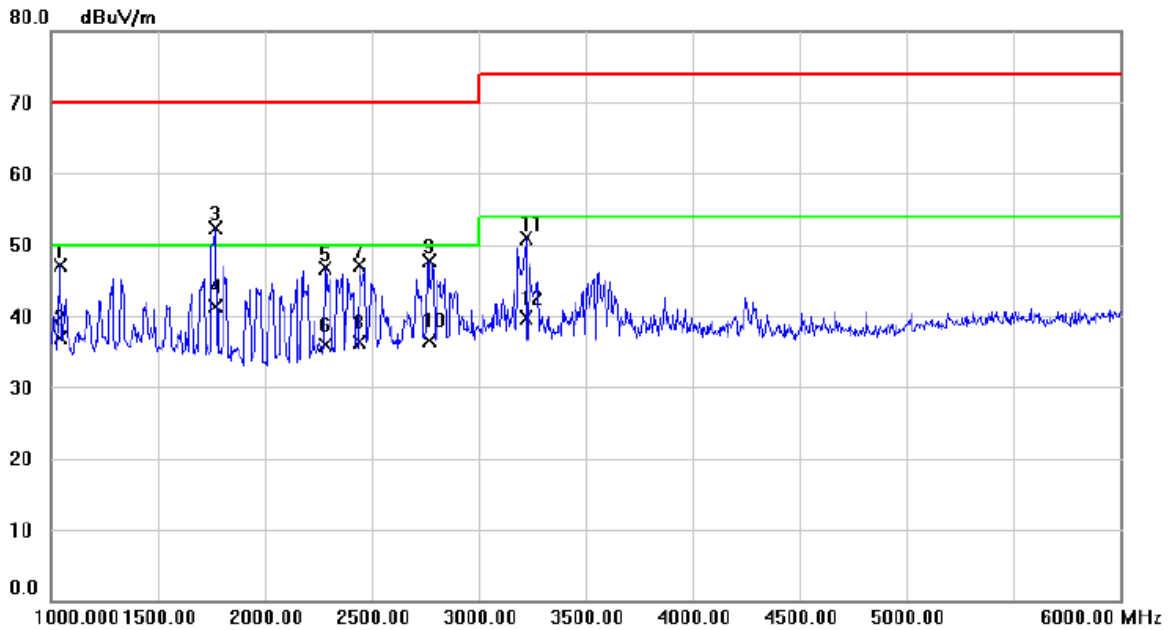

No.	Mk.	Freq. MHz	Reading Level dBuV	Correct Factor dB	Measure- ment dBuV/m	Limit dBuV/m	Margin dB	Detector	Comment
1		1040.000	50.26	-3.20	47.06	70.00	-22.94	peak	
2		1040.000	40.01	-3.20	36.81	50.00	-13.19	AVG	
3		1772.500	55.77	-3.46	52.31	70.00	-17.69	peak	
4	*	1772.500	44.79	-3.46	41.33	50.00	-8.67	AVG	
5		2282.500	48.71	-2.07	46.64	70.00	-23.36	peak	
6		2282.500	37.93	-2.07	35.86	50.00	-14.14	AVG	
7		2442.500	47.96	-0.94	47.02	70.00	-22.98	peak	
8		2442.500	37.22	-0.94	36.28	50.00	-13.72	AVG	
9		2767.500	46.96	0.81	47.77	70.00	-22.23	peak	
10		2767.500	35.66	0.81	36.47	50.00	-13.53	AVG	
11		3220.000	48.73	2.18	50.91	74.00	-23.09	peak	
12		3220.000	37.46	2.18	39.64	54.00	-14.36	AVG	

E.U.T :	LCD Monitor	Model Name :	238LM00009
Temperature :	24° C	Relative Humidity :	60%
Pressure :	1013 hPa	Test Voltage :	AC 230V/50Hz
Test Mode :	HDMI 2560*1440 60Hz 1.5m Display+HDMI+Audio+USB cable (715G8083)	Polarization:	Vertical
Test Engineer :	Lucky Mao		

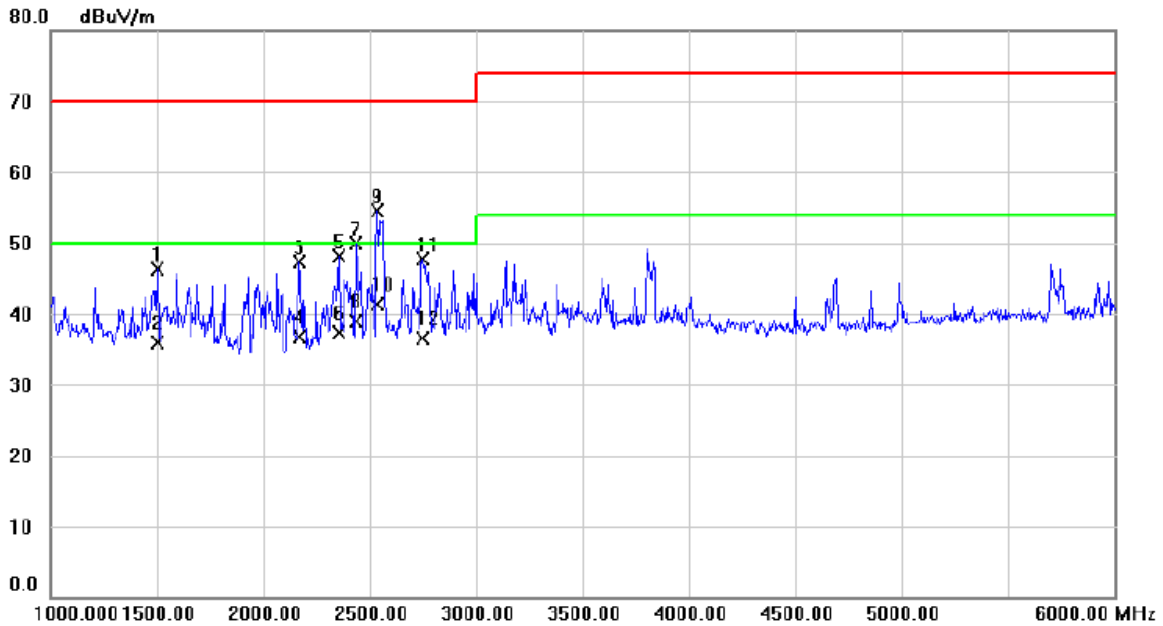

No.	Mk.	Freq. MHz	Reading Level dBuV	Correct Factor dB	Measure- ment dBuV/m	Limit dBuV/m	Margin dB	Detector	Comment
1		1500.000	49.01	-2.76	46.25	70.00	-23.75	peak	
2		1500.000	38.76	-2.76	36.00	50.00	-14.00	AVG	
3		2172.500	50.19	-2.84	47.35	70.00	-22.65	peak	
4		2172.500	39.58	-2.84	36.74	50.00	-13.26	AVG	
5		2357.500	49.66	-1.54	48.12	70.00	-21.88	peak	
6		2357.500	38.75	-1.54	37.21	50.00	-12.79	AVG	
7		2437.500	50.97	-0.98	49.99	70.00	-20.01	peak	
8		2437.500	39.88	-0.98	38.90	50.00	-11.10	AVG	
9		2537.500	54.79	-0.34	54.45	70.00	-15.55	peak	
10	*	2537.500	41.72	-0.34	41.38	50.00	-8.62	AVG	
11		2750.000	46.92	0.72	47.64	70.00	-22.36	peak	
12		2750.000	35.77	0.72	36.49	50.00	-13.51	AVG	

E.U.T :	LCD Monitor	Model Name :	238LM00009
Temperature :	24° C	Relative Humidity :	60%
Pressure :	1013 hPa	Test Voltage :	AC 230V/50Hz
Test Mode :	HDMI 2560*1440 60Hz 1.5m Display+HDMI+Audio+USB cable (715G8083)	Polarization:	Horizontal
Test Engineer :	Lucky Mao		

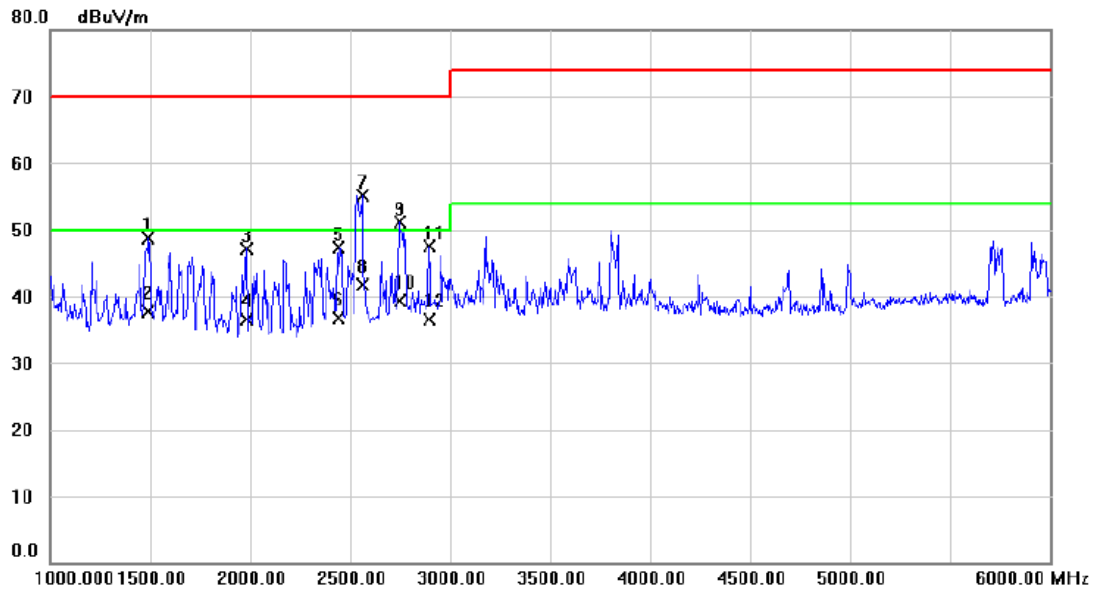

No.	Mk.	Freq. MHz	Reading Level dBuV	Correct Factor dB	Measure- ment dBuV/m	Limit dBuV/m	Margin dB	Detector	Comment
1		1490.000	51.46	-2.77	48.69	70.00	-21.31	peak	
2		1490.000	40.42	-2.77	37.65	50.00	-12.35	AVG	
3		1980.000	51.04	-4.00	47.04	70.00	-22.96	peak	
4		1980.000	40.41	-4.00	36.41	50.00	-13.59	AVG	
5		2440.000	48.19	-0.96	47.23	70.00	-22.77	peak	
6		2440.000	37.67	-0.96	36.71	50.00	-13.29	AVG	
7		2560.000	55.35	-0.23	55.12	70.00	-14.88	peak	
8	*	2560.000	41.91	-0.23	41.68	50.00	-8.32	AVG	
9		2747.500	50.40	0.71	51.11	70.00	-18.89	peak	
10		2747.500	38.67	0.71	39.38	50.00	-10.62	AVG	
11		2897.500	46.00	1.45	47.45	70.00	-22.55	peak	
12		2897.500	35.03	1.45	36.48	50.00	-13.52	AVG	

E.U.T :	LCD Monitor	Model Name :	238LM00009
Temperature :	24° C	Relative Humidity :	60%
Pressure :	1013 hPa	Test Voltage :	AC 230V/50Hz
Test Mode :	HDMI 2560*1440 60Hz 1.2m Display+HDMI+Audio+USB cable (715G8083)	Polarization:	Vertical
Test Engineer :	Lucky Mao		

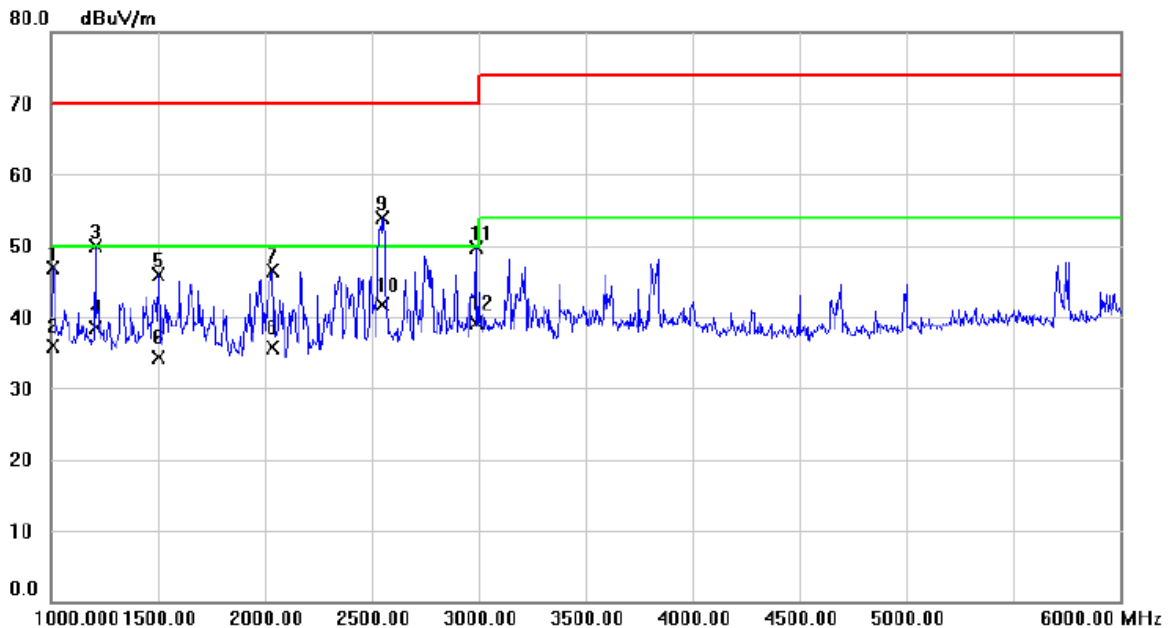

No.	Mk.	Freq. MHz	Reading Level dBuV	Correct Factor dB	Measure- ment dBuV/m	Limit dBuV/m	Margin dB	Detector	Comment
1		1010.000	50.06	-3.23	46.83	70.00	-23.17	peak	
2		1010.000	39.15	-3.23	35.92	50.00	-14.08	AVG	
3		1207.500	52.90	-3.04	49.86	70.00	-20.14	peak	
4		1207.500	41.46	-3.04	38.42	50.00	-11.58	AVG	
5		1500.000	48.64	-2.76	45.88	70.00	-24.12	peak	
6		1500.000	36.97	-2.76	34.21	50.00	-15.79	AVG	
7		2037.500	50.26	-3.80	46.46	70.00	-23.54	peak	
8		2037.500	39.52	-3.80	35.72	50.00	-14.28	AVG	
9		2552.500	54.15	-0.27	53.88	70.00	-16.12	peak	
10	*	2552.500	42.05	-0.27	41.78	50.00	-8.22	AVG	
11		2987.500	47.70	1.91	49.61	70.00	-20.39	peak	
12		2987.500	37.29	1.91	39.20	50.00	-10.80	AVG	

E.U.T :	LCD Monitor	Model Name :	238LM00009
Temperature :	24° C	Relative Humidity :	60%
Pressure :	1013 hPa	Test Voltage :	AC 230V/50Hz
Test Mode :	HDMI 2560*1440 60Hz 1.2m Display+HDMI+Audio+USB cable (715G8083)	Polarization:	Horizontal
Test Engineer :	Lucky Mao		

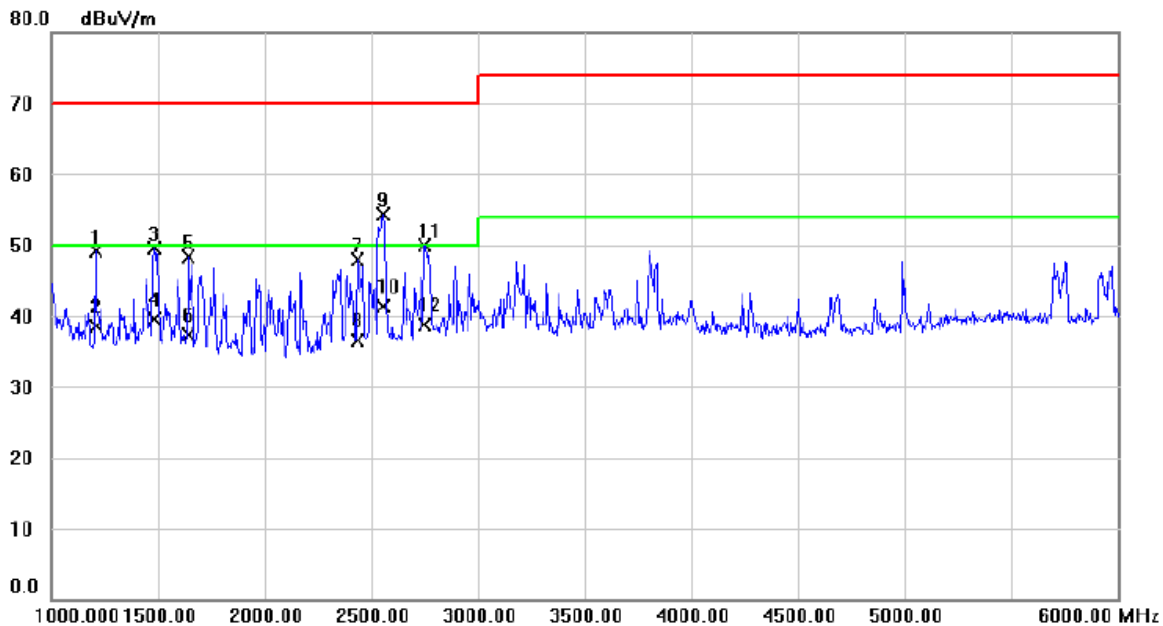

No.	Mk.	Freq. MHz	Reading Level dBuV	Correct Factor dB	Measure- ment dBuV/m	Limit dBuV/m	Margin dB	Detector	Comment
1		1207.500	52.08	-3.04	49.04	70.00	-20.96	peak	
2		1207.500	41.53	-3.04	38.49	50.00	-11.51	AVG	
3		1480.000	52.24	-2.78	49.46	70.00	-20.54	peak	
4		1480.000	42.24	-2.78	39.46	50.00	-10.54	AVG	
5		1645.000	51.44	-3.14	48.30	70.00	-21.70	peak	
6		1645.000	40.39	-3.14	37.25	50.00	-12.75	AVG	
7		2437.500	48.89	-0.98	47.91	70.00	-22.09	peak	
8		2437.500	37.40	-0.98	36.42	50.00	-13.58	AVG	
9		2555.000	54.61	-0.26	54.35	70.00	-15.65	peak	
10	*	2555.000	41.64	-0.26	41.38	50.00	-8.62	AVG	
11		2747.500	49.22	0.71	49.93	70.00	-20.07	peak	
12		2747.500	38.08	0.71	38.79	50.00	-11.21	AVG	

E.U.T :	LCD Monitor	Model Name :	238LM00009
Temperature :	24° C	Relative Humidity :	60%
Pressure :	1013 hPa	Test Voltage :	AC 230V/50Hz
Test Mode :	Display 2560*1440 144Hz 1.8m D-SUB+DVI+HDMI+Display+Audio+ USB cable (715G8055)	Polarization:	Vertical
Test Engineer :	Lucky Mao		

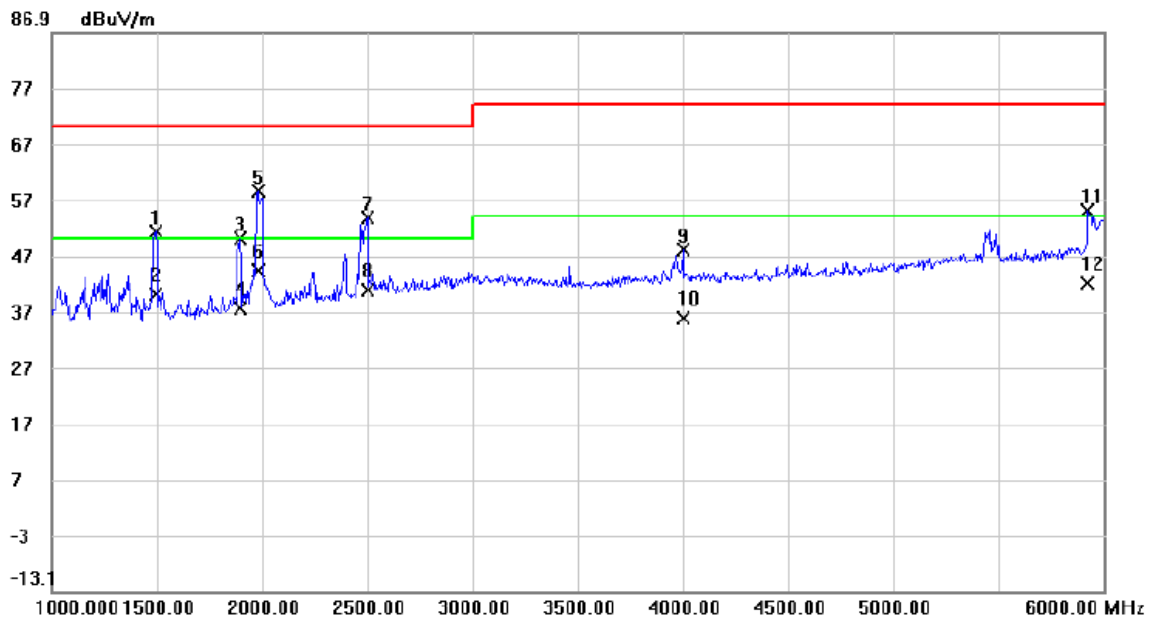

No.	Mk.	Freq.	Reading Level	Correct Factor	Measurement	Limit	Margin	Antenna Height	Table Degree	
		MHz	dBuV	dB	dBuV/m	dBuV/m	dB	cm	degree	Comment
1		1495.000	58.11	-6.89	51.22	70.00	-18.78			peak
2		1495.000	46.99	-6.89	40.10	50.00	-9.90			AVG
3		1895.000	53.97	-3.85	50.12	70.00	-19.88			peak
4		1895.000	41.45	-3.85	37.60	50.00	-12.40			AVG
5		1980.000	61.78	-3.19	58.59	70.00	-11.41			peak
6	*	1980.000	47.39	-3.19	44.20	50.00	-5.80			AVG
7		2500.000	54.98	-1.22	53.76	70.00	-16.24			peak
8		2500.000	42.02	-1.22	40.80	50.00	-9.20			AVG
9		4000.000	45.26	2.80	48.06	74.00	-25.94			peak
10		4000.000	33.10	2.80	35.90	54.00	-18.10			AVG
11		5925.000	46.84	8.27	55.11	74.00	-18.89			peak
12		5925.000	33.83	8.27	42.10	54.00	-11.90			AVG

E.U.T :	LCD Monitor	Model Name :	238LM00009
Temperature :	24° C	Relative Humidity :	60%
Pressure :	1013 hPa	Test Voltage :	AC 230V/50Hz
Test Mode :	Display 2560*1440 144Hz 1.8m D-SUB+DVI+HDMI+Display+Audio+ USB cable (715G8055)	Polarization:	Horizontal
Test Engineer :	Lucky Mao		

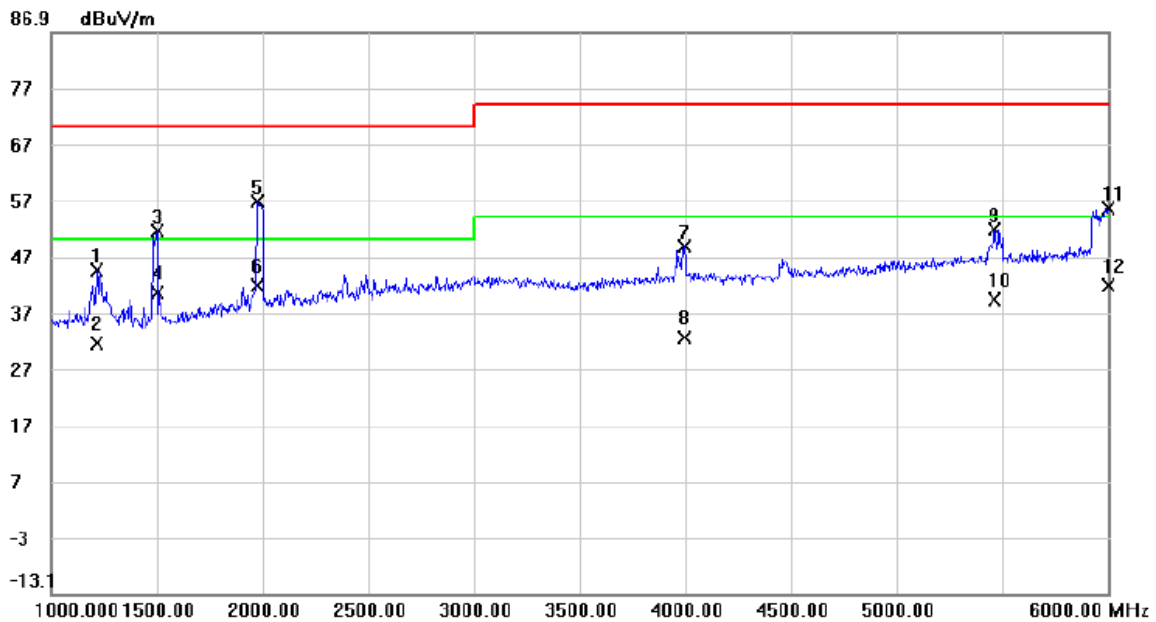

No.	Mk.	Freq.	Reading Level	Correct Factor	Measurement	Limit	Margin	Antenna Height	Table Degree	
		MHz	dBuV	dB	dBuV/m	dBuV/m	dB	cm	degree	Comment
1		1215.000	52.17	-7.62	44.55	70.00	-25.45			peak
2		1215.000	39.12	-7.62	31.50	50.00	-18.50			AVG
3		1500.000	58.37	-6.87	51.50	70.00	-18.50			peak
4		1500.000	47.37	-6.87	40.50	50.00	-9.50			AVG
5		1975.000	59.90	-3.24	56.66	70.00	-13.34			peak
6	*	1975.000	45.14	-3.24	41.90	50.00	-8.10			AVG
7		3995.000	46.11	2.79	48.90	74.00	-25.10			peak
8		3995.000	29.81	2.79	32.60	54.00	-21.40			AVG
9		5465.000	44.82	6.90	51.72	74.00	-22.28			peak
10		5465.000	32.50	6.90	39.40	54.00	-14.60			AVG
11		6000.000	47.09	8.50	55.59	74.00	-18.41			peak
12		6000.000	33.40	8.50	41.90	54.00	-12.10			AVG

E.U.T :	LCD Monitor	Model Name :	238LM00009
Temperature :	24° C	Relative Humidity :	60%
Pressure :	1013 hPa	Test Voltage :	AC 230V/50Hz
Test Mode :	HDMI 2 2560*1440 144Hz 1.8m D-SUB+DVI+HDMI+Display+Audio +USB cable (715G8055)	Polarization:	Vertical
Test Engineer :	Lucky Mao		

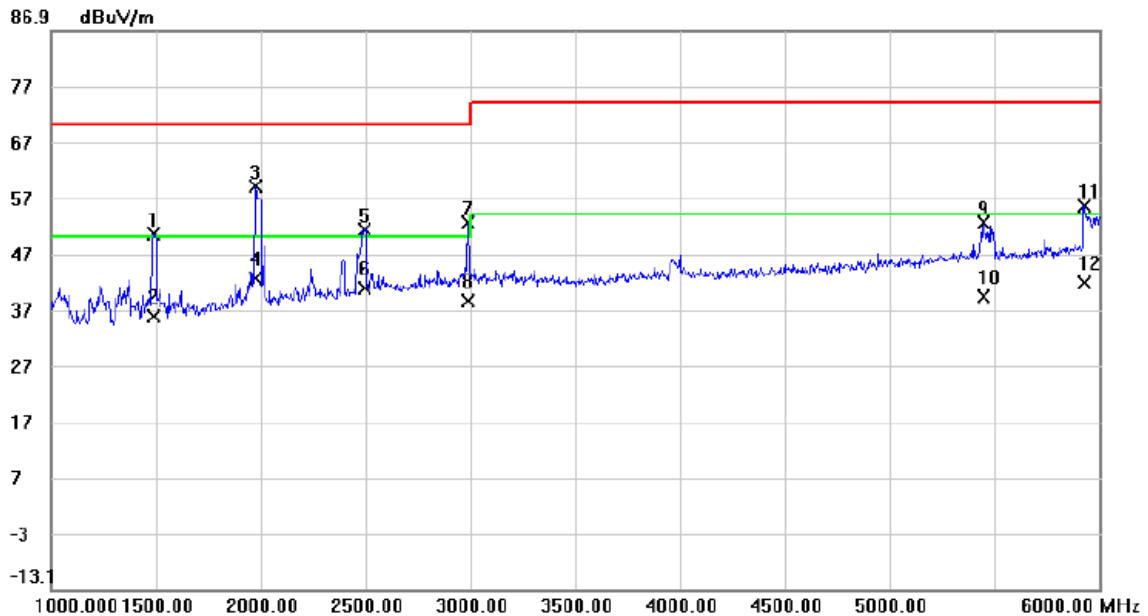

No.	Mk.	Freq. MHz	Reading Level dBuV	Correct Factor dB	Measure- ment dBuV/m	Limit dBuV/m	Margin dB	Antenna Height cm	Table Degree	Detector	Comment
1		1490.000	57.51	-6.89	50.62	70.00	-19.38			peak	
2		1490.000	42.79	-6.89	35.90	50.00	-14.10			AVG	
3		1975.000	62.31	-3.24	59.07	70.00	-10.93			peak	
4	*	1975.000	45.74	-3.24	42.50	50.00	-7.50			AVG	
5		2495.000	52.59	-1.24	51.35	70.00	-18.65			peak	
6		2495.000	41.94	-1.24	40.70	50.00	-9.30			AVG	
7		2990.000	51.29	1.16	52.45	70.00	-17.55			peak	
8		2990.000	37.44	1.16	38.60	50.00	-11.40			AVG	
9		5450.000	45.69	6.85	52.54	74.00	-21.46			peak	
10		5450.000	32.35	6.85	39.20	54.00	-14.80			AVG	
11		5930.000	47.33	8.29	55.62	74.00	-18.38			peak	
12		5930.000	33.61	8.29	41.90	54.00	-12.10			AVG	

E.U.T :	LCD Monitor	Model Name :	238LM00009
Temperature :	24° C	Relative Humidity :	60%
Pressure :	1013 hPa	Test Voltage :	AC 230V/50Hz
Test Mode :	HDMI 2 2560*1440 144Hz 1.8m D-SUB+DVI+HDMI+Display+Audio +USB cable (715G8055)	Polarization:	Horizontal
Test Engineer :	Lucky Mao		

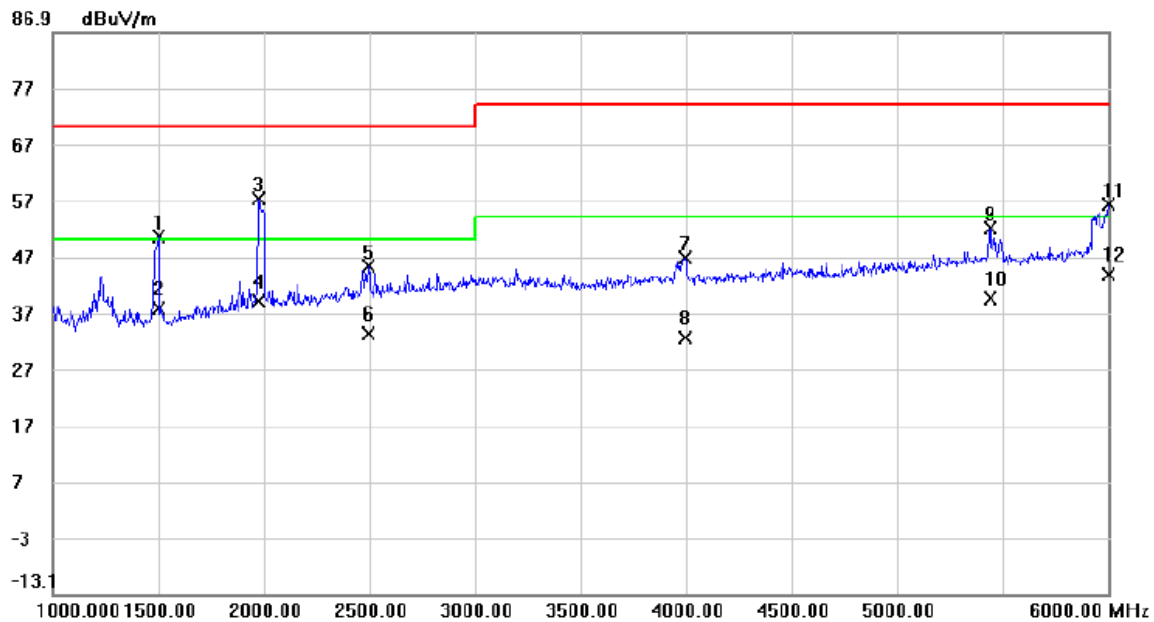

No.	Mk.	Freq.	Reading Level	Correct Factor	Measurement	Limit	Margin	Antenna Height	Table Degree	
		MHz	dBuV	dB	dBuV/m	dBuV/m	dB	cm	degree	Comment
1		1500.000	57.45	-6.87	50.58	70.00	-19.42			peak
2		1500.000	44.77	-6.87	37.90	50.00	-12.10			AVG
3		1975.000	60.40	-3.24	57.16	70.00	-12.84			peak
4		1975.000	42.36	-3.24	39.12	50.00	-10.88			AVG
5		2495.000	46.44	-1.24	45.20	70.00	-24.80			peak
6		2495.000	34.64	-1.24	33.40	50.00	-16.60			AVG
7		3995.000	43.96	2.79	46.75	74.00	-27.25			peak
8		3995.000	29.81	2.79	32.60	54.00	-21.40			AVG
9		5440.000	45.27	6.82	52.09	74.00	-21.91			peak
10		5440.000	32.68	6.82	39.50	54.00	-14.50			AVG
11		6000.000	47.68	8.50	56.18	74.00	-17.82			peak
12	*	6000.000	35.20	8.50	43.70	54.00	-10.30			AVG

E.U.T :	LCD Monitor	Model Name :	238LM00009
Temperature :	24° C	Relative Humidity :	60%
Pressure :	1013 hPa	Test Voltage :	AC 230V/50Hz
Test Mode :	HDMI 2 1080P 1.8m (715G8055)	Polarization:	Vertical
Test Engineer :	Lucky Mao		

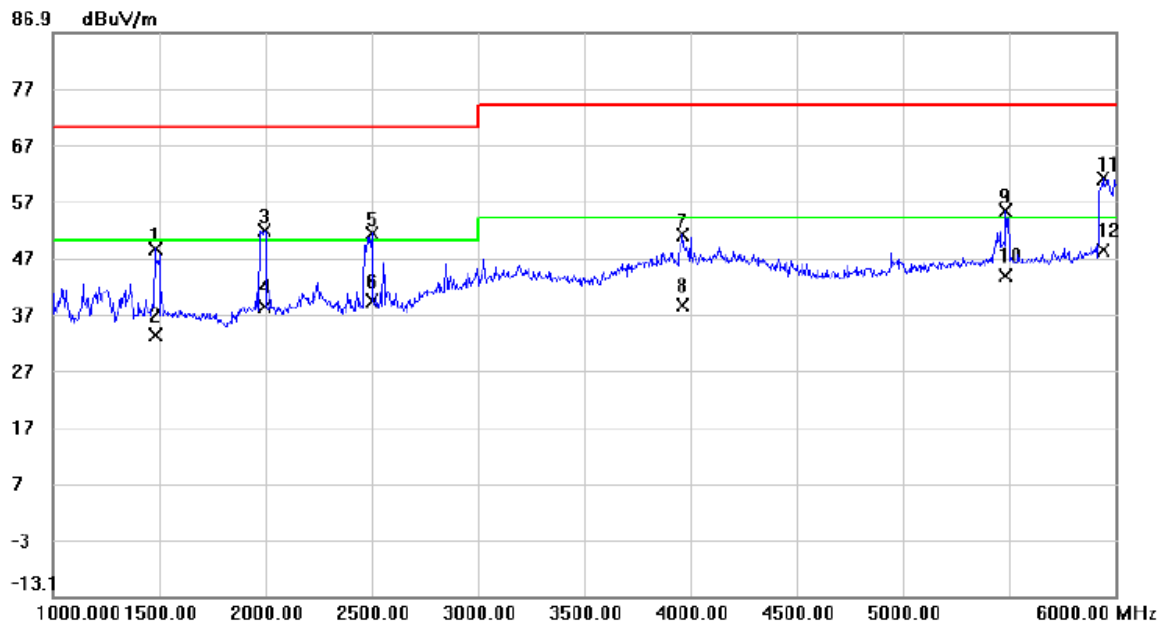

No.	Mk.	Freq.	Reading Level	Correct Factor	Measurement	Limit	Margin	Antenna Height	Table Degree	
		MHz	dBuV	dB	dBuV/m	dBuV/m	dB	cm	degree	Comment
1		1480.000	55.43	-6.92	48.51	70.00	-21.49			peak
2		1480.000	40.12	-6.92	33.20	50.00	-16.80			AVG
3		1995.000	54.85	-3.09	51.76	70.00	-18.24			peak
4		1995.000	41.49	-3.09	38.40	50.00	-11.60			AVG
5		2500.000	52.42	-1.22	51.20	70.00	-18.80			peak
6		2500.000	40.42	-1.22	39.20	50.00	-10.80			AVG
7		3965.000	48.26	2.69	50.95	74.00	-23.05			peak
8		3965.000	35.91	2.69	38.60	54.00	-15.40			AVG
9		5485.000	48.21	6.96	55.17	74.00	-18.83			peak
10		5485.000	36.74	6.96	43.70	54.00	-10.30			AVG
11		5940.000	52.74	8.32	61.06	74.00	-12.94			peak
12	*	5940.000	40.08	8.32	48.40	54.00	-5.60			AVG

E.U.T :	LCD Monitor	Model Name :	238LM00009
Temperature :	24° C	Relative Humidity :	60%
Pressure :	1013 hPa	Test Voltage :	AC 230V/50Hz
Test Mode :	HDMI 2 1080P 1.8m (715G8055)	Polarization:	Horizontal
Test Engineer :	Lucky Mao		

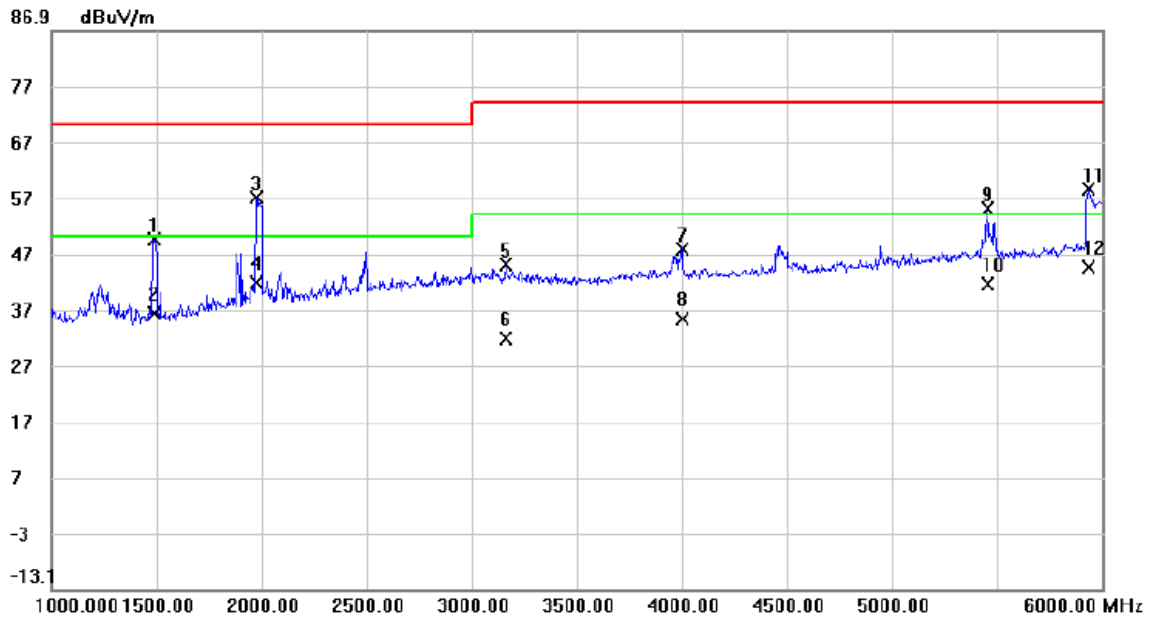

No.	Mk.	Freq.	Reading Level	Correct Factor	Measurement	Limit	Margin	Antenna Height	Table Degree	
		MHz	dBuV	dB	dBuV/m	dBuV/m	dB	cm	degree	Comment
1		1490.000	56.33	-6.89	49.44	70.00	-20.56			peak
2		1490.000	43.09	-6.89	36.20	50.00	-13.80			AVG
3		1975.000	60.31	-3.24	57.07	70.00	-12.93			peak
4	*	1975.000	45.13	-3.24	41.89	50.00	-8.11			AVG
5		3160.000	43.88	1.19	45.07	74.00	-28.93			peak
6		3160.000	30.61	1.19	31.80	54.00	-22.20			AVG
7		4000.000	45.10	2.80	47.90	74.00	-26.10			peak
8		4000.000	32.50	2.80	35.30	54.00	-18.70			AVG
9		5455.000	48.16	6.86	55.02	74.00	-18.98			peak
10		5455.000	34.64	6.86	41.50	54.00	-12.50			AVG
11		5935.000	50.29	8.30	58.59	74.00	-15.41			peak
12		5935.000	36.30	8.30	44.60	54.00	-9.40			AVG

E.U.T :	LCD Monitor	Model Name :	238LM00009
Temperature :	24° C	Relative Humidity :	60%
Pressure :	1013 hPa	Test Voltage :	AC 230V/50Hz
Test Mode :	HDMI 2 2560*1440 144Hz 1.5m D-SUB+DVI+HDMI+Display+Audio +USB cable (715G8055)	Polarization:	Vertical
Test Engineer :	Lucky Mao		

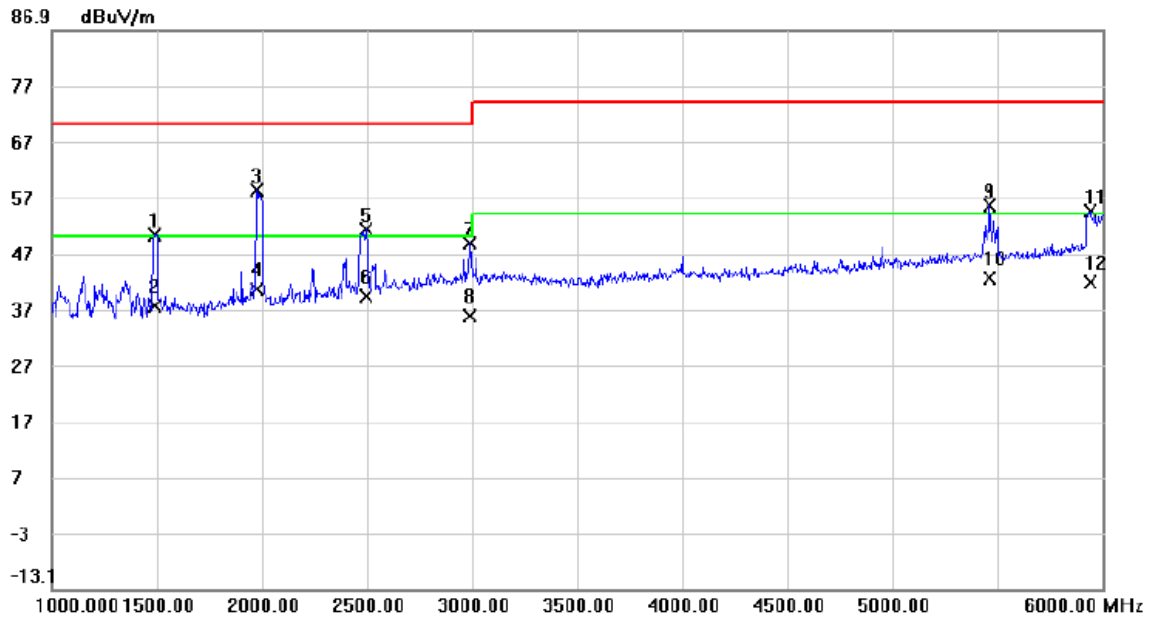

No.	Mk.	Freq.	Reading Level	Correct Factor	Measurement	Limit	Margin	Antenna Height	Table Degree	
		MHz	dBuV	dB	dBuV/m	dBuV/m	dB	cm	degree	Comment
1		1490.000	57.20	-6.89	50.31	70.00	-19.69			peak
2		1490.000	44.49	-6.89	37.60	50.00	-12.40			AVG
3		1975.000	61.56	-3.24	58.32	70.00	-11.68			peak
4	*	1975.000	43.68	-3.24	40.44	50.00	-9.56			AVG
5		2495.000	52.59	-1.24	51.35	70.00	-18.65			peak
6		2495.000	40.64	-1.24	39.40	50.00	-10.60			AVG
7		2990.000	47.69	1.16	48.85	70.00	-21.15			peak
8		2990.000	34.54	1.16	35.70	50.00	-14.30			AVG
9		5465.000	48.69	6.90	55.59	74.00	-18.41			peak
10		5465.000	35.70	6.90	42.60	54.00	-11.40			AVG
11		5940.000	46.19	8.32	54.51	74.00	-19.49			peak
12		5940.000	33.58	8.32	41.90	54.00	-12.10			AVG

E.U.T :	LCD Monitor	Model Name :	238LM00009
Temperature :	24° C	Relative Humidity :	60%
Pressure :	1013 hPa	Test Voltage :	AC 230V/50Hz
Test Mode :	HDMI 2 2560*1440 144Hz 1.5m D-SUB+DVI+HDMI+Display+Audio +USB cable (715G8055)	Polarization:	Horizontal
Test Engineer :	Lucky Mao		

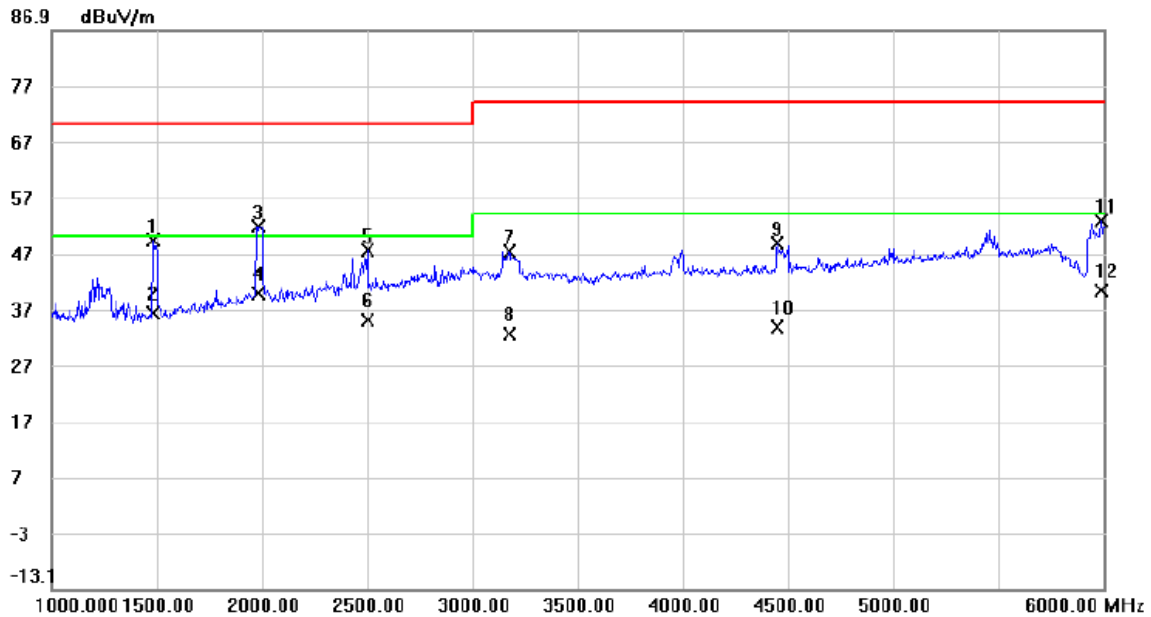

No.	Mk.	Freq.	Reading Level	Correct Factor	Measurement	Limit	Margin	Antenna Height	Table Degree	
		MHz	dBuV	dB	dBuV/m	dBuV/m	dB	cm	degree	Comment
1		1485.000	56.28	-6.92	49.36	70.00	-20.64			peak
2		1485.000	43.12	-6.92	36.20	50.00	-13.80			AVG
3		1985.000	54.96	-3.16	51.80	70.00	-18.20			peak
4	*	1985.000	42.96	-3.16	39.80	50.00	-10.20			AVG
5		2500.000	48.68	-1.22	47.46	70.00	-22.54			peak
6		2500.000	36.32	-1.22	35.10	50.00	-14.90			AVG
7		3175.000	46.10	1.18	47.28	74.00	-26.72			peak
8		3175.000	31.32	1.18	32.50	54.00	-21.50			AVG
9		4450.000	45.37	3.37	48.74	74.00	-25.26			peak
10		4450.000	30.53	3.37	33.90	54.00	-20.10			AVG
11		5990.000	44.21	8.47	52.68	74.00	-21.32			peak
12		5990.000	31.73	8.47	40.20	54.00	-13.80			AVG

E.U.T :	LCD Monitor	Model Name :	238LM00009
Temperature :	24° C	Relative Humidity :	60%
Pressure :	1013 hPa	Test Voltage :	AC 230V/50Hz
Test Mode :	HDMI 2 2560*1440 144Hz 1.2m D-SUB+DVI+HDMI+Display+Audio +USB cable (715G8055)	Polarization:	Vertical
Test Engineer :	Lucky Mao		

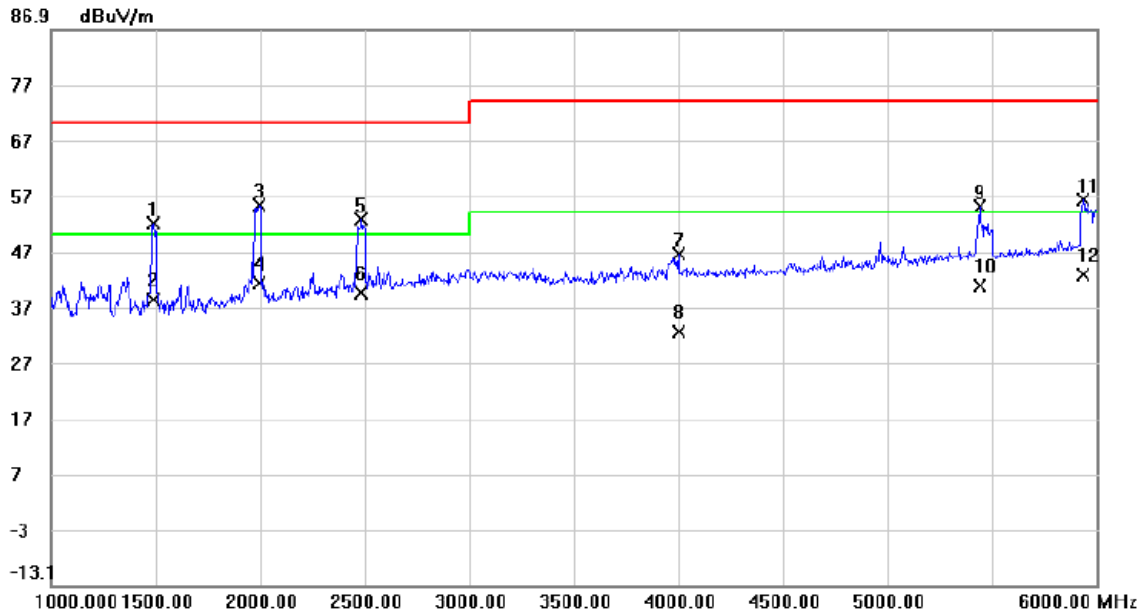

No.	Mk.	Freq. MHz	Reading Level dBuV	Correct Factor dB	Measure- ment dBuV/m	Limit dBuV/m	Margin dB	Antenna Height cm	Table Degree	Comment
1		1490.000	58.81	-6.89	51.92	70.00	-18.08			peak
2		1490.000	45.29	-6.89	38.40	50.00	-11.60			AVG
3		1995.000	58.35	-3.09	55.26	70.00	-14.74			peak
4	*	1995.000	44.32	-3.09	41.23	50.00	-8.77			AVG
5		2485.000	54.07	-1.27	52.80	70.00	-17.20			peak
6		2485.000	40.87	-1.27	39.60	50.00	-10.40			AVG
7		4000.000	43.77	2.80	46.57	74.00	-27.43			peak
8		4000.000	29.70	2.80	32.50	54.00	-21.50			AVG
9		5440.000	48.16	6.82	54.98	74.00	-19.02			peak
10		5440.000	33.88	6.82	40.70	54.00	-13.30			AVG
11		5935.000	47.98	8.30	56.28	74.00	-17.72			peak
12		5935.000	34.60	8.30	42.90	54.00	-11.10			AVG

E.U.T :	LCD Monitor	Model Name :	238LM00009
Temperature :	24° C	Relative Humidity :	60%
Pressure :	1013 hPa	Test Voltage :	AC 230V/50Hz
Test Mode :	HDMI 2 2560*1440 144Hz 1.2m D-SUB+DVI+HDMI+Display+Audio +USB cable (715G8055)	Polarization:	Horizontal
Test Engineer :	Lucky Mao		

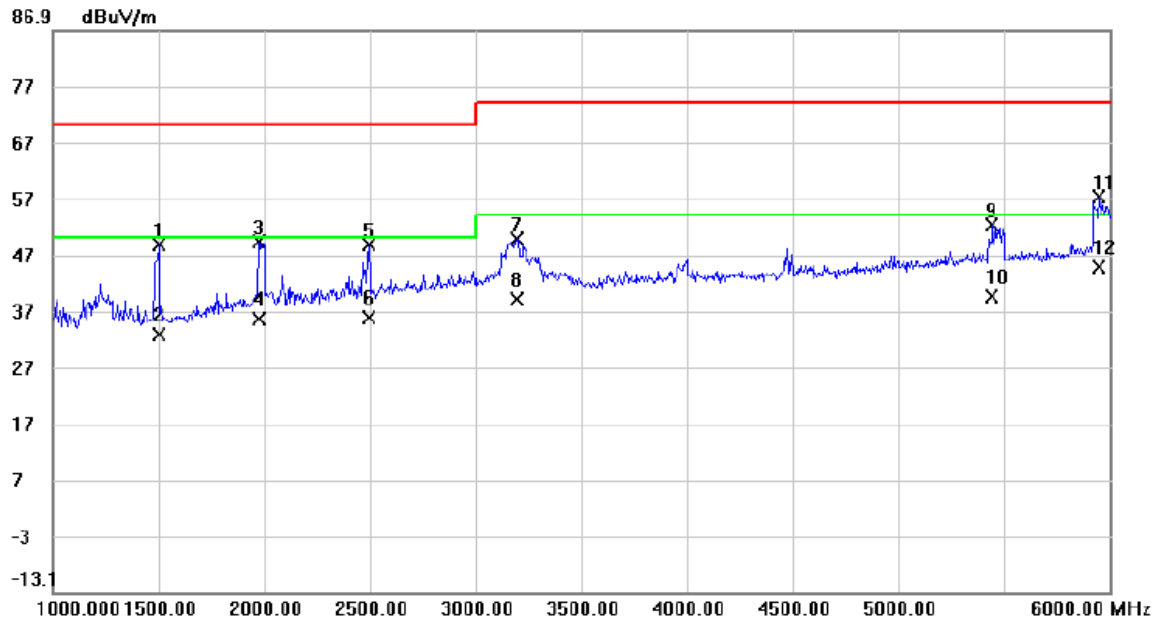

No.	Mk.	Freq.	Reading Level	Correct Factor	Measurement	Limit	Margin	Antenna Height	Table Degree	
		MHz	dBuV	dB	dBuV/m	dBuV/m	dB	cm	degree	Comment
1		1500.000	55.55	-6.87	48.68	70.00	-21.32			peak
2		1500.000	39.76	-6.87	32.89	50.00	-17.11			AVG
3		1975.000	52.51	-3.24	49.27	70.00	-20.73			peak
4		1975.000	38.84	-3.24	35.60	50.00	-14.40			AVG
5		2495.000	49.97	-1.24	48.73	70.00	-21.27			peak
6		2495.000	36.94	-1.24	35.70	50.00	-14.30			AVG
7		3195.000	48.62	1.18	49.80	74.00	-24.20			peak
8		3195.000	37.96	1.18	39.14	54.00	-14.86			AVG
9		5445.000	45.40	6.83	52.23	74.00	-21.77			peak
10		5445.000	32.77	6.83	39.60	54.00	-14.40			AVG
11		5950.000	48.88	8.35	57.23	74.00	-16.77			peak
12	*	5950.000	36.35	8.35	44.70	54.00	-9.30			AVG

4.2 CONDUCTED EMISSION MEASUREMENT AT AC MAINS POWER PORTS

4.2.1 LIMITS

Requirements for conducted emissions from AC mains power ports of Class A equipment

Table clause	Frequency Range Hz	Coupling Device	Detector Type / bandwidth	Class A Limits (dB(μV))
A8.1	0.15 - 0.5	AMN	Quasi Peak / 9 kHz	79
	0.5 - 30			73
A8.2	0.15 - 0.5	AMN	Average / 9 kHz	66
	0.5 - 30			60

Requirements for conducted emissions from AC mains power ports of Class B equipment

Table clause	Frequency Range MHz	Coupling Device	Detector Type / bandwidth	Class B Limits (dB(μV))
A9.1	0.15 - 0.5	AMN	Quasi Peak / 9 kHz	66-56
	0.5 - 5			56
	5 - 30			60
A9.2	0.15 - 0.5	AMN	Average / 9 kHz	56-46
	0.5 - 5			46
	5 - 30			50

NOTE:

- (1) The test result calculated as following:
 Measurement Value = Reading Level + Correct Factor
 Correct Factor = Insertion Loss + Cable Loss + Attenuator Factor(if use)
 Margin Level = Measurement Value – Limit Value

4.2.2 MEASUREMENT INSTRUMENTS LIST

Item	Kind of Equipment	Manufacturer	Type No.	Serial No.	Calibrated until
1	Artificial-Mains Network	SCHWARZBEC K	NSLK 8127	8127685	Nov. 20, 2016
2	LISN	R&S	ENV216	100526	Mar. 27, 2017
3	Test Cable	N/A	RG400 12m	N/A	Mar. 10, 2017
4	EMI Test Receiver	R&S	ESR3	101862	Nov. 20, 2016
5	50Ω Terminator	SHX	TF2-3G-A	08122901	Mar. 27, 2017
6	Measurement Software	Farad	EZ-EMC Ver.NB-03A1-01	N/A	N/A

Remark: "N/A" denotes no model name, no serial no. or no calibration specified.
 All calibration period of equipment list is one year.

4.2.3 TEST PROCEDURE

- a. The EUT was placed 0.8 meters from the horizontal ground plane with EUT being connected to the power mains through a line impedance stabilization network (LISN). All other support equipments powered from additional LISN(s). The LISN provide 50 Ohm/ 50uH of coupling impedance for the measuring instrument.
- b. Interconnecting cables that hang closer than 40 cm to the ground plane shall be folded back and forth in the center forming a bundle 30 to 40 cm long.
- c. I/O cables that are not connected to a peripheral shall be bundled in the center. The end of the cable may be terminated, if required, using the correct terminating impedance. The overall length shall not exceed 1 m.
- d. LISN at least 80 cm from nearest part of EUT chassis.
- e. For the actual test configuration, please refer to the related Item –EUT Test Photos.

4.2.4 DEVIATION FROM TEST STANDARD

No deviation

4.2.5 TEST SETUP

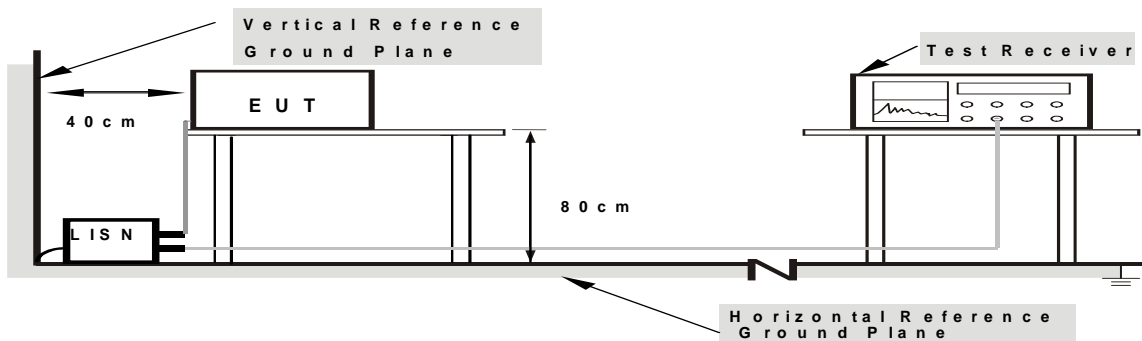

Note: 1. Support units were connected to second LISN.
 2. Both of LISNs (AMN) are 80 cm from EUT and at least 80 cm from other units and other metal planes

4.2.6 TEST RESULTS

E.U.T :	LCD Monitor	Model Name :	238LM00009
Temperature :	25° C	Relative Humidity :	53%
Pressure :	1013 hPa	Test Voltage :	AC 230V/50Hz
Test Mode :	Display 2560*1440 144Hz 1.8m Display+HDMI+Audio+USB cable (715G8083)	Phase:	Line
Test Engineer :	Lucky Mao		

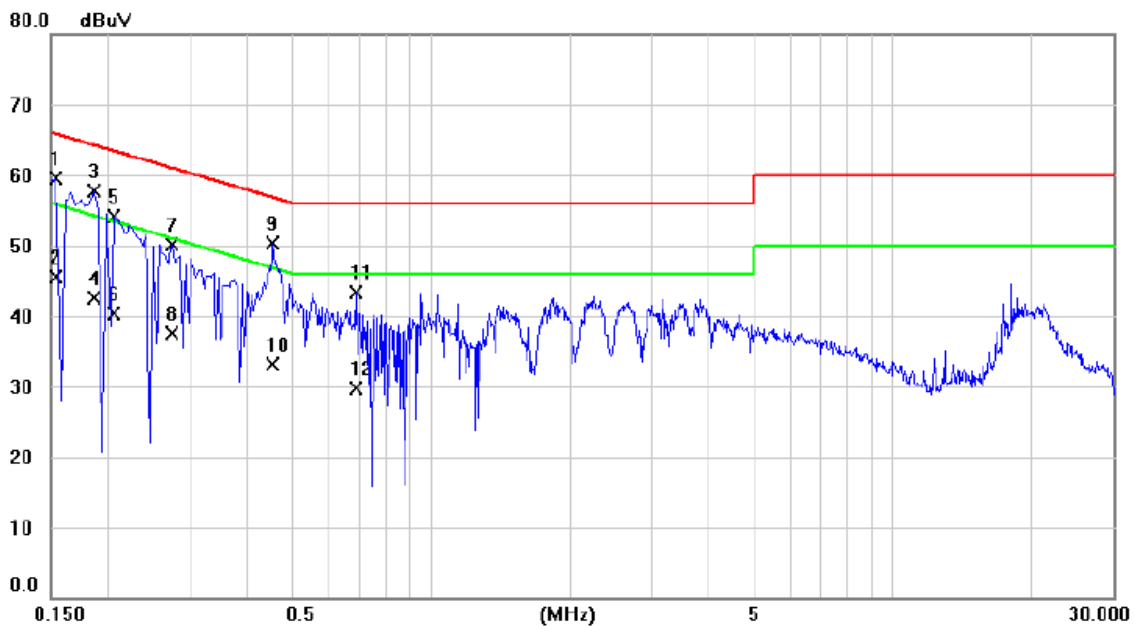

No.	Mk.	Freq. MHz	Reading Level dBuV	Correct Factor dB	Measure- ment dBuV	Limit dBuV	Margin dB	Detector	Comment
1	*	0.1540	50.00	9.52	59.52	65.78	-6.26	QP	
2		0.1540	35.90	9.52	45.42	55.78	-10.36	AVG	
3		0.1860	48.19	9.53	57.72	64.21	-6.49	QP	
4		0.1860	32.90	9.53	42.43	54.21	-11.78	AVG	
5		0.2060	44.60	9.53	54.13	63.37	-9.24	QP	
6		0.2060	30.80	9.53	40.33	53.37	-13.04	AVG	
7		0.2740	40.60	9.53	50.13	61.00	-10.87	QP	
8		0.2740	27.90	9.53	37.43	51.00	-13.57	AVG	
9		0.4540	40.77	9.59	50.36	56.80	-6.44	QP	
10		0.4540	23.60	9.59	33.19	46.80	-13.61	AVG	
11		0.6860	33.73	9.65	43.38	56.00	-12.62	QP	
12		0.6860	20.10	9.65	29.75	46.00	-16.25	AVG	

E.U.T :	LCD Monitor	Model Name :	238LM00009
Temperature :	25° C	Relative Humidity :	53%
Pressure :	1013 hPa	Test Voltage :	AC 230V/50Hz
Test Mode :	Display 2560*1440 144Hz 1.8m Display+HDMI+Audio+USB cable (715G8083)	Phase:	Neutral
Test Engineer :	Lucky Mao		

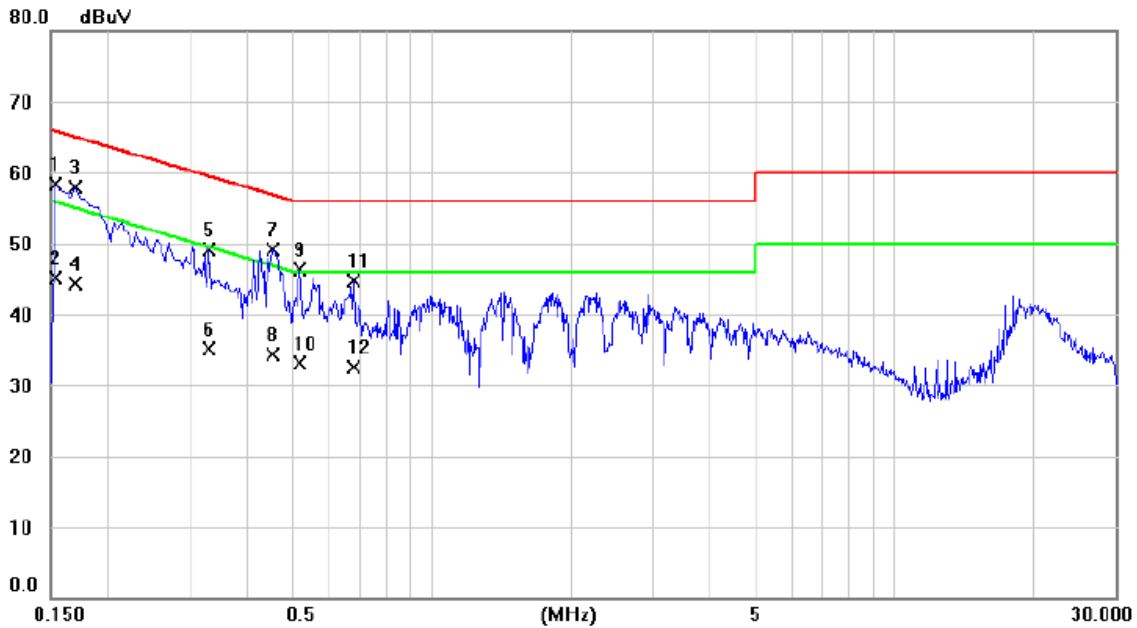

No.	Mk.	Freq. MHz	Reading Level dBuV	Correct Factor dB	Measure- ment dBuV	Limit dBuV	Margin dB	Detector	Comment
1		0.1540	48.79	9.50	58.29	65.78	-7.49	QP	
2		0.1540	35.60	9.50	45.10	55.78	-10.68	AVG	
3	*	0.1700	48.49	9.42	57.91	64.96	-7.05	QP	
4		0.1700	34.90	9.42	44.32	54.96	-10.64	AVG	
5		0.3300	39.59	9.53	49.12	59.45	-10.33	QP	
6		0.3300	25.60	9.53	35.13	49.45	-14.32	AVG	
7		0.4540	39.59	9.44	49.03	56.80	-7.77	QP	
8		0.4540	24.90	9.44	34.34	46.80	-12.46	AVG	
9		0.5180	36.90	9.44	46.34	56.00	-9.66	QP	
10		0.5180	23.70	9.44	33.14	46.00	-12.86	AVG	
11		0.6780	35.18	9.45	44.63	56.00	-11.37	QP	
12		0.6780	23.10	9.45	32.55	46.00	-13.45	AVG	

E.U.T :	LCD Monitor	Model Name :	238LM00009
Temperature :	25° C	Relative Humidity :	53%
Pressure :	1013 hPa	Test Voltage :	AC 230V/50Hz
Test Mode :	HDMI 2560*1440 60Hz 1.8m Display+HDMI+Audio+USB cable (715G8083)	Phase:	Line
Test Engineer :	Lucky Mao		

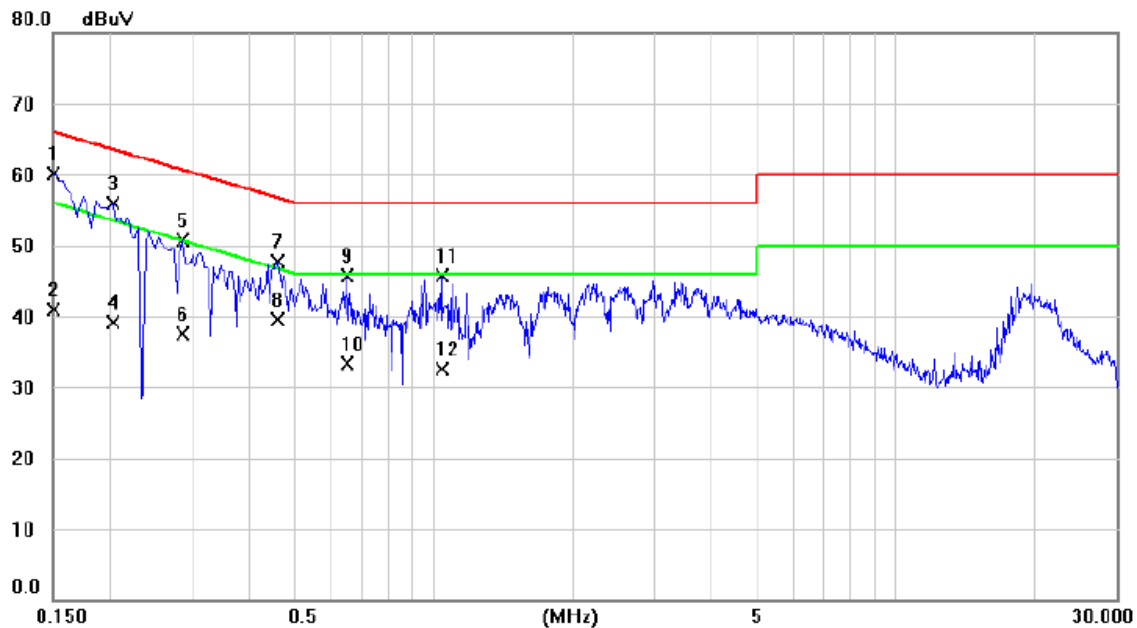

No.	Mk.	Freq. MHz	Reading Level dBuV	Correct Factor dB	Measurement dBuV	Limit dBuV	Margin dB	Detector	Comment
1	*	0.1500	50.67	9.52	60.19	66.00	-5.81	QP	
2		0.1500	31.30	9.52	40.82	56.00	-15.18	AVG	
3		0.2020	46.46	9.53	55.99	63.53	-7.54	QP	
4		0.2020	29.50	9.53	39.03	53.53	-14.50	AVG	
5		0.2860	41.16	9.53	50.69	60.64	-9.95	QP	
6		0.2860	27.90	9.53	37.43	50.64	-13.21	AVG	
7		0.4580	38.05	9.60	47.65	56.73	-9.08	QP	
8		0.4580	30.00	9.60	39.60	46.73	-7.13	AVG	
9		0.6500	36.07	9.64	45.71	56.00	-10.29	QP	
10		0.6500	23.70	9.64	33.34	46.00	-12.66	AVG	
11		1.0420	36.03	9.76	45.79	56.00	-10.21	QP	
12		1.0420	22.80	9.76	32.56	46.00	-13.44	AVG	

E.U.T :	LCD Monitor	Model Name :	238LM00009
Temperature :	25° C	Relative Humidity :	53%
Pressure :	1013 hPa	Test Voltage :	AC 230V/50Hz
Test Mode :	HDMI 2560*1440 60Hz 1.8m Display+HDMI+Audio+USB cable (715G8083)	Phase:	Neutral
Test Engineer :	Lucky Mao		

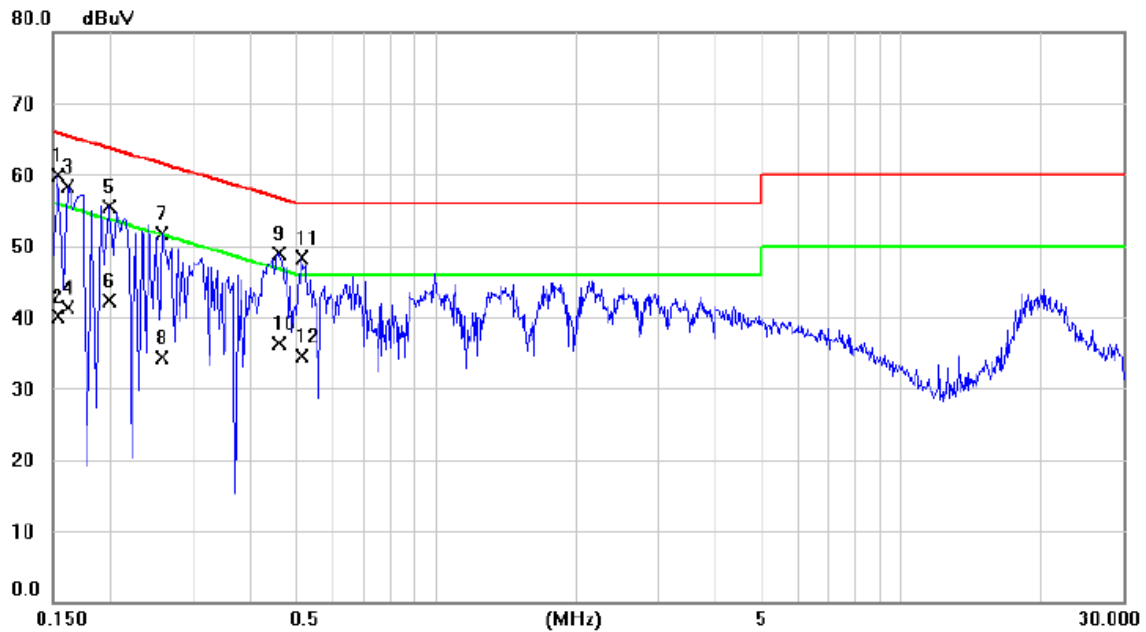

No.	Mk.	Freq. MHz	Reading Level dBuV	Correct Factor dB	Measure- ment dBuV	Limit dBuV	Margin dB	Detector	Comment
1	*	0.1540	50.40	9.50	59.90	65.78	-5.88	QP	
2		0.1540	30.70	9.50	40.20	55.78	-15.58	AVG	
3		0.1620	48.76	9.46	58.22	65.36	-7.14	QP	
4		0.1620	31.90	9.46	41.36	55.36	-14.00	AVG	
5		0.1980	45.98	9.52	55.50	63.69	-8.19	QP	
6		0.1980	32.70	9.52	42.22	53.69	-11.47	AVG	
7		0.2580	42.26	9.53	51.79	61.50	-9.71	QP	
8		0.2580	24.70	9.53	34.23	51.50	-17.27	AVG	
9		0.4580	39.37	9.44	48.81	56.73	-7.92	QP	
10		0.4580	26.90	9.44	36.34	46.73	-10.39	AVG	
11		0.5140	38.87	9.44	48.31	56.00	-7.69	QP	
12		0.5140	25.10	9.44	34.54	46.00	-11.46	AVG	

E.U.T :	LCD Monitor	Model Name :	238LM00009
Temperature :	25° C	Relative Humidity :	53%
Pressure :	1013 hPa	Test Voltage :	AC 230V/50Hz
Test Mode :	HDMI 1080P 1.8m (715G8083)	Phase:	Line
Test Engineer :	Lucky Mao		

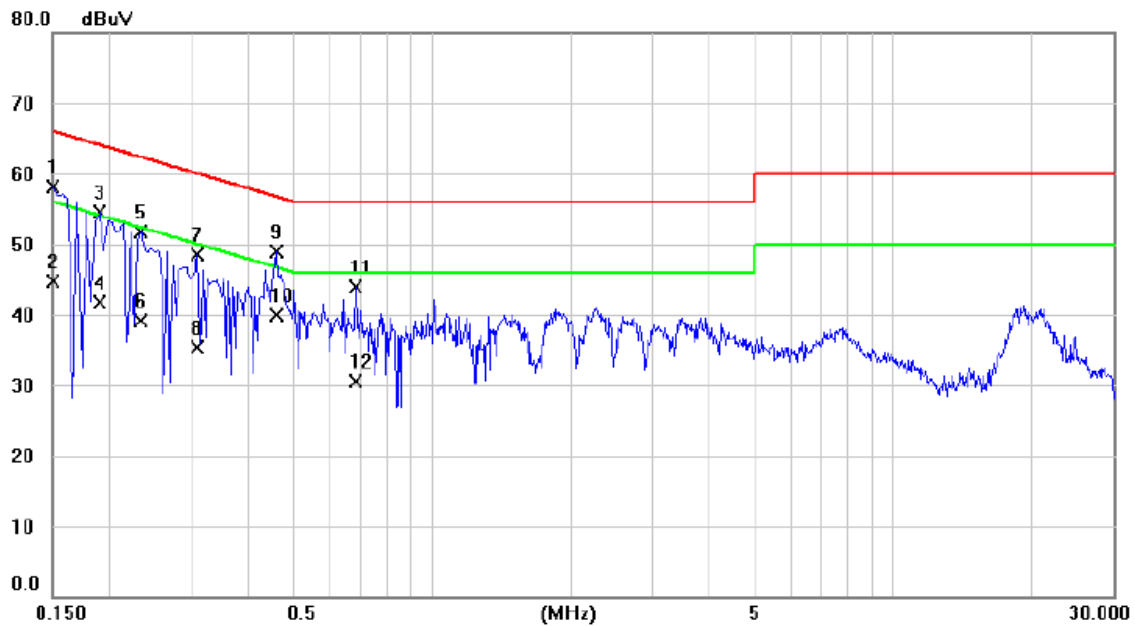

No.	Mk.	Freq. MHz	Reading Level dBuV	Correct Factor dB	Measure- ment dBuV	Limit dBuV	Margin dB	Detector	Comment
1		0.1500	48.67	9.52	58.19	66.00	-7.81	QP	
2		0.1500	35.10	9.52	44.62	56.00	-11.38	AVG	
3		0.1900	44.90	9.53	54.43	64.04	-9.61	QP	
4		0.1900	32.10	9.53	41.63	54.04	-12.41	AVG	
5		0.2340	42.21	9.53	51.74	62.31	-10.57	QP	
6		0.2340	29.50	9.53	39.03	52.31	-13.28	AVG	
7		0.3100	39.06	9.53	48.59	59.97	-11.38	QP	
8		0.3100	25.70	9.53	35.23	49.97	-14.74	AVG	
9		0.4580	39.36	9.60	48.96	56.73	-7.77	QP	
10	*	0.4580	30.40	9.60	40.00	46.73	-6.73	AVG	
11		0.6820	34.20	9.65	43.85	56.00	-12.15	QP	
12		0.6820	20.90	9.65	30.55	46.00	-15.45	AVG	

E.U.T :	LCD Monitor	Model Name :	238LM00009
Temperature :	25° C	Relative Humidity :	53%
Pressure :	1013 hPa	Test Voltage :	AC 230V/50Hz
Test Mode :	HDMI 1080P 1.8m (715G8083)	Phase:	Neutral
Test Engineer :	Lucky Mao		

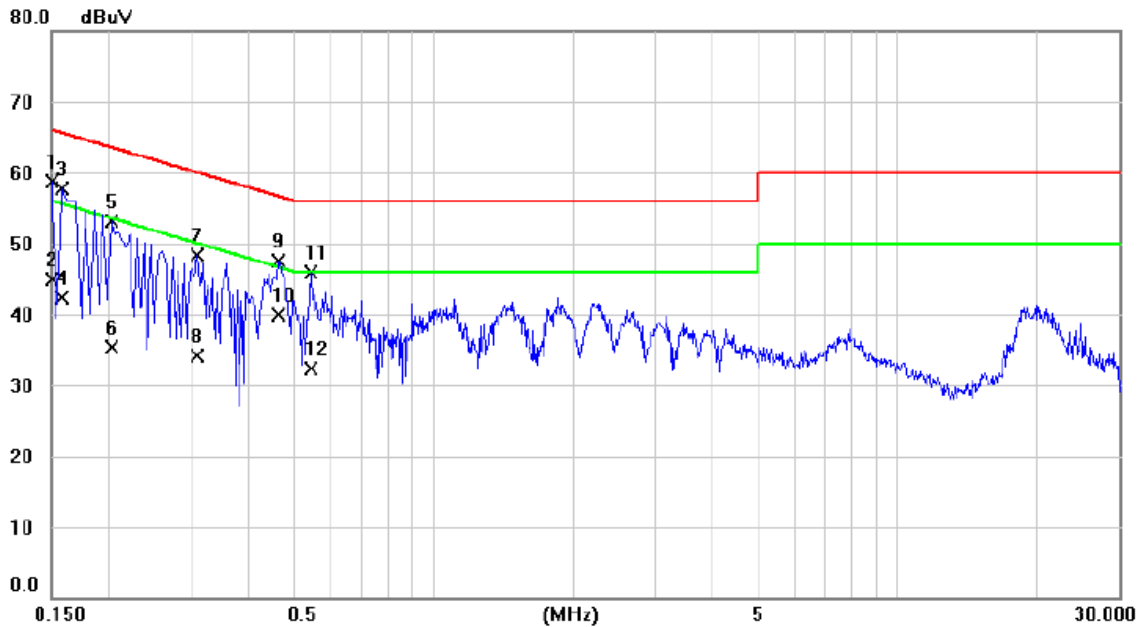

No.	Mk.	Freq. MHz	Reading Level dBuV	Correct Factor dB	Measure- ment dBuV	Limit dBuV	Margin dB	Detector	Comment
1		0.1500	49.26	9.52	58.78	66.00	-7.22	QP	
2		0.1500	35.30	9.52	44.82	56.00	-11.18	AVG	
3		0.1580	48.16	9.48	57.64	65.57	-7.93	QP	
4		0.1580	32.90	9.48	42.38	55.57	-13.19	AVG	
5		0.2020	43.49	9.53	53.02	63.53	-10.51	QP	
6		0.2020	25.80	9.53	35.33	53.53	-18.20	AVG	
7		0.3100	38.77	9.53	48.30	59.97	-11.67	QP	
8		0.3100	24.60	9.53	34.13	49.97	-15.84	AVG	
9		0.4620	38.13	9.44	47.57	56.66	-9.09	QP	
10	*	0.4620	30.50	9.44	39.94	46.66	-6.72	AVG	
11		0.5460	36.47	9.44	45.91	56.00	-10.09	QP	
12		0.5460	22.80	9.44	32.24	46.00	-13.76	AVG	

E.U.T :	LCD Monitor	Model Name :	238LM00009
Temperature :	25° C	Relative Humidity :	53%
Pressure :	1013 hPa	Test Voltage :	AC 230V/50Hz
Test Mode :	HDMI 2560*1440 60Hz 1.5m Display+HDMI+Audio+USB cable (715G8083)		
Test Engineer :	Lucky Mao		

Line

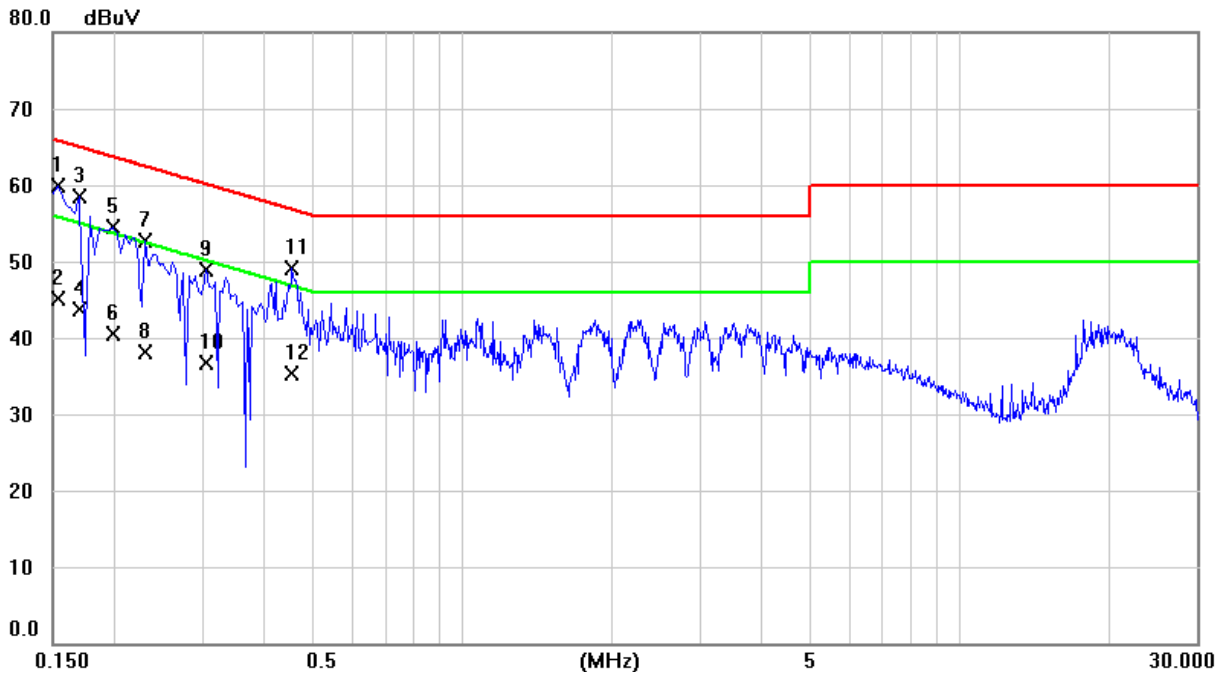

Neutral

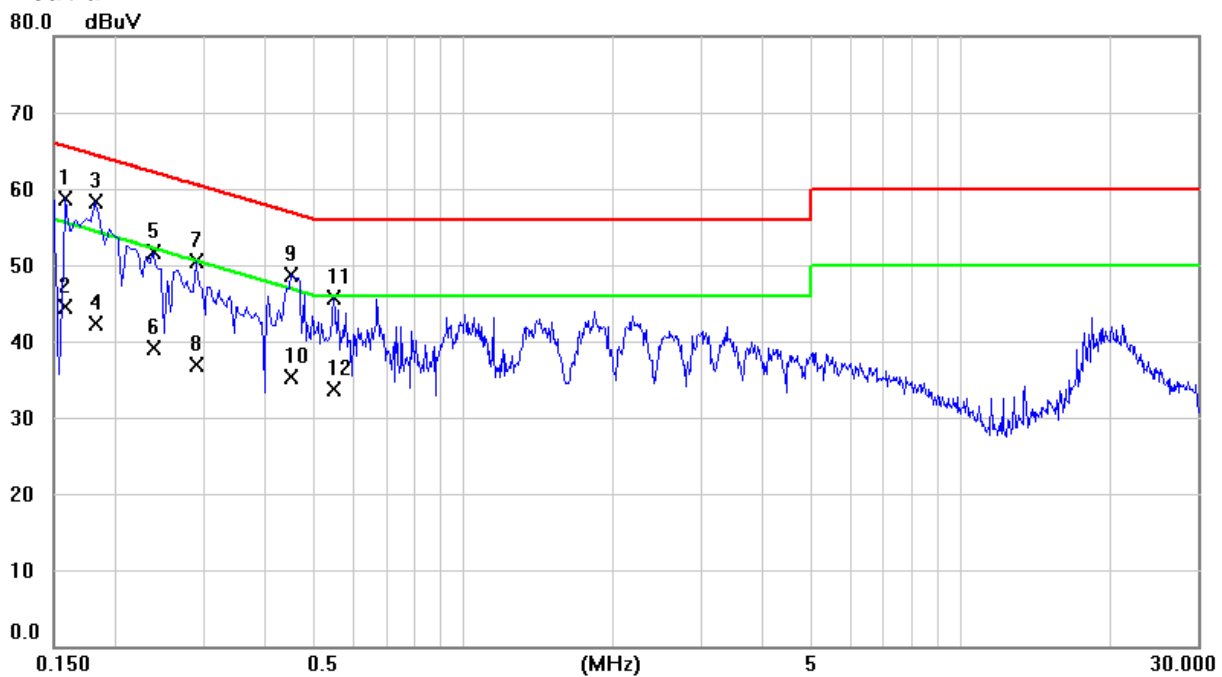

E.U.T :	LCD Monitor	Model Name :	238LM00009
Temperature :	25° C	Relative Humidity :	53%
Pressure :	1013 hPa	Test Voltage :	AC 230V/50Hz
Test Mode :	HDMI 2560*1440 60Hz 1.2m Display+HDMI+Audio+USB cable (715G8083)		
Test Engineer :	Lucky Mao		

Line

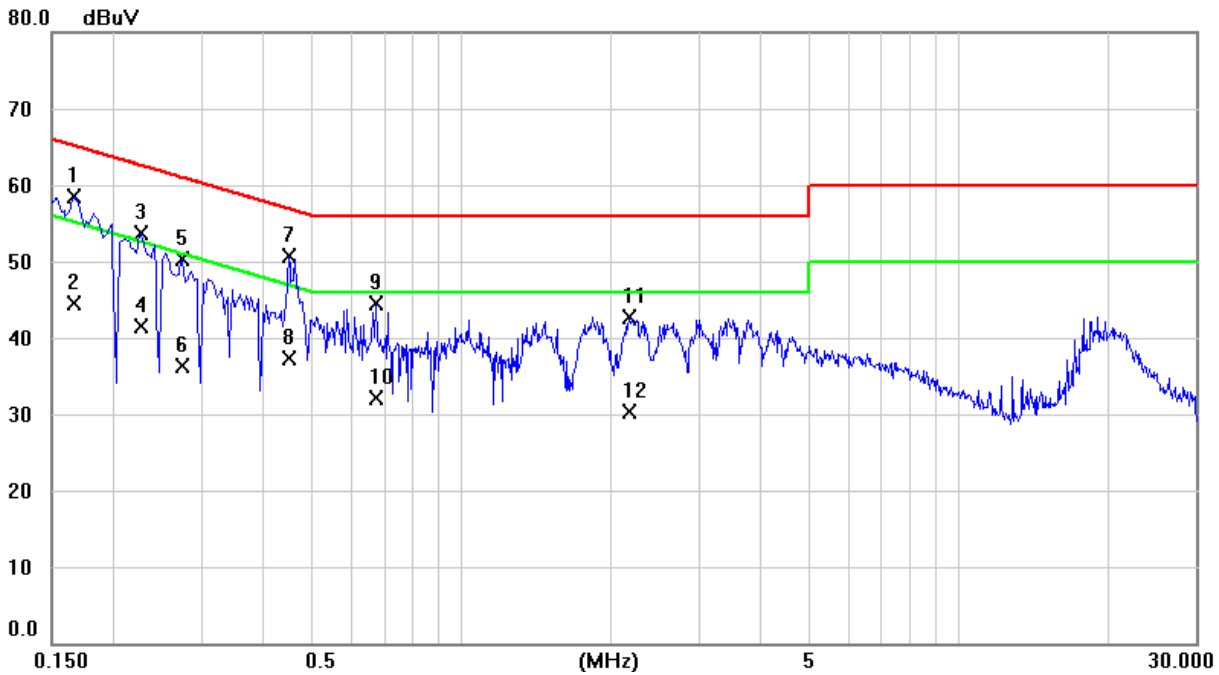

Neutral

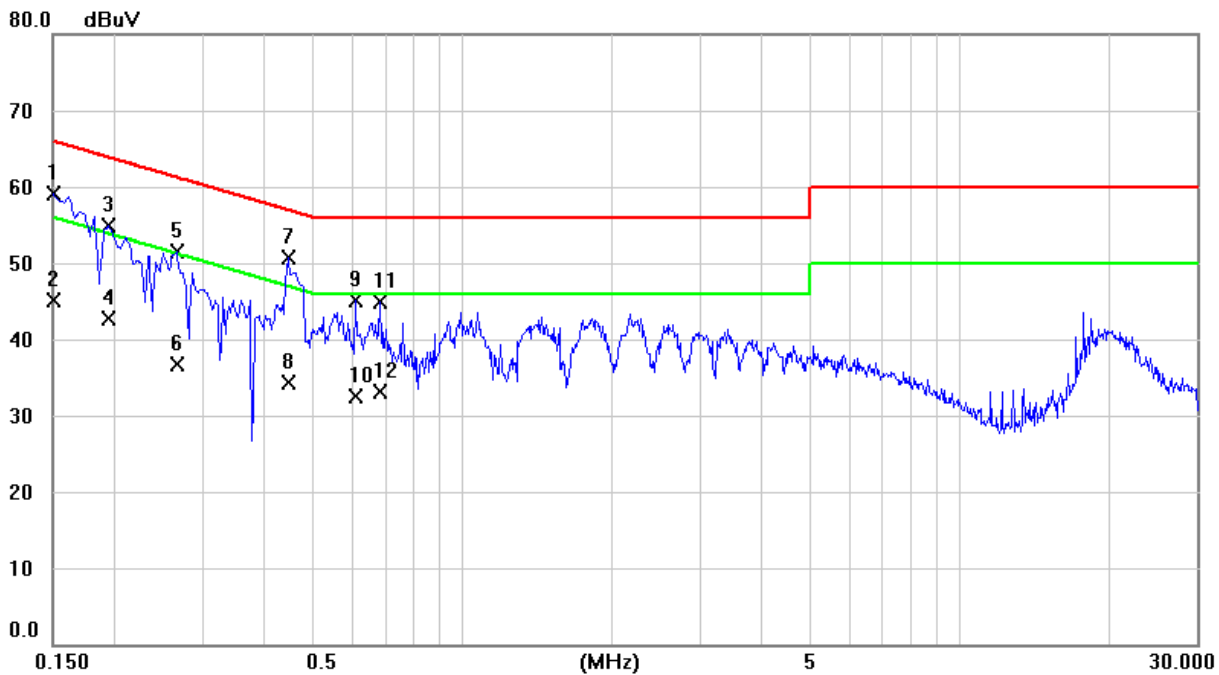

E.U.T :	LCD Monitor	Model Name :	238LM00009
Temperature :	25° C	Relative Humidity :	53%
Pressure :	1013 hPa	Test Voltage :	AC 230V/50Hz
Test Mode :	Display 2560*1440 144Hz 1.8m D-SUB+DVI+HDMI+Display+Audio +USB cable (715G8055)	Phase:	Line
Test Engineer :	Lucky Mao		

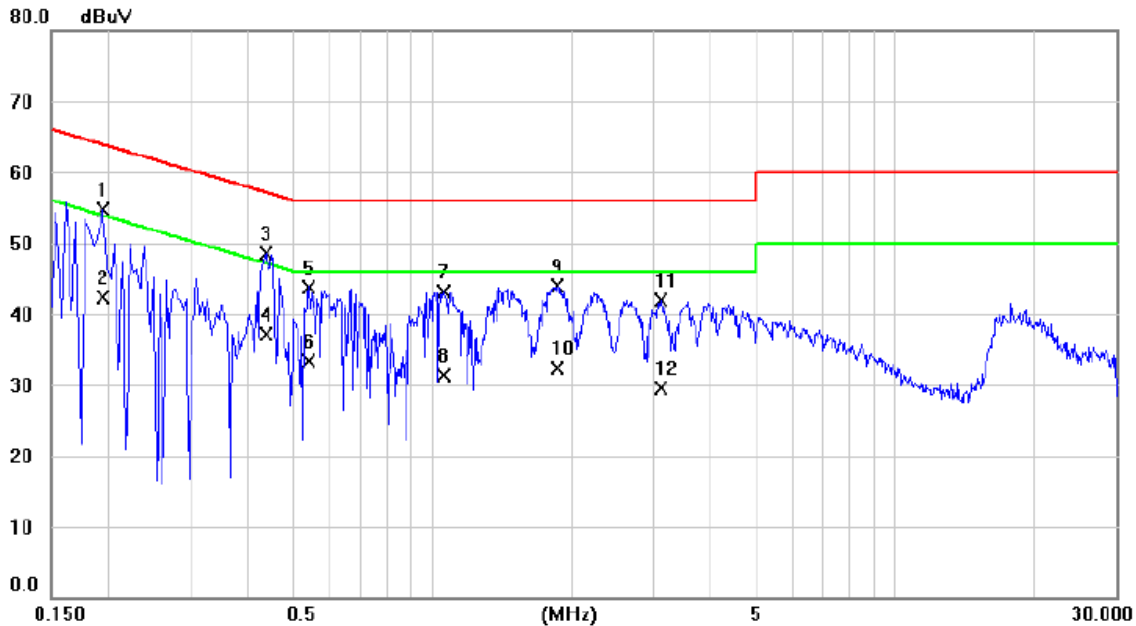

No.	Mk.	Freq. MHz	Reading Level dBuV	Correct Factor dB	Measure- ment dBuV	Limit dBuV	Margin dB	Detector	Comment
1		0.1940	45.23	9.53	54.76	63.86	-9.10	QP	
2		0.1940	32.70	9.53	42.23	53.86	-11.63	AVG	
3	*	0.4380	39.02	9.58	48.60	57.10	-8.50	QP	
4		0.4380	27.50	9.58	37.08	47.10	-10.02	AVG	
5		0.5420	34.16	9.64	43.80	56.00	-12.20	QP	
6		0.5420	23.60	9.64	33.24	46.00	-12.76	AVG	
7		1.0580	33.26	9.76	43.02	56.00	-12.98	QP	
8		1.0580	21.50	9.76	31.26	46.00	-14.74	AVG	
9		1.8620	33.98	9.89	43.87	56.00	-12.13	QP	
10		1.8620	22.50	9.89	32.39	46.00	-13.61	AVG	
11		3.1100	31.71	10.10	41.81	56.00	-14.19	QP	
12		3.1100	19.50	10.10	29.60	46.00	-16.40	AVG	

E.U.T :	LCD Monitor	Model Name :	238LM00009
Temperature :	25° C	Relative Humidity :	53%
Pressure :	1013 hPa	Test Voltage :	AC 230V/50Hz
Test Mode :	Display 2560*1440 144Hz 1.8m D-SUB+DVI+HDMI+Display+Audio +USB cable (715G8055)	Phase:	Neutral
Test Engineer :	Lucky Mao		

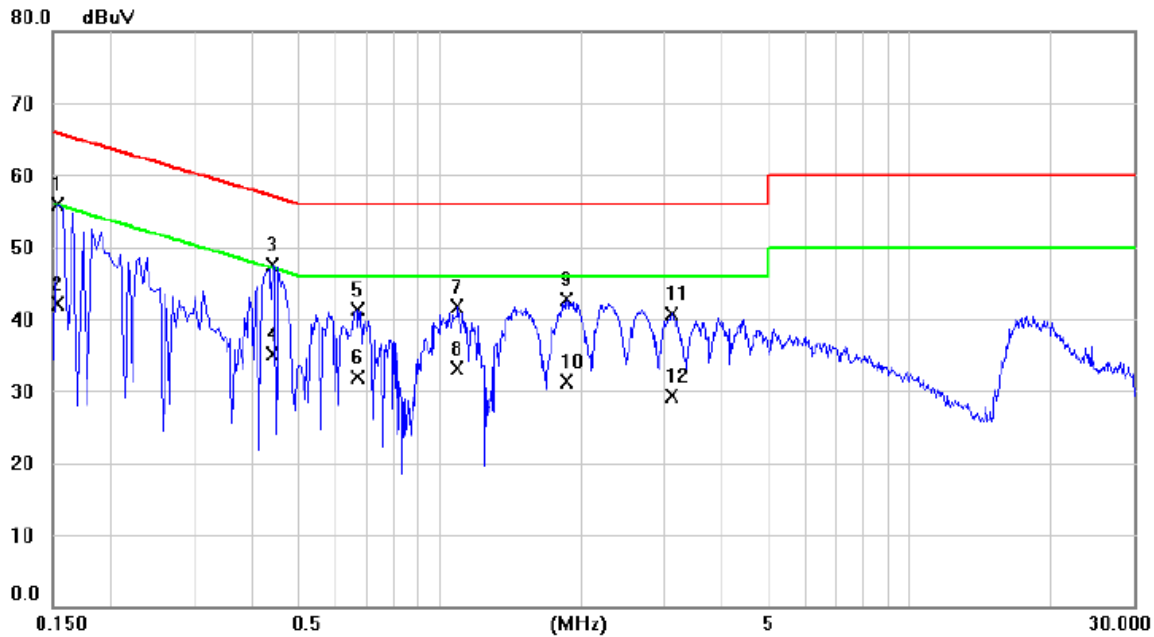

No.	Mk.	Freq. MHz	Reading Level dBuV	Correct Factor dB	Measure- ment dBuV	Limit dBuV	Margin dB	Detector	Comment
1		0.1540	46.43	9.50	55.93	65.78	-9.85	QP	
2		0.1540	32.70	9.50	42.20	55.78	-13.58	AVG	
3	*	0.4420	37.97	9.44	47.41	57.02	-9.61	QP	
4		0.4420	25.60	9.44	35.04	47.02	-11.98	AVG	
5		0.6660	31.86	9.45	41.31	56.00	-14.69	QP	
6		0.6660	22.50	9.45	31.95	46.00	-14.05	AVG	
7		1.0900	32.06	9.66	41.72	56.00	-14.28	QP	
8		1.0900	23.40	9.66	33.06	46.00	-12.94	AVG	
9		1.8660	33.01	9.69	42.70	56.00	-13.30	QP	
10		1.8660	21.70	9.69	31.39	46.00	-14.61	AVG	
11		3.1140	30.92	9.80	40.72	56.00	-15.28	QP	
12		3.1140	19.50	9.80	29.30	46.00	-16.70	AVG	

E.U.T :	LCD Monitor	Model Name :	238LM00009
Temperature :	25° C	Relative Humidity :	53%
Pressure :	1013 hPa	Test Voltage :	AC 230V/50Hz
Test Mode :	HDMI 2 2560*1440 144Hz 1.8m D-SUB+DVI+HDMI+Display+Audio +USB cable (715G8055)	Phase:	Line
Test Engineer :	Lucky Mao		

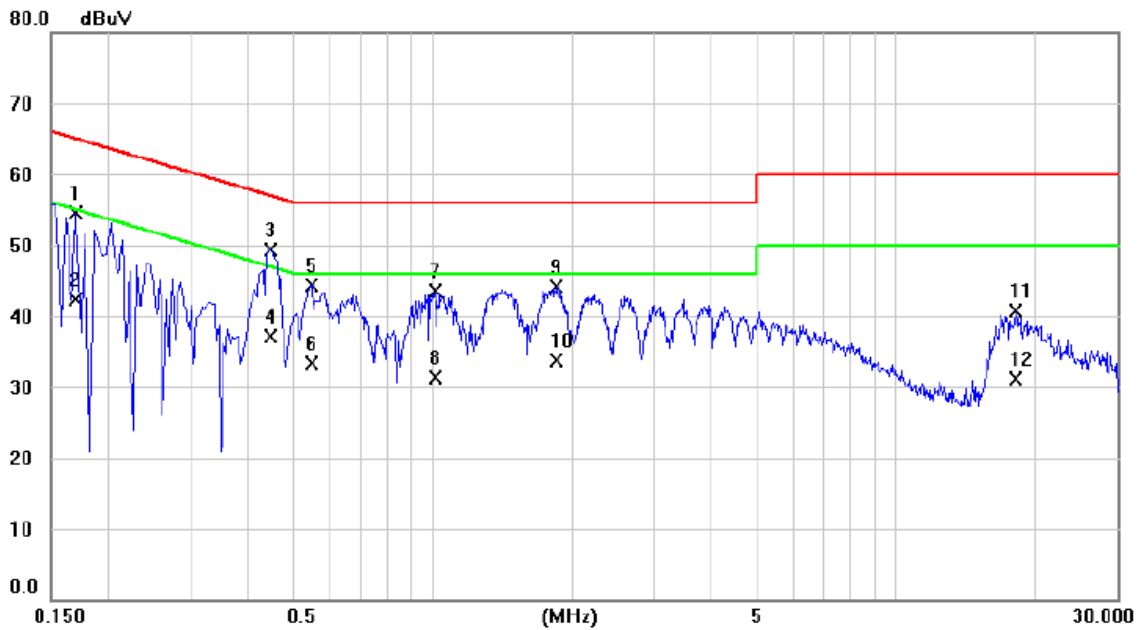

No.	Mk.	Freq. MHz	Reading Level dBuV	Correct Factor dB	Measure- ment dBuV	Limit dBuV	Margin dB	Detector	Comment
1		0.1700	45.01	9.52	54.53	64.96	-10.43	QP	
2		0.1700	32.70	9.52	42.22	54.96	-12.74	AVG	
3	*	0.4460	39.67	9.59	49.26	56.95	-7.69	QP	
4		0.4460	27.50	9.59	37.09	46.95	-9.86	AVG	
5		0.5500	34.67	9.64	44.31	56.00	-11.69	QP	
6		0.5500	23.60	9.64	33.24	46.00	-12.76	AVG	
7		1.0140	33.76	9.76	43.52	56.00	-12.48	QP	
8		1.0140	21.50	9.76	31.26	46.00	-14.74	AVG	
9		1.8540	34.26	9.89	44.15	56.00	-11.85	QP	
10		1.8540	23.80	9.89	33.69	46.00	-12.31	AVG	
11		18.1100	30.24	10.38	40.62	60.00	-19.38	QP	
12		18.1100	20.80	10.38	31.18	50.00	-18.82	AVG	

E.U.T :	LCD Monitor	Model Name :	238LM00009
Temperature :	25° C	Relative Humidity :	53%
Pressure :	1013 hPa	Test Voltage :	AC 230V/50Hz
Test Mode :	HDMI 2 2560*1440 144Hz 1.8m D-SUB+DVI+HDMI+Display+Audio +USB cable (715G8055)	Phase:	Neutral
Test Engineer :	Lucky Mao		

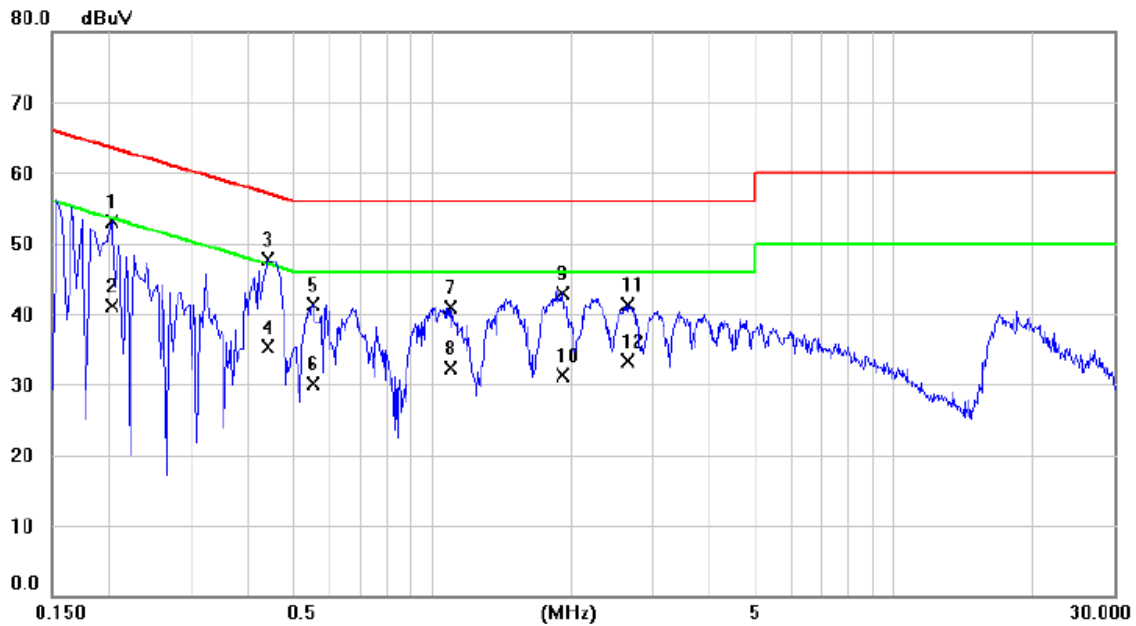

No.	Mk.	Freq. MHz	Reading Level dBuV	Correct Factor dB	Measure- ment dBuV	Limit dBuV	Margin dB	Detector	Comment
1		0.2020	43.65	9.53	53.18	63.53	-10.35	QP	
2		0.2020	31.50	9.53	41.03	53.53	-12.50	AVG	
3	*	0.4420	38.33	9.44	47.77	57.02	-9.25	QP	
4		0.4420	25.90	9.44	35.34	47.02	-11.68	AVG	
5		0.5540	31.86	9.44	41.30	56.00	-14.70	QP	
6		0.5540	20.70	9.44	30.14	46.00	-15.86	AVG	
7		1.0980	31.25	9.66	40.91	56.00	-15.09	QP	
8		1.0980	22.60	9.66	32.26	46.00	-13.74	AVG	
9		1.9100	33.15	9.69	42.84	56.00	-13.16	QP	
10		1.9100	21.70	9.69	31.39	46.00	-14.61	AVG	
11		2.6460	31.52	9.79	41.31	56.00	-14.69	QP	
12		2.6460	23.50	9.79	33.29	46.00	-12.71	AVG	

E.U.T :	LCD Monitor	Model Name :	238LM00009
Temperature :	25° C	Relative Humidity :	53%
Pressure :	1013 hPa	Test Voltage :	AC 230V/50Hz
Test Mode :	HDMI 2 1080P 1.8m (715G8055)	Phase:	Line
Test Engineer :	Lucky Mao		

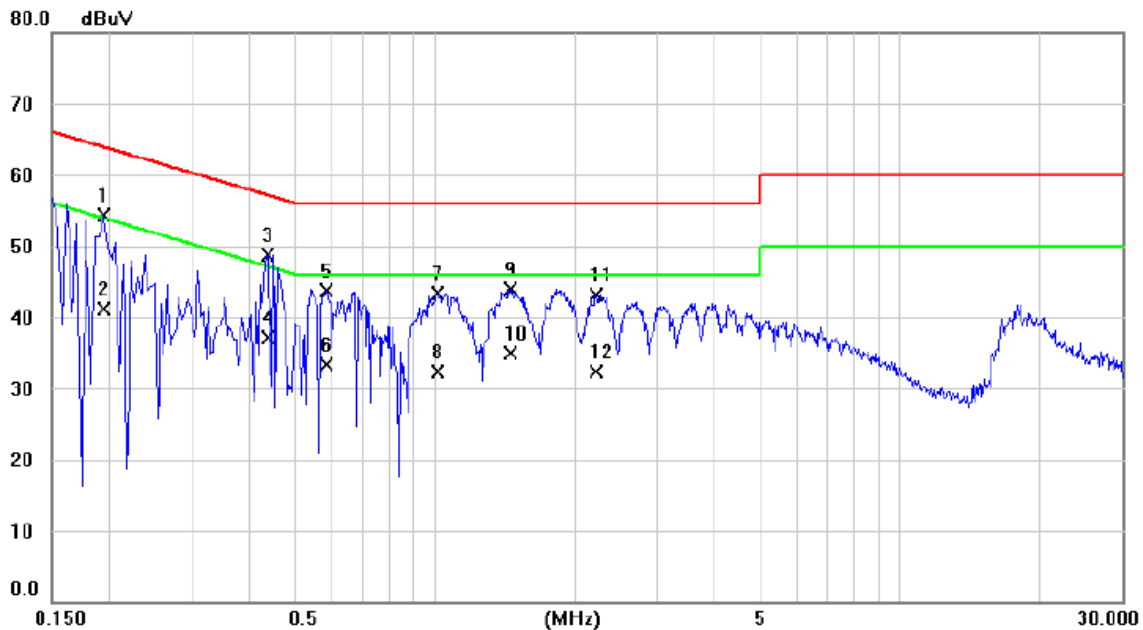

No.	Mk.	Freq. MHz	Reading Level dBuV	Correct Factor dB	Measure- ment dBuV	Limit dBuV	Margin dB	Detector	Comment
1		0.1940	44.71	9.53	54.24	63.86	-9.62	QP	
2		0.1940	31.50	9.53	41.03	53.86	-12.83	AVG	
3	*	0.4380	39.05	9.58	48.63	57.10	-8.47	QP	
4		0.4380	27.50	9.58	37.08	47.10	-10.02	AVG	
5		0.5860	34.07	9.64	43.71	56.00	-12.29	QP	
6		0.5860	23.60	9.64	33.24	46.00	-12.76	AVG	
7		1.0140	33.63	9.76	43.39	56.00	-12.61	QP	
8		1.0140	22.50	9.76	32.26	46.00	-13.74	AVG	
9		1.4540	34.12	9.85	43.97	56.00	-12.03	QP	
10		1.4540	25.10	9.85	34.95	46.00	-11.05	AVG	
11		2.2180	33.13	9.98	43.11	56.00	-12.89	QP	
12		2.2180	22.40	9.98	32.38	46.00	-13.62	AVG	

E.U.T :	LCD Monitor	Model Name :	238LM00009
Temperature :	25° C	Relative Humidity :	53%
Pressure :	1013 hPa	Test Voltage :	AC 230V/50Hz
Test Mode :	HDMI 2 1080P 1.8m (715G8055)	Phase:	Neutral
Test Engineer :	Lucky Mao		

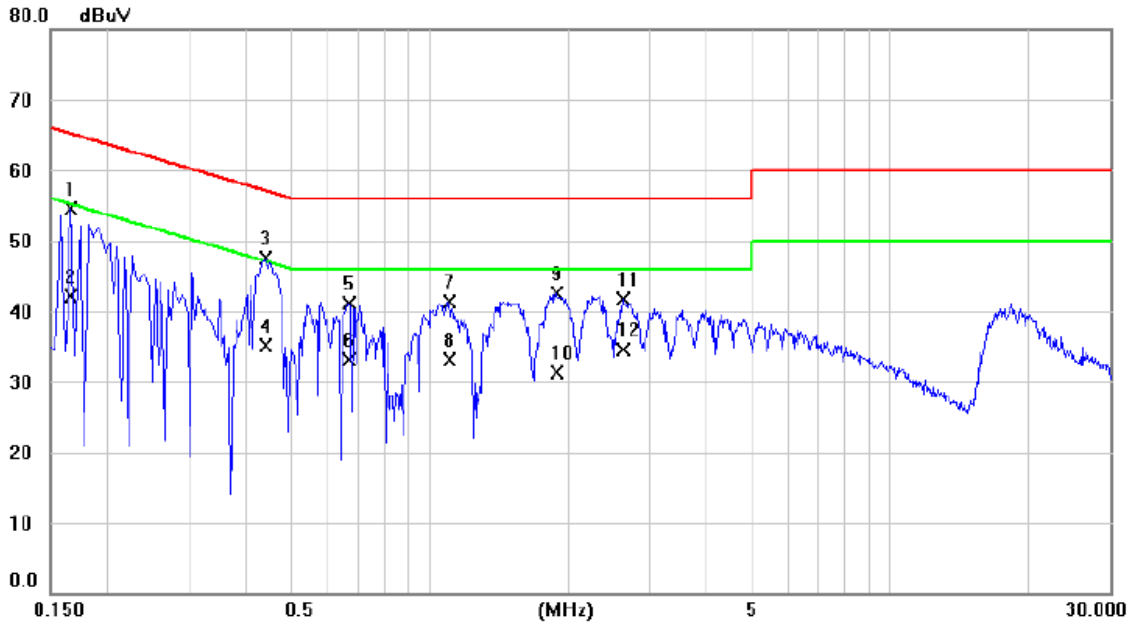

No.	Mk.	Freq. MHz	Reading Level dBuV	Correct Factor dB	Measure- ment dBuV	Limit dBuV	Margin dB	Detector	Comment
1		0.1660	45.12	9.44	54.56	65.16	-10.60	QP	
2		0.1660	32.70	9.44	42.14	55.16	-13.02	AVG	
3	*	0.4420	38.07	9.44	47.51	57.02	-9.51	QP	
4		0.4420	25.60	9.44	35.04	47.02	-11.98	AVG	
5		0.6660	31.66	9.45	41.11	56.00	-14.89	QP	
6		0.6660	23.60	9.45	33.05	46.00	-12.95	AVG	
7		1.1060	31.74	9.66	41.40	56.00	-14.60	QP	
8		1.1060	23.50	9.66	33.16	46.00	-12.84	AVG	
9		1.8820	32.77	9.69	42.46	56.00	-13.54	QP	
10		1.8820	21.70	9.69	31.39	46.00	-14.61	AVG	
11		2.6260	31.83	9.79	41.62	56.00	-14.38	QP	
12		2.6260	24.80	9.79	34.59	46.00	-11.41	AVG	

E.U.T :	LCD Monitor	Model Name :	238LM00009
Temperature :	25° C	Relative Humidity :	53%
Pressure :	1013 hPa	Test Voltage :	AC 230V/50Hz
Test Mode :	HDMI 2 2560*1440 144Hz 1.5m D-SUB+DVI+HDMI+Display+Audio+USB cable (715G8055)		
Test Engineer :	Lucky Mao		

Line

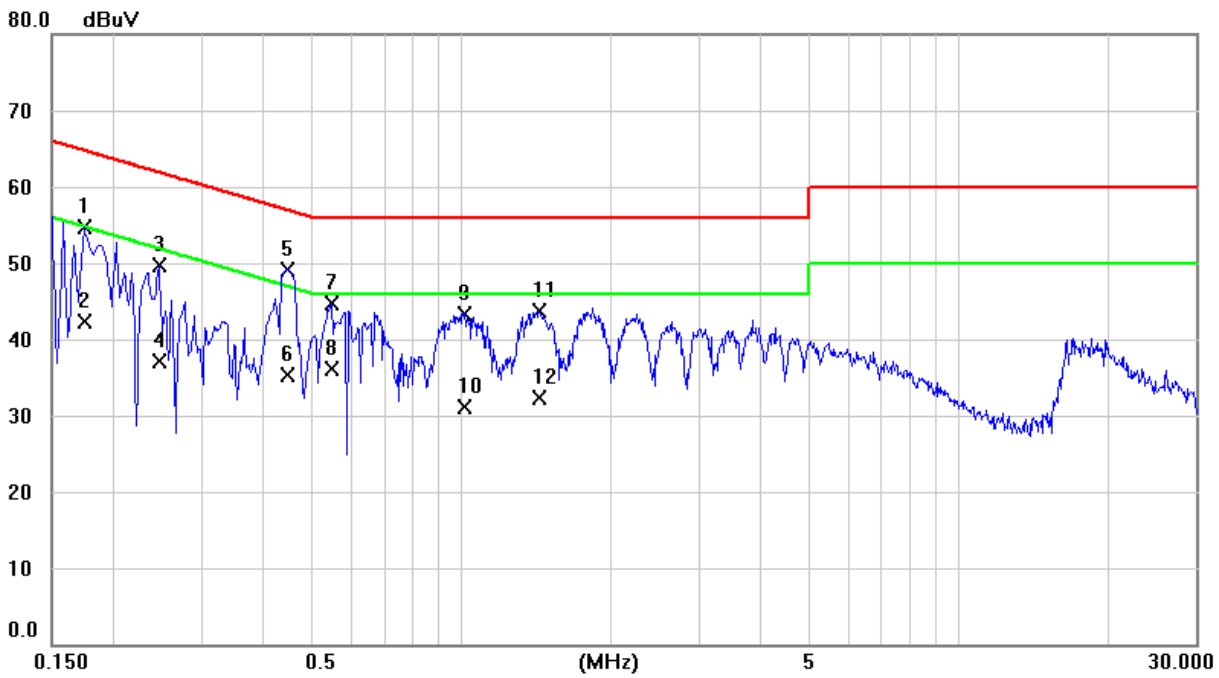

Neutral

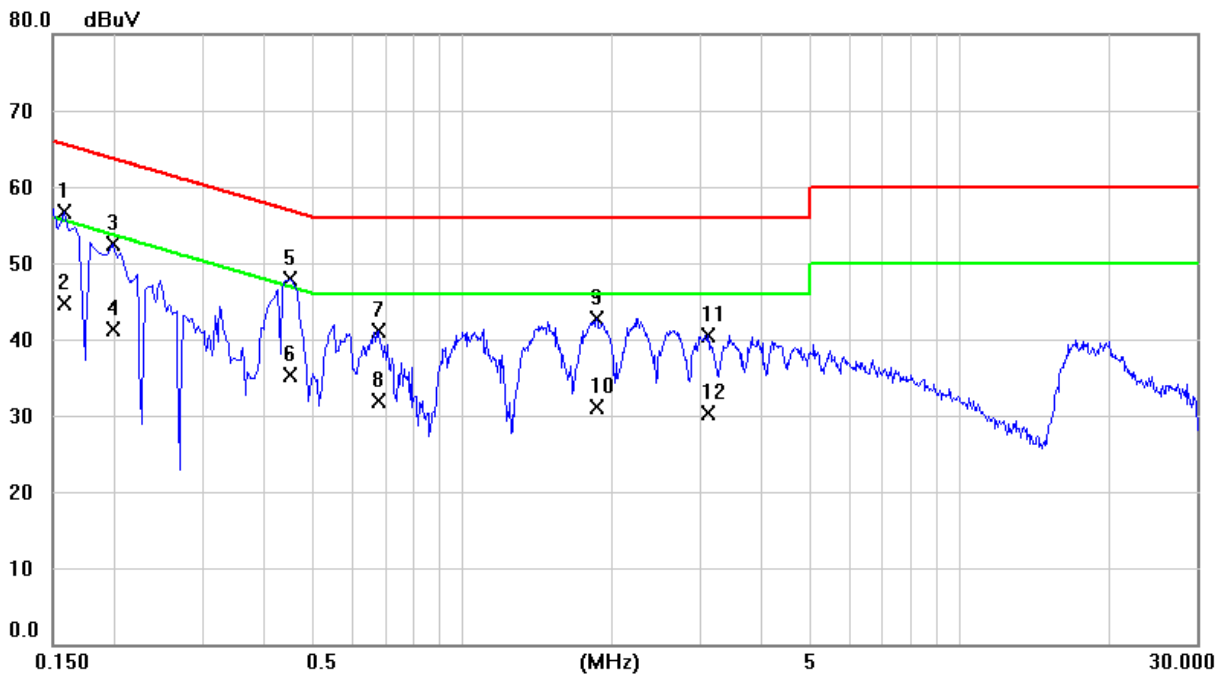

E.U.T :	LCD Monitor	Model Name :	238LM00009
Temperature :	25° C	Relative Humidity :	53%
Pressure :	1013 hPa	Test Voltage :	AC 230V/50Hz
Test Mode :	HDMI 2 2560*1440 144Hz 1.2m D-SUB+DVI+HDMI+Display+Audio+USB cable (715G8055)		
Test Engineer :	Lucky Mao		

Line

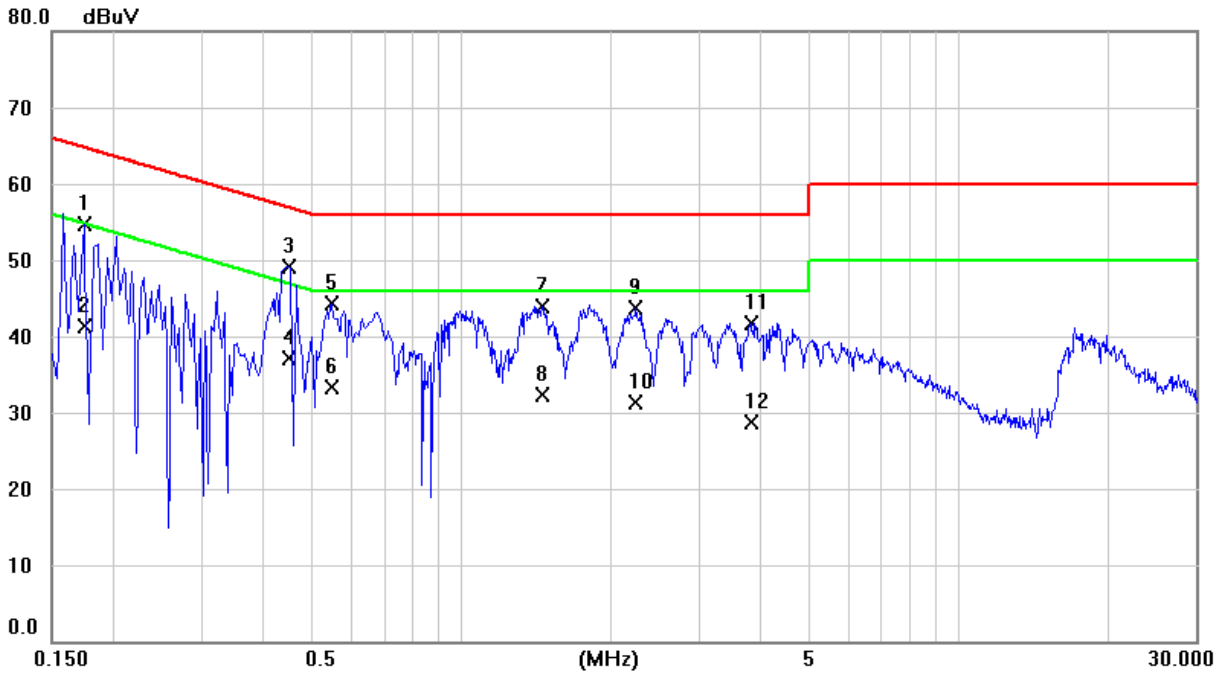

Neutral

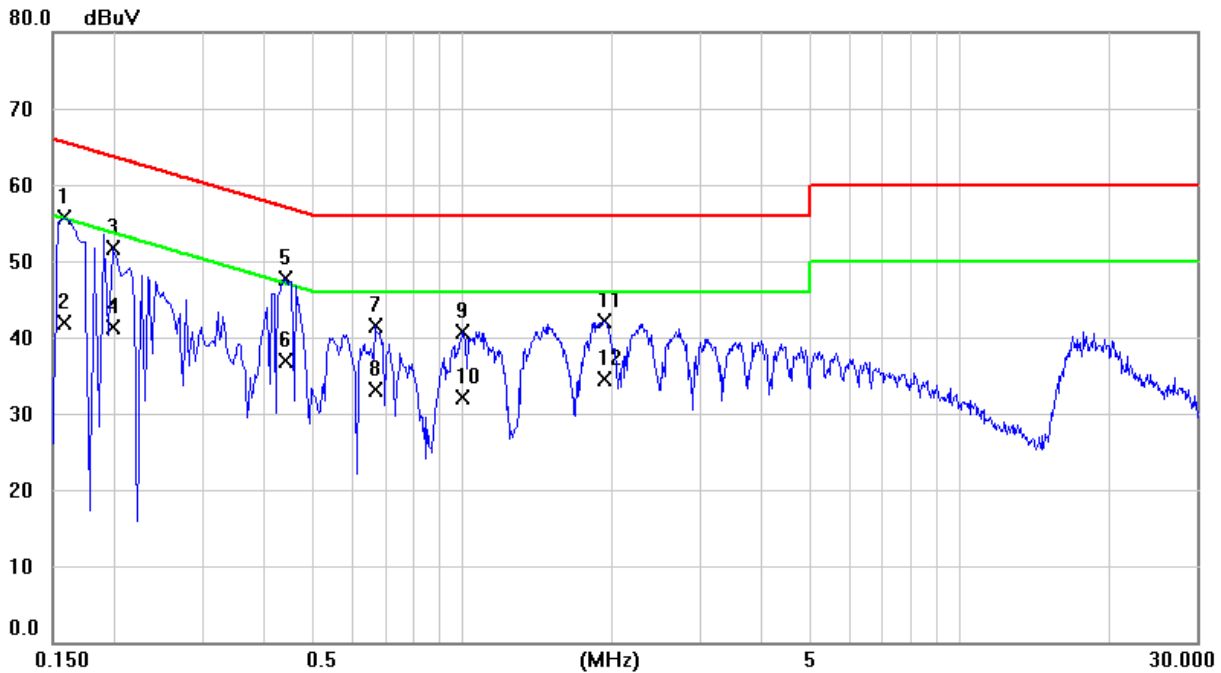

4.3 HARMONIC CURRENT EMISSIONS TEST

4.3.1 LIMITS

EN 61000-3-2						
Equipment Category	Harmonic Order n	Max. Permissible Harmonic Current A	Equipment Category	Harmonic Order n	Max. Permissible Harmonic Current A mA/w	
Class A	Odd Harmonics		Class D	Odd Harmonics only		
	3	2.30		3	2.30	3.4
	5	1.14		5	1.14	1.9
	7	0.77		7	0.77	1.0
	9	0.40		9	0.40	0.5
	11	0.33		11	0.33	0.35
	13	0.21		13	0.21	0.30
	15≤n≤39	0.15 x 15/n		15≤n≤39	0.15 x 15/n	3.85/n
	Even Harmonics					
	2	1.08				
	4	0.43				
	6	0.30				
	8≤n≤40	0.23 x 8/n				

4.3.2 MEASUREMENT INSTRUMENTS LIST

Item	Kind of Equipment	Manufacturer	Type No.	Serial No.	Calibrated until
1	Harmonic & Flicker	California	PACS-1	72344	Sep. 06, 2016
2	Power Source	California	3001iX	56309	Sep. 06, 2016
3	Measurement Software	California	CTS4.0 Version 4.9	N/A	N/A

Remark: "N/A" denotes no model name, no serial no. or no calibration specified.
All calibration period of equipment list is one year.

4.3.3 TEST PROCEDURE

- a. The EUT was placed on the top of a wooden table 0.8 meters above the ground and operated to produce the maximum harmonic components under normal operating conditions.
- b. The classification of EUT is according to of EN 61000-3-2. The EUT is classified as follows:
 - Class A: Balanced three-phase equipment, Household appliances excluding equipment as Class D, Tools excluding portable tools, Dimmers for incandescent lamps, audio equipment, equipment not specified in one of the three other classes.
 - Class B: Portable tools. Portable tools; Arc welding equipment which is not professional equipment.
 - Class C: Lighting equipment.
 - Class D: Equipment having a specified power less than or equal to 600 W of the following types: Personal computers and personal computer monitors and television receivers.
- c. The correspondent test program of test instrument to measure the current harmonics emanated from EUT is chosen. The measure time shall be not less than the time necessary for the EUT to be exercised.

4.3.4 DEVIATION FROM TEST STANDARD

No deviation

4.3.5 TEST SETUP

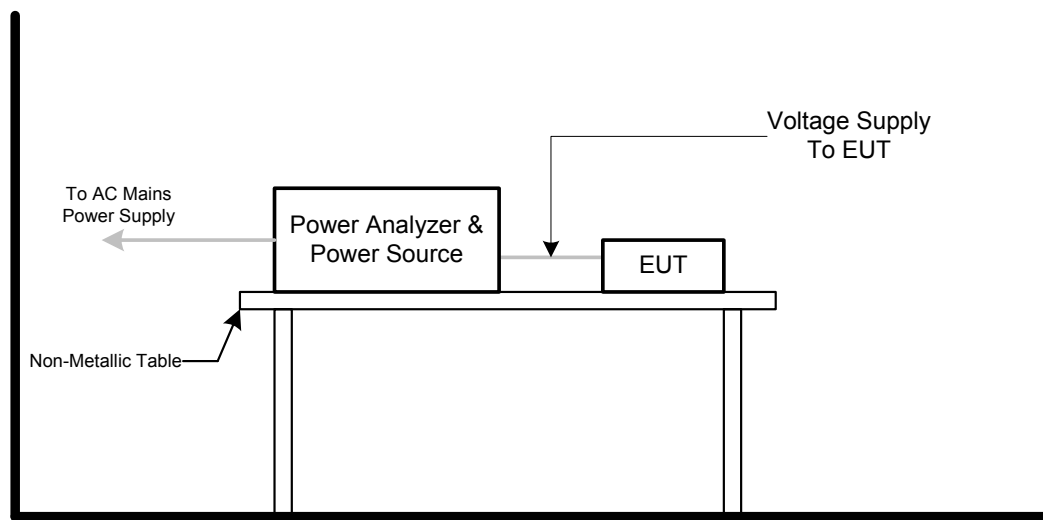

4.3.6 EUT OPERATING CONDITIONS

The EUT tested system was configured as the statements of 4.1.6 unless otherwise a special operating condition is specified in the follows during the testing.

4.3.7 TEST RESULTS

Harmonics – Class D			
E.U.T	LCD Monitor	Model Name	238LM00009
Temperature	26 °C	Relative Humidity	45%
Test Voltage	AC 230V/50Hz		
Test Mode	HDMI 2560*1440 60Hz (715G8083)		

Current & voltage waveforms

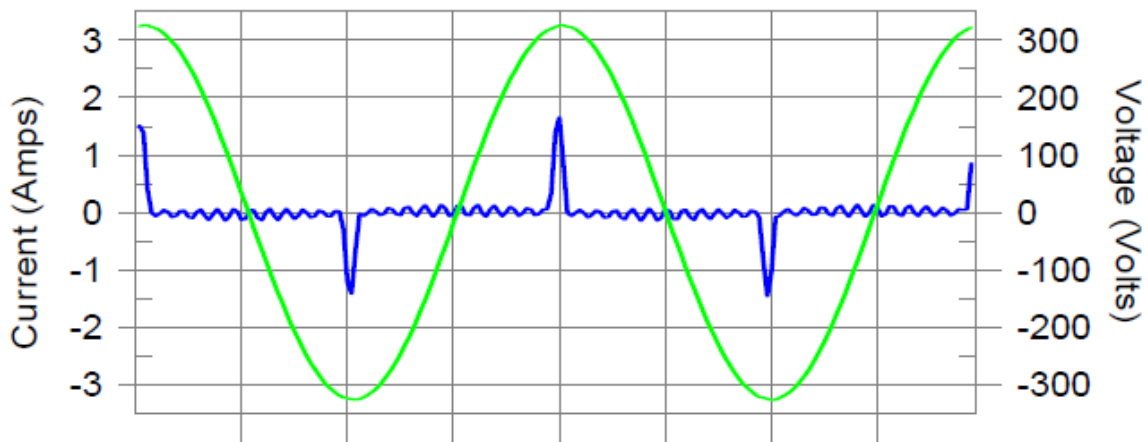

Harmonics and Class D limit line European Limits

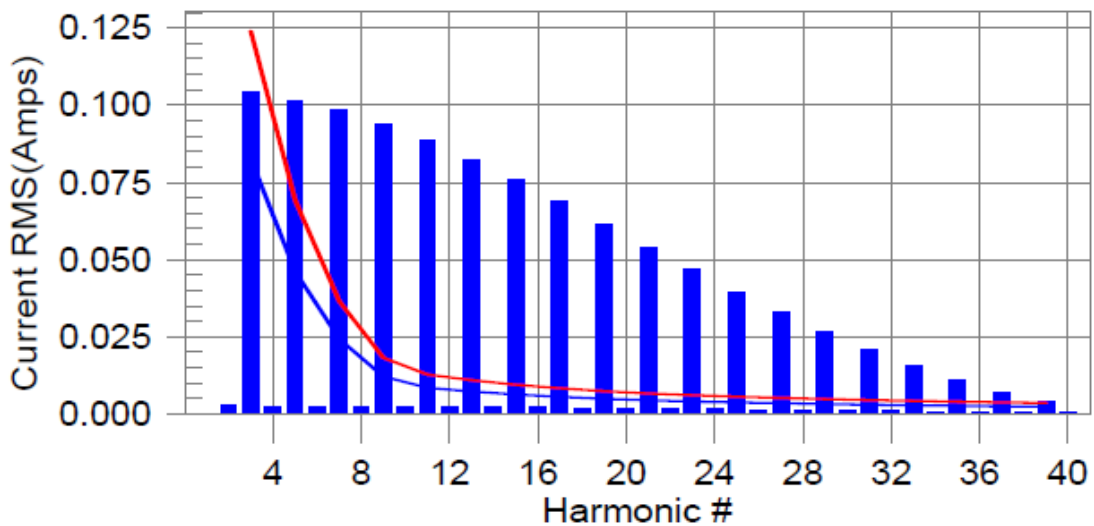

Test result: N/L Worst harmonic was #19 with 831.6% of the limit.

Current Test Result Summary (Run time)

E.U.T	LCD Monitor	Model Name	238LM00009
Temperature	26 °C	Relative Humidity	45%
Test Voltage	AC 230V/50Hz		
Test Mode	HDMI 2560*1440 60Hz (715G8083)		

THC(A): 0.000 I-THD(%): 0.0 POHC(A): 0.000 POHC Limit(A): 0.000

Highest parameter values during test:

V_RMS (Volts): 230.07	Frequency(Hz): 50.00
I_Peak (Amps): 1.726	I_RMS (Amps): 0.307
I_Fund (Amps): 0.110	Crest Factor: 5.638
Power (Watts): 24.3	Power Factor: 0.347

Harm#	Harms(avg)	100%Limit	%of Limit	Harms(max)	150%Limit	%of Limit	Status
2	0.003	0.000	N/A	0.004	0.000	N/A	N/L
3	0.104	0.083	N/A	0.106	0.124	N/A	N/L
4	0.003	0.000	N/A	0.003	0.000	N/A	N/L
5	0.102	0.046	N/A	0.102	0.069	N/A	N/L
6	0.002	0.000	N/A	0.003	0.000	N/A	N/L
7	0.098	0.024	N/A	0.098	0.036	N/A	N/L
8	0.002	0.000	N/A	0.003	0.000	N/A	N/L
9	0.094	0.012	N/A	0.094	0.018	N/A	N/L
10	0.002	0.000	N/A	0.003	0.000	N/A	N/L
11	0.088	0.009	N/A	0.089	0.013	N/A	N/L
12	0.002	0.000	N/A	0.003	0.000	N/A	N/L
13	0.082	0.007	N/A	0.082	0.011	N/A	N/L
14	0.002	0.000	N/A	0.003	0.000	N/A	N/L
15	0.076	0.006	N/A	0.076	0.009	N/A	N/L
16	0.002	0.000	N/A	0.003	0.000	N/A	N/L
17	0.069	0.006	N/A	0.069	0.008	N/A	N/L
18	0.002	0.000	N/A	0.002	0.000	N/A	N/L
19	0.061	0.005	N/A	0.062	0.007	N/A	N/L
20	0.002	0.000	N/A	0.002	0.000	N/A	N/L
21	0.054	0.004	N/A	0.054	0.007	N/A	N/L
22	0.002	0.000	N/A	0.002	0.000	N/A	N/L
23	0.047	0.004	N/A	0.047	0.006	N/A	N/L
24	0.002	0.000	N/A	0.002	0.000	N/A	N/L
25	0.040	0.004	N/A	0.040	0.006	N/A	N/L
26	0.001	0.000	N/A	0.002	0.000	N/A	N/L
27	0.033	0.003	N/A	0.033	0.005	N/A	N/L
28	0.001	0.000	N/A	0.002	0.000	N/A	N/L
29	0.026	0.003	N/A	0.027	0.005	N/A	N/L
30	0.001	0.000	N/A	0.001	0.000	N/A	N/L
31	0.021	0.003	N/A	0.021	0.005	N/A	N/L
32	0.001	0.000	N/A	0.001	0.000	N/A	N/L
33	0.016	0.003	N/A	0.016	0.004	N/A	N/L
34	0.001	0.000	N/A	0.001	0.000	N/A	N/L
35	0.011	0.003	N/A	0.011	0.004	N/A	N/L
36	0.001	0.000	N/A	0.001	0.000	N/A	N/L
37	0.007	0.003	N/A	0.007	0.004	N/A	N/L
38	0.000	0.000	N/A	0.001	0.000	N/A	N/L
39	0.004	0.002	N/A	0.004	0.004	N/A	N/L
40	0.000	0.000	N/A	0.001	0.000	N/A	N/L

Note: The EUT power level is below 75.0 Watts and therefore has no defined limits

Voltage Source Verification Data (Run time)

E.U.T	LCD Monitor	Model Name	238LM00009
Temperature	26 °C	Relative Humidity	45%
Test Voltage	AC 230V/50Hz		
Test Mode	HDMI 2560*1440 60Hz (715G8083)		

Highest parameter values during test:

Voltage (Vrms):	230.07	Frequency(Hz):	50.00
I_Peak (Amps):	1.726	I_RMS (Amps):	0.307
I_Fund (Amps):	0.110	Crest Factor:	5.638
Power (Watts):	24.3	Power Factor:	0.347

Harm#	Harmonics V-rms	Limit V-rms	% of Limit	Status
2	0.135	0.460	29.37	OK
3	0.604	2.070	29.15	OK
4	0.054	0.460	11.78	OK
5	0.063	0.920	6.80	OK
6	0.022	0.460	4.85	OK
7	0.071	0.690	10.30	OK
8	0.017	0.460	3.80	OK
9	0.025	0.460	5.52	OK
10	0.018	0.460	3.86	OK
11	0.062	0.230	27.07	OK
12	0.013	0.230	5.60	OK
13	0.055	0.230	23.89	OK
14	0.010	0.230	4.33	OK
15	0.058	0.230	25.38	OK
16	0.012	0.230	5.21	OK
17	0.053	0.230	23.03	OK
18	0.011	0.230	4.67	OK
19	0.060	0.230	26.00	OK
20	0.017	0.230	7.59	OK
21	0.053	0.230	22.98	OK
22	0.011	0.230	4.75	OK
23	0.054	0.230	23.29	OK
24	0.007	0.230	3.02	OK
25	0.045	0.230	19.43	OK
26	0.009	0.230	4.10	OK
27	0.043	0.230	18.69	OK
28	0.009	0.230	3.80	OK
29	0.032	0.230	13.75	OK
30	0.009	0.230	4.02	OK
31	0.032	0.230	14.07	OK
32	0.012	0.230	5.28	OK
33	0.024	0.230	10.23	OK
34	0.014	0.230	6.00	OK
35	0.022	0.230	9.75	OK
36	0.017	0.230	7.39	OK
37	0.014	0.230	6.01	OK
38	0.018	0.230	7.96	OK
39	0.014	0.230	5.92	OK
40	0.018	0.230	7.72	OK

Harmonics – Class D

E.U.T	LCD Monitor	Model Name	238LM00009
Temperature	26 °C	Relative Humidity	45%
Test Voltage	AC 230V/50Hz		
Test Mode	HDMI 2 2560*1440 144Hz (715G8055)		

Current & voltage waveforms

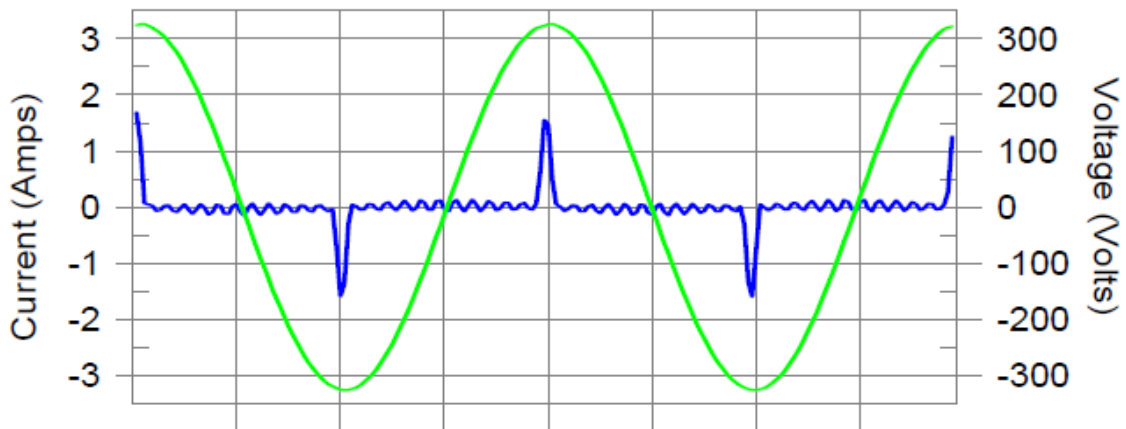

Harmonics and Class D limit line European Limits

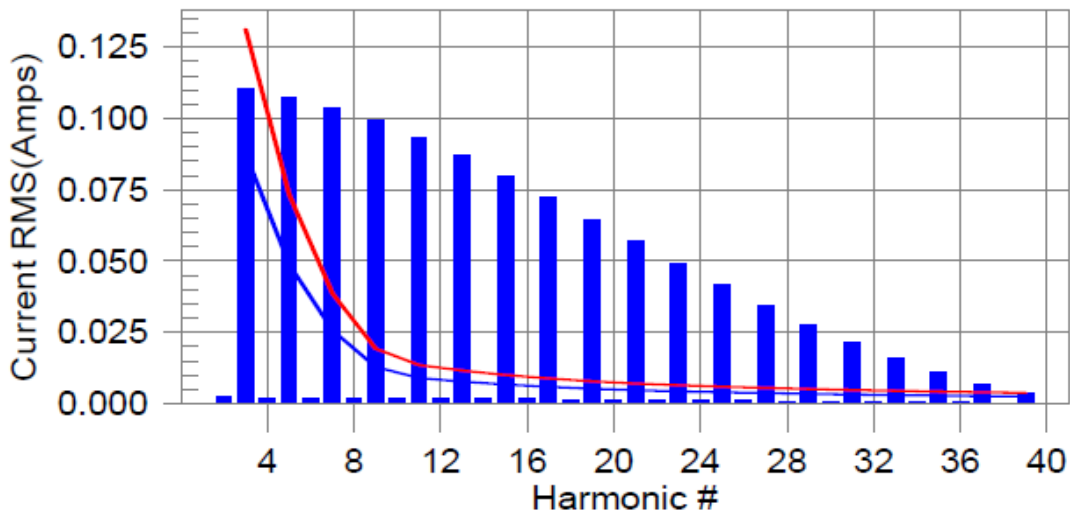

Test result: N/L Worst harmonic was #19 with 827.7% of the limit.

Current Test Result Summary (Run time)

E.U.T	LCD Monitor	Model Name	238LM00009
Temperature	26 °C	Relative Humidity	45%
Test Voltage	AC 230V/50Hz		
Test Mode	HDMI 2 2560*1440 144Hz (715G8055)		

THC(A): 0.000 I-THD(%): 0.0 POHC(A): 0.000 POHC Limit(A): 0.000

Highest parameter values during test:

V_RMS (Volts): 230.05	Frequency(Hz): 50.00
I_Peak (Amps): 1.732	I_RMS (Amps): 0.323
I_Fund (Amps): 0.116	Crest Factor: 5.373
Power (Watts): 25.8	Power Factor: 0.349

Harm#	Harms(avg)	100%Limit	%of Limit	Harms(max)	150%Limit	%of Limit	Status
2	0.002	0.000	N/A	0.003	0.000	N/A	N/L
3	0.110	0.088	N/A	0.112	0.131	N/A	N/L
4	0.002	0.000	N/A	0.003	0.000	N/A	N/L
5	0.108	0.049	N/A	0.108	0.073	N/A	N/L
6	0.002	0.000	N/A	0.003	0.000	N/A	N/L
7	0.104	0.026	N/A	0.104	0.039	N/A	N/L
8	0.002	0.000	N/A	0.003	0.000	N/A	N/L
9	0.099	0.013	N/A	0.099	0.019	N/A	N/L
10	0.002	0.000	N/A	0.003	0.000	N/A	N/L
11	0.093	0.009	N/A	0.094	0.014	N/A	N/L
12	0.002	0.000	N/A	0.003	0.000	N/A	N/L
13	0.087	0.008	N/A	0.087	0.012	N/A	N/L
14	0.002	0.000	N/A	0.002	0.000	N/A	N/L
15	0.080	0.007	N/A	0.080	0.010	N/A	N/L
16	0.002	0.000	N/A	0.002	0.000	N/A	N/L
17	0.072	0.006	N/A	0.073	0.009	N/A	N/L
18	0.002	0.000	N/A	0.002	0.000	N/A	N/L
19	0.065	0.005	N/A	0.065	0.008	N/A	N/L
20	0.001	0.000	N/A	0.002	0.000	N/A	N/L
21	0.057	0.005	N/A	0.057	0.007	N/A	N/L
22	0.001	0.000	N/A	0.002	0.000	N/A	N/L
23	0.049	0.004	N/A	0.049	0.006	N/A	N/L
24	0.001	0.000	N/A	0.002	0.000	N/A	N/L
25	0.041	0.004	N/A	0.042	0.006	N/A	N/L
26	0.001	0.000	N/A	0.001	0.000	N/A	N/L
27	0.034	0.004	N/A	0.035	0.006	N/A	N/L
28	0.001	0.000	N/A	0.001	0.000	N/A	N/L
29	0.028	0.003	N/A	0.028	0.005	N/A	N/L
30	0.001	0.000	N/A	0.001	0.000	N/A	N/L
31	0.021	0.003	N/A	0.022	0.005	N/A	N/L
32	0.001	0.000	N/A	0.001	0.000	N/A	N/L
33	0.016	0.003	N/A	0.016	0.004	N/A	N/L
34	0.001	0.000	N/A	0.001	0.000	N/A	N/L
35	0.011	0.003	N/A	0.011	0.004	N/A	N/L
36	0.000	0.000	N/A	0.001	0.000	N/A	N/L
37	0.007	0.003	N/A	0.007	0.004	N/A	N/L
38	0.000	0.000	N/A	0.001	0.000	N/A	N/L
39	0.004	0.003	N/A	0.004	0.004	N/A	N/L
40	0.000	0.000	N/A	0.000	0.000	N/A	N/L

Note: The EUT power level is below 75.0 Watts and therefore has no defined limits

Voltage Source Verification Data (Run time)

E.U.T	LCD Monitor	Model Name	238LM00009
Temperature	26 °C	Relative Humidity	45%
Test Voltage	AC 230V/50Hz		
Test Mode	HDMI 2 2560*1440 144Hz (715G8055)		

Highest parameter values during test:

Voltage (Vrms):	230.05	Frequency(Hz):	50.00
I_Peak (Amps):	1.732	I_RMS (Amps):	0.323
I_Fund (Amps):	0.116	Crest Factor:	5.373
Power (Watts):	25.8	Power Factor:	0.349

Harm#	Harmonics V-rms	Limit V-rms	% of Limit	Status
2	0.140	0.460	30.51	OK
3	0.624	2.070	30.13	OK
4	0.060	0.460	13.08	OK
5	0.074	0.920	8.02	OK
6	0.024	0.460	5.30	OK
7	0.074	0.690	10.68	OK
8	0.016	0.460	3.45	OK
9	0.028	0.460	6.19	OK
10	0.020	0.460	4.39	OK
11	0.067	0.230	29.15	OK
12	0.014	0.230	6.25	OK
13	0.056	0.230	24.42	OK
14	0.009	0.230	4.00	OK
15	0.061	0.230	26.66	OK
16	0.012	0.230	5.07	OK
17	0.058	0.230	25.11	OK
18	0.013	0.230	5.51	OK
19	0.063	0.230	27.47	OK
20	0.017	0.230	7.57	OK
21	0.057	0.230	24.72	OK
22	0.012	0.230	5.02	OK
23	0.058	0.230	25.40	OK
24	0.008	0.230	3.42	OK
25	0.047	0.230	20.49	OK
26	0.009	0.230	4.11	OK
27	0.046	0.230	19.98	OK
28	0.008	0.230	3.47	OK
29	0.034	0.230	14.95	OK
30	0.007	0.230	2.89	OK
31	0.034	0.230	14.77	OK
32	0.009	0.230	3.77	OK
33	0.025	0.230	10.84	OK
34	0.010	0.230	4.41	OK
35	0.023	0.230	9.91	OK
36	0.013	0.230	5.65	OK
37	0.013	0.230	5.80	OK
38	0.014	0.230	6.22	OK
39	0.013	0.230	5.75	OK
40	0.015	0.230	6.61	OK

4.4 VOLTAGE CHANGES, VOLTAGE FLUCTUATIONS AND FLICKER TEST

4.4.1 LIMITS

Tests	Limits	Descriptions
	EN 61000-3-3	
Pst	≤ 1.0 , $T_p= 10$ min.	Short Term Flicker Indicator
Plt	≤ 0.65 , $T_p=2$ hr.	Long Term Flicker Indicator
dc	$\leq 3.3\%$	Relative Steady-State V-Chang
dmax	$\leq 4\%$	Maximum Relative V-change
d (t)	$\leq 3.3\%$ for > 500 ms	Relative V-change characteristic

4.4.2 MEASUREMENT INSTRUMENTS LIST

Item	Kind of Equipment	Manufacturer	Type No.	Serial No.	Calibrated until
1	Harmonic & Flicker	California	PACS-1	72344	Sep. 06, 2016
2	Power Source	California	3001iX	56309	Sep. 06, 2016
3	Measurement Software	California	CTS4.0 Version 4.9	N/A	N/A

Remark: "N/A" denotes no model name, no serial no. or no calibration specified.

All calibration period of equipment list is one year.

4.4.3 TEST PROCEDURE

- a. Tests was performed according to the Test Conditions/Assessment of Voltage Fluctuations specified in EN 61000-3-3 depend on which standard adopted for compliance measurement.
- b. All types of harmonic current and/or voltage fluctuation in this report are assessed by direct measurement using flicker-meter.

4.4.4 DEVIATION FROM TEST STANDARD

No deviation

4.4.5 TESTSETUP

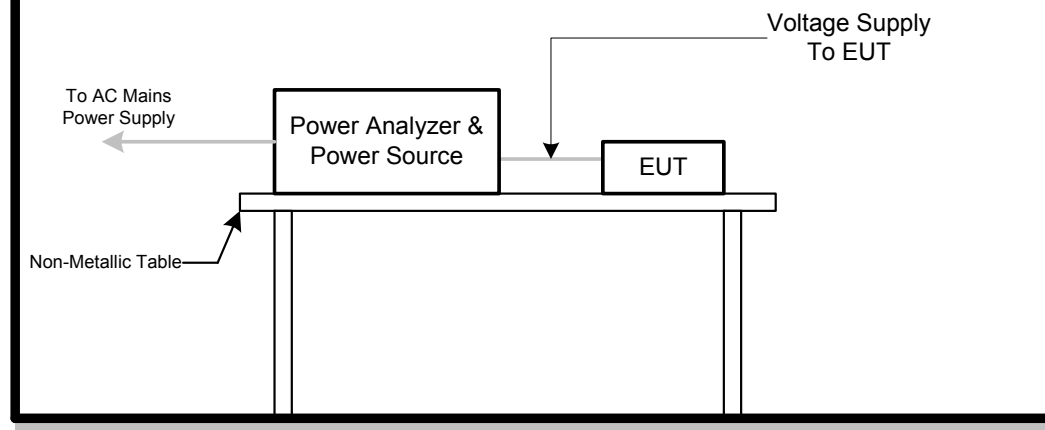

4.4.6 EUT OPERATING CONDITIONS

The EUT tested system was configured as the statements of **4.1.6** unless otherwise a special operating condition is specified in the follows during the testing.

4.4.7 TEST RESULTS

E.U.T	LCD Monitor	Model Name	238LM00009
Temperature	26 °C	Relative Humidity	45%
Test Voltage	AC 230V/50Hz		
Test Mode	HDMI 2560*1440 60Hz (715G8083)		

Pst; and limit line

European Limits

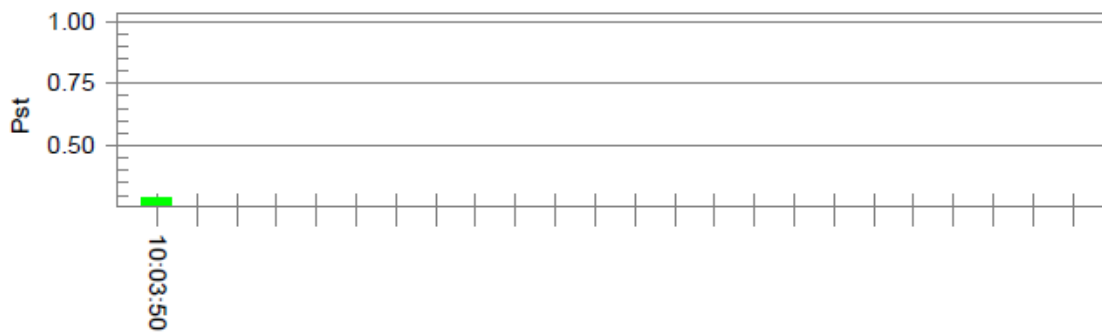

Plt and limit line

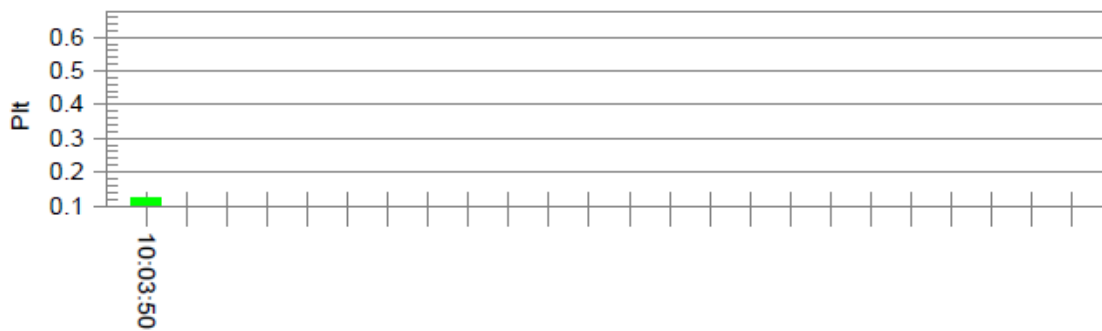

Parameter values recorded during the test:

Vrms at the end of test (Volt):	230.01		
Highest dt (%):	0.00	Test limit (%):	N/A
T-max (mS):	0	Test limit (mS):	500.0
Highest dc (%):	0.00	Test limit (%):	3.30
Highest dmax (%):	-0.04	Test limit (%):	4.00
Highest Pst (10 min. period):	0.288	Test limit:	1.000
Highest Plt (2 hr. period):	0.126	Test limit:	0.650

E.U.T	LCD Monitor	Model Name	238LM00009
Temperature	26 °C	Relative Humidity	45%
Test Voltage	AC 230V/50Hz		
Test Mode	HDMI 2 2560*1440 144Hz (715G8055)		

Pst, and limit line

European Limits



Plt and limit line



Parameter values recorded during the test:

Vrms at the end of test (Volt):	229.98		
Highest dt (%):	0.00	Test limit (%):	N/A N/A
T-max (mS):	0	Test limit (mS):	500.0 Pass
Highest dc (%):	0.00	Test limit (%):	3.30 Pass
Highest dmax (%):	-0.05	Test limit (%):	4.00 Pass
Highest Pst (10 min. period):	0.279	Test limit:	1.000 Pass
Highest Plt (2 hr. period):	0.122	Test limit:	0.650 Pass

5. EMC IMMUNITY TEST

5.1 STANDARD COMPLIANCE/SERVIRITY LEVEL/CRITERIA

Tests Standard No.	TEST SPECIFICATION Level	Test Mode Test Ports	Criterion
Electrostatic discharge immunity EN 61000-4-2	±8 kV air discharge ±4 kV contact discharge	Direct Mode	B
	±4 kV HCP discharge ±4 kV VCP discharge	Indirect Mode	B
Radiated, radio-frequency, electromagnetic field immunity EN 61000-4-3	80 MHz to 1000 MHz 3 V/m (unmodulated, r.m.s), 1 kHz, 80%, AM modulated	Enclosure	A
Electrical fast transient/burst immunity EN 61000-4-4	±1.0kV(peak) 5/50ns Tr/Th 5 kHz Repetition Freq.	Power Supply Port	B
	±0.5 kV(peak) 5/50ns Tr/Th 5 kHz Repetition Freq.	CTL/Signal Data Line Port	B
Surge immunity EN 61000-4-5	±0.5, 1 kV(5P/5N) 1.2/50(8/20) Tr/Th µs	AC Power Port L-N	B
	±2 kV(5P/5N) 1.2/50(8/20) Tr/Th µs	AC Power Port L-PE/N-PE	B
	±0.5 kV(5P/5N) 1.2/50(8/20) Tr/Th µs	DC Power Port	B
	±1 kV(5P/5N) 10/700 or 1.2/50 Tr/Th µs	Signal/Telecommuni- cation Ports	C
Immunity to conducted disturbances, induced by radio-frequency fields EN 61000-4-6	0.15 MHz to 80 MHz 3 V (unmodulated, r.m.s), 1 kHz 80%, AM Modulated 150Ω source impedance	CTL/Signal Port	A
	0.15 MHz to 80 MHz 3 V (unmodulated, r.m.s), 1 kHz 80%, AM Modulated 150Ω source impedance	AC Power Port	A
	0.15 MHz to 80 MHz 3 V (unmodulated, r.m.s), 1 kHz 80%, AM Modulated 150Ω source impedance	DC Power Port	A
Power frequency magnetic field immunity EN 61000-4-8	50/60 Hz, 1 A/m	Enclosure	A
Voltage dips, short interruptions and voltage variations immunity EN 61000-4-11	Voltage Dips > 95%	AC Power Port	B
	Voltage Dips 30%		C
	Voltage Interruptions > 95%		C

5.2 GENERAL PERFORMANCE CRITERIA

According to **EN55024** standard, the general performance criteria as following:

<p>Criterion A</p>	<p>The equipment shall continue to operate as intended without operator intervention. No degradation of performance or loss of function is allowed below a performance level specified by the manufacturer when the equipment is used as intended. The performance level may be replaced by a permissible loss of performance.</p> <p>If the minimum performance level or the permissible performance loss is not specified by the manufacturer, then either of these may be derived from the product description and documentation, and by what the user product description and documentation, and by what the user may reasonably expect from the equipment if used as intended.</p>
<p>Criterion B</p>	<p>After the test, the equipment shall continue to operate as intended without operator intervention. No degradation of performance or loss of function is allowed, after the application of the phenomenon below a performance level specified by the manufacturer, when the equipment is used as intended. The performance level may be replaced by a permissible loss of performance.</p> <p>During the test, degradation of performance is allowed. However, no change of operating state if stored data allowed to persist after the test. If the minimum performance level (or the permissible performance loss) is not specified by the manufacturer, then either of these may be derived from the product description and documentation, and by what the user may reasonably expect from the equipment if used as intended.</p>
<p>Criterion C</p>	<p>Loss of function is allowed, provided the function is self-recoverable, or can be restored by the operation of the controls by the user in accordance with the manufacturer's instructions.</p> <p>Functions, and/or information stored in non-volatile memory, or protected by a battery backup, shall not be lost.</p>

5.3 GENERAL PERFORMANCE CRITERIA TEST SETUP

The EUT tested system was configured as the statements of **4.1.6** unless otherwise a special operating condition is specified in the follows during the testing.

5.4 ELECTROSTATIC DISCHARGE IMMUNITY TEST (ESD)

5.4.1 TEST SPECIFICATION

Basic Standard	EN 61000-4-2
Discharge Impedance	330 ohm / 150 pF
Required Performance	B
Discharge Voltage	Air Discharge: ± 2 kV, ± 4 kV, ± 8 kV (Direct) Contact Discharge: ± 2 kV, ± 4 kV (Direct/Indirect)
Polarity	Positive & Negative
Number of Discharge	Air Discharge: min. 20 times at each test point Contact Discharge: min. 200 times in total
Discharge Mode	Single Discharge
Discharge Period	1 second minimum

5.4.2 MEASUREMENT INSTRUMENTS

Item	Kind of Equipment	Manufacturer	Type No.	Serial No.	Calibrated until
1	ESD Generator	TESEQ AG	NSG 437	450	Oct. 28, 2016

Remark: "N/A" denotes no model name, no serial no. or no calibration specified.

All calibration period of equipment list is one year.

5.4.3 TEST PROCEDURE

The test generator necessary to perform direct and indirect application of discharges to the EUT in the following manner:

- a. Contact discharge was applied to conductive surfaces (Direct) and coupling planes (Indirect) of the EUT.

During the test, it was performed with single discharges. For the single discharge time between successive single discharges was at least 1 second. The EUT shall be exposed to at least 200 discharges, 100 each at negative and positive polarity, at a minimum of four test points. One of the test points shall be subjected to at least 50 indirect discharges to the center of the front edge of the horizontal coupling plane. The remaining three test points shall each receive at least 50 direct contact discharges.

If no direct contact test points are available, then at least 200 indirect discharges shall be applied in the indirect mode. Test shall be performed at a maximum repetition rate of one discharge per second.

Vertical Coupling Plane (VCP):

The coupling plane, of dimensions 0.5m x 0.5m, is placed parallel to, and positioned at a distance 0.1m from, the EUT, with the Discharge Electrode touching the coupling plane.

The four faces of the EUT will be performed with electrostatic discharge.

Horizontal Coupling Plane (HCP):

The coupling plane is placed under to the EUT. The generator shall be positioned vertically at a distance of 0.1m from the EUT, with the Discharge Electrode touching the coupling plane.

The four faces of the EUT will be performed with electrostatic discharge.

- b. Air discharges at insulation surfaces of the EUT.

It was at least ten single discharges with positive and negative at the same selected point.

5.4.4 DEVIATION FROM TEST STANDARD

No deviation

5.4.5 TEST SETUP

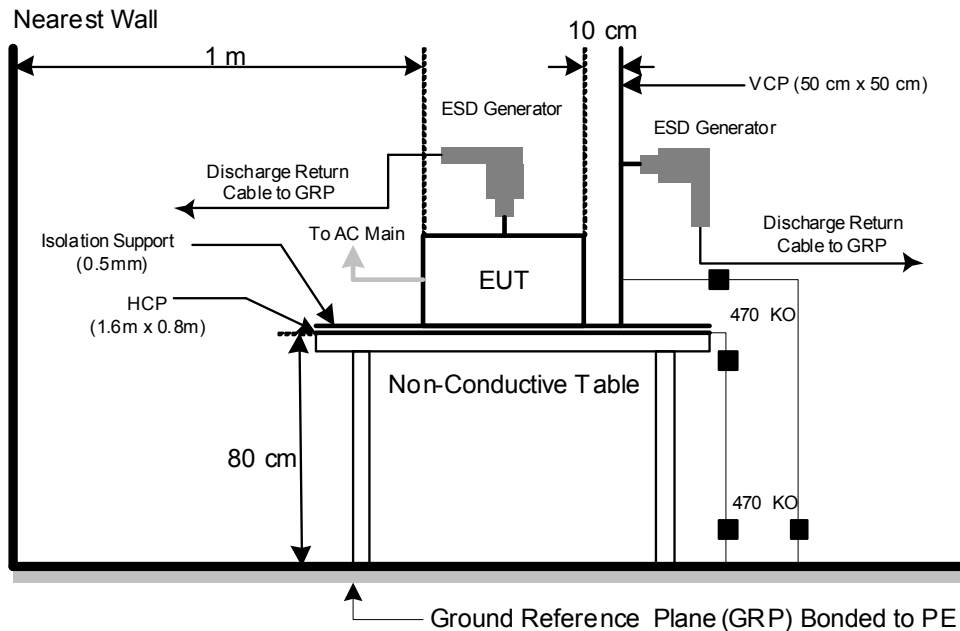

Note:

TABLE-TOP EQUIPMENT

The configuration consisted of a wooden table 0.8 meters high standing on the Ground Reference Plane. The GRP consisted of a sheet of aluminum at least 0.25mm thick, and 2.5 meters square connected to the protective grounding system. A Horizontal Coupling Plane (1.6m x 0.8m) was placed on the table and attached to the GRP by means of a cable with 940k total impedance. The equipment under test was installed in a representative system as described in EN 61000-4-2, and its cables were placed on the HCP and isolated by an insulating support of 0.5mm thickness. A distance of 1-meter minimum was provided between the EUT and the walls of the laboratory and any other metallic structure.

FLOOR-STANDING EQUIPMENT

The equipment under test was installed in a representative system as described in EN 61000-4-2, and its cables were isolated from the Ground Reference Plane by an insulating support of 0.1-meter thickness. The GRP consisted of a sheet of aluminum that is at least 0.25mm thick, and 2.5 meters square connected to the protective grounding system and extended at least 0.5 meters from the EUT on all sides.

5.4.6 TEST RESULTS

EUT	LCD Monitor	Model Name	238LM00009
Temperature	26°C	Relative Humidity	45%
Pressure	1010 hPa	Test Voltage	AC 230V/50Hz
Test Mode	HDMI 2560*1440 60Hz (715G8083)		

Mode	Air Discharge								Contact Discharge							
	2 kV		4 kV		8 kV		- kV		2 kV		4 kV		- kV		- kV	
Location	P	N	P	N	P	N	P	N	P	N	P	N	P	N	P	N
1	A	A	A	A	A	A	-	-	B	B	B	B	-	-	-	-
2	A	A	A	A	A	A	-	-	-	-	-	-	-	-	-	-
3	A	A	A	A	A	A	-	-	-	-	-	-	-	-	-	-
4	A	A	A	A	A	A	-	-	-	-	-	-	-	-	-	-
5	A	A	A	A	A	A	-	-	-	-	-	-	-	-	-	-
6	A	A	A	A	A	A	-	-	-	-	-	-	-	-	-	-
7	A	A	A	A	A	A	-	-	-	-	-	-	-	-	-	-
8	A	A	A	A	A	A	-	-	-	-	-	-	-	-	-	-
9	A	A	A	A	A	A	-	-	-	-	-	-	-	-	-	-
10	A	A	A	A	A	A	-	-	-	-	-	-	-	-	-	-
11	A	A	A	A	A	A	-	-	-	-	-	-	-	-	-	-
12	A	A	A	A	A	A	-	-	-	-	-	-	-	-	-	-
13	A	A	A	A	A	A	-	-	-	-	-	-	-	-	-	-
Criterion	B								B							
Result	A								B							
Judgment	PASS								PASS							

Mode	HCP Discharge								VCP Discharge							
	2 kV		4 kV		- kV		- kV		2 kV		4 kV		- kV		- kV	
Location	P	N	P	N	P	N	P	N	P	N	P	N	P	N	P	N
1	A	A	A	A	-	-	-	-	A	A	A	A	-	-	-	-
2	A	A	A	A	-	-	-	-	A	A	A	A	-	-	-	-
3	A	A	A	A	-	-	-	-	A	A	A	A	-	-	-	-
4	A	A	A	A	-	-	-	-	A	A	A	A	-	-	-	-
Criterion	B								B							
Result	A								A							
Judgment	PASS								PASS							

Note:

- 1) P/N denotes the Positive/Negative polarity of the output voltage.
- 2) Test condition:
Direct/Indirect (HCP/VCP) discharges: Minimum 25 times (Positive/Negative) at each point.
Air discharges: Minimum 10 times (Positive/Negative) at each point.
- 3) Test location(s) in which discharge (Air and contact discharge) to be applied illustrated by photos shown in next page(s)
- 4) The Indirect (HCP/VCP) discharges description of test point as following:
1. left side; 2.right side; 3.front side; 4.rear side.
- 5) N/A - denotes test is not applicable in this test report
- 6) Criterion A: No observation of any performance degradation.
- 7) Criterion B: Some degradation of performance is observed but the equipment continues to operate as intended.
- 8) Criterion C: Loss of functionality, but self-recoverable by user, without loss of information or settings.

PHOTO(S) SHOWN THE LOCATION(S) OF ESD EVALUATED

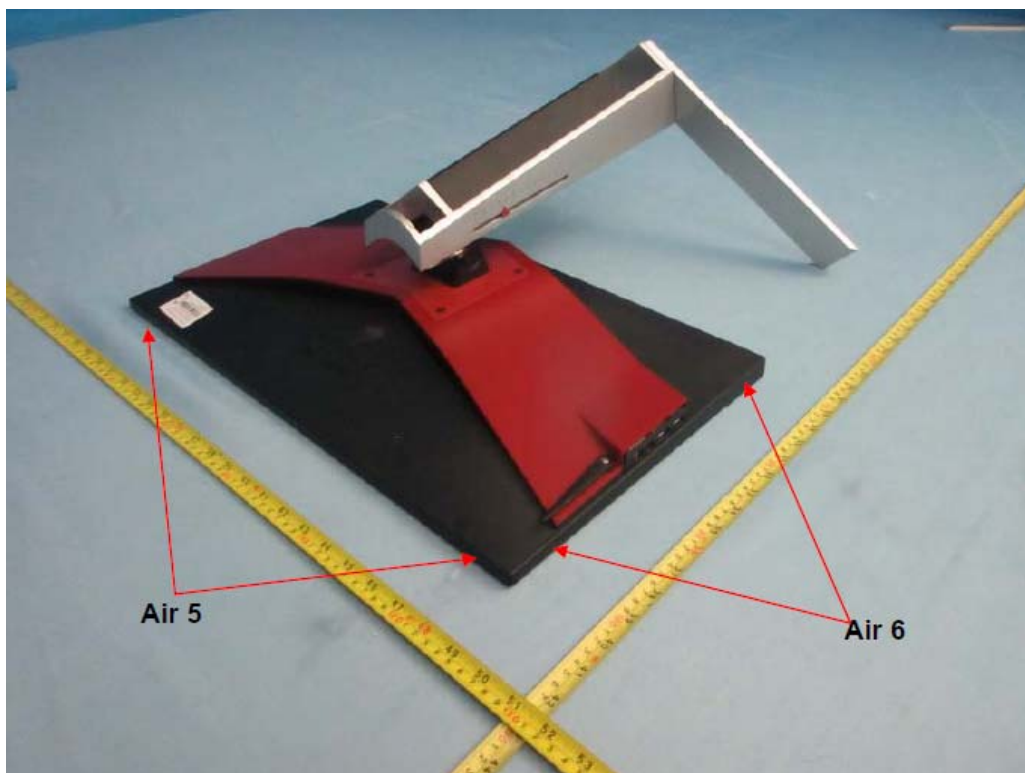
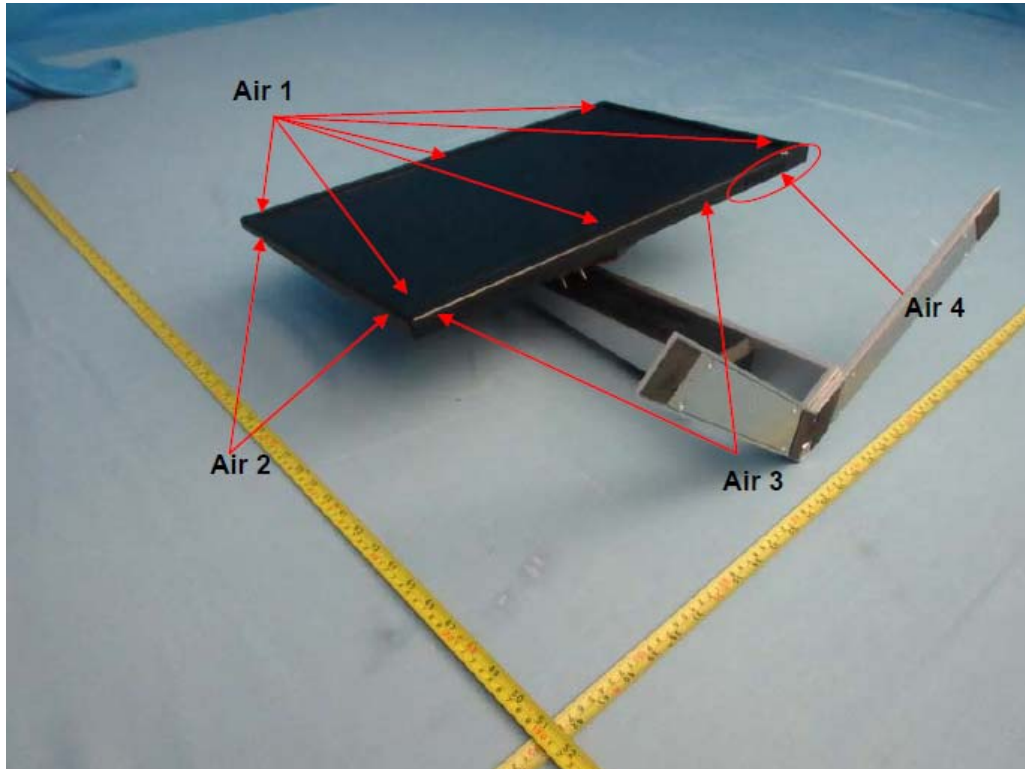

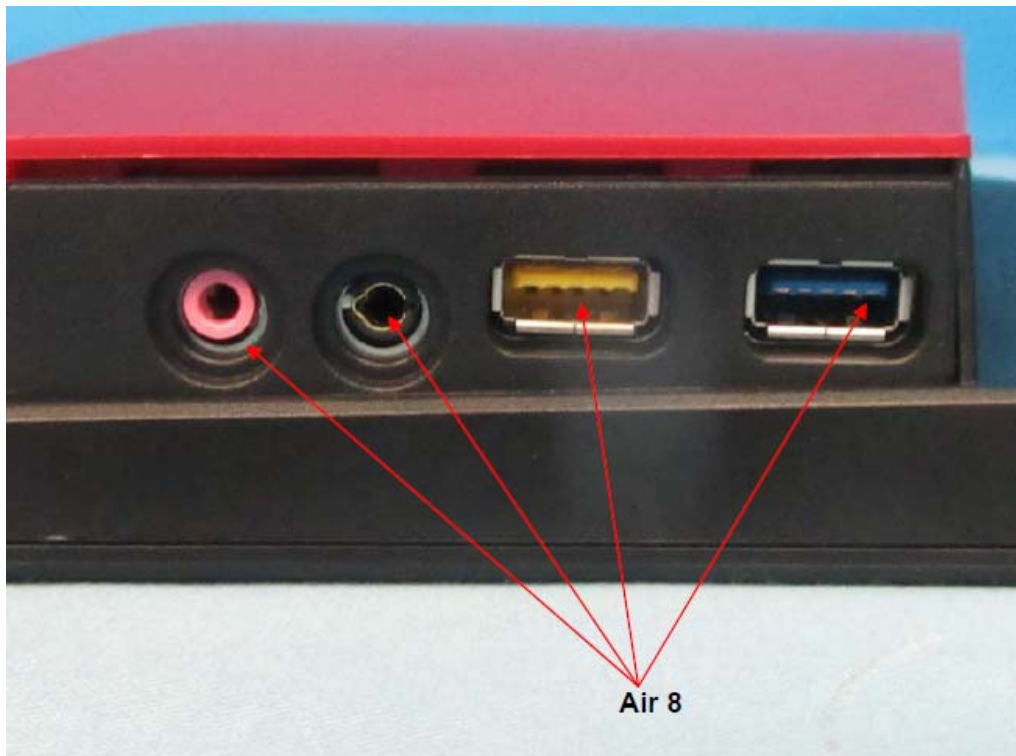
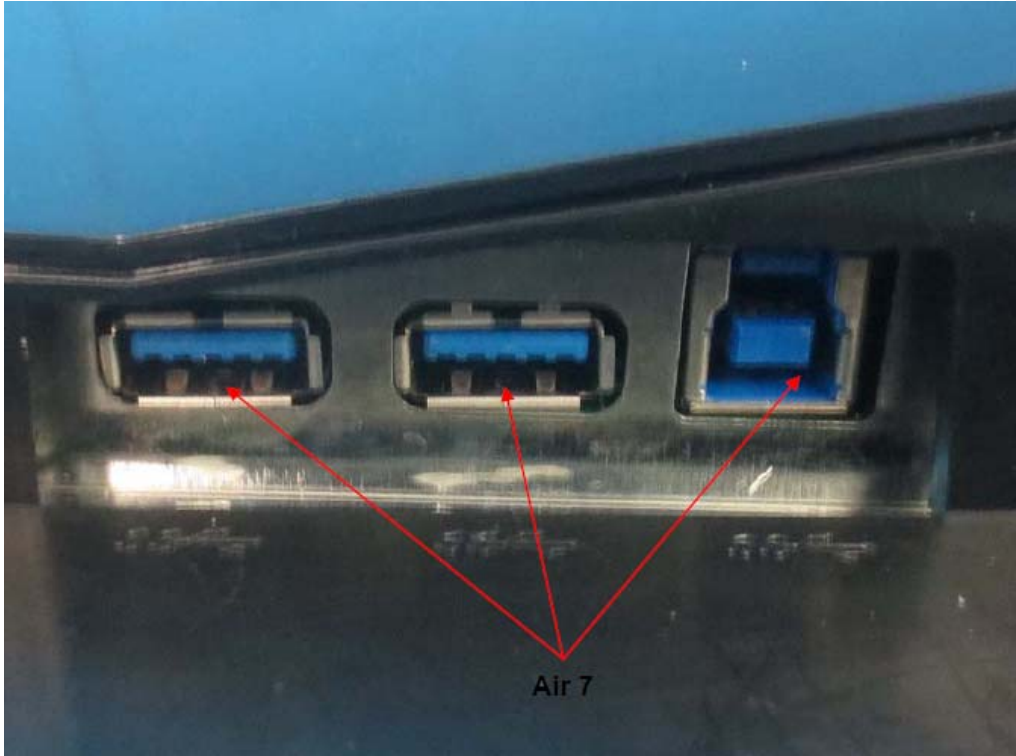

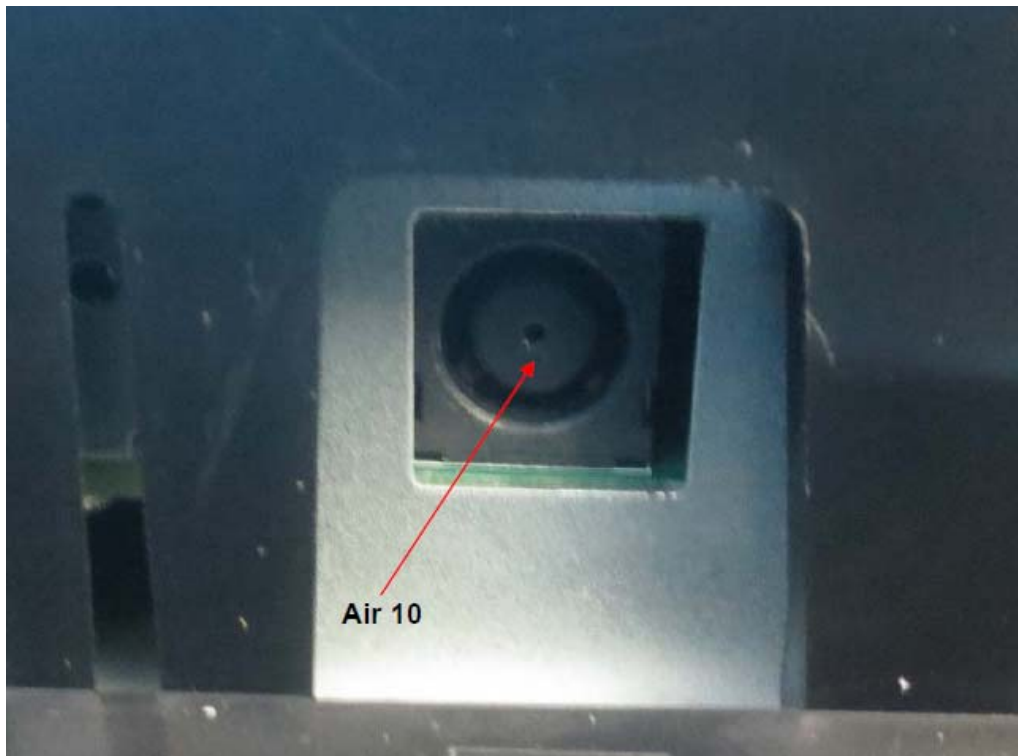
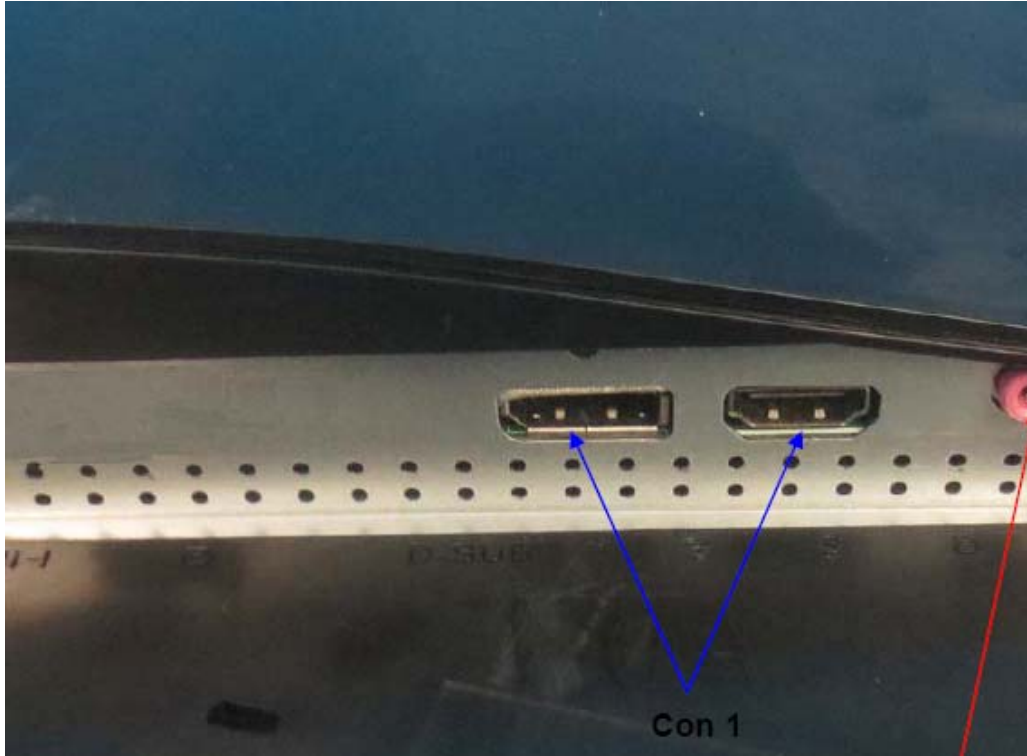

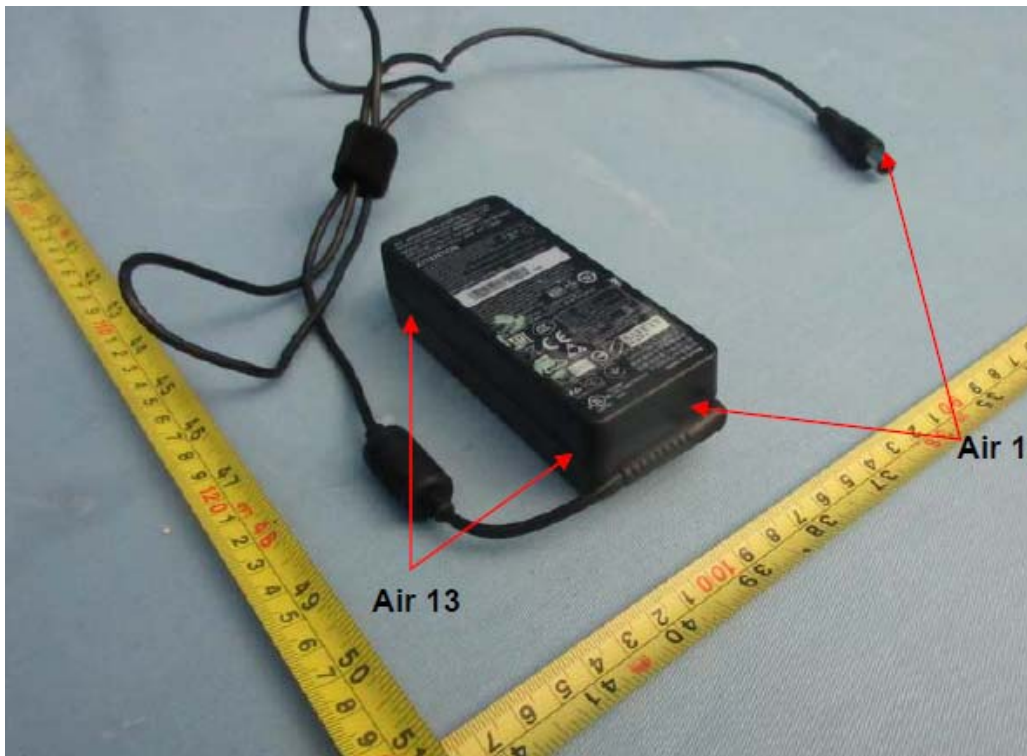
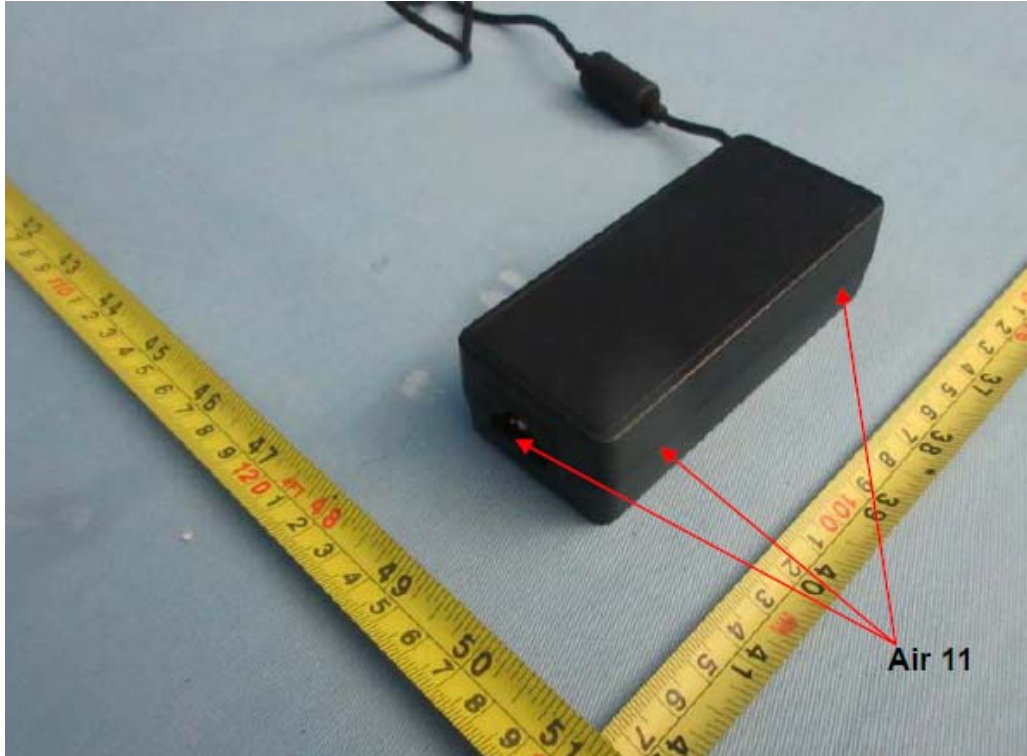

EUT	LCD Monitor	Model Name	238LM00009
Temperature	26°C	Relative Humidity	45%
Pressure	1010 hPa	Test Voltage	AC 230V/50Hz
Test Mode	HDMI 2 2560*1440 144Hz (715G8055)		

Mode	Air Discharge								Contact Discharge							
	2 kV		4 kV		8 kV		- kV		2 kV		4 kV		- kV		- kV	
Location	P	N	P	N	P	N	P	N	P	N	P	N	P	N	P	N
1	A	A	A	A	A	A	-	-	B	B	B	B	-	-	-	-
2	A	A	A	A	A	A	-	-	B	B	B	B	-	-	-	-
3	A	A	A	A	A	A	-	-	-	-	-	-	-	-	-	-
4	A	A	A	A	A	A	-	-	-	-	-	-	-	-	-	-
5	A	A	A	A	A	A	-	-	-	-	-	-	-	-	-	-
6	A	A	A	A	A	A	-	-	-	-	-	-	-	-	-	-
7	A	A	A	A	A	A	-	-	-	-	-	-	-	-	-	-
8	A	A	A	A	A	A	-	-	-	-	-	-	-	-	-	-
9	A	A	A	A	A	A	-	-	-	-	-	-	-	-	-	-
10	A	A	A	A	A	A	-	-	-	-	-	-	-	-	-	-
11	A	A	A	A	A	A	-	-	-	-	-	-	-	-	-	-
12	A	A	A	A	A	A	-	-	-	-	-	-	-	-	-	-
13	A	A	A	A	A	A	-	-	-	-	-	-	-	-	-	-
Criterion	B								B							
Result	A								B							
Judgment	PASS								PASS							

Mode	HCP Discharge								VCP Discharge							
	2 kV		4 kV		- kV		- kV		2 kV		4 kV		- kV		- kV	
Location	P	N	P	N	P	N	P	N	P	N	P	N	P	N	P	N
1	A	A	A	A	-	-	-	-	A	A	A	A	-	-	-	-
2	A	A	A	A	-	-	-	-	A	A	A	A	-	-	-	-
3	A	A	A	A	-	-	-	-	A	A	A	A	-	-	-	-
4	A	A	A	A	-	-	-	-	A	A	A	A	-	-	-	-
Criterion	B								B							
Result	A								A							
Judgment	PASS								PASS							

Note:

- 1) P/N denotes the Positive/Negative polarity of the output voltage.
- 2) Test condition:
Direct/Indirect (HCP/VCP) discharges: Minimum 25 times (Positive/Negative) at each point.
Air discharges: Minimum 10 times (Positive/Negative) at each point.
- 3) Test location(s) in which discharge (Air and contact discharge) to be applied illustrated by photos shown in next page(s)
- 4) The Indirect (HCP/VCP) discharges description of test point as following:
1. left side; 2.right side; 3.front side; 4.rear side.
- 5) N/A - denotes test is not applicable in this test report
- 6) Criterion A: No observation of any performance degradation.
- 7) Criterion B: Some degradation of performance is observed but the equipment continues to operate as intended.
- 8) Criterion C: Loss of functionality, but self-recoverable by user, without loss of information or settings.

PHOTO(S) SHOWN THE LOCATION(S) OF ESD EVALUATED

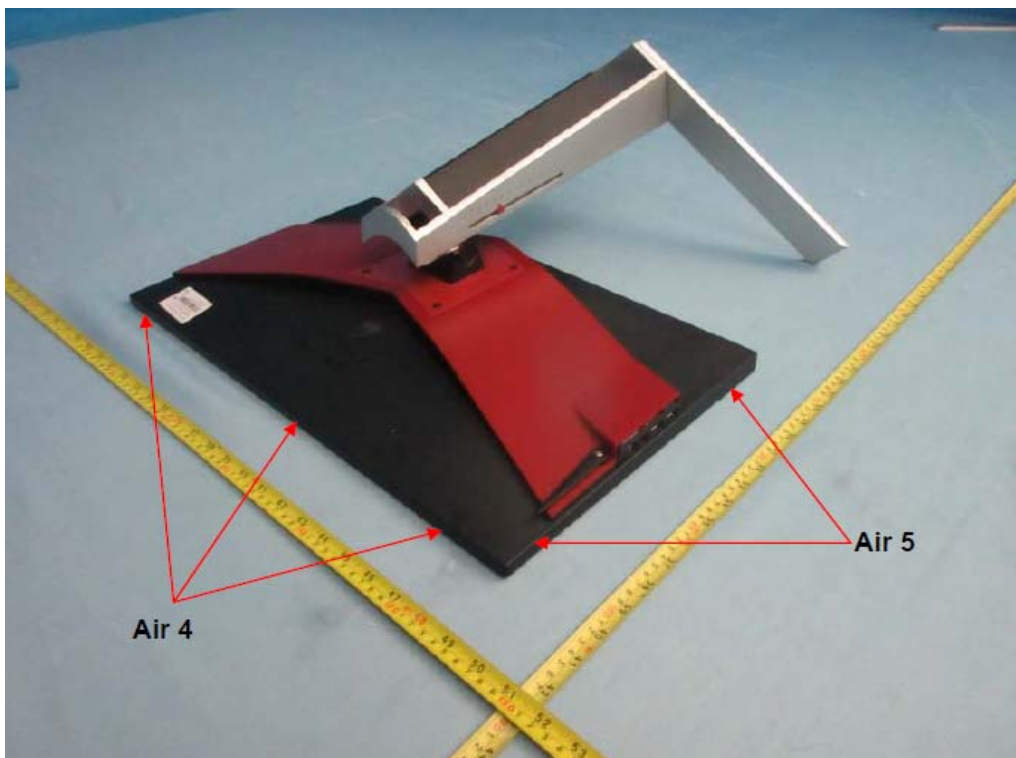
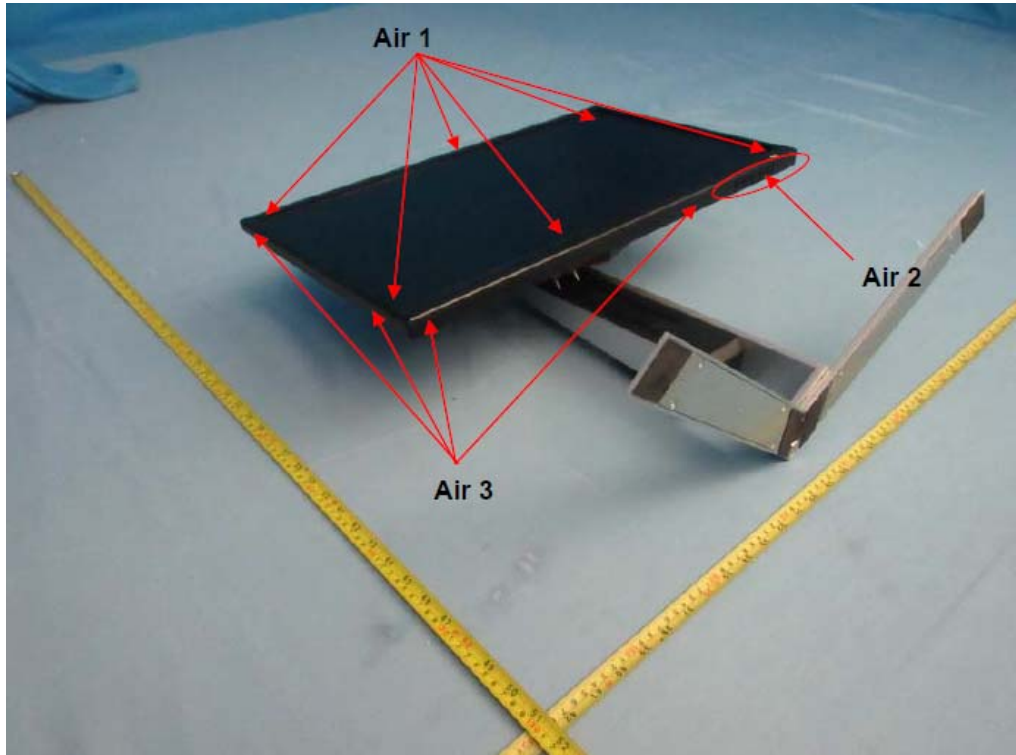

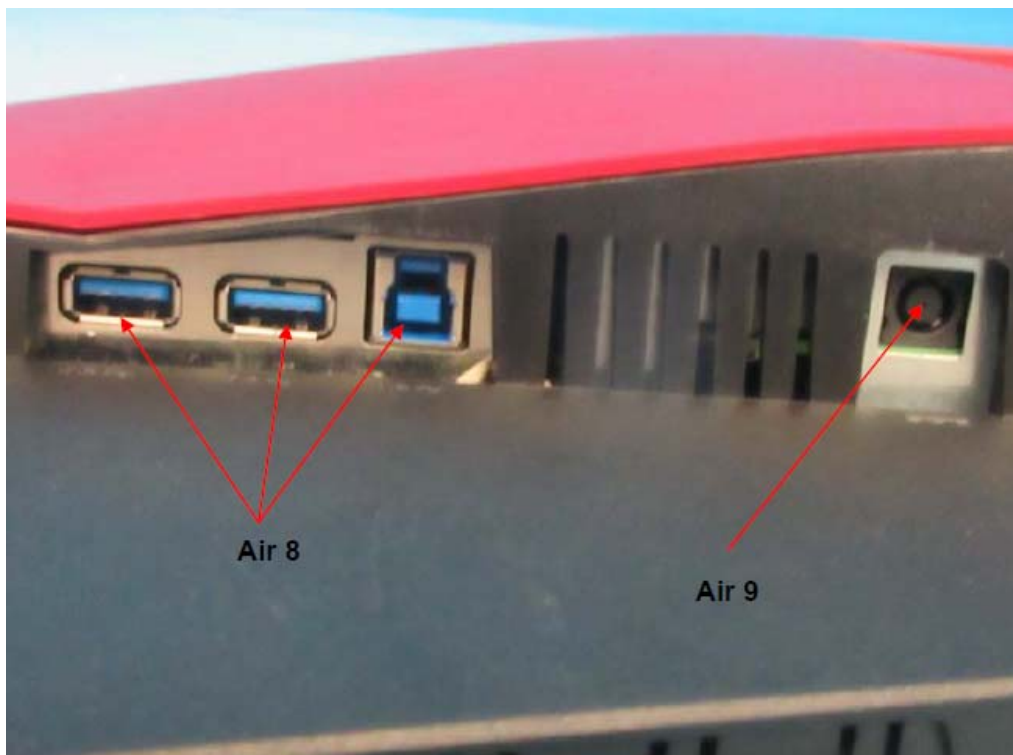
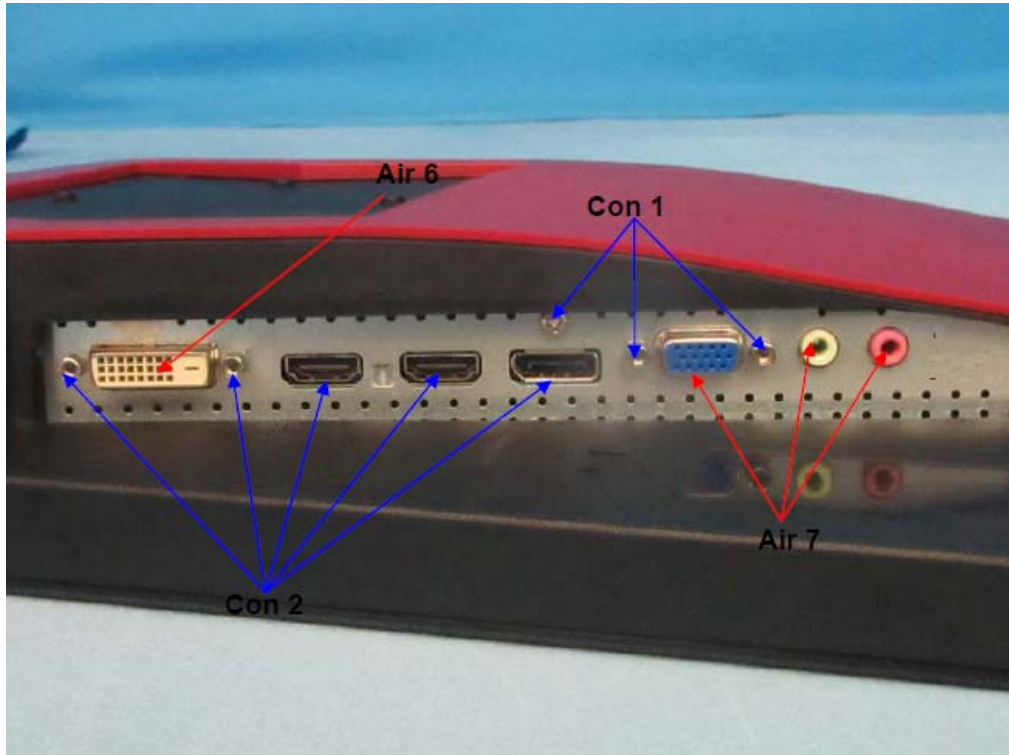

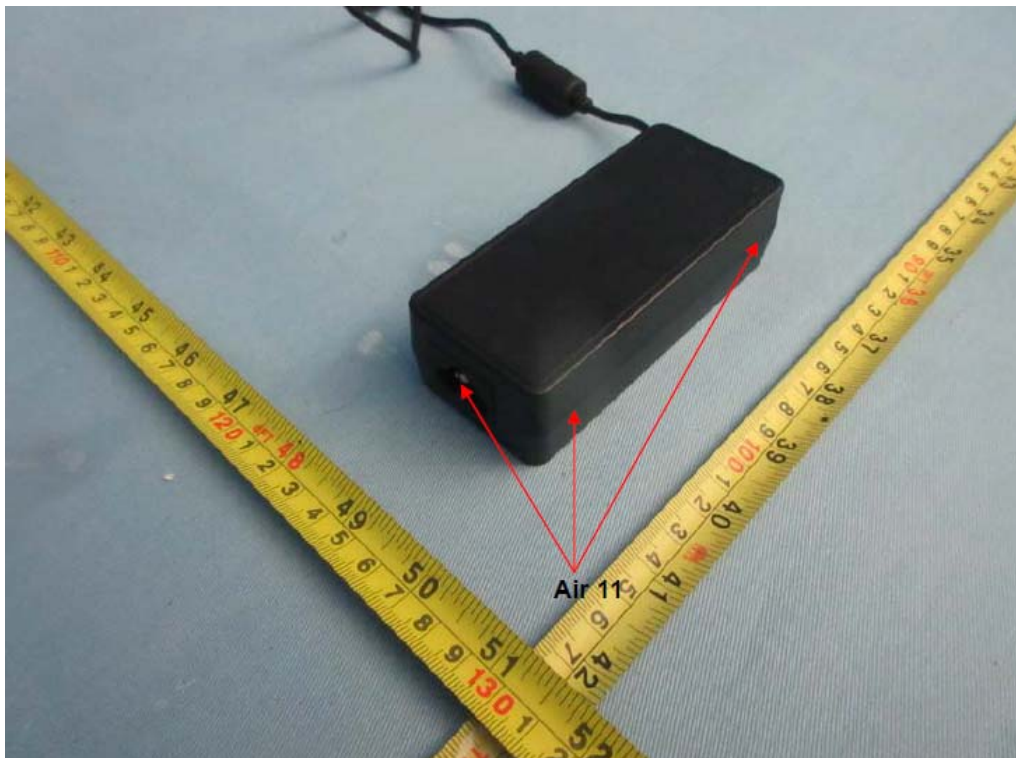

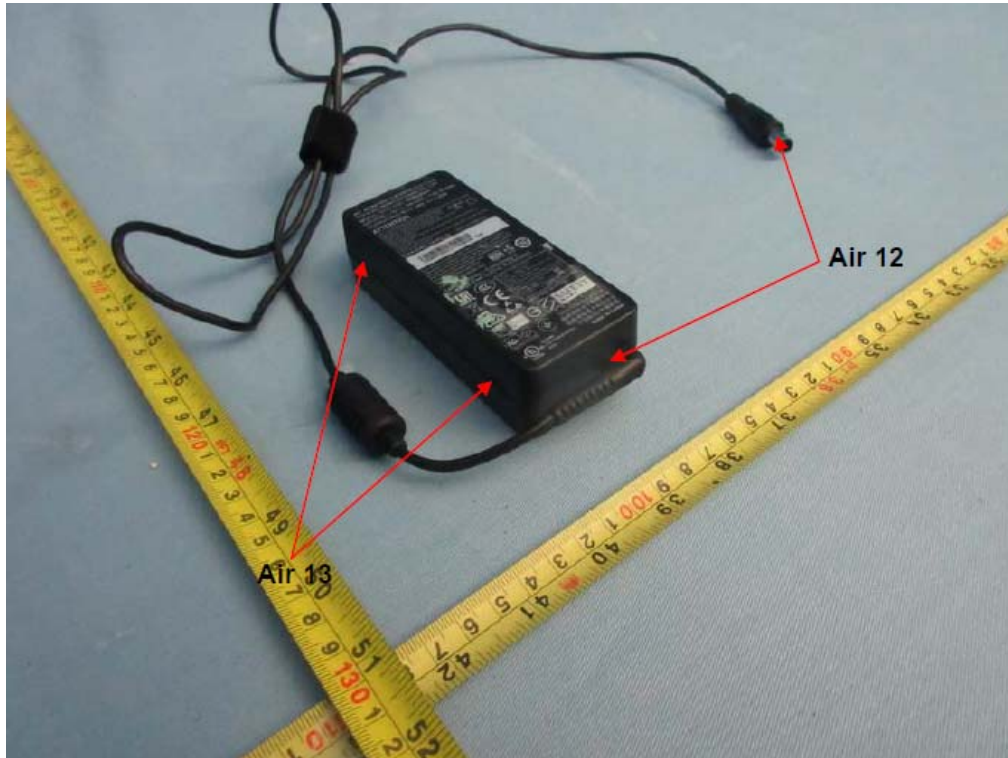

5.5 RADIATED, RADIO-FREQUENCY, ELECTROMAGNETIC FIELD IMMUNITY TEST (RS)

5.5.1 TEST SPECIFICATION

Basic Standard	EN 61000-4-3
Required Performance	A
Frequency Range	80 MHz - 1000 MHz
Field Strength	3 V/m (unmodulated, r.m.s)
Modulation	1 kHz Sine Wave, 80%, AM Modulation
Frequency Step	1% of fundamental
Polarity of Antenna	Horizontal and Vertical
Test Distance	3 m
Antenna Height	1.5 m
Dwell Time	at least 3 seconds

5.5.2 MEASUREMENT INSTRUMENTS

Item	Kind of Equipment	Manufacturer	Type No.	Serial No.	Calibrated until
1	Digital Signal Generator	HP	ESG-D3000A	US36260188	Mar. 27, 2017
2	Antenna	ETS	3142C	00047662	Mar. 27, 2017
3	Power amplifier	MILMEGA	80RF1000-250	N/A	Nov. 02, 2016
4	Amplifier	AR	50S1G4A	326720	Mar. 27, 2017
5	Measurement Software	TOYO	IM5/R Ver 3.8.050	N/A	N/A

Remark: "N/A" denotes no model name, no serial no. or no calibration specified.

All calibration period of equipment list is one year.

5.5.3 TEST PROCEDURE

The EUT and support equipment, which are placed on a table that is 0.8 meter above ground and the testing was performed in a fully-anechoic chamber.

The testing distance from antenna to the EUT was 3 meters.

The other condition as following manner:

- a. The field strength level was 3 V/m (unmodulated, r.m.s).
- b. The frequency range is swept from 80 MHz to 1000 MHz, with the signal 80% amplitude modulated with a 1 kHz sine wave. The rate of sweep did not exceed 1.5×10^{-3} decade/s. Where the frequency range is swept incrementally, the step size was 1% of fundamental.
- c. The dwell time at each frequency shall be not less than the time necessary for the EUT to be able to respond.
- d. The test was performed with the EUT exposed to both vertically and horizontally polarized fields on each of the four sides.

5.5.4 DEVIATION FROM TEST STANDARD

No deviation

5.5.5 TEST SETUP

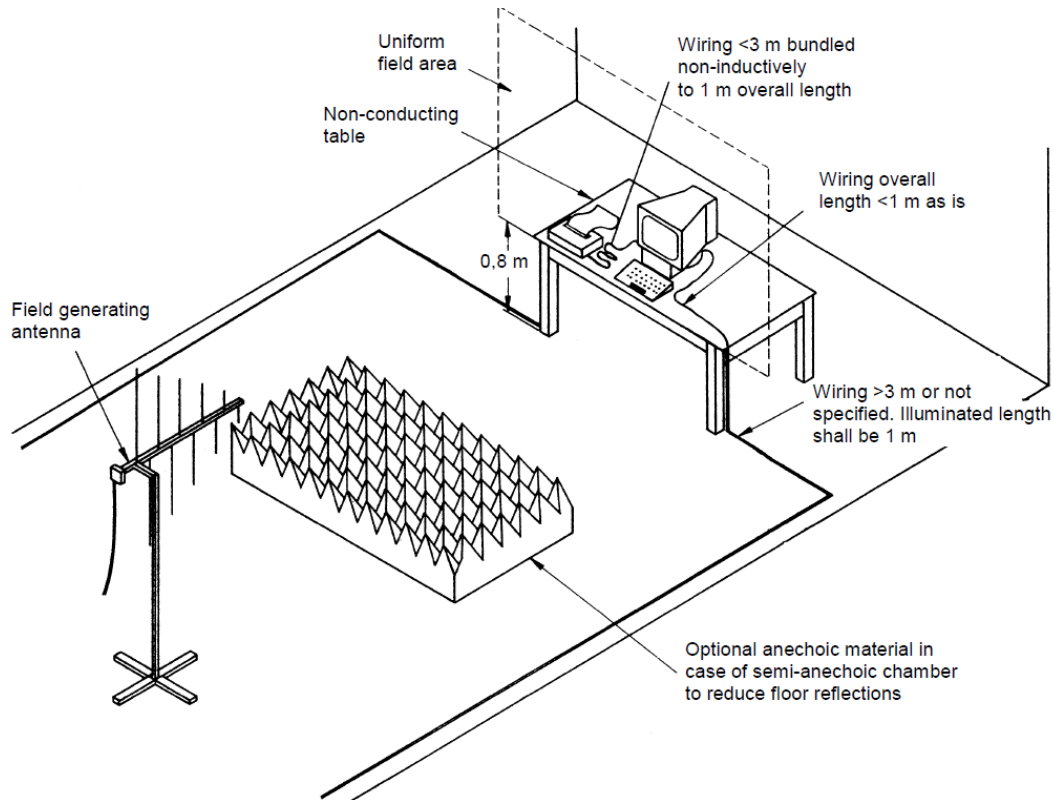

Note:

TABLE-TOP EQUIPMENT

The EUT installed in a representative system as described in EN 61000-4-3 was placed on a non-conductive table 0.8 meters in height. The system under test was connected to the power and signal wire according to relevant installation instructions.

FLOOR-STANDING EQUIPMENT

The EUT installed in a representative system as described in EN 61000-4-3 was placed on a non-conductive wood support 0.1 meters in height. The system under test was connected to the power and signal wire according to relevant installation instructions.

5.5.6 TEST RESULTS

EUT	LCD Monitor	Model Name	238LM00009
Temperature	26°C	Relative Humidity	45%
Test Voltage	AC 230V/50Hz		
Test Mode	HDMI 2560*1440 60Hz (715G8083)		

Frequency Range (MHz)	RF Field Position	R.F. Field Strength	Azimuth	Criterion	Result	Judgment
80 - 1000	H / V	3 V/m (unmodulated, r.m.s) AM Modulated 1 kHz, 80%	0°	A	A	PASS
			90°			
			180°			
			270°			

Note:

- 1) P/N denotes the Positive/Negative polarity of the output voltage.
- 2) N/A - denotes test is not applicable in this test report.
- 3) Criterion A: No observation of any performance degradation.
- 4) Criterion B: Some degradation of performance is observed but the equipment continues to operate as intended.
- 5) Criterion C: Loss of functionality, but self-recoverable by user, without loss of information or settings.

EUT	LCD Monitor	Model Name	238LM00009
Temperature	26°C	Relative Humidity	45%
Test Voltage	AC 230V/50Hz		
Test Mode	HDMI 2 2560*1440 144Hz (715G8055)		

Frequency Range (MHz)	RF Field Position	R.F. Field Strength	Azimuth	Criterion	Result	Judgment
80 - 1000	H / V	3 V/m (r.m.s.) AM Modulated 1 kHz, 80%	0°	A	A	PASS
			90°			
			180°			
			270°			

Note:

- 1) P/N denotes the Positive/Negative polarity of the output voltage.
- 2) N/A - denotes test is not applicable in this test report.
- 3) Criterion A: No observation of any performance degradation.
- 4) Criterion B: Some degradation of performance is observed but the equipment continues to operate as intended.
- 5) Criterion C: Loss of functionality, but self-recoverable by user, without loss of information or settings.

5.6 ELECTRICAL FAST TRANSIENT/BURST IMMUNITY TEST (EFT/BURST)

5.6.1 TEST SPECIFICATION

Basic Standard	EN 61000-4-4
Required Performance	B
Test Voltage	Power Line: ± 1 kV
Polarity	Positive & Negative
Impulse Frequency	5 kHz
Impulse Wave shape	5/50 ns
Burst Duration	15 ms
Burst Period	300 ms
Test Duration	Not less than 1 min.

5.6.2 MEASUREMENT INSTRUMENTS

Item	Kind of Equipment	Manufacturer	Type No.	Serial No.	Calibrated until
1	THE MODULAR SOLUTION FOR 6 KV APPLICATIONS	Teseq	NSG 3060	1423	Oct. 11, 2016
2	Measurement Software	Teseq	Win 3000 Version 1.2.0	N/A	N/A

Remark: "N/A" denotes no model name, no serial no. or no calibration specified.

All calibration period of equipment list is one year.

5.6.3 TEST PROCEDURE

The EUT and support equipment(s) are placed on a table that is 0.8 meter high above a metal ground plane and should be located 0.1 m \pm 0.01m high above the Ground Reference Plane (1m*1m min. and 0.65mm thick min).

The other condition as following manner:

- The length of power cord between the coupling device and the EUT should not exceed 1 meter.
- Both positive and negative polarity discharges were applied.
- The duration time of each test sequential was 1 minute

5.6.4 DEVIATION FROM TEST STANDARD

No deviation

5.6.5 TEST SETUP

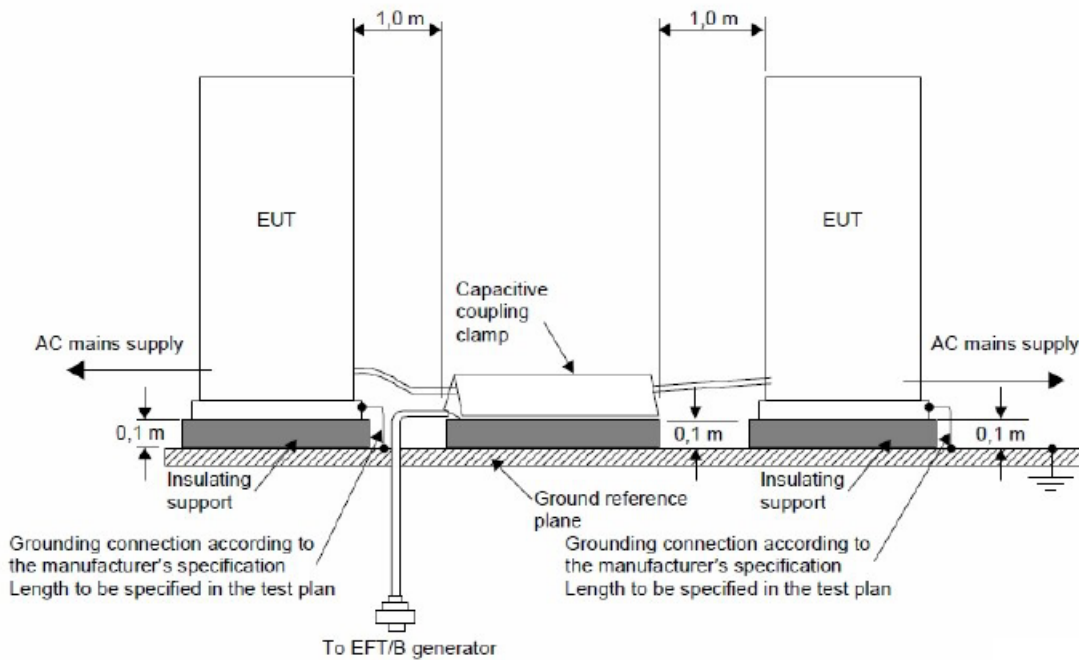
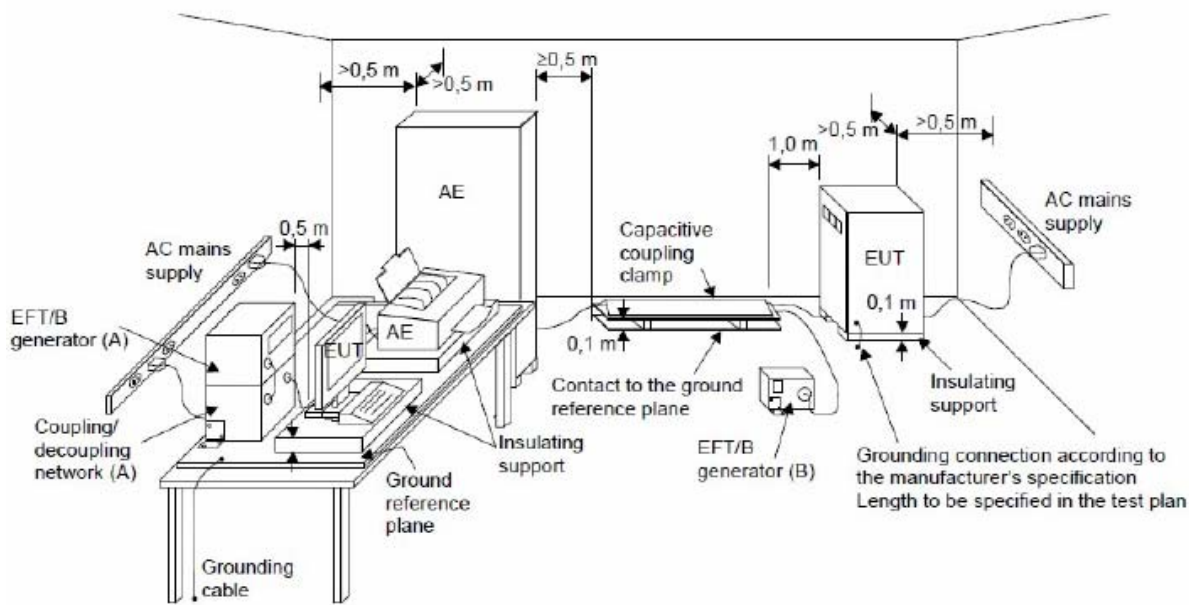

Note:

TABLE-TOP EQUIPMENT

The configuration consisted of a wooden table (0.8m high) standing on the Ground Reference Plane and should be located 0.1 m+/- 0.01m above the Ground Reference Plane. The GRP consisted of a sheet of aluminum (at least 0.25mm thick and 2.5m square) connected to the protective grounding system. A minimum distance of 0.5m was provided between the EUT and the walls of the laboratory or any other metallic structure.

FLOOR-STANDING EQUIPMENT

The EUT installed in a representative system as described in EN 61000-4-4 and its cables were isolated from the Ground Reference Plane by an insulating support that is 0.1-meter thick. The GRP consisted of a sheet of aluminum (at least 0.25mm thick and 2.5m square) connected to the protective grounding system.

5.6.6 TEST RESULTS

EUT	LCD Monitor	Model Name	238LM00009
Temperature	26°C	Relative Humidity	45%
Test Voltage	AC 230V/50Hz		
Test Mode	HDMI 2560*1440 60Hz (715G8083)		

EUT Ports Tested		Polarity	Repetition Frequency	Test Level	Criterion	Result	Judgment
				1 kV			
AC Power Port	Line (L)	+	5 kHz	A	B	A	PASS
		-	5 kHz	A			
	Neutral (N)	+	5 kHz	A	B	A	PASS
		-	5 kHz	A			
	Ground (PE)	+	5 kHz	A	B	A	PASS
		-	5 kHz	A			

Note:

- 1) N/A - denotes test is not applicable in this test report
- 2) Criterion A: No observation of any performance degradation.
- 3) Criterion B: Some degradation of performance is observed but the equipment continues to operate as intended.
- 4) Criterion C: Loss of functionality, but self-recoverable by user, without loss of information or settings.

EUT	LCD Monitor	Model Name	238LM00009
Temperature	26°C	Relative Humidity	45%
Test Voltage	AC 230V/50Hz		
Test Mode	HDMI 2 2560*1440 144Hz (715G8055)		

EUT Ports Tested		Polarity	Repetition Frequency	Test Level	Criterion	Result	Judgment
				1 kV			
AC Power Port	Line (L)	+	5 kHz	A	B	A	PASS
		-	5 kHz	A			
	Neutral (N)	+	5 kHz	A	B	A	PASS
		-	5 kHz	A			
	Ground (PE)	+	5 kHz	A	B	A	PASS
		-	5 kHz	A			

Note:

- 1) N/A - denotes test is not applicable in this test report
- 2) Criterion A: No observation of any performance degradation.
- 3) Criterion B: Some degradation of performance is observed but the equipment continues to operate as intended.
- 4) Criterion C: Loss of functionality, but self-recoverable by user, without loss of information or settings.

5.7 SURGE IMMUNITY TEST

5.7.1 TEST SPECIFICATION

Basic Standard	EN 61000-4-5
Required Performance	B (For Power Line)
Wave-Shape	Combination Wave for power lines 1.2/50 us Open Circuit Voltage 8 /20 us Short Circuit Current
Test Voltage	Power Line: ± 0.5 kV, ± 1 kV, ± 1.5 kV, ± 2 kV
Surge Input/Output	L-N, L-PE, N-PE
Generator Source Impedance	2 ohm between networks 12 ohm between network and ground
Polarity	Positive/Negative
Phase Angle	AC Port: $0^\circ/90^\circ/180^\circ/270^\circ$
Pulse Repetition Rate	1 time / min. (maximum)
Number of Tests	5 positive and 5 negative at selected points

5.7.2 MEASUREMENT INSTRUMENTS

Item	Kind of Equipment	Manufacturer	Type No.	Serial No.	Calibrated until
1	THE MODULAR SOLUTION FOR 6 KV APPLICATIONS	Teseq	NSG 3060	1423	Oct. 11, 2016
2	Measurement Software	Teseq	Win 3000 Version 1.2.0	N/A	N/A

Remark: "N/A" denotes no model name, no serial no. or no calibration specified.
All calibration period of equipment list is one year.

5.7.3 TEST PROCEDURE

a. For EUT power supply:

The surge is to be applied to the EUT power supply terminals via the capacitive coupling network. Decoupling networks are required in order to avoid possible adverse effects on equipment not under test that may be powered by the same lines, and to provide sufficient decoupling impedance to the surge wave. The power cord between the EUT and the coupling/decoupling networks shall be 2 meters in length (or shorter).

b. For test applied to unshielded unsymmetrically operated interconnection lines of EUT:

The surge is applied to the lines via the capacitive coupling. The coupling /decoupling networks shall not influence the specified functional conditions of the EUT. The interconnection line between the EUT and the coupling/decoupling networks shall be 2 meters in length (or shorter).

c. For test applied to unshielded symmetrically operated interconnection /telecommunication lines of EUT:

The surge is applied to the lines via gas arrestors coupling. Test levels below the ignition point of the coupling arrestor cannot be specified. The interconnection line between the EUT and the coupling/decoupling networks shall be 2 meters in length (or shorter).

5.7.4 DEVIATION FROM TEST STANDARD

No deviation

5.7.5 TEST SETUP

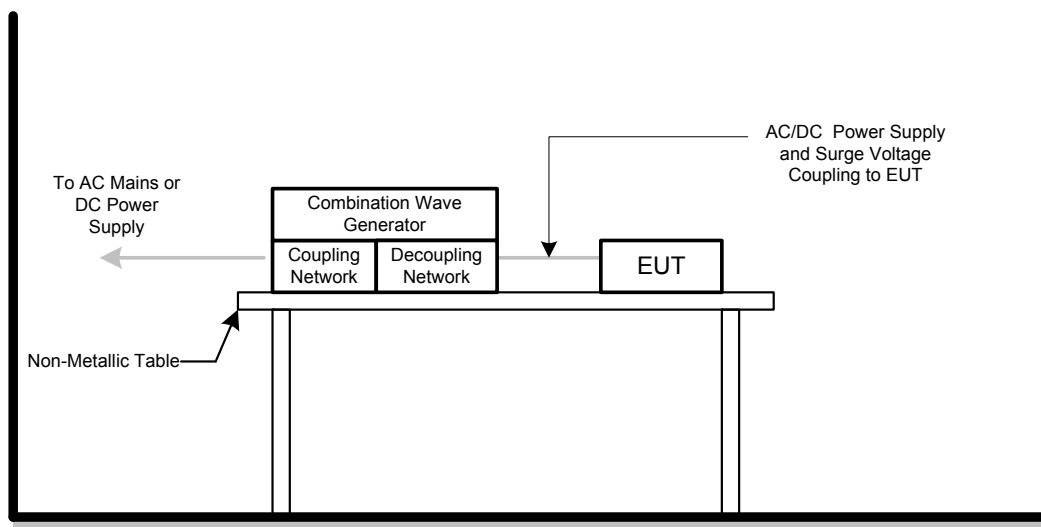

5.7.6 TEST RESULTS

EUT	LCD Monitor	Model Name	238LM00009
Temperature	26°C	Relative Humidity	45%
Test Voltage	AC 230V/50Hz		
Test Mode	HDMI 2560*1440 60Hz (715G8083)		

Wave Form EUT Ports Tested		1.2/50(8/20)Tr/Th μ s						Criterion	Result	Judgment
		Polarity	Phase	Voltage						
				0.5 kV	1 kV	1.5 kV	2 kV			
AC	L – N (2 ohm)	+/-	0°	A	A	-	-	B	A	PASS
		+/-	90°	A	A	-	-			
		+/-	180°	A	A	-	-			
		+/-	270°	A	A	-	-			
	L – PE (12 ohm)	+/-	0°	A	A	A	A	B	A	PASS
		+/-	90°	A	A	A	A			
		+/-	180°	A	A	A	A			
		+/-	270°	A	A	A	A			
	N – PE (12 ohm)	+/-	0°	A	A	A	A	B	A	PASS
		+/-	90°	A	A	A	A			
		+/-	180°	A	A	A	A			
		+/-	270°	A	A	A	A			

Wave Form EUT Ports Tested		1.2/50(8/20)Tr/Th μ s						Criterion	Result	Judgment
		Polarity	Voltage							
			0.5 kV	1 kV	- kV	- kV				
Signal Line	N/A (42 ohm)	+/-	-	-	-	-	C	N/A	N/A	

Note:

- 1) Polarity and Numbers of Impulses : 5 Pst / Ngt at each tested mode
- 2) N/A - denotes test is not applicable in this Test Report
- 3) Criterion A: No observation of any performance degradation.
- 4) Criterion B: Some degradation of performance is observed but the equipment continues to operate as intended.
- 5) Criterion C: Loss of functionality, but self-recoverable by user, without loss of information or settings.

EUT	LCD Monitor	Model Name	238LM00009
Temperature	26°C	Relative Humidity	45%
Test Voltage	AC 230V/50Hz		
Test Mode	HDMI 2 2560*1440 144Hz (715G8055)		

Wave Form EUT Ports Tested		1.2/50(8/20)Tr/Th μ s						Criterion	Result	Judgment
		Polarity	Phase	Voltage						
				0.5 kV	1 kV	1.5 kV	2 kV			
AC	L – N (2 ohm)	+/-	0°	A	A	-	-	B	A	PASS
		+/-	90°	A	A	-	-			
		+/-	180°	A	A	-	-			
		+/-	270°	A	A	-	-			
	L – PE (12 ohm)	+/-	0°	A	A	A	A	B	A	PASS
		+/-	90°	A	A	A	A			
		+/-	180°	A	A	A	A			
		+/-	270°	A	A	A	A			
	N – PE (12 ohm)	+/-	0°	A	A	A	A	B	A	PASS
		+/-	90°	A	A	A	A			
		+/-	180°	A	A	A	A			
		+/-	270°	A	A	A	A			

Wave Form EUT Ports Tested		1.2/50(8/20)Tr/Th μ s				Criterion	Result	Judgment	
		Polarity	Voltage						
			0.5 kV	1 kV	- kV				- kV
Signal Line	N/A (42 ohm)	+/-	-	-	-	-	C	N/A	N/A

Note:

- 1) Polarity and Numbers of Impulses : 5 Pst / Ngt at each tested mode
- 2) N/A - denotes test is not applicable in this Test Report
- 3) Criterion A: No observation of any performance degradation.
- 4) Criterion B: Some degradation of performance is observed but the equipment continues to operate as intended.
- 5) Criterion C: Loss of functionality, but self-recoverable by user, without loss of information or settings.

5.8 IMMUNITY TO CONDUCTED DISTURBANCES, INDUCED BY RADIO-FREQUENCY FIELDS TEST (CS)

5.8.1 TEST SPECIFICATION

Basic Standard	EN 61000-4-6
Required Performance	A
Frequency Range	0.15 MHz - 80 MHz
Field Strength	3 V (unmodulated, r.m.s)
Modulation	1 kHz Sine Wave, 80%, AM Modulation
Frequency Step	1% of fundamental
Dwell Time	at least 3 seconds

5.8.2 MEASUREMENT INSTRUMENTS

Item	Kind of Equipment	Manufacturer	Type No.	Serial No.	Calibrated until
1	Signal Generator	HP	8648A	3636A02964	Mar. 27, 2017
2	Power Amplifier	Teseq	CBA230M-080	T43748	Mar. 27, 2017
3	Power CDN	FCC	FCC-801-M2/M3 -16A	100271	Mar. 27, 2017
4	Measurement Software	TOYO	IM5/C Ver 3.7.028	N/A	N/A

Remark: "N/A" denotes no model name, no serial no. or no calibration specified.

All calibration period of equipment list is one year.

5.8.3 TEST PROCEDURE

The EUT and support equipment, are placed on a table that is 0.8 meter above a metal ground plane measured 1m*1m min. and 0.65mm thick min.

The other condition as following manner:

- a. The field strength level was 3 V (unmodulated, r.m.s).
- b. The frequency range is swept from 150 kHz to 80 MHz, with the signal 80% amplitude modulated with a 1 kHz sine wave. The rate of sweep did not exceed 1.5×10^{-3} decade/s. Where the frequency range is swept incrementally, the step size was 1% of fundamental.
- c. The dwell time at each frequency shall be not less than the time necessary for the EUT to be able to respond.

5.8.4 DEVIATION FROM TEST STANDARD

No deviation

5.8.5 TEST SETUP

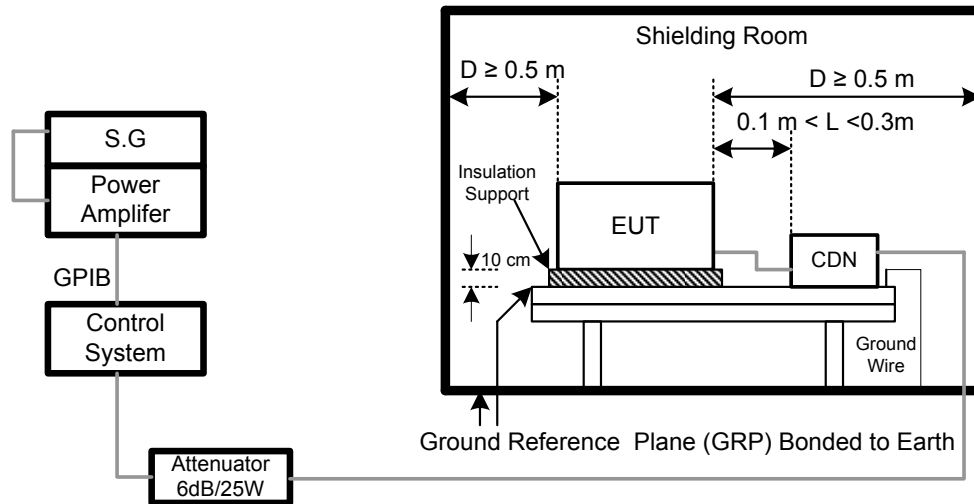

NOTE:

FLOOR-STANDING EQUIPMENT

The equipment to be tested is placed on an insulating support of 0.1 meters height above a ground reference plane. All relevant cables shall be provided with the appropriate coupling and decoupling devices at a distance between 0.1 meters and 0.3 meters from the projected geometry of the EUT on the ground reference plane.

5.8.6 TEST RESULTS

EUT	LCD Monitor	Model Name	238LM00009
Temperature	26°C	Relative Humidity	45%
Test Voltage	AC 230V/50Hz		
Test Mode	HDMI 2560*1440 60Hz (715G8083)		

Test Ports (Mode)	Freq. Range (MHz)	Field Strength	Criterion	Result	Judgment
Input/ Output AC. Power Port	0.15 - 80	3 V (unmodulated, r.m.s) AM Modulated 1 kHz, 80%	A	A	PASS
Input/ Output DC. Power Port			A	N/A	N/A
Signal Line			A	N/A	N/A

Note:

- 1) N/A - denotes test is not applicable in this Test Report.
- 2) Criterion A: No observation of any performance degradation.
- 3) Criterion B: Some degradation of performance is observed but the equipment continues to operate as intended.
- 4) Criterion C: Loss of functionality, but self-recoverable by user, without loss of information or settings.

EUT	LCD Monitor	Model Name	238LM00009
Temperature	26°C	Relative Humidity	45%
Test Voltage	AC 230V/50Hz		
Test Mode	HDMI 2 2560*1440 144Hz (715G8055)		

Test Ports (Mode)	Freq. Range (MHz)	Field Strength	Criterion	Result	Judgment
Input/ Output AC. Power Port	0.15 - 80	3 Vr.m.s. AM Modulated 1 kHz, 80%	A	A	PASS
Input/ Output DC. Power Port			A	N/A	N/A
Signal Line			A	N/A	N/A

Note:

- 1) N/A - denotes test is not applicable in this Test Report.
- 2) Criterion A: No observation of any performance degradation.
- 3) Criterion B: Some degradation of performance is observed but the equipment continues to operate as intended.
- 4) Criterion C: Loss of functionality, but self-recoverable by user, without loss of information or settings.

5.9 POWER FREQUENCY MAGNETIC FIELD IMMUNITY TEST (PFMF)

5.9.1 TEST SPECIFICATION

Basic Standard	EN 61000-4-8
Required Performance	A
Frequency Range	50/60 Hz
Field Strength	1 A/m
Observation Time	1 minute
Inductance Coil	Rectangular type, 1mx1m

5.9.2 MEASUREMENT INSTRUMENTS

Item	Kind of Equipment	Manufacturer	Type No.	Serial No.	Calibrated until
1	Magnetic Field Test Generator	FCC	F-1000-4-8-G-125A	04032	Mar. 27, 2017
2	Magnetic Field immunity loop	Thermo KeyTek	F-1000-4-8/9/10-L-1M	04024	Mar. 27, 2017

Remark: "N/A" denotes no model name, no serial no. or no calibration specified.

All calibration period of equipment list is one year.

5.9.3 TEST PROCEDURE

The EUT and support equipment, are placed on a table that is 0.8 meter above a metal ground plane measured 1m*1m min. and 0.65mm thick min.

The other condition as following manner:

- a. The equipment cabinets shall be connected to the safety earth directly on the GRP via the earth terminal of the EUT.
- b. The cables supplied or recommended by the equipment manufacturer shall be used. 1 meter of all cables used shall be exposed to the magnetic field.

5.9.4 DEVIATION FROM TEST STANDARD

No deviation

5.9.5 TEST SETUP

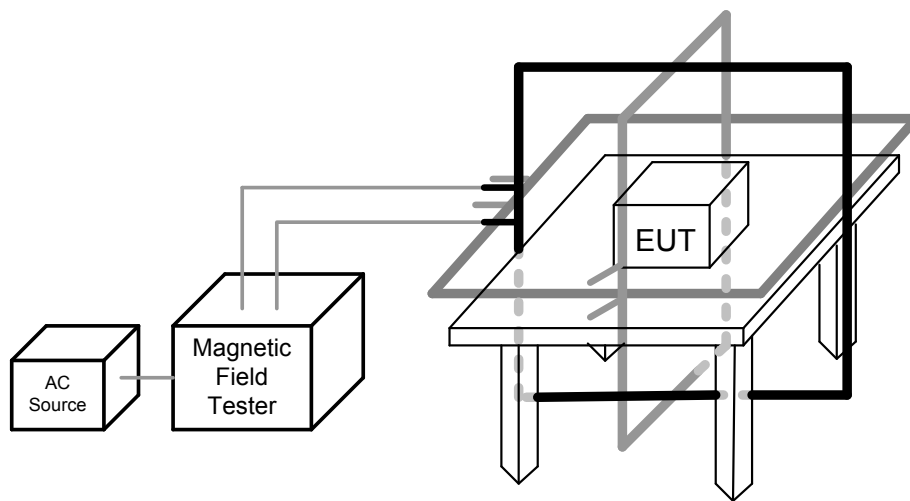

Note:

TABLE-TOP EQUIPMENT

The equipment shall be subjected to the test magnetic field by using the induction coil of standard dimension (1 m x 1 m). The induction coil shall then be rotated by 90 degrees in order to expose the EUT to the test field with different orientations.

FLOOR-STANDING EQUIPMENT

The equipment shall be subjected to the test magnetic field by using induction coils of suitable dimensions. The test shall be repeated by moving and shifting the induction coils, in order to test the whole volume of the EUT for each orthogonal direction. The test shall be repeated with the coil shifted to different positions along the side of the EUT, in steps corresponding to 50 percent of the shortest side of the coil. The induction coil shall then be rotated by 90 degrees in order to expose the EUT to the test field with different orientations.

5.9.6 TEST RESULTS

EUT	LCD Monitor	Model Name	238LM00009
Temperature	26°C	Relative Humidity	45%
Test Voltage	AC 230V/50Hz		
Test Mode	HDMI 2560*1440 60Hz (715G8083)		

Test Mode	Test Level	Antenna aspect	Duration (s)	Criterion	Result	Judgment
Enclosure	1 A/m 50/60 Hz	X	60	A	A	PASS
Enclosure	1 A/m 50/60 Hz	Y	60	A	A	PASS
Enclosure	1 A/m 50/60 Hz	Z	60	A	A	PASS

Note:

- 1) N/A - denotes test is not applicable in this test report
- 2) Criterion A: No observation of any performance degradation.
- 3) Criterion B: Some degradation of performance is observed but the equipment continues to operate as intended.
- 4) Criterion C: Loss of functionality, but self-recoverable by user, without loss of information or settings.

EUT	LCD Monitor	Model Name	238LM00009
Temperature	26°C	Relative Humidity	45%
Test Voltage	AC 230V/50Hz		
Test Mode	HDMI 2 2560*1440 144Hz (715G8055)		

Test Mode	Test Level	Antenna aspect	Duration (s)	Criterion	Result	Judgment
Enclosure	1 A/m 50/60 Hz	X	60	A	A	PASS
Enclosure	1 A/m 50/60 Hz	Y	60	A	A	PASS
Enclosure	1 A/m 50/60 Hz	Z	60	A	A	PASS

Note:

- 1) N/A - denotes test is not applicable in this test report
- 2) Criterion A: No observation of any performance degradation.
- 3) Criterion B: Some degradation of performance is observed but the equipment continues to operate as intended.
- 4) Criterion C: Loss of functionality, but self-recoverable by user, without loss of information or settings.

5.10 VOLTAGE DIPS, SHORT INTERRUPTIONS AND VOLTAGE VARIATIONS IMMUNITY TEST

5.10.1 TEST SPECIFICATION

Basic Standard	EN 61000-4-11
Required Performance	B (For >95% Voltage Dips) C (For 30% Voltage Dips) C (For >95% Voltage Interruptions)
Test Duration Time	Minimum three test events in sequence
Interval between Event	Minimum ten seconds
Phase Angle	0°/180°
Test Cycle	3 times

5.10.2 MEASUREMENT INSTRUMENTS

Item	Kind of Equipment	Manufacturer	Type No.	Serial No.	Calibrated until
1	THE MODULAR SOLUTION FOR 6 KV APPLICATIONS	Teseq	NSG 3060	1423	Oct. 11, 2016
2	Measurement Software	Teseq	Win 3000 Version 1.2.0	N/A	N/A

Remark: "N/A" denotes no model name, no serial no. or no calibration specified.

All calibration period of equipment list is one year.

5.10.3 TEST PROCEDURE

The EUT shall be tested for each selected combination of test levels and duration with a sequence of three dips/interruptions with intervals of 10 s minimum (between each test event). Each representative mode of operation shall be tested. Abrupt changes in supply voltage shall occur at zero crossings of the voltage waveform.

5.10.4 DEVIATION FROM TEST STANDARD

No deviation

5.10.5 TEST SETUP

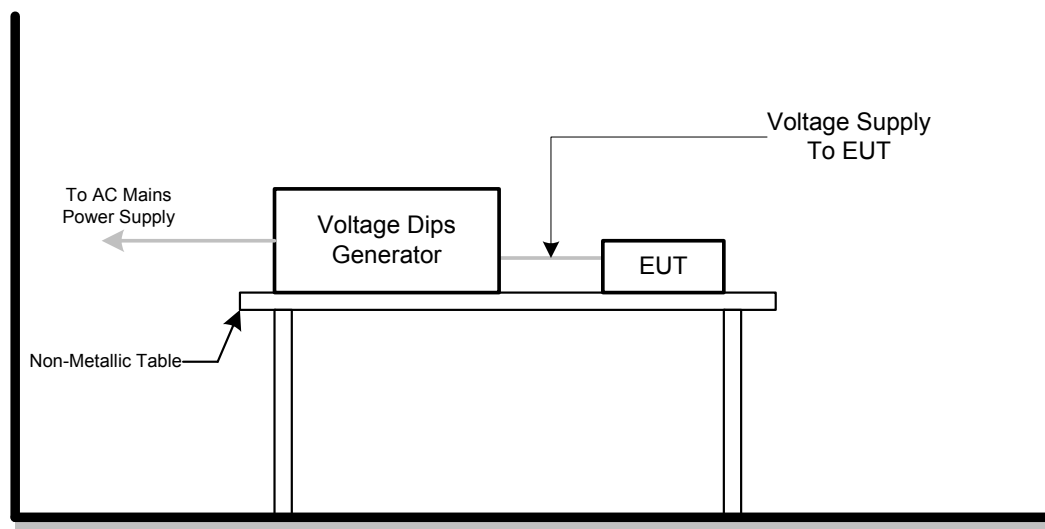

5.10.6 TEST RESULTS

EUT	LCD Monitor	Model Name	238LM00009
Temperature	26°C	Relative Humidity	45%
Test Voltage	AC 230V/50Hz		
Test Mode	HDMI 2560*1440 60Hz (715G8083)		

AC 100V/50Hz				
Voltage Reduction	Duration (Periods)	Criterion	Result	Judgment
Voltage Dips >95%	0.5	B	A	PASS
Voltage Dips 30%	25	C	C	PASS
Voltage Interruptions >95%	250	C	C	PASS

AC 230V/50Hz				
Voltage Reduction	Duration (Periods)	Criterion	Result	Judgment
Voltage Dips >95%	0.5	B	A	PASS
Voltage Dips 30%	25	C	A	PASS
Voltage Interruptions >95%	250	C	C	PASS

AC 240V/50Hz				
Voltage Reduction	Duration (Periods)	Criterion	Result	Judgment
Voltage Dips >95%	0.5	B	A	PASS
Voltage Dips 30%	25	C	A	PASS
Voltage Interruptions >95%	250	C	C	PASS

Note:

- 1). N/A - denotes test is not applicable in this test report.
- 2) Criterion A: No observation of any performance degradation.
- 3) Criterion B: Some degradation of performance is observed but the equipment continues to operate as intended.
- 4) Criterion C: Loss of functionality, but self-recoverable by user, without loss of information or settings.

EUT	LCD Monitor	Model Name	238LM00009
Temperature	26°C	Relative Humidity	45%
Test Voltage	AC 230V/50Hz		
Test Mode	HDMI 2 2560*1440 144Hz (715G8055)		

AC 100V/50Hz				
Voltage Reduction	Duration (Periods)	Criterion	Result	Judgment
Voltage Dips >95%	0.5	B	A	PASS
Voltage Dips 30%	25	C	C	PASS
Voltage Interruptions >95%	250	C	C	PASS

AC 230V/50Hz				
Voltage Reduction	Duration (Periods)	Criterion	Result	Judgment
Voltage Dips >95%	0.5	B	A	PASS
Voltage Dips 30%	25	C	A	PASS
Voltage Interruptions >95%	250	C	C	PASS

AC 240V/50Hz				
Voltage Reduction	Duration (Periods)	Criterion	Result	Judgment
Voltage Dips >95%	0.5	B	A	PASS
Voltage Dips 30%	25	C	A	PASS
Voltage Interruptions >95%	250	C	C	PASS

Note:

- 1). N/A - denotes test is not applicable in this test report.
- 2) Criterion A: No observation of any performance degradation.
- 3) Criterion B: Some degradation of performance is observed but the equipment continues to operate as intended.
- 4) Criterion C: Loss of functionality, but self-recoverable by user, without loss of information or settings.

6. EUT TEST PHOTO

Conducted Measurement Photos

PC Mode (715G8083)

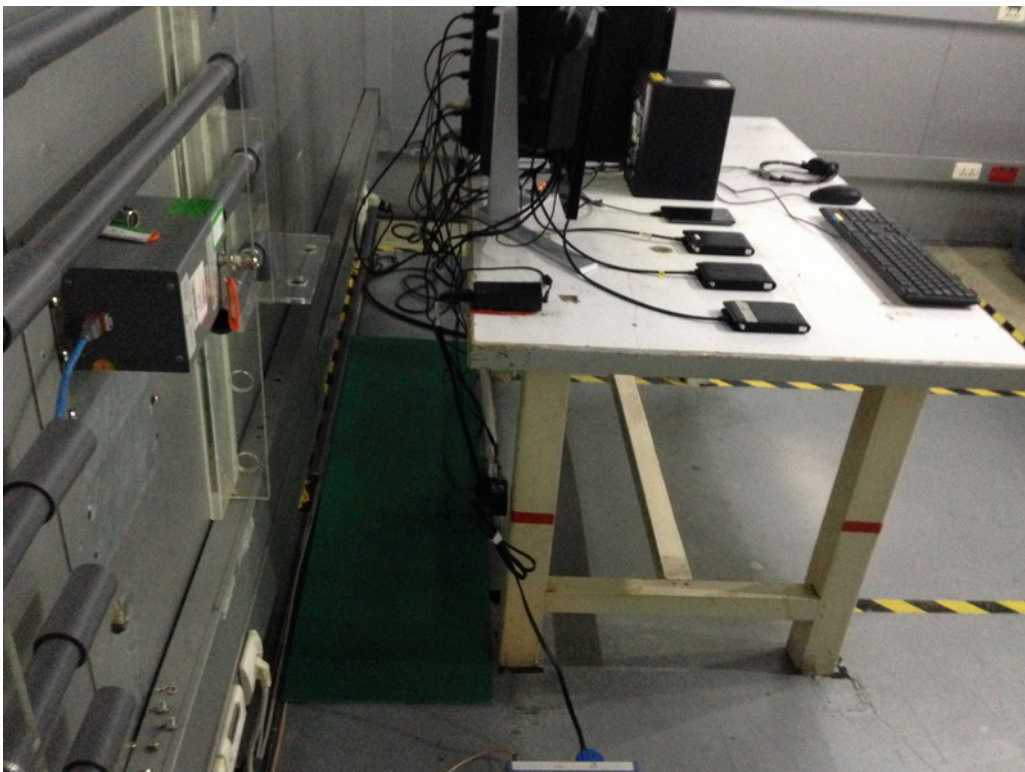

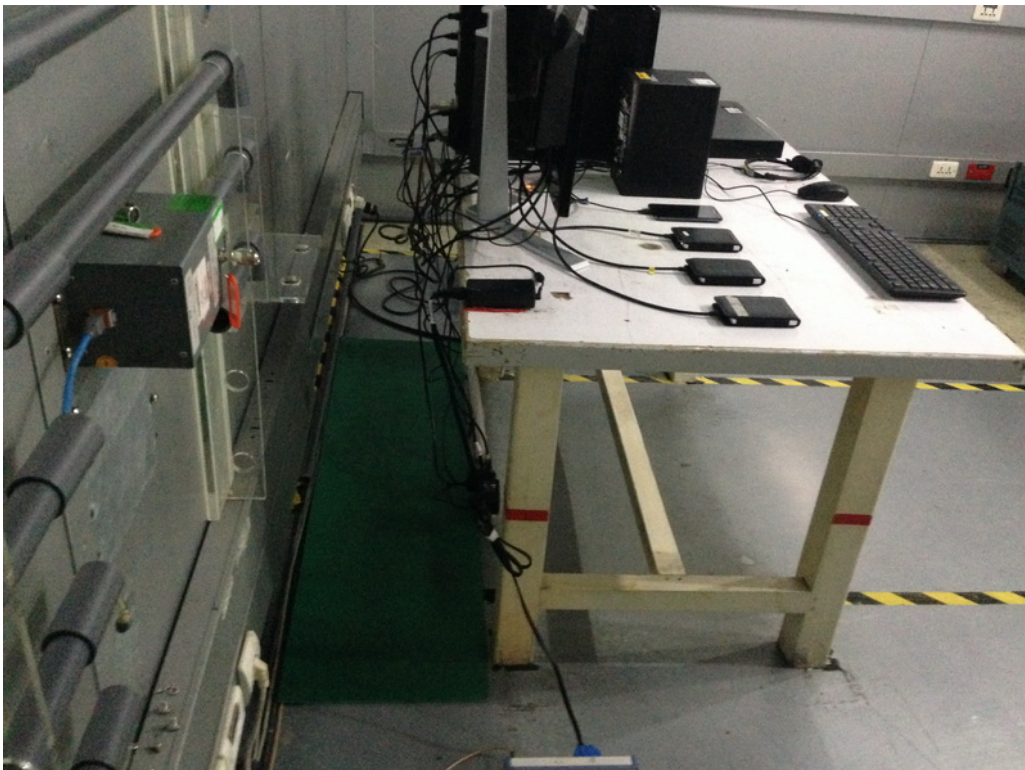
Conducted Measurement Photos**DVD Mode (715G8083)**

Radiated Measurement Photos

30MHz to 1GHz
PC Mode (715G8083)

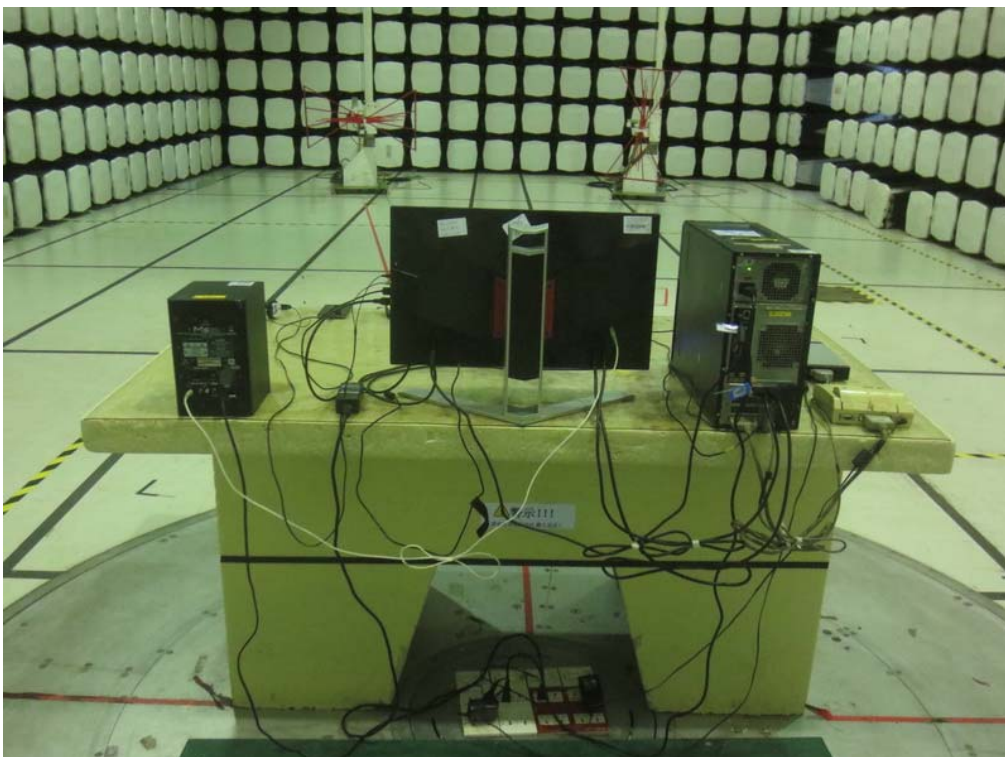

Radiated Measurement Photos

30MHz to 1GHz
DVD Mode (715G8083)

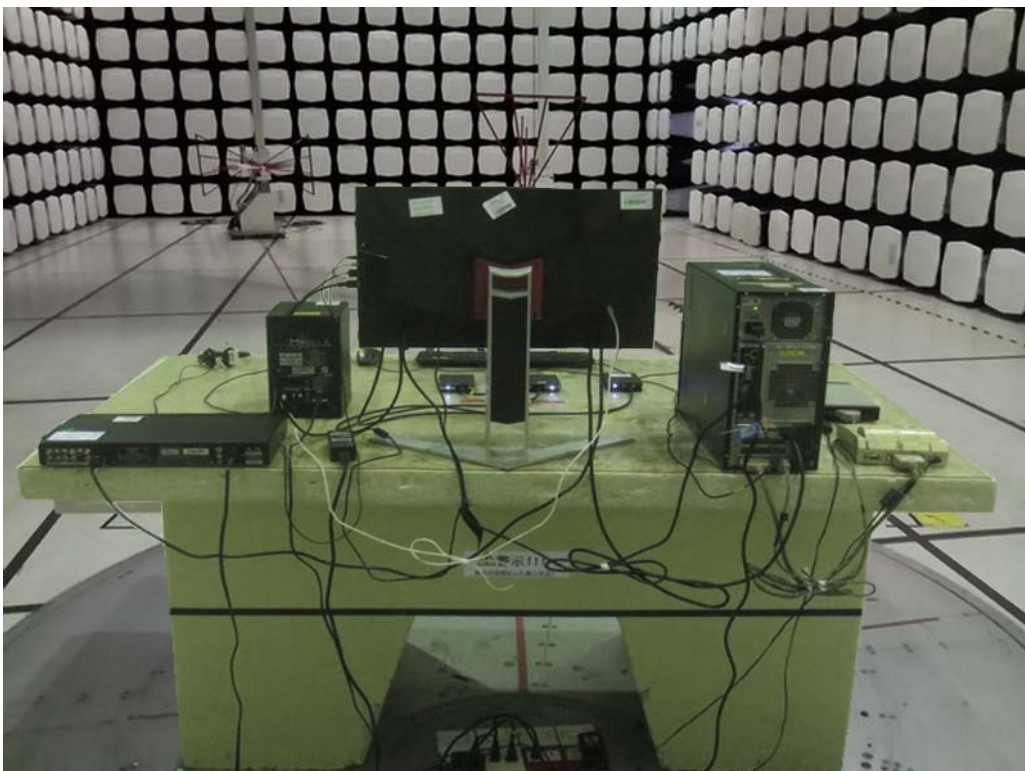
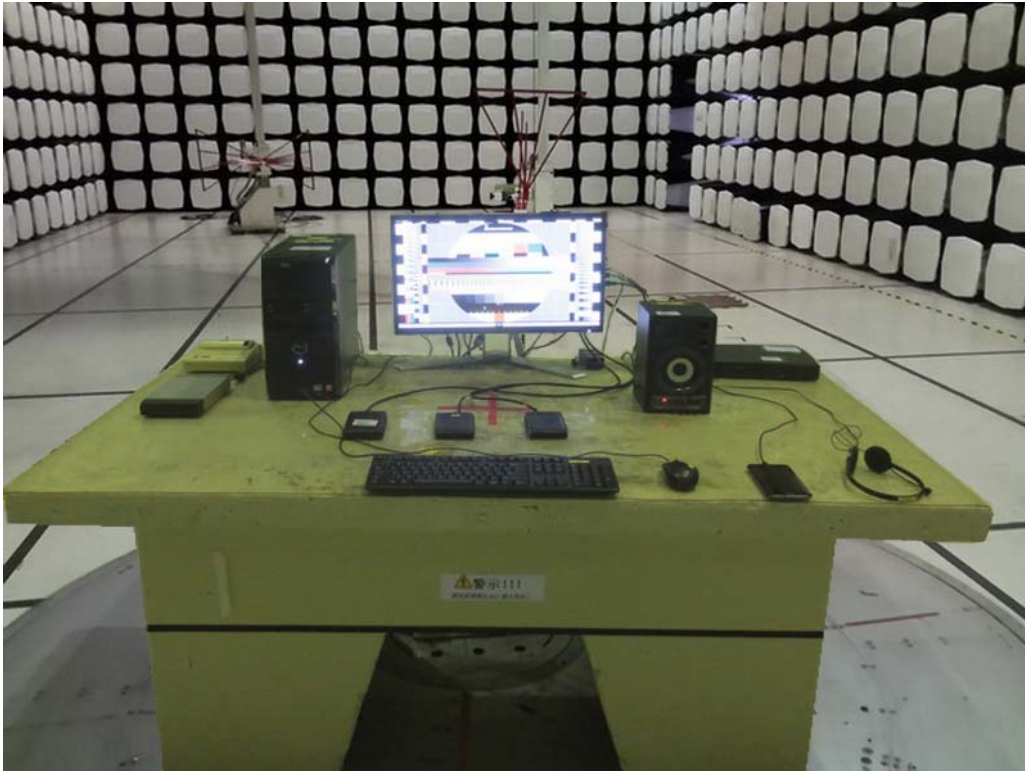

Radiated Measurement Photos

Above 1GHz
PC Mode (715G8083)

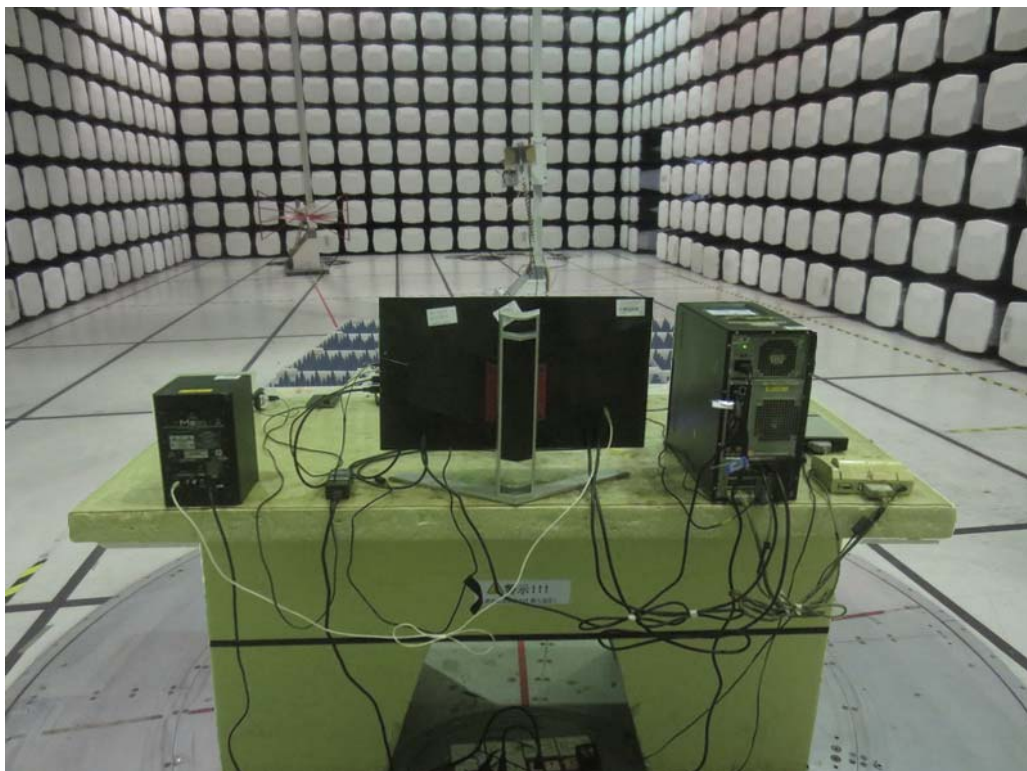
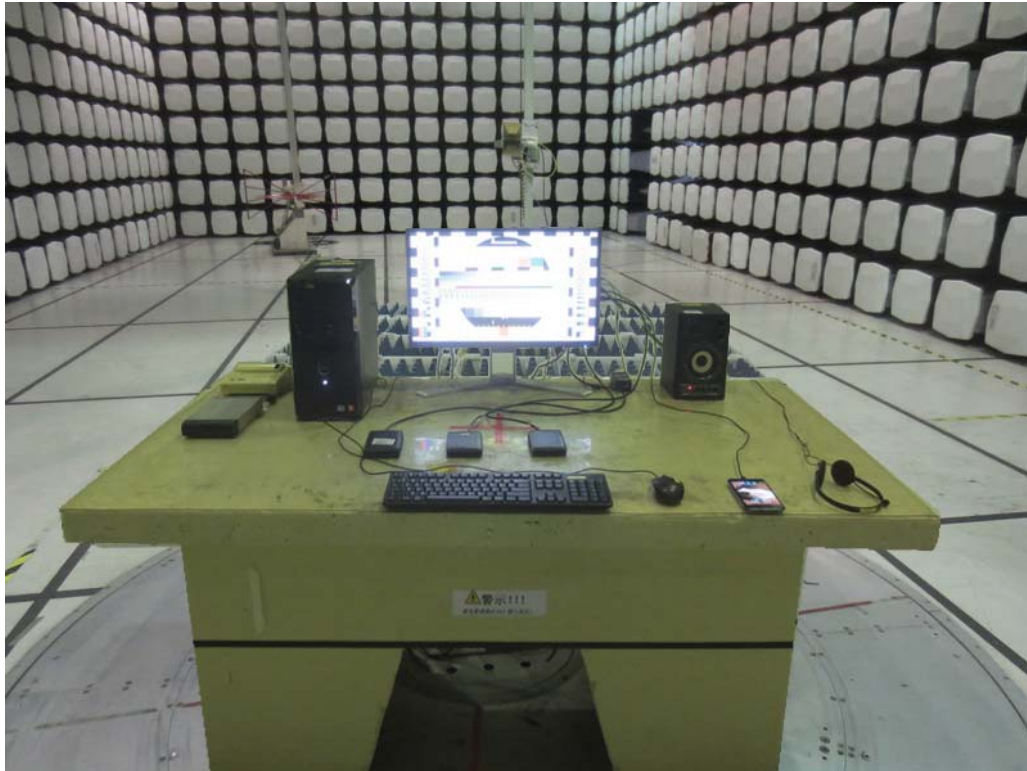

Radiated Measurement Photos

Above 1GHz
DVD Mode (715G8083)

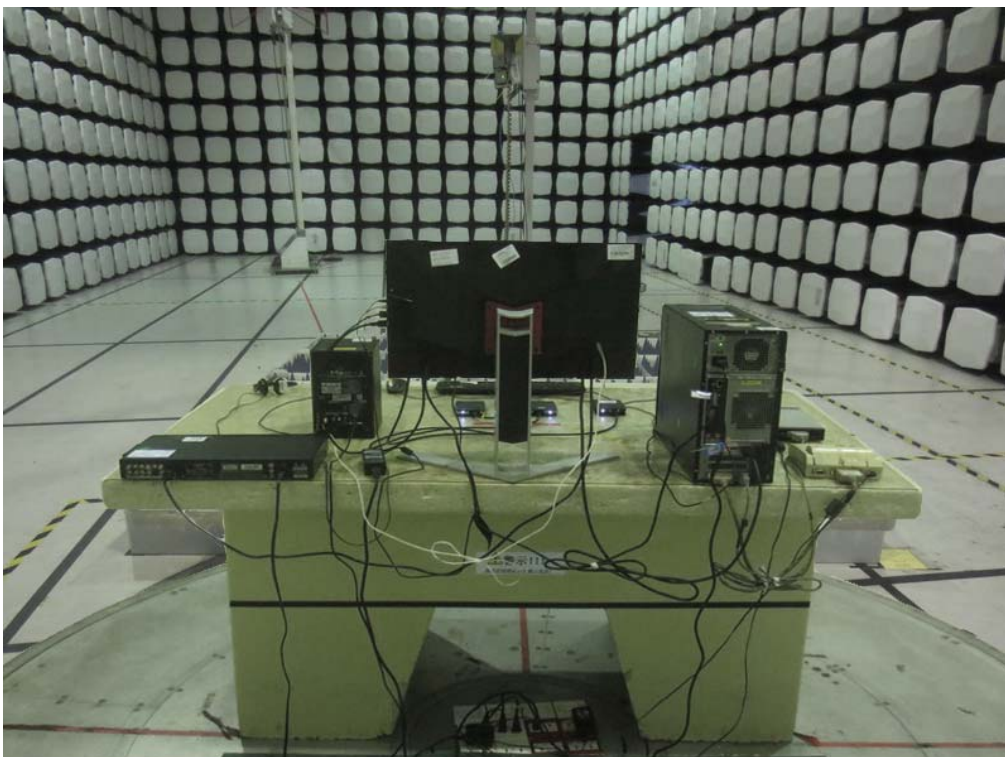

Harmonic & Flicker Measurement Photos (715G8083)

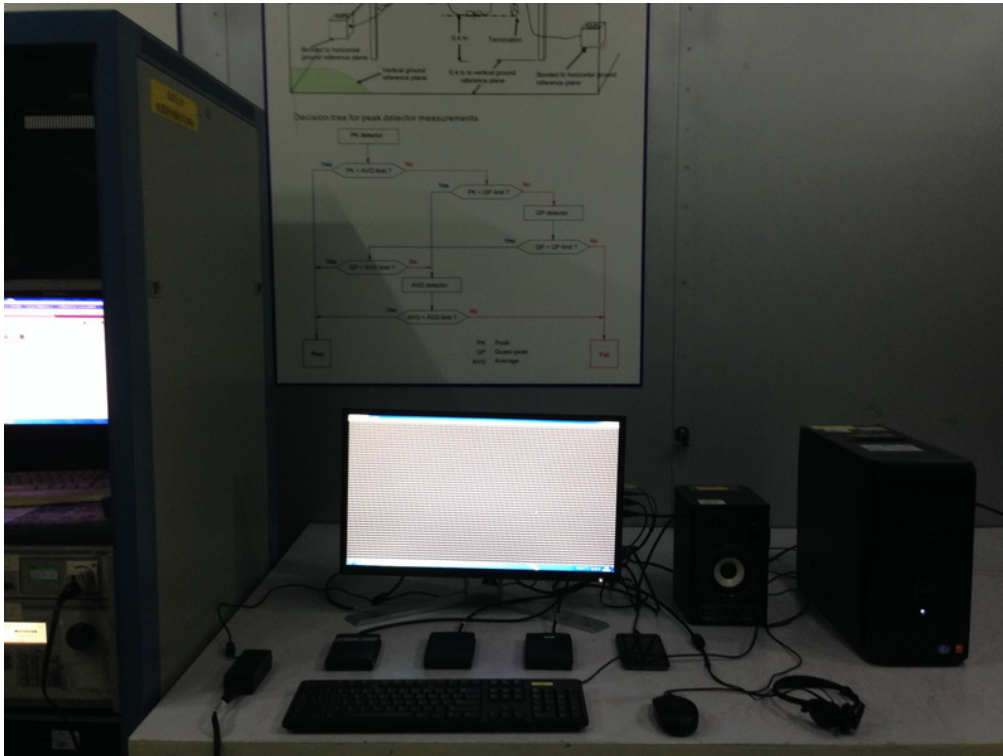

EMS Measurement Photos ESD (715G8083)

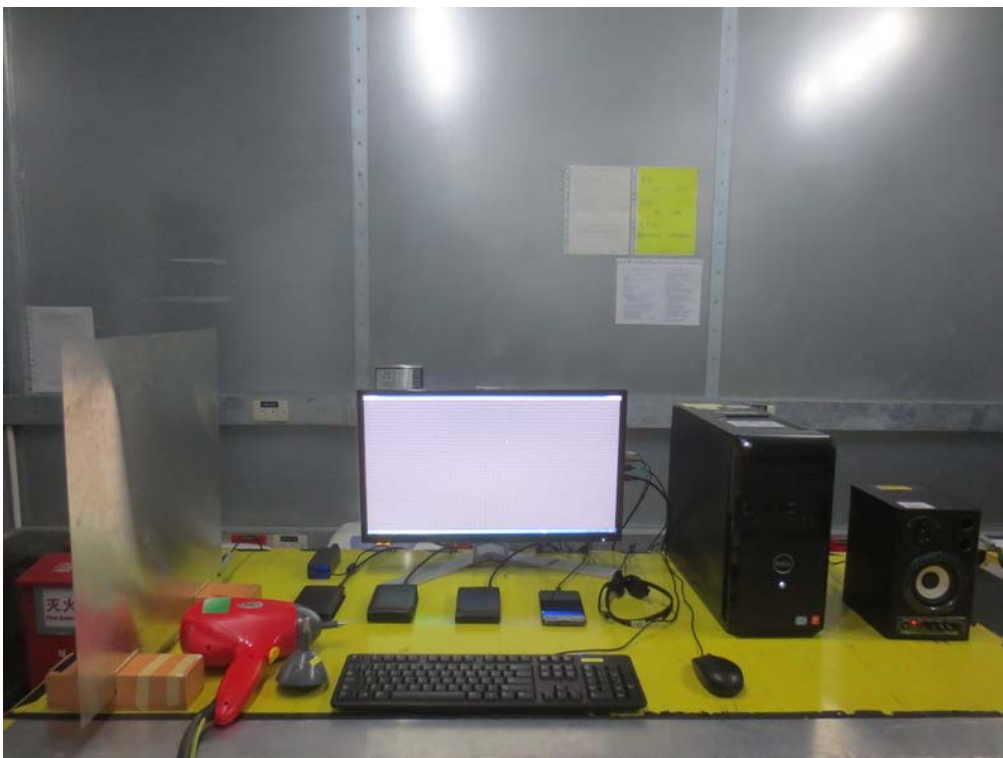

RS (715G8083)**EFT, Surge, DIP (715G8083)**

CS (715G8083)**PMF (715G8083)**

Conducted Measurement Photos**PC & DVD Mode (715G8055)**

Radiated Measurement Photos

30MHz to 1GHz
PC & DVD Mode (715G8055)

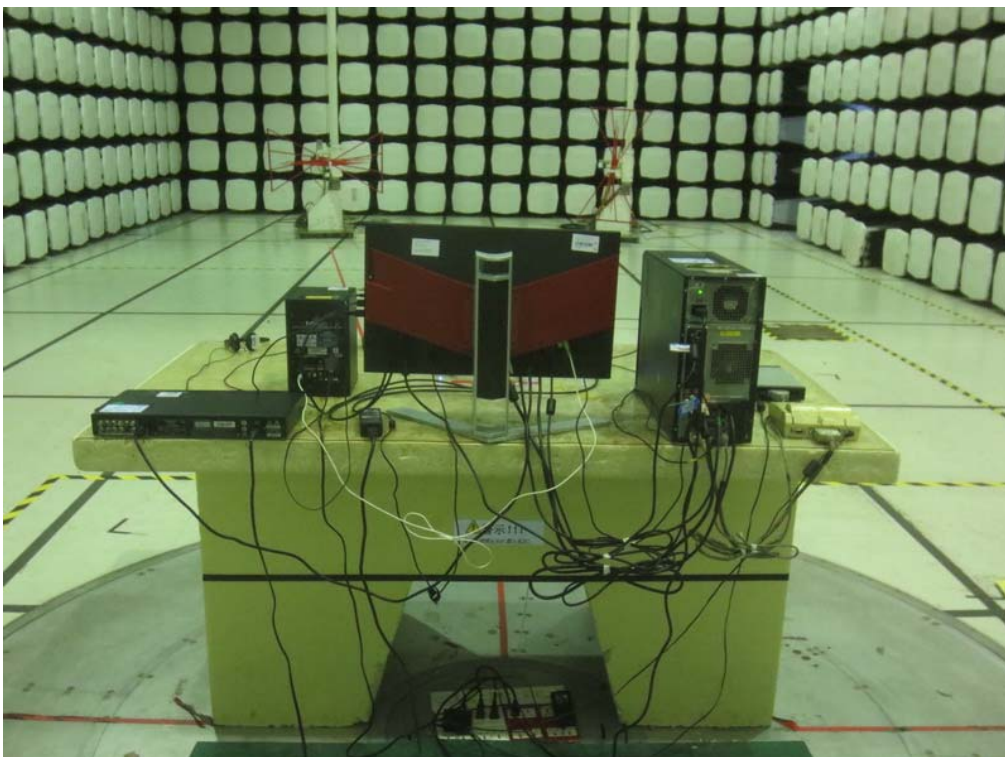
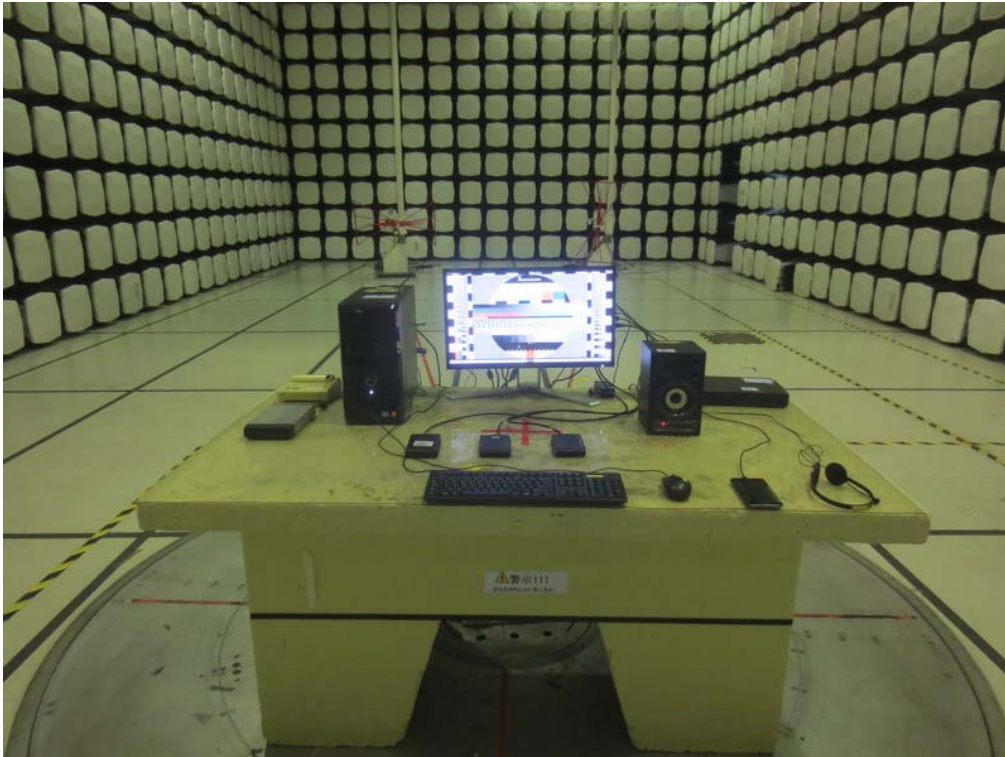

Radiated Measurement Photos

Above 1GHz
PC & DVD Mode (715G8055)

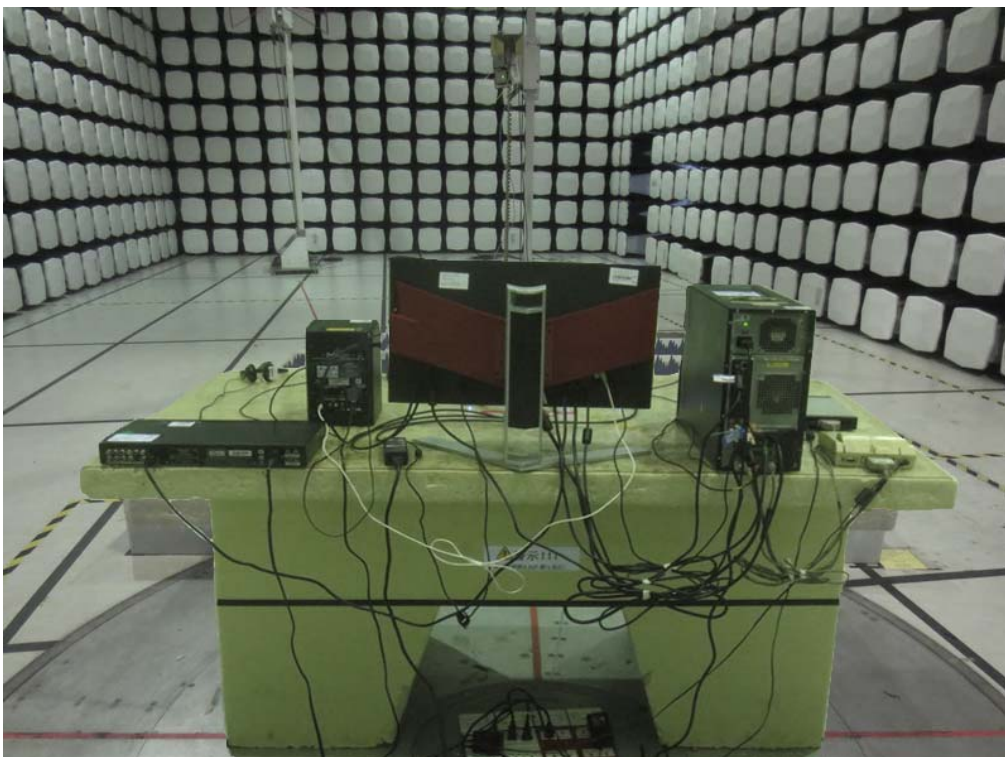

Harmonic & Flicker Measurement Photos (715G8055)

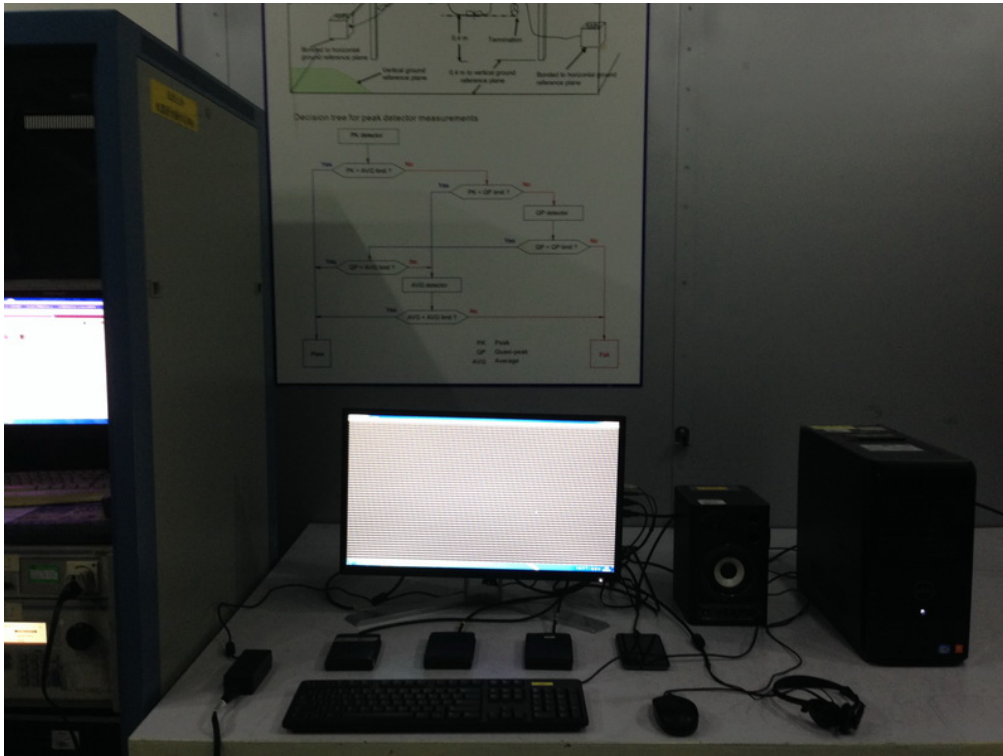

EMS Measurement Photos ESD (715G8055)

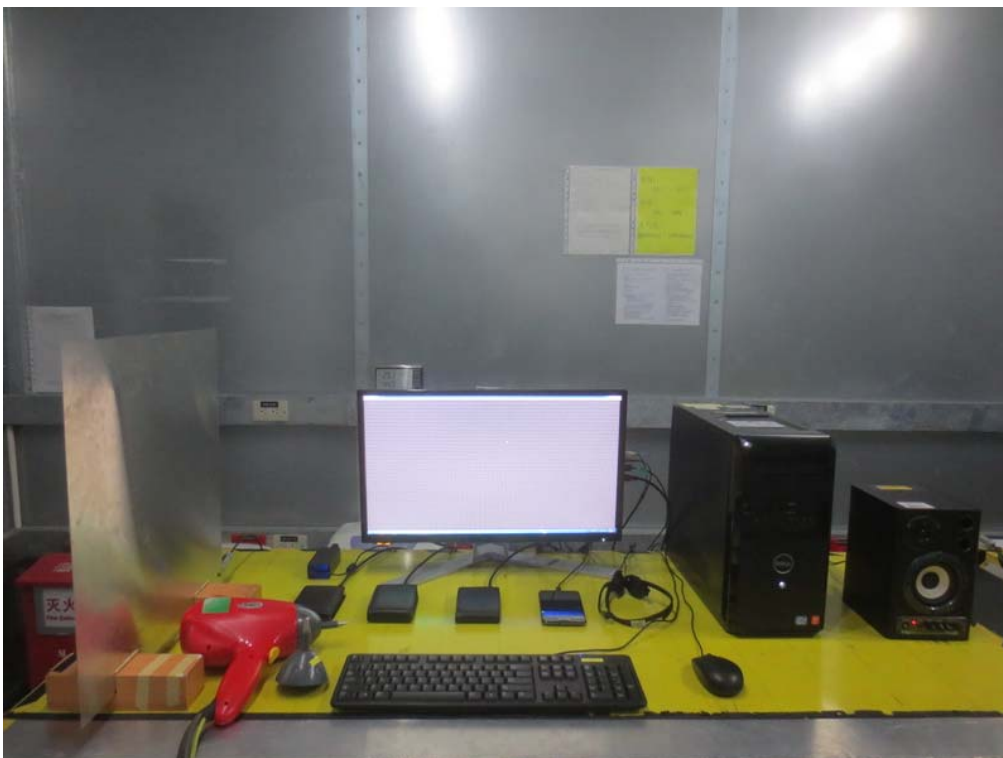

RS (715G8055)**EFT, Surge, DIP (715G8055)**

CS (715G8055)**PMF (715G8055)**