

# CE EMC Test Report

**Project No.** : 1905C010A  
**Equipment** : LCD Monitor  
**Brand Name** : N/A  
**Test Model** : \*\*27G2\*\*\*\*\*(\*=A-Z,a-z,0-9,/, +,-,\ or blank)  
**Series Model** : N/A  
**Applicant** : TPV Electronics (Fujian) Co., Ltd.  
**Address** : Rongqiao Economic and Technological Development Zone, Fuqing City,  
Fujian Province, P.R. China  
**Date of Receipt** : Aug. 22, 2019  
**Date of Test** : Aug. 22, 2019 ~ Mar. 23, 2020  
**Issued Date** : Apr. 03, 2020  
**Report Version** : R00  
**Test Sample** : Engineering Sample No.: DG201909035  
**Standard(s)** : EN 55032:2012+AC:2013  
EN 55032:2015  
EN 55032:2015+AC:2016  
IEC 61000-3-2:2014 / EN 61000-3-2:2014  
IEC 61000-3-3:2013+A1:2017 / EN 61000-3-3:2013+A1:2019  
EN 55024:2010  
EN 55024:2010+A1:2015  
AS/NZS CISPR 32:2015 / CISPR 32:2015+C1:2016  
AS/NZS CISPR 32:2013 / CISPR 32:2012

The above equipment has been tested and found compliance with the requirement of the relative standards by BTL Inc.

*Karpin Zhong*

Prepared by : Karpin Zhong

*Kevin Li*

Approved by : Kevin Li



Certificate #5123.02

Add: No.3, Jinshagang 1st Road, Shixia, Dalang Town, Dongguan, Guangdong, China.

Tel: +86-769-8318-3000

Web: www.newbtl.com

**Declaration**

**BTL** represents to the client that testing is done in accordance with standard procedures as applicable and that test instruments used has been calibrated with standards traceable to international standard(s) and/or national standard(s).

**BTL's** reports apply only to the specific samples tested under conditions. It is manufacture's responsibility to ensure that additional production units of this model are manufactured with the identical electrical and mechanical components. **BTL** shall have no liability for any declarations, inferences or generalizations drawn by the client or others from **BTL** issued reports.

The report must not be used by the client to claim product certification, approval, or endorsement by NVLAP, NIST, A2LA, or any agency of the U.S. Government.

This report is the confidential property of the client. As a mutual protection to the clients, the public and ourselves, the test report shall not be reproduced, except in full, without our written approval.

**BTL's** laboratory quality assurance procedures are in compliance with the **ISO/IEC 17025** requirements, and accredited by the conformity assessment authorities listed in this test report.

**BTL** is not responsible for the sampling stage, so the results only apply to the sample as received.

The information, data and test plan are provided by manufacturer which may affect the validity of results, so it is manufacturer's responsibility to ensure that the apparatus meets the essential requirements of applied standards and in all the possible configurations as representative of its intended use.

**Limitation**

For the use of the authority's logo is limited unless the Test Standard(s)/Scope(s)/Item(s) mentioned in this test report is (are) included in the conformity assessment authorities acceptance respective.

Please note that the measurement uncertainty is provided for informational purpose only and are not use in determining the Pass/Fail results.

<b>Table of Contents</b>	<b>Page</b>
<b>REPORT ISSUED HISTORY</b>	<b>7</b>
<b>1 . SUMMARY OF TEST RESULTS</b>	<b>8</b>
1.1 TEST FACILITY	9
1.2 MEASUREMENT UNCERTAINTY	9
1.3 TEST ENVIRONMENT CONDITIONS	11
<b>2 . GENERAL INFORMATION</b>	<b>12</b>
2.1 GENERAL DESCRIPTION OF EUT	12
2.2 DESCRIPTION OF TEST MODES	13
2.3 EUT OPERATING CONDITIONS	14
2.4 BLOCK DIAGRAM SHOWING THE CONFIGURATION OF SYSTEM TESTED	15
2.5 DESCRIPTION OF SUPPORT UNITS	16
<b>3 . EMC EMISSION TEST- EN55032:2012+AC:2013 &amp; 2015</b>	<b>17</b>
3.1 RADIATED EMISSION	17
3.1.1 LIMITS	17
3.1.2 MEASUREMENT INSTRUMENTS LIST	17
3.1.3 TEST PROCEDURE	18
3.1.4 DEVIATION FROM TEST STANDARD	18
3.1.5 TEST SETUP	18
3.1.6 MEASUREMENT DISTANCE	19
3.1.7 TEST RESULTS (UP TO 1 GHZ)	20
3.2 RADIATED EMISSION ABOVE 1 GHZ	28
3.2.1 LIMITS	28
3.2.2 MEASUREMENT INSTRUMENTS LIST	28
3.2.3 TEST PROCEDURE	29
3.2.4 DEVIATION FROM TEST STANDARD	29
3.2.5 TEST SETUP	29
3.2.6 MEASUREMENT DISTANCE	30
3.2.7 TEST RESULTS (ABOVE 1 GHZ)	31
3.3 CONDUCTED EMISSION MEASUREMENT AT AC MAINS POWER PORTS	39
3.3.1 LIMITS	39
3.3.2 MEASUREMENT INSTRUMENTS LIST	39
3.3.3 TEST PROCEDURE	39
3.3.4 DEVIATION FROM TEST STANDARD	39
3.3.5 TEST SETUP	40
3.3.6 TEST RESULTS	41
<b>4 . EMC EMISSION TEST- EN 55032:2015+AC:2016</b>	<b>49</b>
4.1 RADIATED EMISSIONS UP TO 1 GHZ	49

<b>Table of Contents</b>	<b>Page</b>
4.1.1 LIMITS	49
4.1.2 MEASUREMENT INSTRUMENTS LIST	49
4.1.3 TEST PROCEDURE	50
4.1.4 DEVIATION FROM TEST STANDARD	50
4.1.5 TEST SETUP	50
4.1.6 MEASUREMENT DISTANCE	51
4.1.7 TEST RESULTS (UP TO 1 GHZ)	52
<b>4.2 RADIATED EMISSIONS ABOVE 1 GHZ</b>	<b>54</b>
4.2.1 LIMITS	54
4.2.2 TEST PROCEDURE	55
4.2.3 DEVIATION FROM TEST STANDARD	55
4.2.4 TEST SETUP	55
4.2.5 MEASUREMENT DISTANCE	56
4.2.6 TEST RESULTS (ABOVE 1 GHZ)	57
<b>4.3 CONDUCTED EMISSION MEASUREMENT AT AC MAINS POWER PORTS</b>	<b>59</b>
4.3.1 LIMITS	59
4.3.2 MEASUREMENT INSTRUMENTS LIST	59
4.3.3 TEST PROCEDURE	59
4.3.4 DEVIATION FROM TEST STANDARD	59
4.3.5 TEST SETUP	60
4.3.6 TEST RESULTS	61
<b>5 . HARMONIC AND FLICKER TEST</b>	<b>63</b>
<b>5.1 HARMONIC CURRENT EMISSIONS</b>	<b>63</b>
5.1.1 LIMITS	63
5.1.2 MEASUREMENT INSTRUMENTS LIST	63
5.1.3 TEST PROCEDURE	63
5.1.4 DEVIATION FROM TEST STANDARD	63
5.1.5 TEST SETUP	63
5.1.6 TEST RESULTS	64
<b>5.2 VOLTAGE CHANGES, VOLTAGE FLUCTUATIONS AND FLICKER TEST</b>	<b>67</b>
5.2.1 LIMITS	67
5.2.2 MEASUREMENT INSTRUMENTS LIST	67
5.2.3 TEST PROCEDURE	67
5.2.4 DEVIATION FROM TEST STANDARD	67
5.2.5 TEST SETUP	68
5.2.6 TEST RESULTS	69
<b>6 . EMC IMMUNITY TEST</b>	<b>70</b>
6.1 STANDARD COMPLIANCE/SEVERITY LEVEL/CRITERIA	70
6.2 GENERAL PERFORMANCE CRITERIA	72
6.3 ELECTROSTATIC DISCHARGE IMMUNITY TEST (ESD)	73
6.3.1 TEST SPECIFICATION	73

<b>Table of Contents</b>	<b>Page</b>
6.3.2 MEASUREMENT INSTRUMENTS	73
6.3.3 TEST PROCEDURE	73
6.3.4 DEVIATION FROM TEST STANDARD	74
6.3.5 TEST SETUP	74
6.3.6 TEST RESULTS	75
6.4 RADIATED, RADIO-FREQUENCY, ELECTROMAGNETIC FIELD IMMUNITY TEST (RS)	79
6.4.1 TEST SPECIFICATION	79
6.4.2 MEASUREMENT INSTRUMENTS	79
6.4.3 TEST PROCEDURE	79
6.4.4 DEVIATION FROM TEST STANDARD	79
6.4.5 TEST SETUP	80
6.4.6 TEST RESULTS	81
6.5 ELECTRICAL FAST TRANSIENT/BURST IMMUNITY TEST (EFT/BURST)	82
6.5.1 TEST SPECIFICATION	82
6.5.2 MEASUREMENT INSTRUMENTS	82
6.5.3 TEST PROCEDURE	82
6.5.4 DEVIATION FROM TEST STANDARD	82
6.5.5 TEST SETUP	83
6.5.6 TEST RESULTS	84
6.6 SURGE IMMUNITY TEST	85
6.6.1 TEST SPECIFICATION	85
6.6.2 MEASUREMENT INSTRUMENTS	85
6.6.3 TEST PROCEDURE	85
6.6.4 DEVIATION FROM TEST STANDARD	86
6.6.5 TEST SETUP	86
6.6.6 TEST RESULTS	87
6.7 IMMUNITY TO CONDUCTED DISTURBANCES, INDUCED BY RADIO-FREQUENCY FIELDS TEST (CS)	88
6.7.1 TEST SPECIFICATION	88
6.7.2 MEASUREMENT INSTRUMENTS	88
6.7.3 TEST PROCEDURE	88
6.7.4 DEVIATION FROM TEST STANDARD	88
6.7.5 TEST SETUP	89
6.7.6 TEST RESULTS	90
6.8 POWER FREQUENCY MAGNETIC FIELD IMMUNITY TEST (PFMF)	91
6.8.1 TEST SPECIFICATION	91
6.8.2 MEASUREMENT INSTRUMENTS	91
6.8.3 TEST PROCEDURE	91
6.8.4 DEVIATION FROM TEST STANDARD	91
6.8.5 TEST SETUP	92
6.8.6 TEST RESULTS	93
6.9 VOLTAGE DIPS, SHORT INTERRUPTIONS AND VOLTAGE VARIATIONS IMMUNITY	

<b>Table of Contents</b>	<b>Page</b>
<b>TEST</b>	<b>94</b>
<b>6.9.1 TEST SPECIFICATION</b>	<b>94</b>
<b>6.9.2 MEASUREMENT INSTRUMENTS</b>	<b>94</b>
<b>6.9.3 TEST PROCEDURE</b>	<b>94</b>
<b>6.9.4 DEVIATION FROM TEST STANDARD</b>	<b>94</b>
<b>6.9.5 TEST SETUP</b>	<b>95</b>
<b>6.9.6 TEST RESULTS</b>	<b>96</b>
<b>7 . EUT TEST PHOTO</b>	<b>97</b>

**REPORT ISSUED HISTORY**

Report Version	Description	Issued Date
R00	Compared with the previous report (BTL-EMC-1-1905C010), added new mainboard and all test items have been re-evaluated and recorded in the test report. In this test report only records the test results of the new mainboard, the original mainboards' test results please refer to original report.	Apr. 03, 2020

## 1. SUMMARY OF TEST RESULTS

Test procedures according to the technical standards:

Emission			
Standard(s)	Test Item		Result
EN 55032: 2012+AC:2013 EN 55032:2015 EN 55032:2015+AC:2016 AS/NZS CISPR 32:2015 AS/NZS CISPR 32:2013	Radiated emissions up to 1 GHz		PASS
	Radiated emissions above 1 GHz		PASS
	Radiated emissions from FM receivers		N/A
	Conducted emissions AC mains power port		PASS
	Asymmetric mode conducted emissions	AAN	N/A
		Current Probe	N/A
		CP+CVP	N/A
Conducted differential voltage emissions		N/A	

Standard(s)	Test Item	Result
IEC 61000-3-2:2014 EN 61000-3-2:2014	Harmonic current	PASS
IEC 61000-3-3:2013+A1:2017 EN 61000-3-3:2013+A1:2019	Voltage fluctuations (Flicker)	PASS

Immunity			
Standard(s)	Ref Standard(s)	Test Item	Result
EN 55024: 2010 EN 55024: 2010+A1:2015	IEC 61000-4-2:2008 / EN 61000-4-2:2009	ESD	PASS
	IEC 61000-4-3: 2006+A1:2007+A2:2010 / EN 61000-4-3: 2006+A1:2008+A2:2010	RS	PASS
	IEC 61000-4-4:2012 / EN 61000-4-4:2012	EFT	PASS
	IEC 61000-4-5: 2014+A1:2017 / EN 61000-4-5:2014+A1:2017	Surge	PASS
	IEC 61000-4-6:2013 / EN 61000-4-6:2014+AC:2015	CS	PASS
	IEC 61000-4-8:2009 / EN 61000-4-8:2010	PFMF	PASS
	IEC 61000-4-11: 2004+A1:2017 / EN 61000-4-11: 2004+A1:2017	Dip	PASS

NOTE:

(1) "N/A" denotes test is not applicable to this device.



## 1.1 TEST FACILITY

The test facilities used to collect the test data in this report is at the location of No.3, Jinshagang 1st Road, Shixia, Dalang Town, Dongguan, Guangdong, China.

## 1.2 MEASUREMENT UNCERTAINTY

Where relevant, the following measurement uncertainty levels have been estimated for tests performed on the EUT as specified in CISPR 16-4-2, The BTL measurement uncertainty is less than the CISPR 16-4-2  $U_{\text{CISPR}}$  requirement.

The reported uncertainty of measurement  $y \pm U$ , where expanded uncertainty  $U$  is based on a standard uncertainty multiplied by a coverage factor of  $k=2$ , providing a level of confidence of approximately **95%**.

### A. Radiated emissions up to 1 GHz measurement:

Test Site	Method	Measurement Frequency Range	Ant. H / V	U,(dB)
DG-CB08 (10m)	CISPR	30MHz ~ 200MHz	V	4.44
		30MHz ~ 200MHz	H	3.44
		200MHz ~ 1,000MHz	V	4.28
		200MHz ~ 1,000MHz	H	3.52

### B. Radiated emissions above 1 GHz measurement:

Test Site	Method	Measurement Frequency Range	U,(dB)
DG-CB08 (3m)	CISPR	1GHz ~ 6GHz	4.36

### C. Conducted emissions AC mains power port measurement:

Test Site	Method	Measurement Frequency Range	U,(dB)
DG-C01	CISPR	150kHz ~ 30MHz	2.90

### D. Harmonic/ Flicker Measurement:

Test Site	Method	Item	U (%)
DG-C01	EN 61000-3-2	Current	0.593
	EN 61000-3-3	Voltage	0.595

## E. Immunity Measurement:

Test Site	Method	Item	U
DG-SR02	IEC 61000-4-2	Rise time tr	6.80%
		Peak current Ip	6.30%
		Current at 30 ns	6.50%
		Current at 60 ns	6.90%
DG-CB05	IEC 61000-4-3	Electromagnetic field immunity test	2.38dB
		On-ear acoustic & Acoustic measurements on loudspeakers	2.40dB
		Electrical measurements	2.38dB
DG-SR05	IEC 61000-4-4	Peak voltage (V <sub>P</sub> )	3.7%
		Rise time (tr)	4.4%
		Pulse width(tw)	4.1%
		Pulse Freq.(kHz)	0.8%
		Burst Duration(ms)	1.4%
		Burst Period(ms)	1.4%
DG-SR05	IEC 61000-4-5	Open-Circuit Output Voltage (1.2/50us)	3.8%
		Open circuit front time (1.2/50us)	6.3%
		Open circuit time of half value (1.2/50us)	4.6%
DG-CB06	IEC 61000-4-6	CDN	1.32dB
		EM clamp	3.16dB
		On-ear acoustic & Acoustic measurements on loudspeakers	1.34dB
		Electrical measurements	1.32dB
DG-SR05	IEC 61000-4-8	Magnetic Field Level	3.787 %
DG-SR05	IEC 61000-4-11	DIP Amplitude	0.5%
		DIP Time Event	3%

Note: Unless specifically mentioned, the uncertainty of measurement has not been taken into account to declare the compliance or non-compliance to the specification.

### 1.3 TEST ENVIRONMENT CONDITIONS

Test Item	Temperature	Humidity	Tested By
Radiated emissions up to 1 GHz	25°C	60%	Dylan Hong
Radiated emissions above 1 GHz	25°C	60%	Dylan Hong
Conducted emissions AC mains power port	25°C	53%	Bang Liang
Harmonic current	25°C	53%	Bang Liang
Voltage fluctuations (Flicker)	25°C	53%	Bang Liang

Test Item	Temperature	Humidity	Pressure	Tested By
ESD	24°C	48%	1016hPa	Albert Huang
RS	25°C	54%	/	Hunter Xu
EFT	25°C	51%	/	Maggie Peng
Surge	25°C	51%	/	Maggie Peng
CS	24°C	56%	/	Daniel Li
PFMF	25°C	51%	/	Maggie Peng
Dip	25°C	51%	/	Maggie Peng

## 2. GENERAL INFORMATION

### 2.1 GENERAL DESCRIPTION OF EUT

Equipment	LCD Monitor
Brand Name	N/A
Test Model	**27G2*****(*=A-Z,a-z,0-9,/ , +,-,\ or blank)
Series Model	N/A
Model Difference(s)	Only differ in model name due to marketing purpose
Power Source	AC Mains.
Power Rating	100-240V~ 50-60Hz
Connecting I/O Port(s)	1* AC port 1* D-SUB port 2* HDMI port 1* DP port 1* Earphone port 5* USB port 1* Aduio port
Classification Of EUT	Class B
Highest Internal Frequency(Fx)	600MHz

Cable Type	Shielded Type	Ferrite Core	Length(m)	Note
D-SUB	Shielded	YES	1.8/1.5	Bonded two Ferrite Cores
HDMI	Shielded	NO	1.8/1.5	
DP	Shielded	NO	1.8/1.5	
AC Power Cord	Non-shielded	NO	1.8/1.5	

**Note:**

1. For a more detailed features description, please refer to the manufacturer's specifications or the user's manual.
2. Power cable 1.8m, 1.5m length, worst case is Power cable 1.8m with D-SUB+HDMI+DP 1.8m length testing and recording in test report.

## 2.2 DESCRIPTION OF TEST MODES

To investigate the maximum EMI emission characteristics generates from EUT, the test system was pre-scanning tested base on the consideration of following EUT operation mode or test configuration mode which possible have effect on EMI emission level. Each of these EUT operation mode(s) or test configuration mode(s) mentioned above was evaluated respectively.

Pretest Mode	Description
Mode 1	D-SUB 1920*1080/60Hz
Mode 2	DP1920*1080/144Hz
Mode 3	HDMI 1 1920*1080/144Hz
Mode 4	HDMI 2 1920*1080/144Hz
Mode 5	HDMI 1 1080P
Mode 6	HDMI 2 1080P
Mode 7	HDMI 1 1024*768/60Hz
Mode 8	HDMI 1 640*480/60Hz

For Radiated Test	
Final Test Mode	Description
Mode 1	D-SUB 1920*1080/60Hz
Mode 3	HDMI 1 1920*1080/144Hz
Mode 5	HDMI 1 1080P

For Conducted Test	
Final Test Mode	Description
Mode 1	D-SUB 1920*1080/60Hz
Mode 3	HDMI 1 1920*1080/144Hz
Mode 5	HDMI 1 1080P

For Harmonics / Flicks Test	
Final Test Mode	Description
Mode 3	HDMI 1 1920*1080/144Hz

For EMS Test	
Final Test Mode	Description
Mode 1	D-SUB 1920*1080/60Hz
Mode 2	DP1920*1080/144Hz
Mode 3	HDMI 1 1920*1080/144Hz
Mode 4	HDMI 2 1920*1080/144Hz
Mode 5	HDMI 1 1080P
Mode 6	HDMI 2 1080P
Mode 7	HDMI 1 1024*768/60Hz
Mode 8	HDMI 1 640*480/60Hz

Evaluation description:

1. The maximum resolution is evaluated Mode 1-6. The worst case is Mode 3 and evaluated the middle and low resolution Mode 7 and mode 8.
2. According to the client's requirement, choose Mode 1, Mode 3, Mode 5 and recorded in test report.

### 2.3 EUT OPERATING CONDITIONS

The EUT exercise program used during radiated and/or conducted emission measurement was designed to exercise the various system components in a manner similar to a typical use. The standard test signals and output signal as following:

1. EUT connected to Earphone via Earphone cable.
2. EUT connected to PC via D-SUB & HDMI & DP & USB & Audio cable.
3. PC connected to Mouse and Keyboard via USB cable.
4. The USB Hard Disk connected to EUT via USB cable.

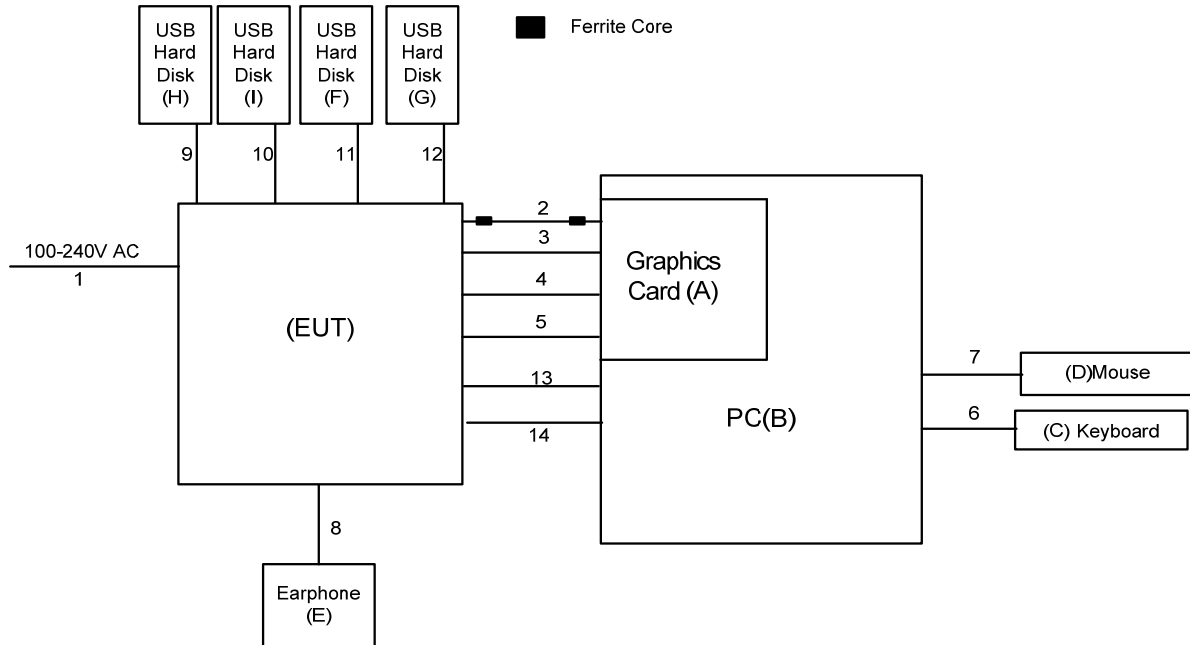
**2.4 BLOCK DIAGRAM SHOWING THE CONFIGURATION OF SYSTEM TESTED**

## 2.5 DESCRIPTION OF SUPPORT UNITS

The EUT has been tested as an independent unit together with other necessary accessories or support units. The following support units or accessories were used to form a representative test configuration during the tests.

Item	Equipment	Mfr/Brand	Model/Type No.	Series No.
A	Graphics Card	DELL	ATI 3650	260832000932
B	PC	DELL	Vostro 470	28747261333
C	Keyboard	DELL	KB212-B	CN0HTXH97158125004DXA01
D	Mouse	Lenovo	M-SBF96	8B4643223001509
E	Earphone	Apple	N/A	N/A
F	USB Hard Disk	LACIE	Lacie S.A	NL33PVK4
G	USB Hard Disk	LACIE	Lacie S.A	NL33PVLH
H	USB Hard Disk	LACIE	Lacie S.A	NL33PVLS
I	USB Hard Disk	LACIE	Lacie S.A	NL34BJRF

Item	Cable Type	Shielded Type	Ferrite Core	Length
1	AC Cable	NO	NO	1.8m/1.5m
2	D-SUB Cable	YES	YES	1.8m/1.5m
3	DP Cable	YES	NO	1.8m/1.5m
4	HDMI Cable	YES	NO	1.8m/1.5m
5	HDMI Cable	YES	NO	1.8m/1.5m
6	USB Cable	YES	NO	1.8m
7	USB Cable	YES	NO	1.8m
8	Earphone Cable	NO	NO	1.2m
9-12	USB Cable	NO	NO	0.5m
13	USB Cable	YES	NO	1.5m
14	Audio Cable	NO	NO	1.5m



### 3. EMC EMISSION TEST- EN55032:2012+AC:2013 & 2015

#### 3.1 RADIATED EMISSION

##### 3.1.1 LIMITS

Class B equipment up to 1000MHz

Frequency MHz	Measurement		Class B limit dB(uV/m)
	Distance m	Detector type/bandwidth	SAC
30-230	10	Quasi peak / 120 kHz	30
230-1000			37

Notes:

- (1) The limit for radiated test was performed according to as following: EN 55032
- (2) The tighter limit applies at the band edges.
- (3) Emission level (dBuV/m)=20log Emission level (uV/m).
- (4) The test result calculated as following:  
 Measurement Value = Reading Level + Correct Factor  
 Correct Factor = Antenna Factor + Cable Loss - Amplifier Gain(if use)  
 Margin Level = Measurement Value - Limit Value

##### 3.1.2 MEASUREMENT INSTRUMENTS LIST

Item	Kind of Equipment	Manufacturer	Type No.	Serial No.	Calibrated until
1	Receiver	Keysight	N9038A	MY54450004	Aug. 03, 2020
2	MXE EMI Receiver	Agilent	N9038A	MY53220133	Feb. 28, 2021
3	Pre-Amplifier	EMC INSTRUMENT	EMC 9135	980284	Mar. 01, 2021
4	Pre-Amplifier	EMC INSTRUMENT	EMC 9135	980283	Mar. 01, 2021
5	Trilog-Broadband Antenna	Schwarzbeck	VULB9168	946	Oct. 26, 2020
6	Trilog-Broadband Antenna	Schwarzbeck	VULB9168	947	Dec. 02, 2020
7	Cable	emci	LMR-400(5m+1 1m+15m)	N/A	Nov. 22, 2020
8	Cable	emci	LMR-400(5m+8 m+8m)	N/A	Nov. 22, 2020
9	Measurement Software	Farad	EZ-EMC Ver.BTL-2ANT-1	N/A	N/A
10	Multi-Device Controller	ETS-Lindgren	2090	N/A	N/A
11	Attenuator	EMCI	EMCI-N-6-06	N0670	Dec. 02, 2020
12	Attenuator	EMCI	EMCI-N-6-06	N0671	Oct. 26, 2020

Remark: "N/A" denotes no model no., no serial no. or no calibration specified.

All calibration period of equipment list is one year.

### 3.1.3 TEST PROCEDURE

- The measuring distance of 10 m shall be used for measurements. The EUT was placed on the top of a rotating table 0.8 meter above the ground at a 10 meter semi-anechoic chamber. The table was rotated 360 degrees to determine the position of the highest radiation.(below 1GHz).
- The height of the equipment or of the substitution antenna shall be 0.8 m, the height of the test antenna shall vary between 1 m to 4 m. Both horizontal and vertical polarizations of the antenna are set to make the measurement.
- The initial step in collecting radiated emission data is a receiver peak detector mode pre-scanning the measurement frequency range. Significant peaks are then marked and then Quasi Peak detector mode re-measured.
- All readings are Peak unless otherwise stated QP in column of Note. Peak denotes that the Peak reading compliance with the QP Limits and then QP Mode measurement didn't perform.  
(below 1GHz)
- For the actual test configuration, please refer to the related Item - Block Diagram of system tested.

### 3.1.4 DEVIATION FROM TEST STANDARD

No deviation

### 3.1.5 TEST SETUP

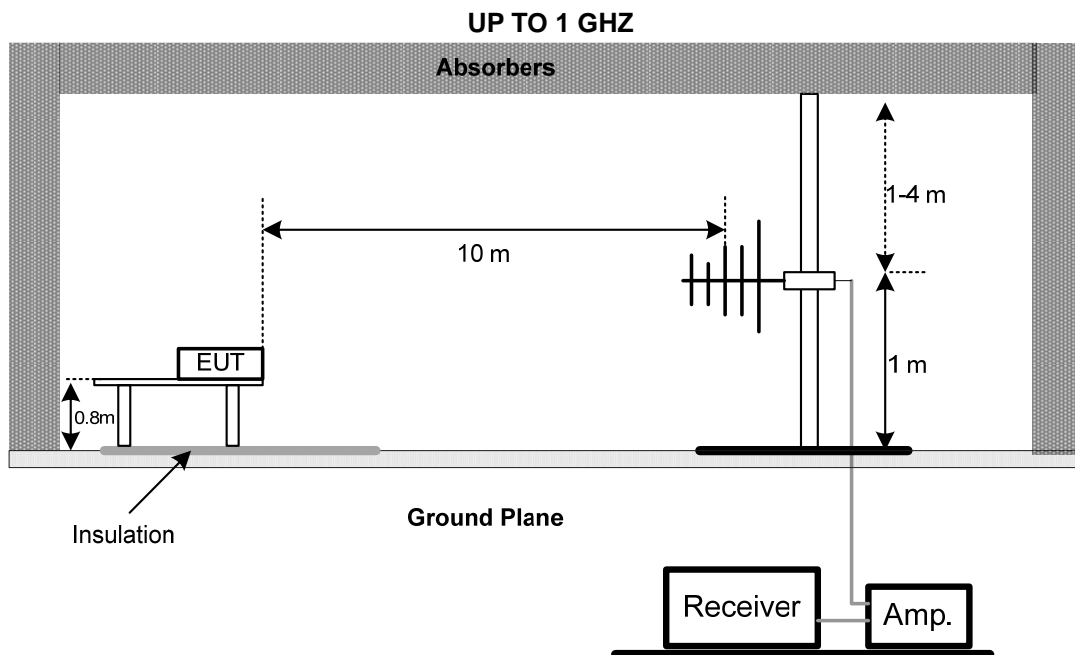

Note: The antenna can be moved between 1 to 4 meters above the ground.

### 3.1.6 MEASUREMENT DISTANCE

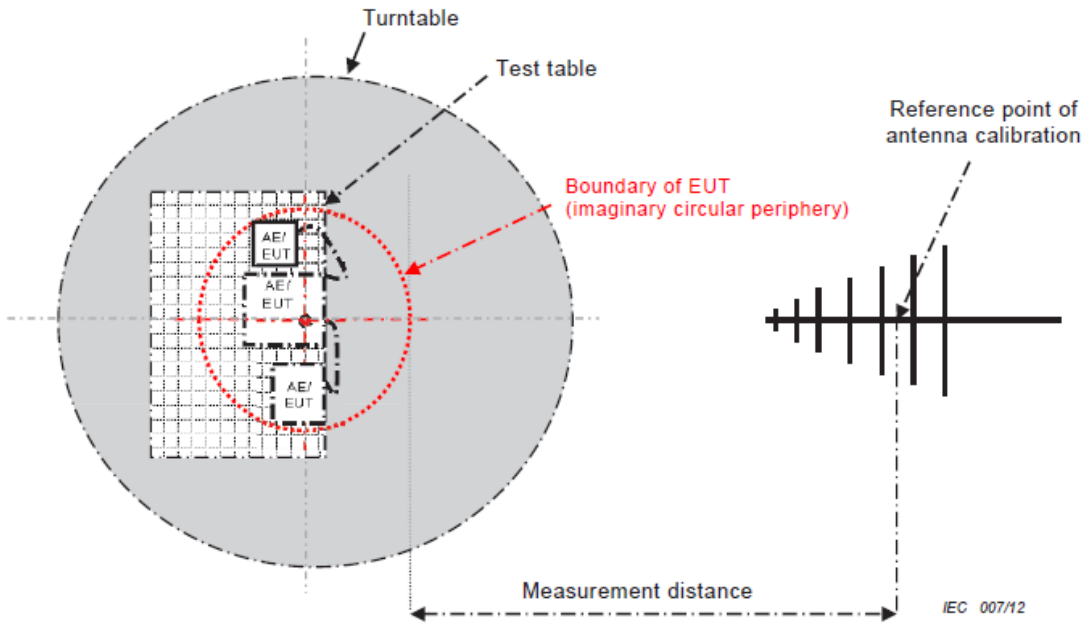

- 34 -

CISPR 32 © IEC:2012

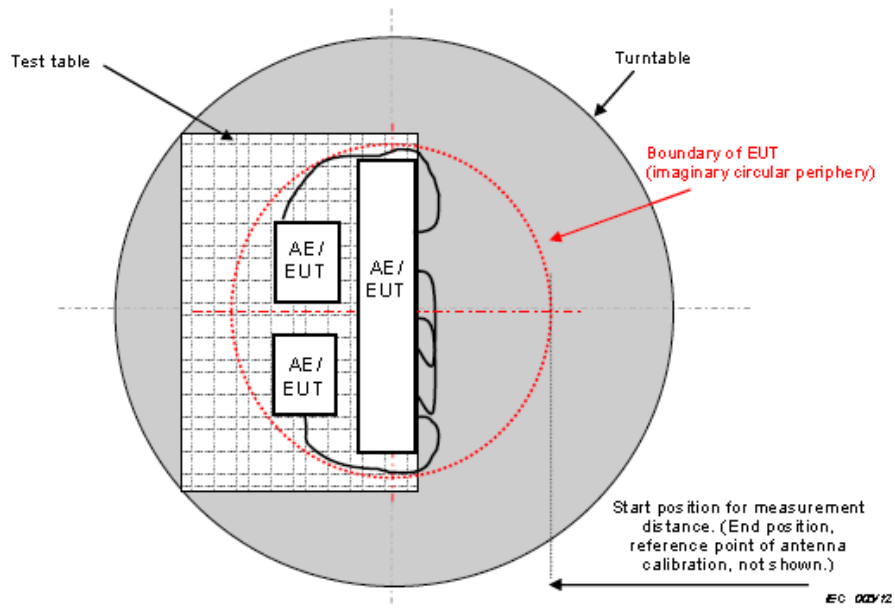
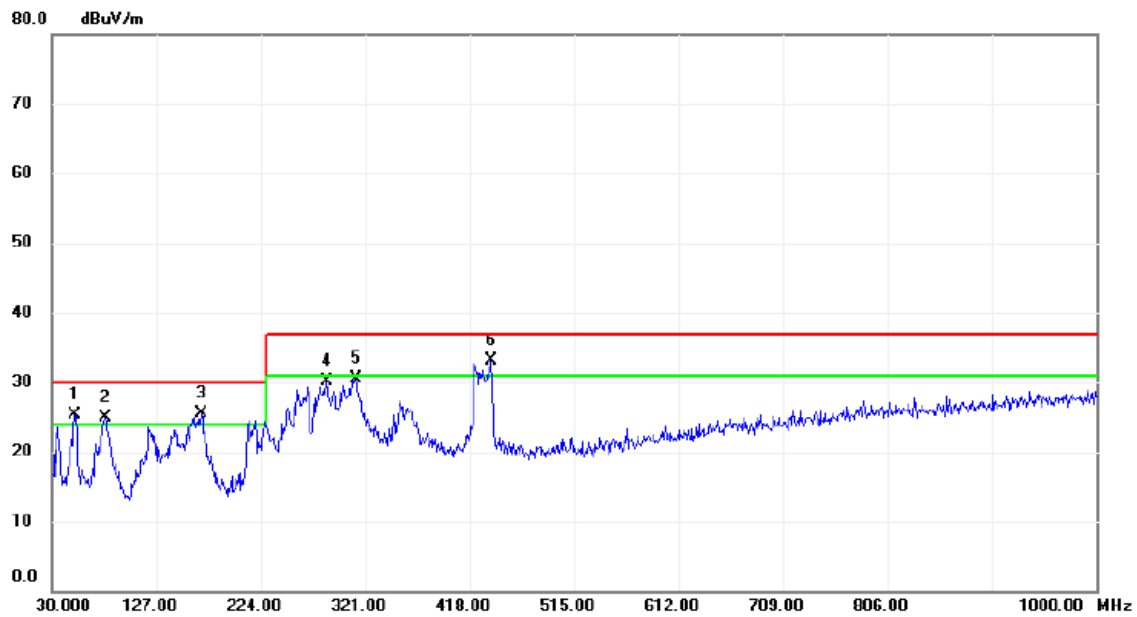

Figure C.2 – Boundary of EUT, Local AE and associated cabling

### 3.1.7 TEST RESULTS (UP TO 1 GHZ)

Test Voltage	AC 230V/50Hz	Polarization	Vertical
Test Mode	Mode 1		



No.	Mk.	Freq. MHz	Reading Level dBuV	Correct Factor dB	Measure- ment dBuV/m	Limit dBuV/m	Margin dB	Detector	Comment
1	!	51.3400	42.11	-16.72	25.39	30.00	-4.61	QP	
2	!	79.4700	43.30	-18.36	24.94	30.00	-5.06	QP	
3	!	168.7100	41.28	-15.85	25.43	30.00	-4.57	QP	
4		285.1100	45.28	-15.13	30.15	37.00	-6.85	QP	
5		312.2700	44.79	-14.38	30.41	37.00	-6.59	QP	
6	*	437.4000	44.56	-11.44	33.12	37.00	-3.88	QP	

Test Voltage	AC 230V/50Hz	Polarization	Horizontal
Test Mode	Mode 1		

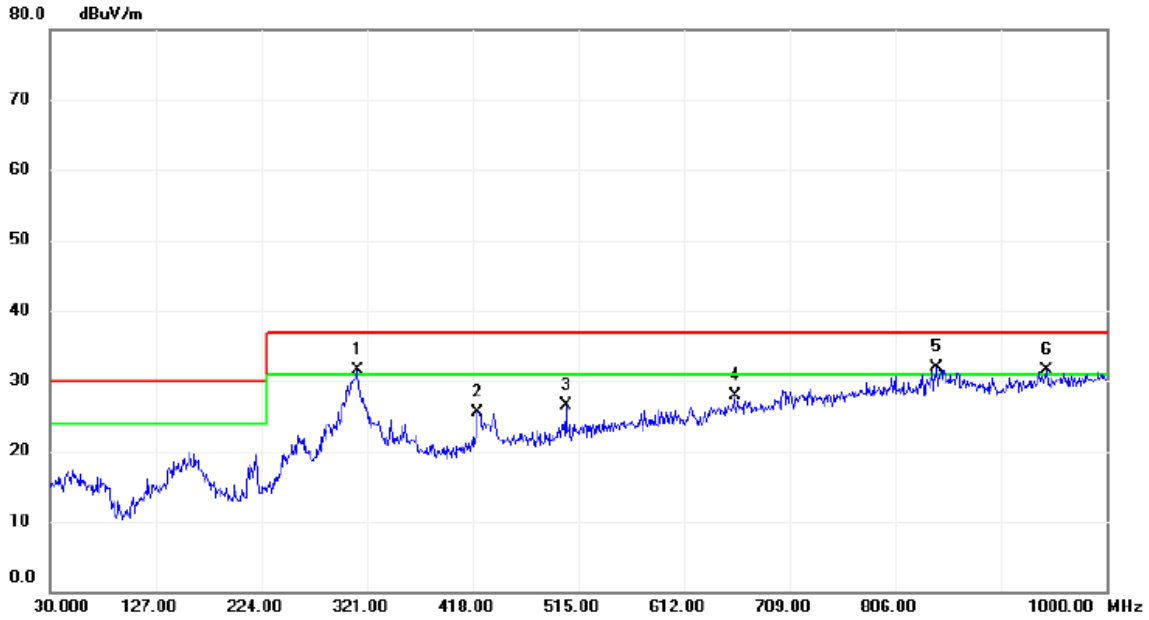

No.	Mk.	Freq. MHz	Reading Level dBuV	Correct Factor dB	Measure- ment dBuV/m	Limit dBuV/m	Margin dB	Detector	Comment
1	!	312.2700	45.56	-14.11	31.45	37.00	-5.55	QP	
2		422.8500	36.93	-11.42	25.51	37.00	-11.49	QP	
3		503.3600	36.17	-9.64	26.53	37.00	-10.47	QP	
4		658.5600	34.47	-6.54	27.93	37.00	-9.07	QP	
5	*	843.8300	35.69	-3.87	31.82	37.00	-5.18	QP	
6	!	944.7100	33.52	-2.09	31.43	37.00	-5.57	QP	

Test Voltage	AC 230V/50Hz	Polarization	Vertical
Test Mode	Mode 3		

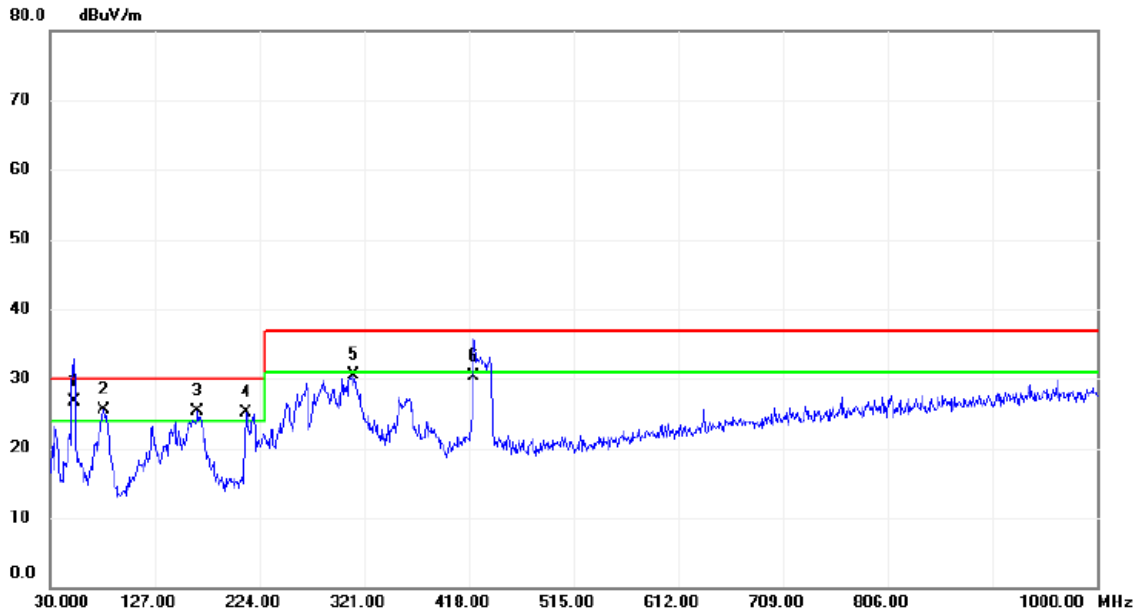

No.	Mk.	Freq. MHz	Reading Level dBuV	Correct Factor dB	Measure- ment dBuV/m	Limit dBuV/m	Margin dB	Detector	Comment
1	*	52.3100	43.42	-16.72	26.70	30.00	-3.30	QP	
2	!	79.4700	43.89	-18.36	25.53	30.00	-4.47	QP	
3	!	166.7700	41.13	-15.81	25.32	30.00	-4.68	QP	
4	!	211.3900	43.70	-18.65	25.05	30.00	-4.95	QP	
5		311.3000	44.98	-14.42	30.56	37.00	-6.44	QP	
6		422.8500	42.23	-11.83	30.40	37.00	-6.60	QP	

Test Voltage	AC 230V/50Hz	Polarization	Horizontal
Test Mode	Mode 3		

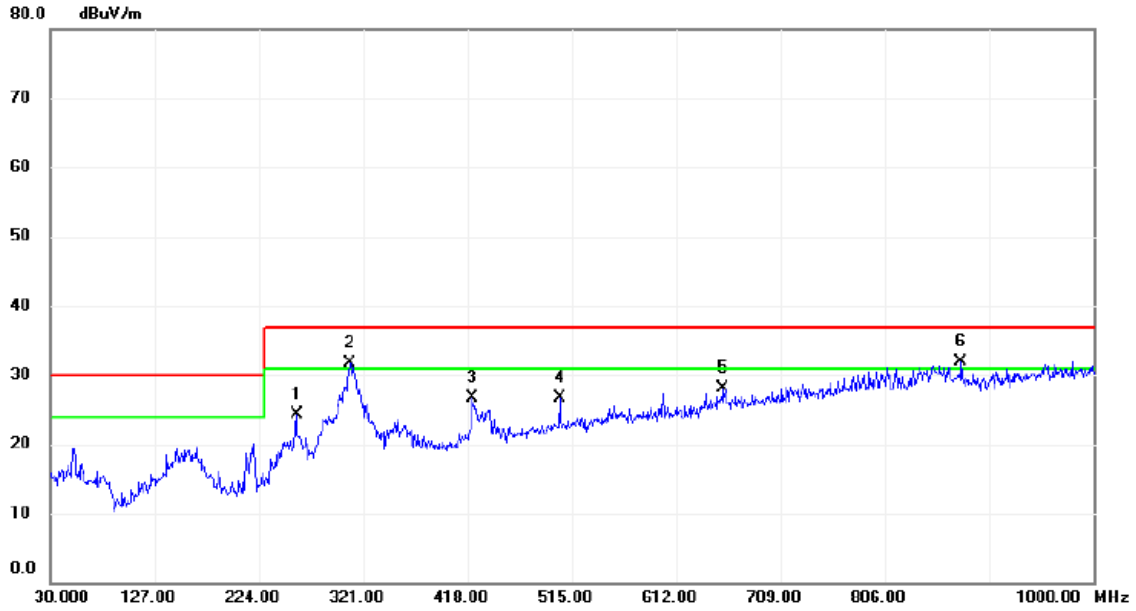

No.	Mk.	Freq. MHz	Reading Level dBuV	Correct Factor dB	Measure- ment dBuV/m	Limit dBuV/m	Margin dB	Detector	Comment
1		258.9200	40.59	-16.21	24.38	37.00	-12.62	QP	
2	!	308.3900	46.02	-14.25	31.77	37.00	-5.23	QP	
3		422.8500	38.07	-11.42	26.65	37.00	-10.35	QP	
4		503.3600	36.35	-9.64	26.71	37.00	-10.29	QP	
5		655.6500	34.60	-6.59	28.01	37.00	-8.99	QP	
6	*	876.8100	35.31	-3.44	31.87	37.00	-5.13	QP	

Test Voltage	AC 230V/50Hz	Polarization	Vertical
Test Mode	Mode 5		

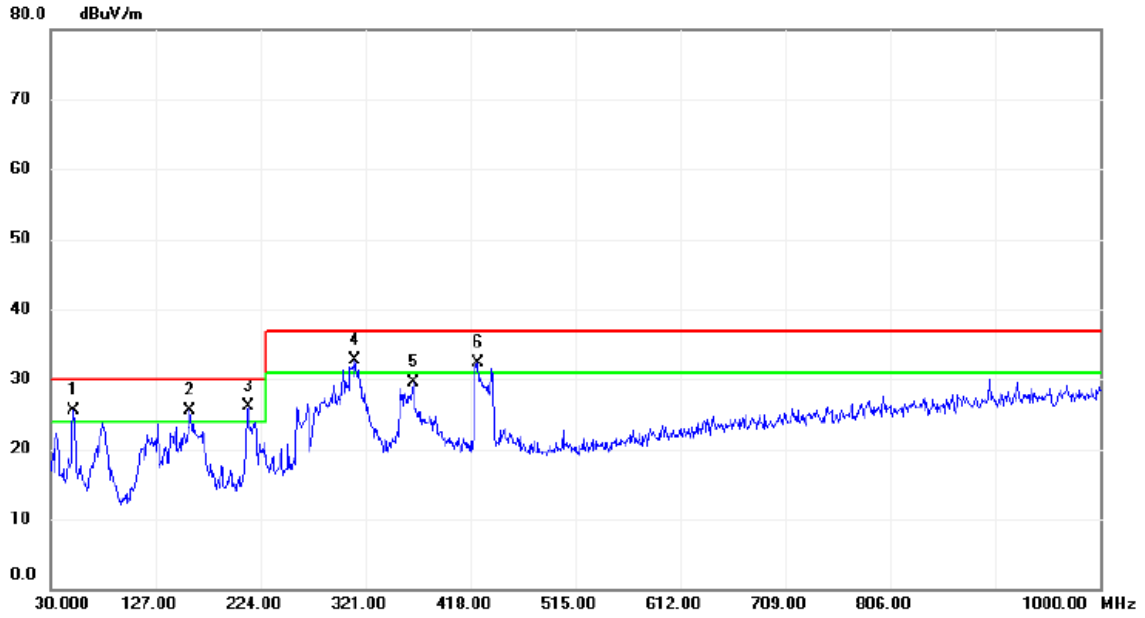

No.	Mk.	Freq. MHz	Reading Level dBuV	Correct Factor dB	Measure- ment dBuV/m	Limit dBuV/m	Margin dB	Detector	Comment
1	!	51.3400	42.15	-16.72	25.43	30.00	-4.57	QP	
2	!	159.0100	41.07	-15.66	25.41	30.00	-4.59	QP	
3	*	212.3600	44.85	-18.67	26.18	30.00	-3.82	QP	
4	!	311.3000	47.03	-14.42	32.61	37.00	-4.39	QP	
5		365.6200	42.74	-13.21	29.53	37.00	-7.47	QP	
6	!	424.7900	44.01	-11.78	32.23	37.00	-4.77	QP	



Test Voltage	AC 230V/50Hz	Polarization	Horizontal
Test Mode	Mode 5		

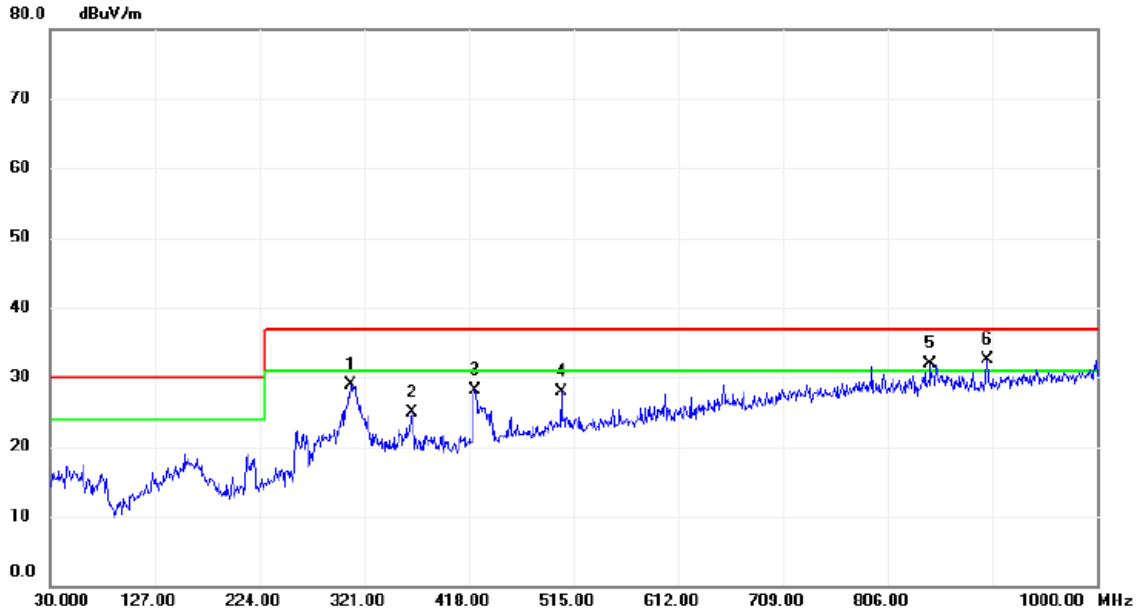

No.	Mk.	Freq. MHz	Reading Level dBuV	Correct Factor dB	Measure- ment dBuV/m	Limit dBuV/m	Margin dB	Detector	Comment
1		308.3900	43.20	-14.25	28.95	37.00	-8.05	QP	
2		365.6200	37.73	-12.90	24.83	37.00	-12.17	QP	
3		423.8200	39.48	-11.39	28.09	37.00	-8.91	QP	
4		503.3600	37.52	-9.64	27.88	37.00	-9.12	QP	
5	!	845.7700	35.69	-3.83	31.86	37.00	-5.14	QP	
6	*	898.1500	35.60	-3.17	32.43	37.00	-4.57	QP	

Test Voltage	AC 110V/60Hz	Polarization	Vertical
Test Mode	Mode 3		

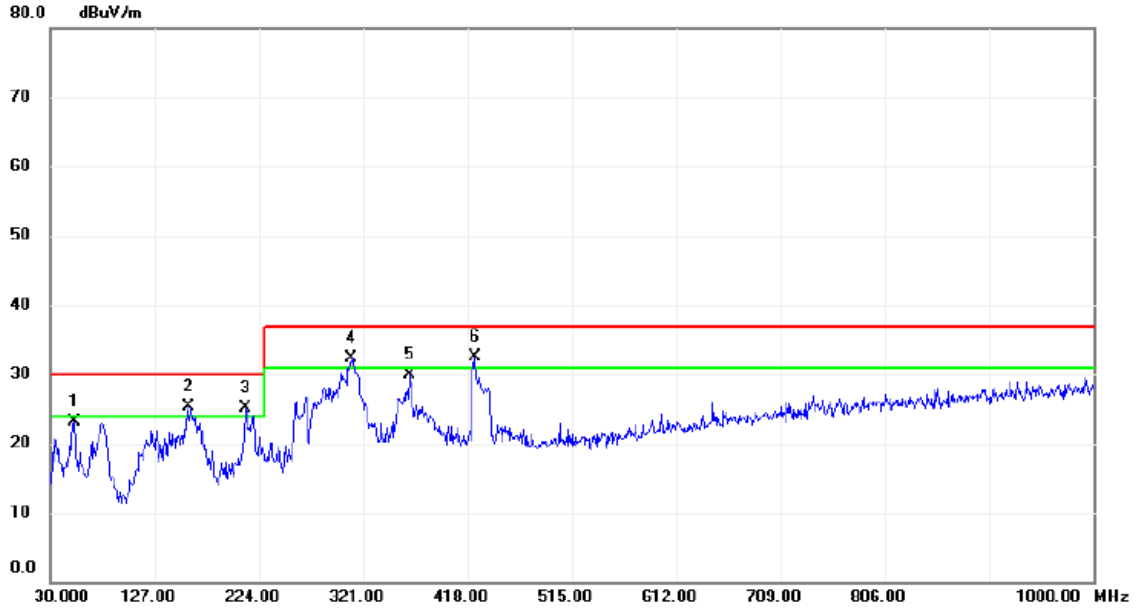

No.	Mk.	Freq. MHz	Reading Level dBuV	Correct Factor dB	Measure- ment dBuV/m	Limit dBuV/m	Margin dB	Detector	Comment
1		52.3100	39.79	-16.72	23.07	30.00	-6.93	QP	
2	!	158.0400	40.91	-15.67	25.24	30.00	-4.76	QP	
3	!	211.3900	43.79	-18.65	25.14	30.00	-4.86	QP	
4	!	310.3300	46.79	-14.45	32.34	37.00	-4.66	QP	
5		363.6800	43.19	-13.29	29.90	37.00	-7.10	QP	
6	*	424.7900	44.25	-11.78	32.47	37.00	-4.53	QP	

Test Voltage	AC 110V/60Hz	Polarization	Horizontal
Test Mode	Mode 3		

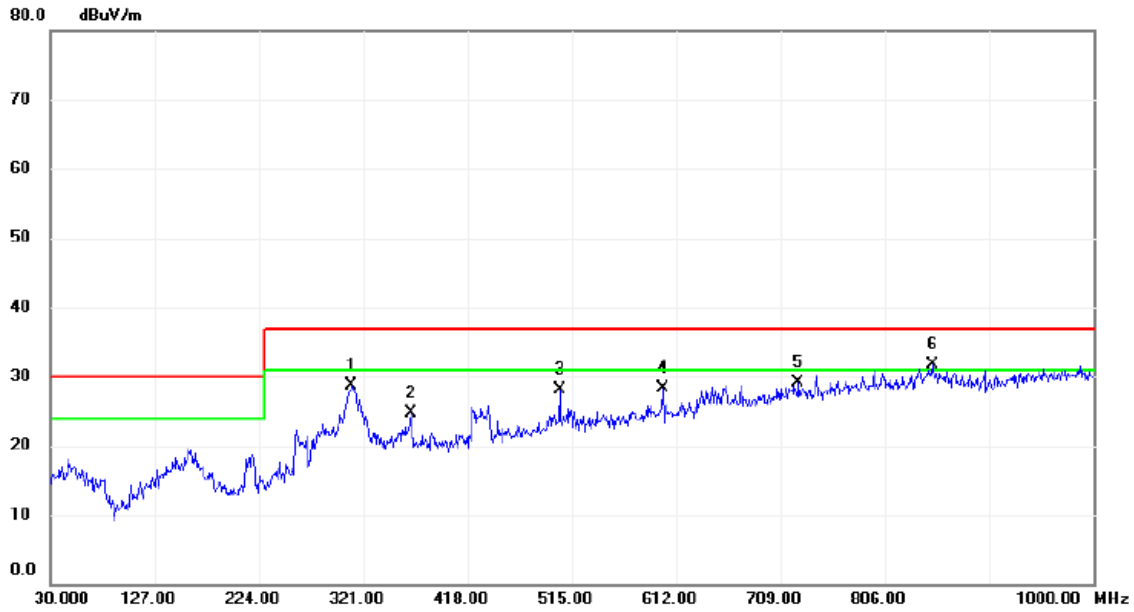

No.	Mk.	Freq. MHz	Reading Level dBuV	Correct Factor dB	Measure- ment dBuV/m	Limit dBuV/m	Margin dB	Detector	Comment
1		310.3300	42.80	-14.18	28.62	37.00	-8.38	QP	
2		365.6200	37.56	-12.90	24.66	37.00	-12.34	QP	
3		503.3600	37.75	-9.64	28.11	37.00	-8.89	QP	
4		599.3900	35.62	-7.39	28.23	37.00	-8.77	QP	
5		725.4900	34.46	-5.35	29.11	37.00	-7.89	QP	
6	*	850.6200	35.40	-3.79	31.61	37.00	-5.39	QP	

### 3.2 RADIATED EMISSION ABOVE 1 GHZ

#### 3.2.1 LIMITS

Class B equipment above 1000MHz

Frequency MHz	Measurement		Class B limit dB(uV/m)
	Distance m	Detector type/bandwidth	FSOATS
1000-3000	3	Average / 1 MHz	50
3000-6000			54
1000-3000		Peak / 1 MHz	70
3000-6000			74

Notes:

- (1) The limit for radiated test was performed according to as following: EN 55032
- (2) The tighter limit applies at the band edges.
- (3) Emission level (dBuV/m)=20log Emission level (uV/m).
- (4) The test result calculated as following:  
 Measurement Value = Reading Level + Correct Factor  
 Correct Factor = Antenna Factor + Cable Loss - Amplifier Gain(if use)  
 Margin Level = Measurement Value - Limit Value

Required highest frequency for radiated measurement

Highest internal frequency ( $F_x$ ) MHz	Highest measured frequency MHz
$F_x \leq 108$	1000
$108 < F_x \leq 500$	2000
$500 < F_x \leq 1000$	5000
$F_x > 1000$	5 <sup>th</sup> up to a maximum 6 GHz,

Note for FM and TV broadcast receiver,  $F_x$  is determined from the highest frequency generated or used excluding the local oscillator and tuned frequencies.

#### 3.2.2 MEASUREMENT INSTRUMENTS LIST

Item	Kind of Equipment	Manufacturer	Type No.	Series Model	Calibrated until
1	Double Ridged Guide Antenna	ETS	3115	75846	Mar. 19, 2021
2	Amplifier	Agilent	8449B	3008A02333	Mar. 01, 2021
3	MXE EMI Receiver	Agilent	N9038A	MY53220133	Feb. 28, 2021
4	Measurement Software	Farad	EZ-EMC Ver.BTL-2ANT-1	N/A	N/A
5	Multi-Device Controller	ETS-Lindgren	2090	N/A	N/A
6	Controller	MF	MF-7802	MF780208159	N/A
7	Cable	Micable Inc.	B10-01-01-5M	18047123	Feb. 28, 2021
8	Cable	Micable Inc.	B10-01-01-12M	18072743	Feb. 28, 2021
9	Cable	RegalWay	RWLPS50-7.9A- SMSM-1M	20200102 001	Feb. 28, 2021

Remark: "N/A" denotes no model no., no serial no. or no calibration specified.  
 All calibration period of equipment list is one year.

### 3.2.3 TEST PROCEDURE

- The measuring distance of 3 m shall be used for measurements. The EUT was placed on the top of a rotating table 0.8 meter above the ground at a 10 meter semi-anechoic chamber. The table was rotated 360 degrees to determine the position of the highest radiation. (above 1GHz)
- The height of the equipment or of the substitution antenna shall be 0.8 m, the height of the test antenna shall vary between 1 m to 4 m. Both horizontal and vertical polarizations of the antenna are set to make the measurement.
- The initial step in collecting radiated emission data is a receiver peak detector mode pre-scanning the measurement frequency range. Significant peaks are then marked and then Quasi Peak detector mode re-measured.
- All readings are Peak Mode value unless otherwise stated AVG in column of Note. If the Peak Mode Measured value compliance with the Peak Limits and lower than AVG Limits, the EUT shall be deemed to meet both Peak & AVG Limits and then only Peak Mode was measured, but AVG Mode didn't perform. (above 1GHz)
- For the actual test configuration, please refer to the related Item - Block Diagram of system tested.

### 3.2.4 DEVIATION FROM TEST STANDARD

No deviation

### 3.2.5 TEST SETUP

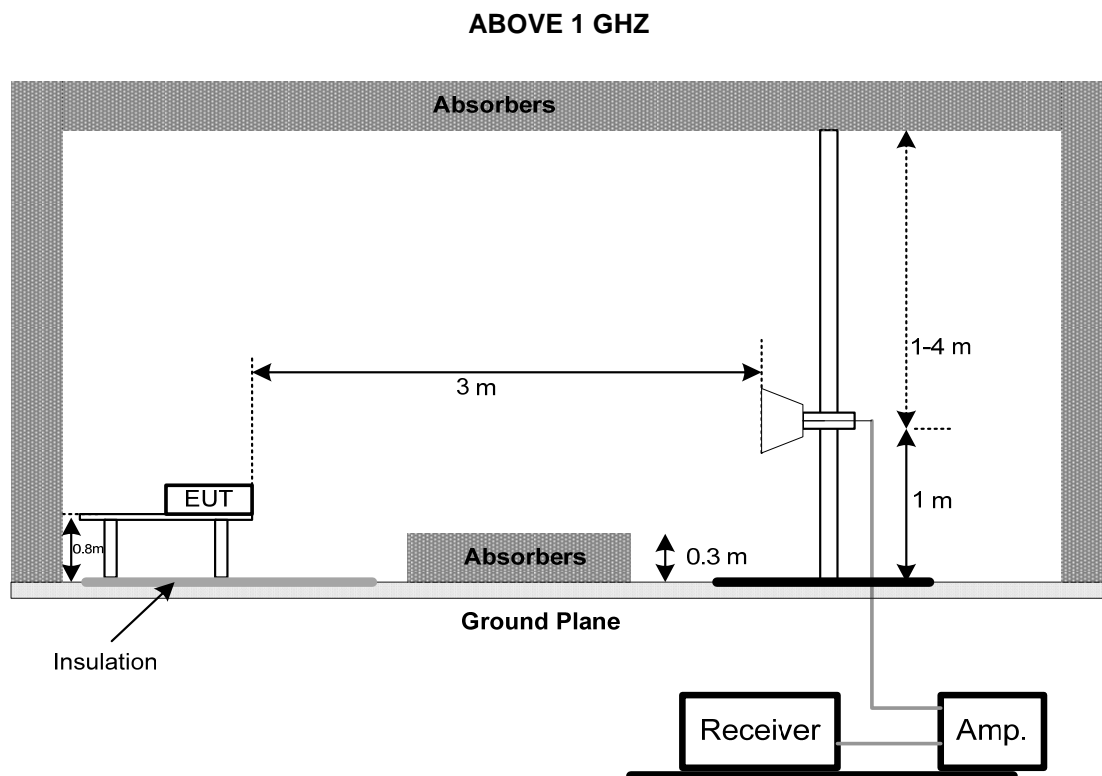

**3.2.6 MEASUREMENT DISTANCE**

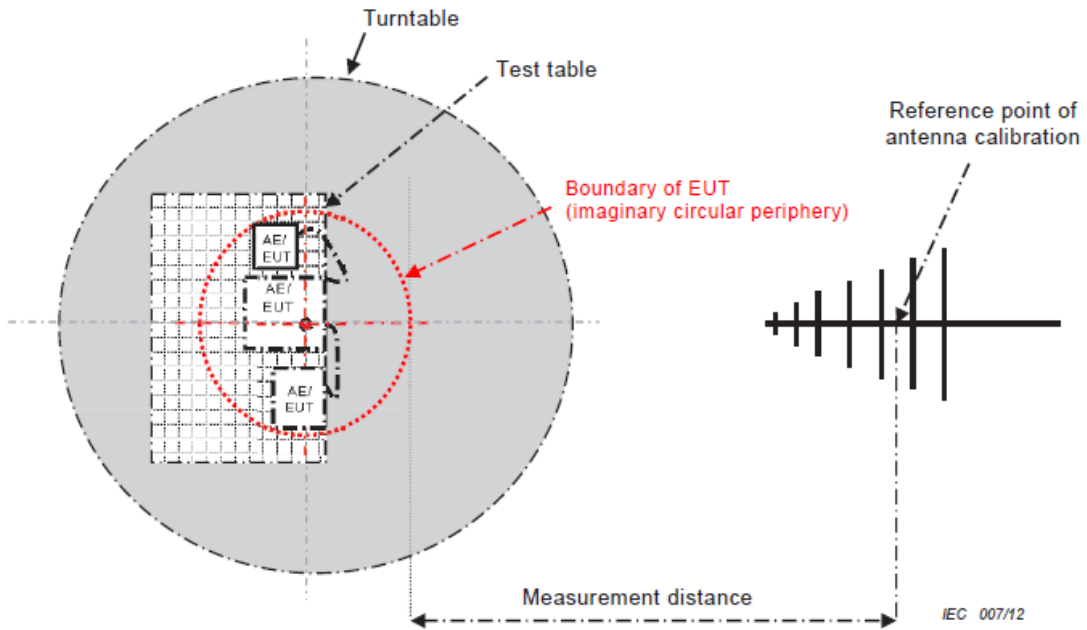

- 34 -

CISPR 32 © IEC:2012

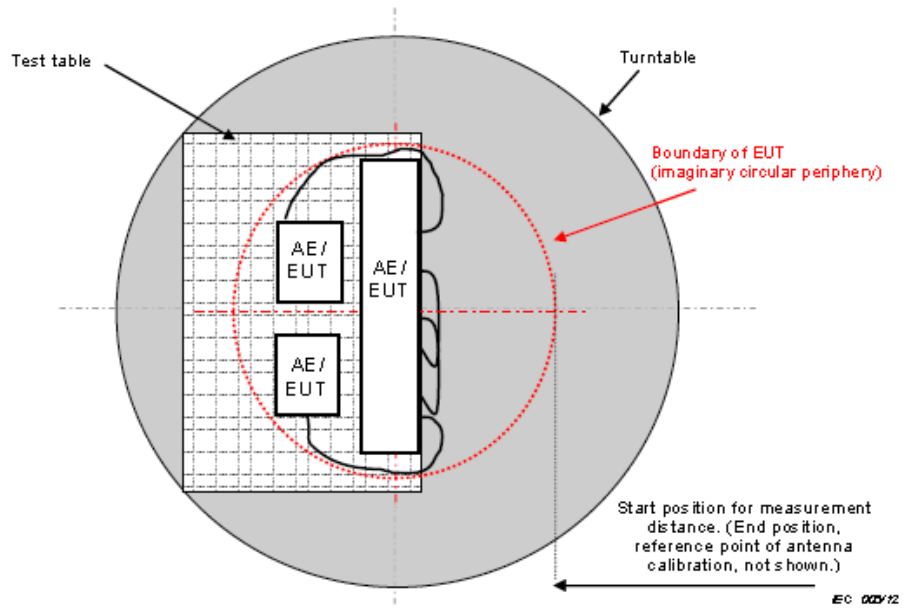

**Figure C.2 – Boundary of EUT, Local AE and associated cabling**

### 3.2.7 TEST RESULTS (ABOVE 1 GHZ)

Test Voltage	AC 230V/50Hz	Polarization	Vertical
Test Mode	Mode 1		

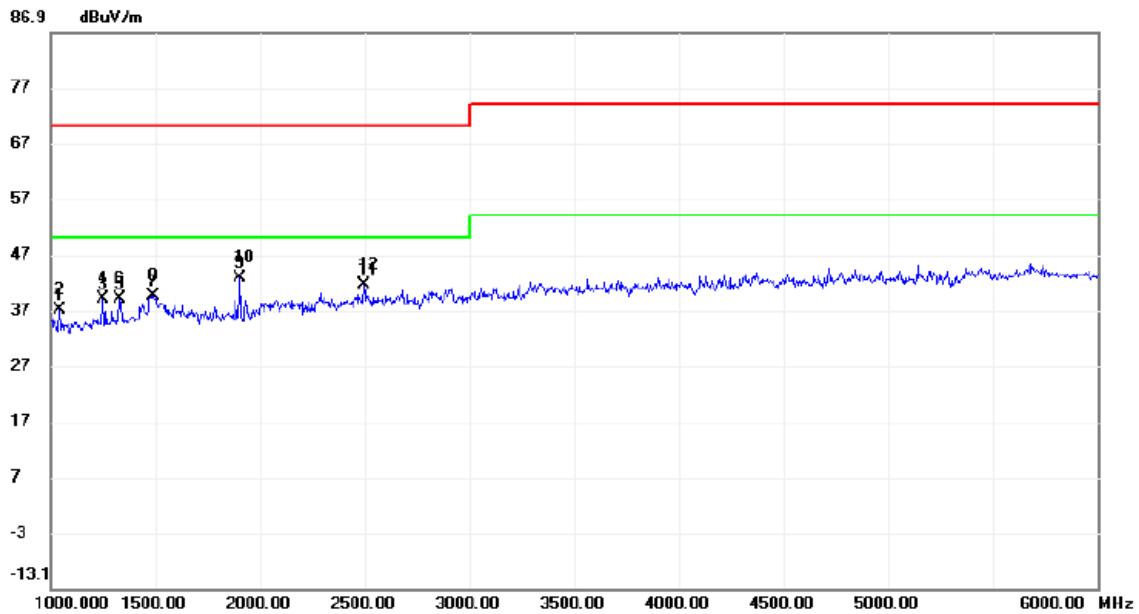

No.	Mk.	Freq. MHz	Reading Level dBuV	Correct Factor dB	Measure- ment dBuV/m	Limit dBuV/m	Margin dB	Detector	Comment
1		1040.000	43.92	-6.77	37.15	70.00	-32.85	peak	
2		1040.000	43.92	-6.77	37.15	50.00	-12.85	AVG	
3		1250.000	44.38	-5.31	39.07	70.00	-30.93	peak	
4		1250.000	44.38	-5.31	39.07	50.00	-10.93	AVG	
5		1330.000	43.81	-4.74	39.07	70.00	-30.93	peak	
6		1330.000	43.81	-4.74	39.07	50.00	-10.93	AVG	
7		1492.500	43.18	-3.61	39.57	70.00	-30.43	peak	
8		1492.500	43.18	-3.61	39.57	50.00	-10.43	AVG	
9		1905.000	44.84	-2.18	42.66	70.00	-27.34	peak	
10	*	1905.000	44.84	-2.18	42.66	50.00	-7.34	AVG	
11		2497.500	41.28	0.18	41.46	70.00	-28.54	peak	
12		2497.500	41.28	0.18	41.46	50.00	-8.54	AVG	

Test Voltage	AC 230V/50Hz	Polarization	Horizontal
Test Mode	Mode 1		

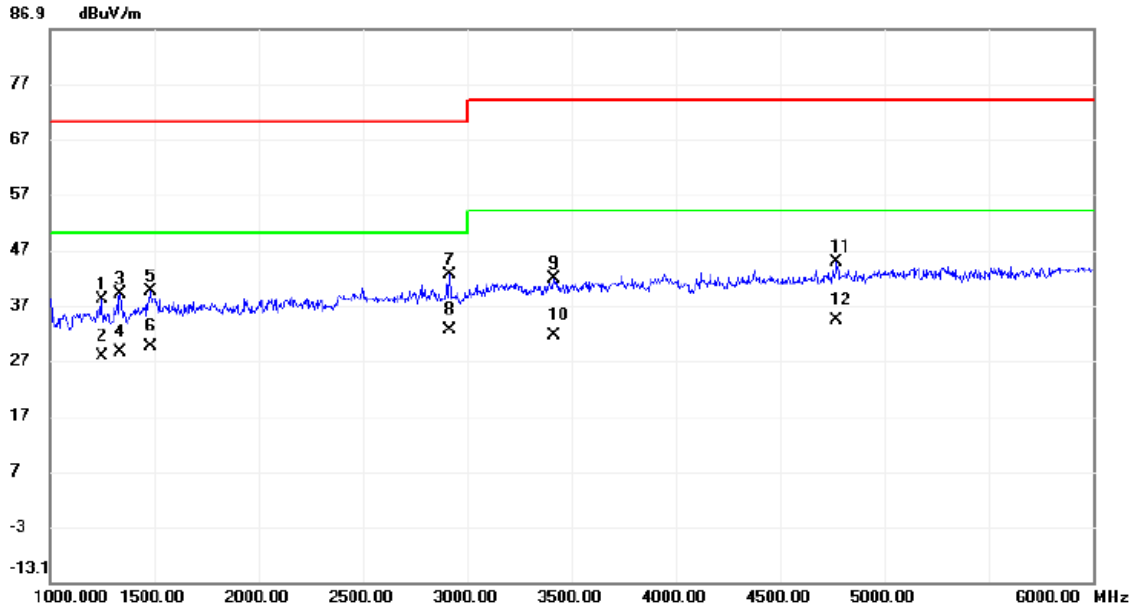

No.	Mk.	Freq. MHz	Reading Level dBuV	Correct Factor dB	Measure- ment dBuV/m	Limit dBuV/m	Margin dB	Detector	Comment
1		1247.500	43.29	-5.32	37.97	70.00	-32.03	peak	
2		1247.500	33.18	-5.32	27.86	50.00	-22.14	AVG	
3		1337.500	43.76	-4.70	39.06	70.00	-30.94	peak	
4		1337.500	33.24	-4.70	28.54	50.00	-21.46	AVG	
5		1480.000	43.23	-3.70	39.53	70.00	-30.47	peak	
6		1480.000	33.16	-3.70	29.46	50.00	-20.54	AVG	
7		2915.000	41.29	1.36	42.65	70.00	-27.35	peak	
8	*	2915.000	31.25	1.36	32.61	50.00	-17.39	AVG	
9		3415.000	38.87	2.99	41.86	74.00	-32.14	peak	
10		3415.000	28.51	2.99	31.50	54.00	-22.50	AVG	
11		4772.500	37.97	6.76	44.73	74.00	-29.27	peak	
12		4772.500	27.45	6.76	34.21	54.00	-19.79	AVG	



Test Voltage	AC 230V/50Hz	Polarization	Vertical
Test Mode	Mode 3		

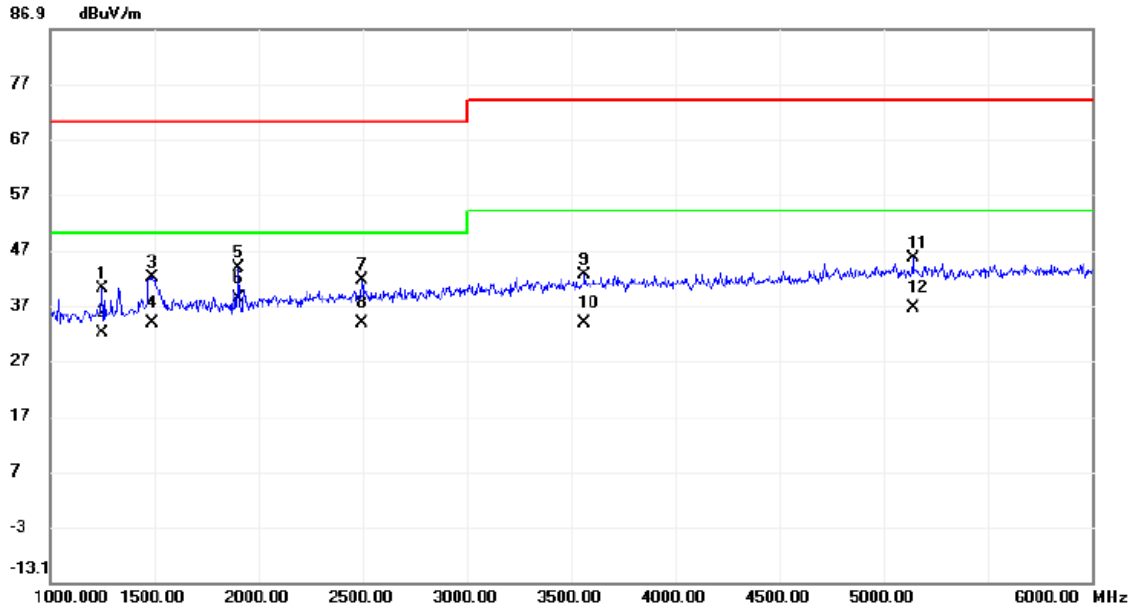

No.	Mk.	Freq. MHz	Reading Level dBuV	Correct Factor dB	Measure- ment dBuV/m	Limit dBuV/m	Margin dB	Detector	Comment
1		1250.000	45.38	-5.31	40.07	70.00	-29.93	peak	
2		1250.000	37.22	-5.31	31.91	50.00	-18.09	AVG	
3		1492.500	45.68	-3.61	42.07	70.00	-27.93	peak	
4		1492.500	37.50	-3.61	33.89	50.00	-16.11	AVG	
5		1905.000	45.84	-2.18	43.66	70.00	-26.34	peak	
6	*	1905.000	40.41	-2.18	38.23	50.00	-11.77	AVG	
7		2497.500	41.28	0.18	41.46	70.00	-28.54	peak	
8		2497.500	33.58	0.18	33.76	50.00	-16.24	AVG	
9		3565.000	39.07	3.46	42.53	74.00	-31.47	peak	
10		3565.000	30.34	3.46	33.80	54.00	-20.20	AVG	
11		5142.500	37.61	7.80	45.41	74.00	-28.59	peak	
12		5142.500	28.82	7.80	36.62	54.00	-17.38	AVG	

Test Voltage	AC 230V/50Hz	Polarization	Horizontal
Test Mode	Mode 3		

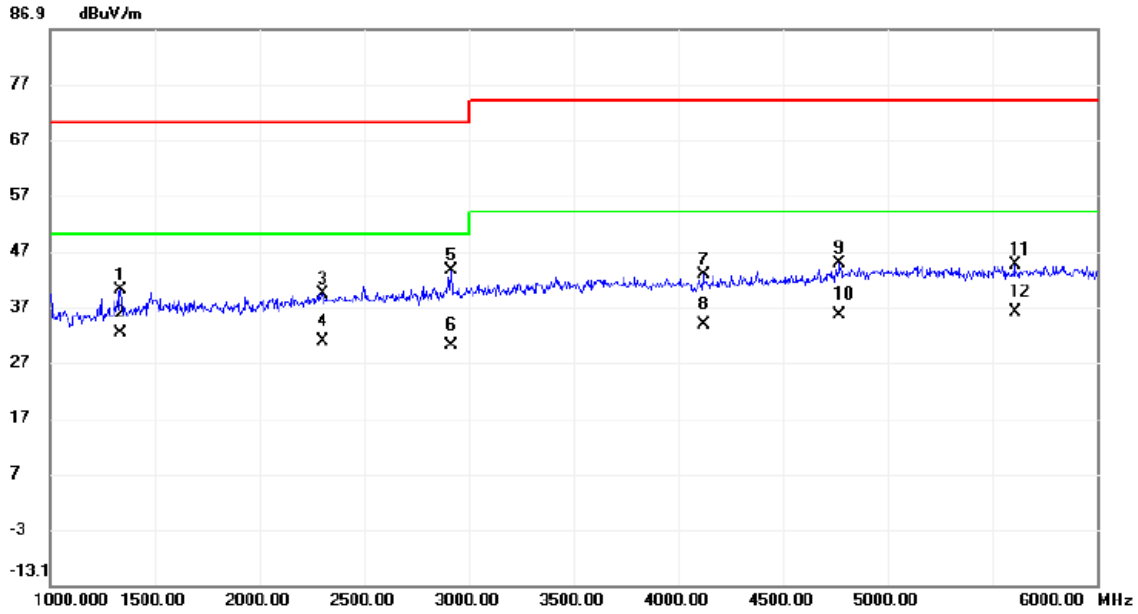

No.	Mk.	Freq. MHz	Reading Level dBuV	Correct Factor dB	Measure- ment dBuV/m	Limit dBuV/m	Margin dB	Detector	Comment
1		1337.500	44.76	-4.70	40.06	70.00	-29.94	peak	
2	*	1337.500	36.96	-4.70	32.26	50.00	-17.74	AVG	
3		2302.500	39.82	-0.61	39.21	70.00	-30.79	peak	
4		2302.500	31.33	-0.61	30.72	50.00	-19.28	AVG	
5		2915.000	42.29	1.36	43.65	70.00	-26.35	peak	
6		2915.000	28.60	1.36	29.96	50.00	-20.04	AVG	
7		4120.000	37.81	4.97	42.78	74.00	-31.22	peak	
8		4120.000	28.84	4.97	33.81	54.00	-20.19	AVG	
9		4772.500	37.97	6.76	44.73	74.00	-29.27	peak	
10		4772.500	28.81	6.76	35.57	54.00	-18.43	AVG	
11		5607.500	36.20	8.32	44.52	74.00	-29.48	peak	
12		5607.500	27.72	8.32	36.04	54.00	-17.96	AVG	

Test Voltage	AC 230V/50Hz	Polarization	Vertical
Test Mode	Mode 5		

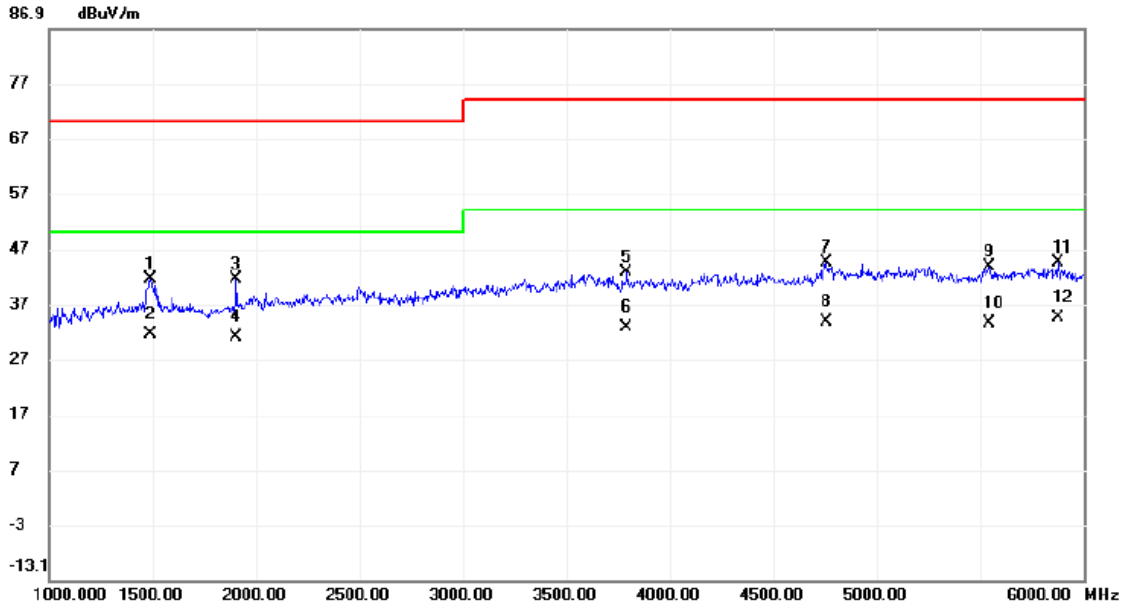

No.	Mk.	Freq. MHz	Reading Level dBuV	Correct Factor dB	Measure- ment dBuV/m	Limit dBuV/m	Margin dB	Detector	Comment
1		1490.000	45.17	-3.63	41.54	70.00	-28.46	peak	
2	*	1490.000	35.15	-3.63	31.52	50.00	-18.48	AVG	
3		1905.000	43.69	-2.18	41.51	70.00	-28.49	peak	
4		1905.000	33.26	-2.18	31.08	50.00	-18.92	AVG	
5		3790.000	38.54	4.14	42.68	74.00	-31.32	peak	
6		3790.000	28.54	4.14	32.68	54.00	-21.32	AVG	
7		4755.000	37.88	6.69	44.57	74.00	-29.43	peak	
8		4755.000	27.15	6.69	33.84	54.00	-20.16	AVG	
9		5545.000	35.59	8.22	43.81	74.00	-30.19	peak	
10		5545.000	25.40	8.22	33.62	54.00	-20.38	AVG	
11		5877.500	35.79	8.80	44.59	74.00	-29.41	peak	
12		5877.500	25.64	8.80	34.44	54.00	-19.56	AVG	

Test Voltage	AC 230V/50Hz	Polarization	Horizontal
Test Mode	Mode 5		

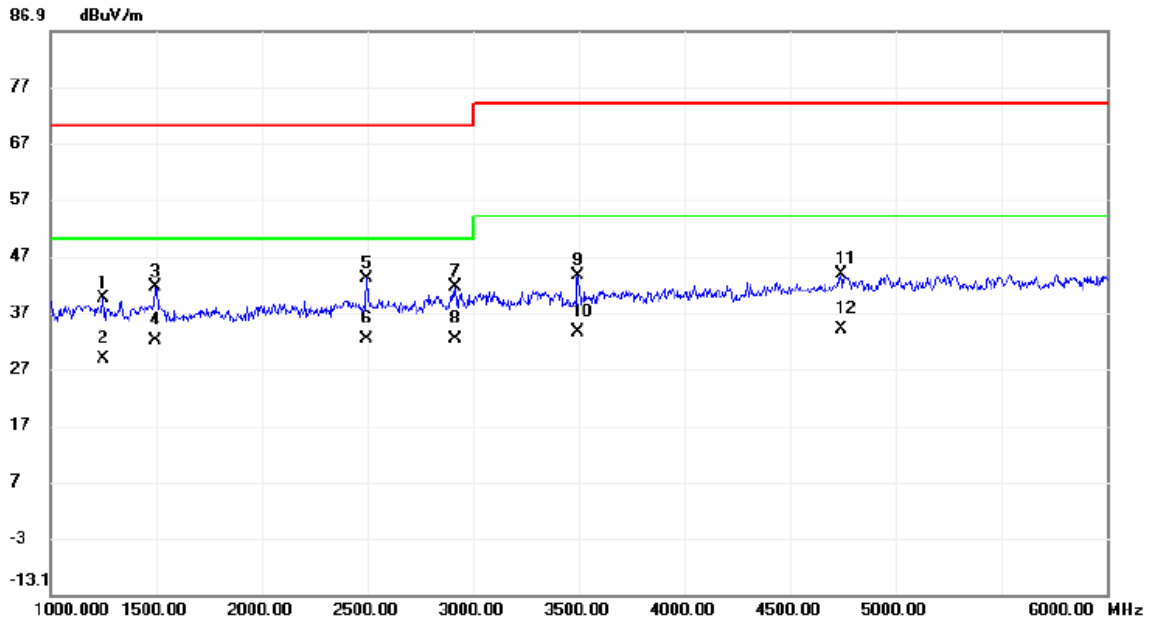

No. Mk.	Freq. MHz	Reading Level dBuV	Correct Factor dB	Measurement dBuV/m	Limit dBuV/m	Margin dB	Detector	Comment
1	1250.000	44.78	-5.31	39.47	70.00	-30.53	peak	
2	1250.000	34.18	-5.31	28.87	50.00	-21.13	AVG	
3	1497.500	45.15	-3.57	41.58	70.00	-28.42	peak	
4	1497.500	35.65	-3.57	32.08	50.00	-17.92	AVG	
5	2497.500	42.78	0.18	42.96	70.00	-27.04	peak	
6 *	2497.500	32.15	0.18	32.33	50.00	-17.67	AVG	
7	2915.000	40.25	1.36	41.61	70.00	-28.39	peak	
8	2915.000	30.97	1.36	32.33	50.00	-17.67	AVG	
9	3497.500	40.19	3.26	43.45	74.00	-30.55	peak	
10	3497.500	30.26	3.26	33.52	54.00	-20.48	AVG	
11	4742.500	37.15	6.63	43.78	74.00	-30.22	peak	
12	4742.500	27.48	6.63	34.11	54.00	-19.89	AVG	

Test Voltage	AC 110V/60Hz	Polarization	Vertical
Test Mode	Mode 3		

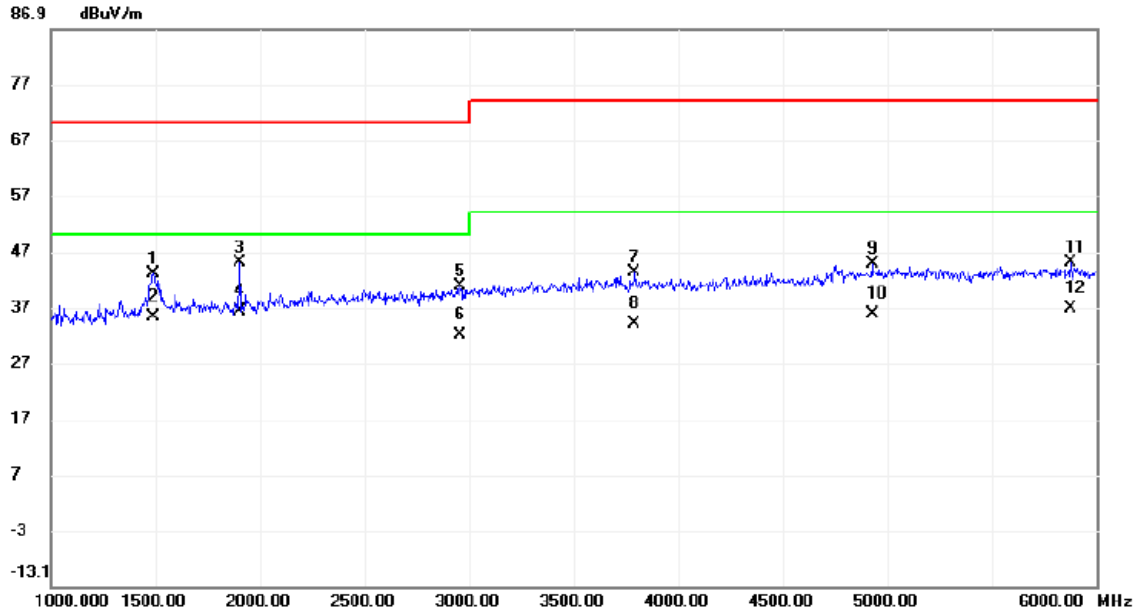

No.	Mk.	Freq. MHz	Reading Level dBuV	Correct Factor dB	Measure- ment dBuV/m	Limit dBuV/m	Margin dB	Detector	Comment
1		1490.000	46.67	-3.63	43.04	70.00	-26.96	peak	
2		1490.000	38.82	-3.63	35.19	50.00	-14.81	AVG	
3		1905.000	47.19	-2.18	45.01	70.00	-24.99	peak	
4	*	1905.000	38.42	-2.18	36.24	50.00	-13.76	AVG	
5		2957.500	39.35	1.46	40.81	70.00	-29.19	peak	
6		2957.500	30.67	1.46	32.13	50.00	-17.87	AVG	
7		3790.000	39.04	4.14	43.18	74.00	-30.82	peak	
8		3790.000	29.79	4.14	33.93	54.00	-20.07	AVG	
9		4927.500	37.35	7.37	44.72	74.00	-29.28	peak	
10		4927.500	28.37	7.37	35.74	54.00	-18.26	AVG	
11		5877.500	36.29	8.80	45.09	74.00	-28.91	peak	
12		5877.500	27.88	8.80	36.68	54.00	-17.32	AVG	

Test Voltage	AC 110V/60Hz	Polarization	Horizontal
Test Mode	Mode 3		

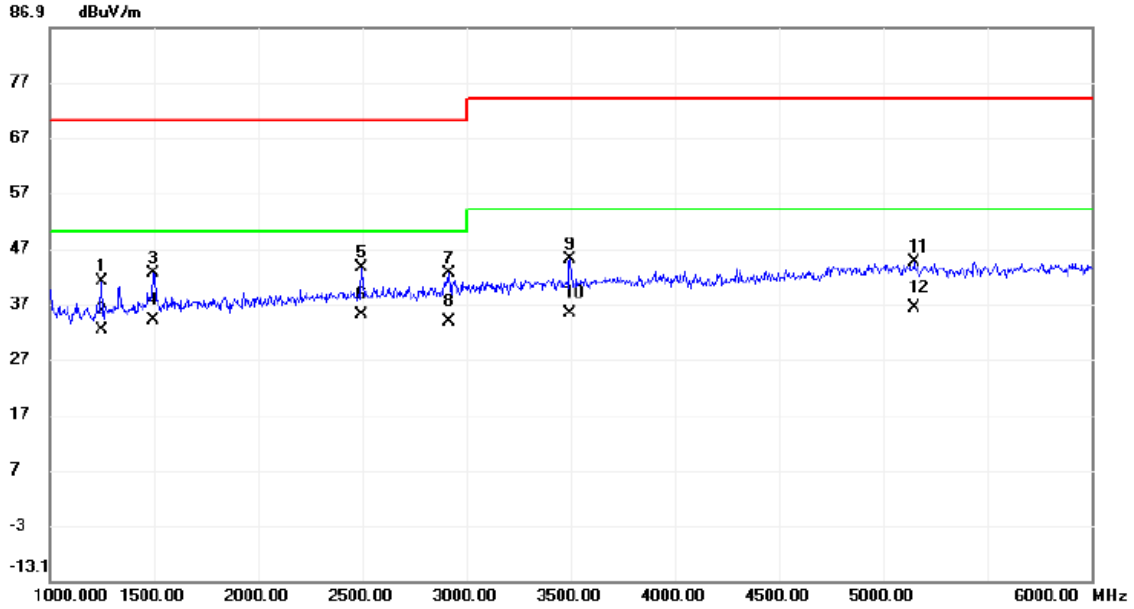

No.	Mk.	Freq. MHz	Reading Level dBuV	Correct Factor dB	Measure- ment dBuV/m	Limit dBuV/m	Margin dB	Detector	Comment
1		1250.000	46.28	-5.31	40.97	70.00	-29.03	peak	
2		1250.000	37.56	-5.31	32.25	50.00	-17.75	AVG	
3		1497.500	46.15	-3.57	42.58	70.00	-27.42	peak	
4		1497.500	37.54	-3.57	33.97	50.00	-16.03	AVG	
5		2497.500	43.28	0.18	43.46	70.00	-26.54	peak	
6	*	2497.500	34.90	0.18	35.08	50.00	-14.92	AVG	
7		2915.000	41.25	1.36	42.61	70.00	-27.39	peak	
8		2915.000	32.48	1.36	33.84	50.00	-16.16	AVG	
9		3497.500	41.69	3.26	44.95	74.00	-29.05	peak	
10		3497.500	31.98	3.26	35.24	54.00	-18.76	AVG	
11		5147.500	36.73	7.81	44.54	74.00	-29.46	peak	
12		5147.500	28.35	7.81	36.16	54.00	-17.84	AVG	

### 3.3 CONDUCTED EMISSION MEASUREMENT AT AC MAINS POWER PORTS

#### 3.3.1 LIMITS

Requirements for conducted emissions from AC mains power ports of Class B equipment

Frequency Range MHz	Coupling Device	Detector Type / bandwidth	Class B Limits (dB( $\mu$ V) )
0.15 - 0.5	AMN	Quasi Peak / 9 kHz	66-56
0.5 - 5			56
5 - 30			60
0.15 - 0.5	AMN	Average / 9 kHz	56-46
0.5 - 5			46
5 - 30			50

NOTE:

(1) The test result calculated as following:

Measurement Value = Reading Level + Correct Factor

Correct Factor = Insertion Loss + Cable Loss + Attenuator Factor(if use)

Margin Level = Measurement Value – Limit Value

#### 3.3.2 MEASUREMENT INSTRUMENTS LIST

Item	Kind of Equipment	Manufacturer	Type No.	Series Model	Calibrated until
1	50 $\Omega$ Terminator	SHX	TF2-3G-A	8122901	Feb. 28, 2021
2	TWO-LINE V-NETWORK	R&S	ENV216	100526	Mar. 01, 2021
3	EMI Test Receiver	R&S	ESR3	101862	Aug. 03, 2020
4	Artificial-Mains Network	SCHWARZBECK	NSLK 8127	8127685	Mar. 01, 2021
5	TRANSIENT LIMITER	EM	EM-7600	772	Mar. 01, 2021
6	Cable	N/A	RG400	N/A(12m)	Mar. 10, 2021
7	Measurement Software	Farad	EZ-EMC Ver.NB-03A1 -01	N/A	N/A

Remark: "N/A" denotes no model name, serial no. or calibration specified.

All calibration period of equipment list is one year.

#### 3.3.3 TEST PROCEDURE

- The EUT was placed 0.8 meters from the horizontal ground plane with EUT being connected to the power mains through a line impedance stabilization network (LISN). All other support equipments powered from additional LISN(s). The LISN provide 50 Ohm/ 50uH of coupling impedance for the measuring instrument.
- Interconnecting cables that hang closer than 40 cm to the ground plane shall be folded back and forth in the center forming a bundle 30 to 40 cm long.
- I/O cables that are not connected to a peripheral shall be bundled in the center. The end of the cable may be terminated, if required, using the correct terminating impedance. The overall length shall not exceed 1 m.
- LISN at least 80 cm from nearest part of EUT chassis.
- For the actual test configuration, please refer to the related Item –EUT Test Photos.

#### 3.3.4 DEVIATION FROM TEST STANDARD

No deviation

### 3.3.5 TEST SETUP

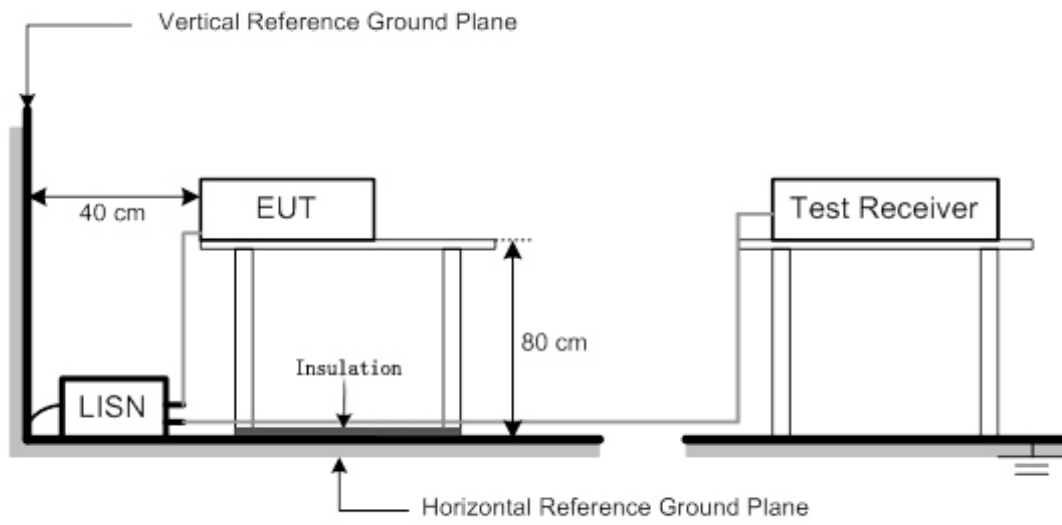



### 3.3.6 TEST RESULTS

Test Voltage	AC 230V/50Hz	Phase	Line
Test Mode	Mode 1		

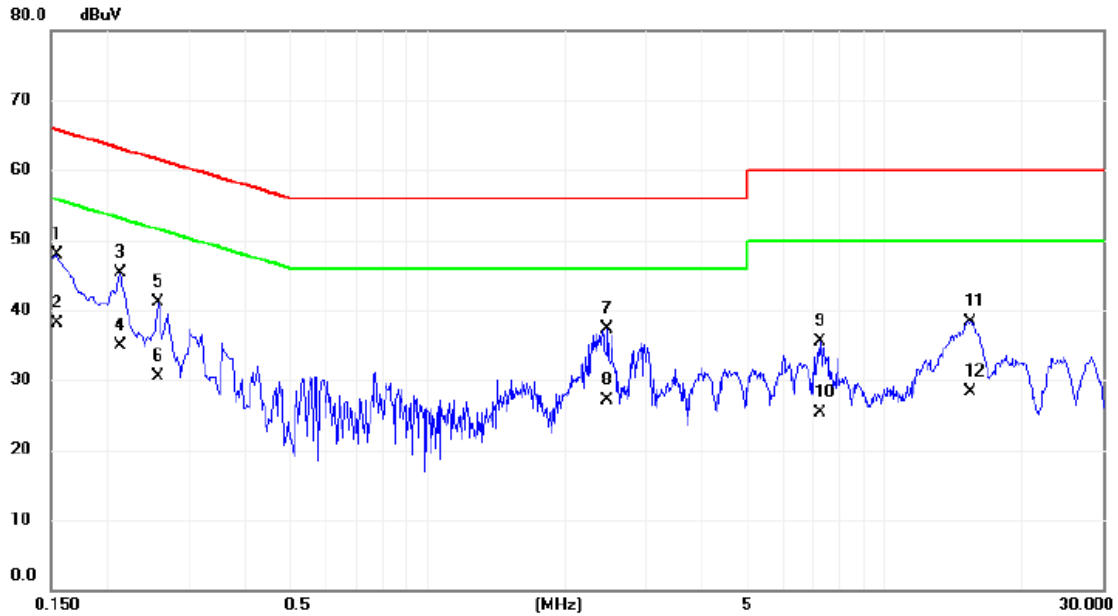

No.	Mk.	Freq. MHz	Reading Level dBuV	Correct Factor dB	Measure- ment dBuV	Limit dBuV	Margin dB	Detector	Comment
1		0.1544	37.42	10.49	47.91	65.76	-17.85	QP	
2	*	0.1544	27.60	10.49	38.09	55.76	-17.67	AVG	
3		0.2130	34.74	10.47	45.21	63.09	-17.88	QP	
4		0.2130	24.50	10.47	34.97	53.09	-18.12	AVG	
5		0.2580	30.56	10.47	41.03	61.50	-20.47	QP	
6		0.2580	20.10	10.47	30.57	51.50	-20.93	AVG	
7		2.4765	26.56	10.66	37.22	56.00	-18.78	QP	
8		2.4765	16.50	10.66	27.16	46.00	-18.84	AVG	
9		7.2420	24.63	10.86	35.49	60.00	-24.51	QP	
10		7.2420	14.50	10.86	25.36	50.00	-24.64	AVG	
11		15.3643	27.34	10.99	38.33	60.00	-21.67	QP	
12		15.3643	17.40	10.99	28.39	50.00	-21.61	AVG	

Test Voltage	AC 230V/50Hz	Phase	Neutral
Test Mode	Mode 1		

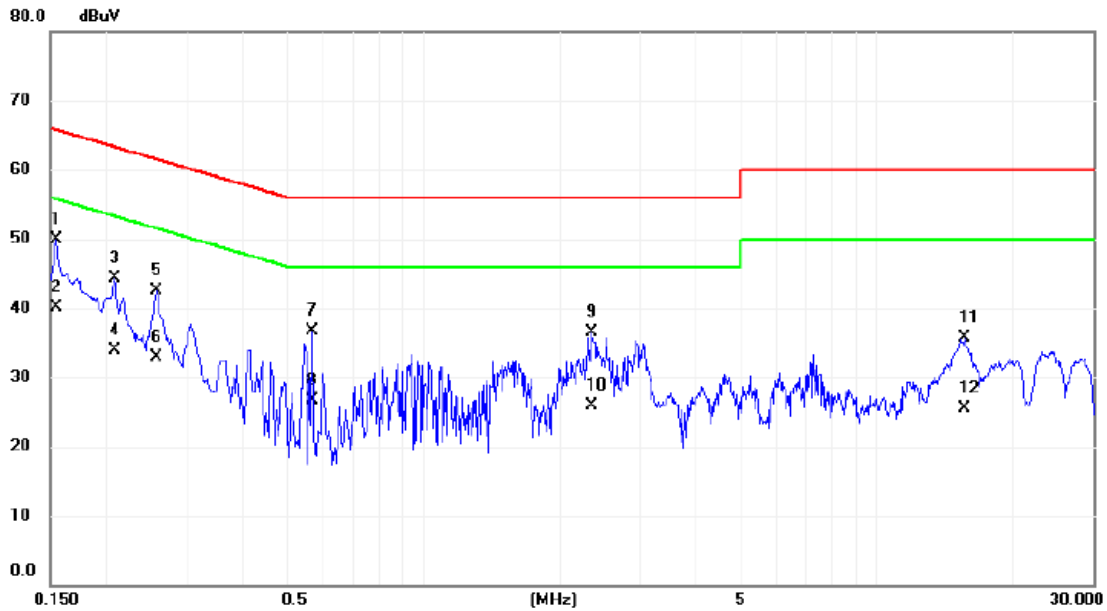

No.	Mk.	Freq. MHz	Reading Level dBuV	Correct Factor dB	Measure- ment dBuV	Limit dBuV	Margin dB	Detector	Comment
1		0.1544	39.38	10.43	49.81	65.76	-15.95	QP	
2	*	0.1544	29.70	10.43	40.13	55.76	-15.63	AVG	
3		0.2084	33.92	10.45	44.37	63.27	-18.90	QP	
4		0.2084	23.50	10.45	33.95	53.27	-19.32	AVG	
5		0.2580	32.04	10.47	42.51	61.50	-18.99	QP	
6		0.2580	22.40	10.47	32.87	51.50	-18.63	AVG	
7		0.5684	26.12	10.49	36.61	56.00	-19.39	QP	
8		0.5684	16.30	10.49	26.79	46.00	-19.21	AVG	
9		2.3550	25.92	10.62	36.54	56.00	-19.46	QP	
10		2.3550	15.20	10.62	25.82	46.00	-20.18	AVG	
11		15.5670	24.73	10.99	35.72	60.00	-24.28	QP	
12		15.5670	14.50	10.99	25.49	50.00	-24.51	AVG	

Test Voltage	AC 230V/50Hz	Phase	Line
Test Mode	Mode 3		

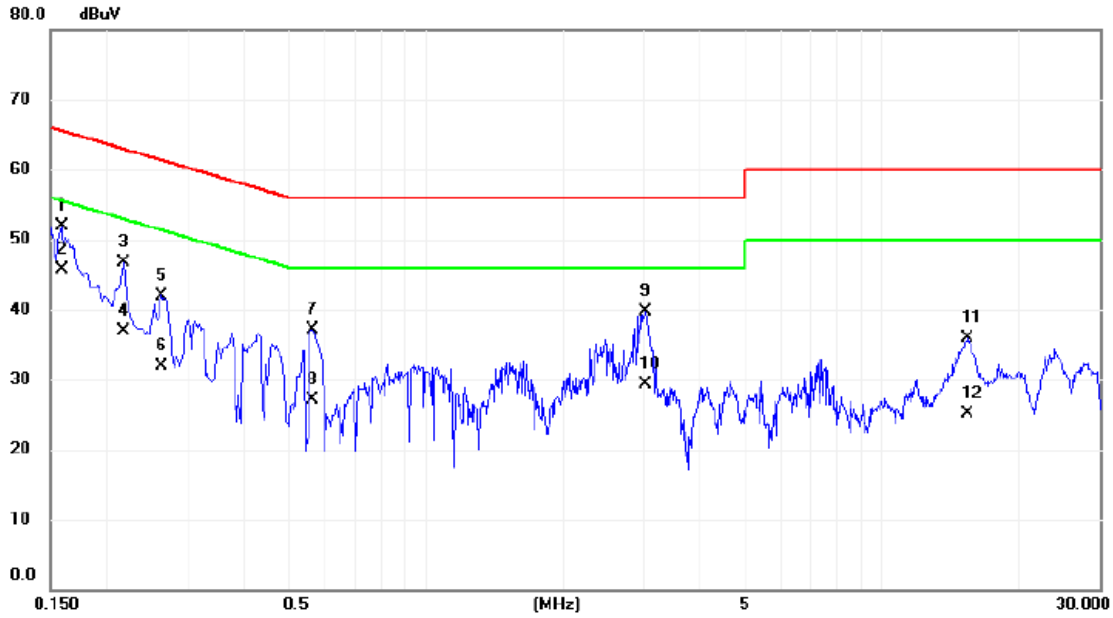

No. Mk.	Freq. MHz	Reading Level dBuV	Correct Factor dB	Measurement dBuV	Limit dBuV	Margin dB	Detector	Comment
1	0.1590	41.35	10.48	51.83	65.52	-13.69	QP	
2 *	0.1590	35.18	10.48	45.66	55.52	-9.86	AVG	
3	0.2174	36.23	10.47	46.70	62.92	-16.22	QP	
4	0.2174	26.50	10.47	36.97	52.92	-15.95	AVG	
5	0.2630	31.52	10.48	42.00	61.34	-19.34	QP	
6	0.2630	21.40	10.48	31.88	51.34	-19.46	AVG	
7	0.5640	26.65	10.52	37.17	56.00	-18.83	QP	
8	0.5640	16.50	10.52	27.02	46.00	-18.98	AVG	
9	3.0390	28.93	10.69	39.62	56.00	-16.38	QP	
10	3.0390	18.70	10.69	29.39	46.00	-16.61	AVG	
11	15.4092	24.99	10.99	35.98	60.00	-24.02	QP	
12	15.4092	14.20	10.99	25.19	50.00	-24.81	AVG	

Test Voltage	AC 230V/50Hz	Phase	Neutral
Test Mode	Mode 3		

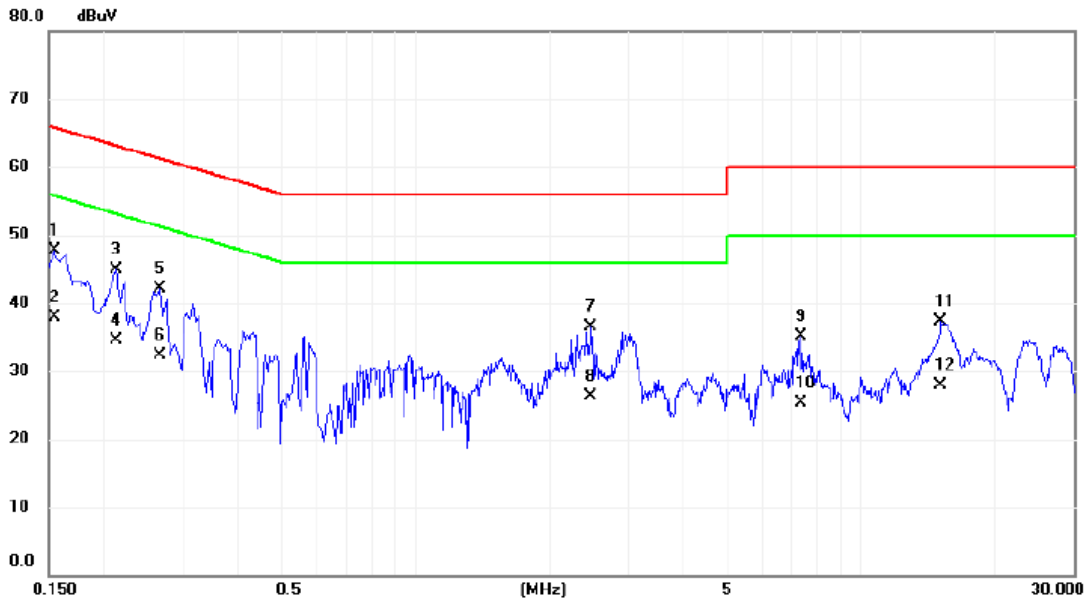

No.	Mk.	Freq. MHz	Reading Level dBuV	Correct Factor dB	Measure- ment dBuV	Limit dBuV	Margin dB	Detector	Comment
1		0.1544	37.24	10.43	47.67	65.76	-18.09	QP	
2	*	0.1544	27.50	10.43	37.93	55.76	-17.83	AVG	
3		0.2130	34.50	10.45	44.95	63.09	-18.14	QP	
4		0.2130	24.10	10.45	34.55	53.09	-18.54	AVG	
5		0.2670	31.73	10.46	42.19	61.21	-19.02	QP	
6		0.2670	21.80	10.46	32.26	51.21	-18.95	AVG	
7		2.4765	25.85	10.63	36.48	56.00	-19.52	QP	
8		2.4765	15.60	10.63	26.23	46.00	-19.77	AVG	
9		7.3140	24.21	10.81	35.02	60.00	-24.98	QP	
10		7.3140	14.50	10.81	25.31	50.00	-24.69	AVG	
11		15.0900	26.33	10.99	37.32	60.00	-22.68	QP	
12		15.0900	16.90	10.99	27.89	50.00	-22.11	AVG	

Test Voltage	AC 230V/50Hz	Phase	Line
Test Mode	Mode 5		

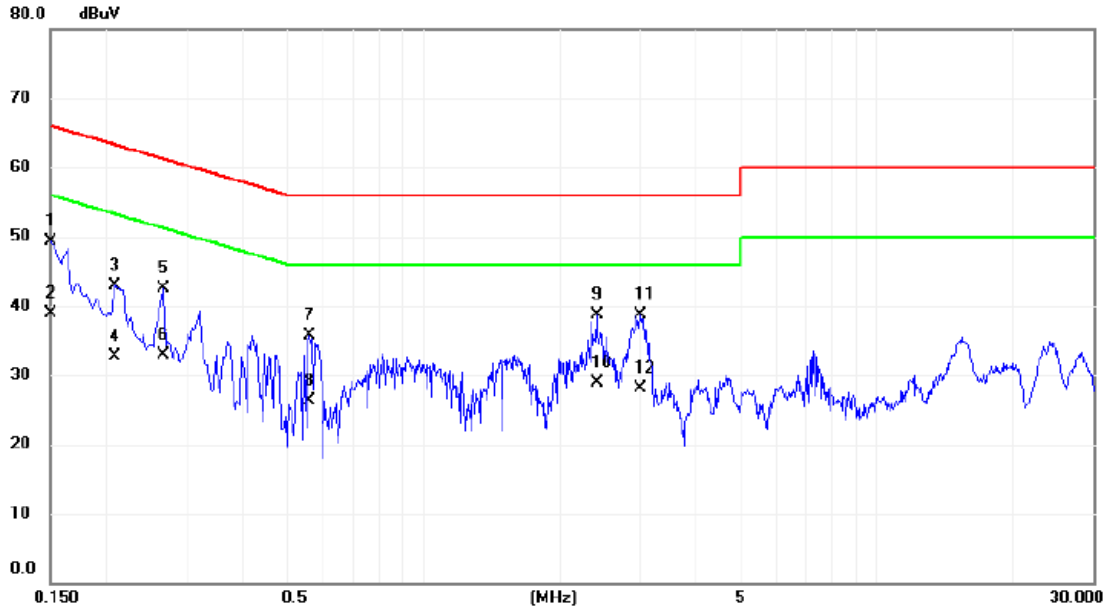

No.	Mk.	Freq. MHz	Reading Level dBuV	Correct Factor dB	Measure- ment dBuV	Limit dBuV	Margin dB	Detector	Comment
1	*	0.1500	38.78	10.49	49.27	66.00	-16.73	QP	
2		0.1500	28.50	10.49	38.99	56.00	-17.01	AVG	
3		0.2084	32.51	10.48	42.99	63.27	-20.28	QP	
4		0.2084	22.30	10.48	32.78	53.27	-20.49	AVG	
5		0.2670	32.04	10.48	42.52	61.21	-18.69	QP	
6		0.2670	22.40	10.48	32.88	51.21	-18.33	AVG	
7		0.5594	25.13	10.52	35.65	56.00	-20.35	QP	
8		0.5594	15.70	10.52	26.22	46.00	-19.78	AVG	
9		2.4180	28.04	10.66	38.70	56.00	-17.30	QP	
10		2.4180	18.30	10.66	28.96	46.00	-17.04	AVG	
11		3.0120	27.97	10.69	38.66	56.00	-17.34	QP	
12		3.0120	17.50	10.69	28.19	46.00	-17.81	AVG	

Test Voltage	AC 230V/50Hz	Phase	Neutral
Test Mode	Mode 5		

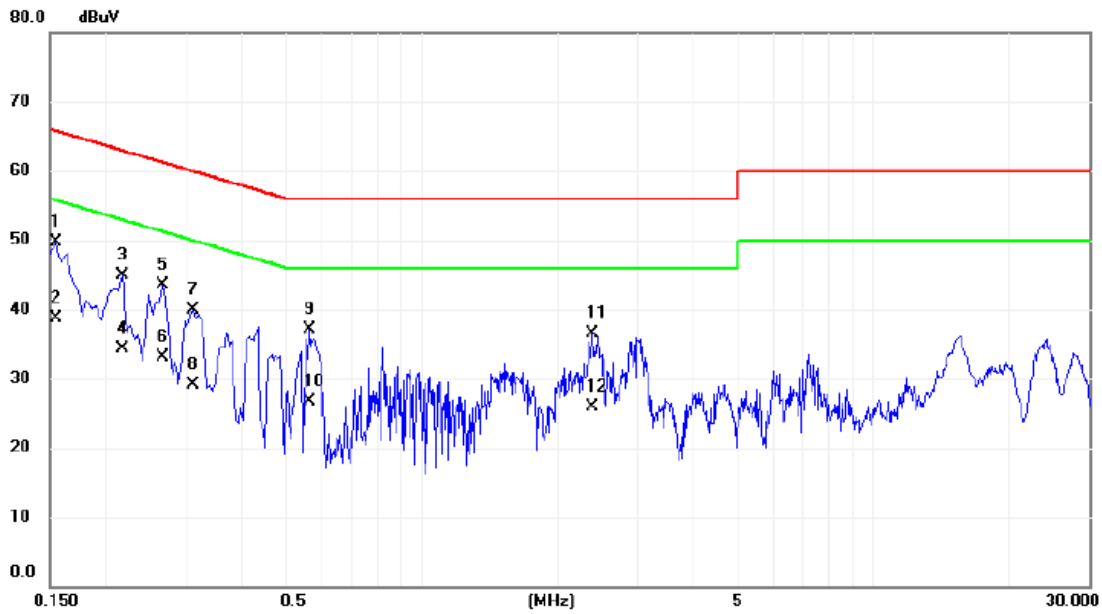

No.	Mk.	Freq. MHz	Reading Level dBuV	Correct Factor dB	Measure- ment dBuV	Limit dBuV	Margin dB	Detector	Comment
1	*	0.1544	39.25	10.43	49.68	65.76	-16.08	QP	
2		0.1544	28.36	10.43	38.79	55.76	-16.97	AVG	
3		0.2174	34.36	10.45	44.81	62.92	-18.11	QP	
4		0.2174	23.85	10.45	34.30	52.92	-18.62	AVG	
5		0.2670	32.96	10.46	43.42	61.21	-17.79	QP	
6		0.2670	22.65	10.46	33.11	51.21	-18.10	AVG	
7		0.3120	29.45	10.45	39.90	59.92	-20.02	QP	
8		0.3120	18.74	10.45	29.19	49.92	-20.73	AVG	
9		0.5640	26.61	10.49	37.10	56.00	-18.90	QP	
10		0.5640	16.21	10.49	26.70	46.00	-19.30	AVG	
11		2.3774	25.94	10.63	36.57	56.00	-19.43	QP	
12		2.3774	15.36	10.63	25.99	46.00	-20.01	AVG	

Test Voltage	AC 110V/60Hz	Phase	Line
Test Mode	Mode 3		

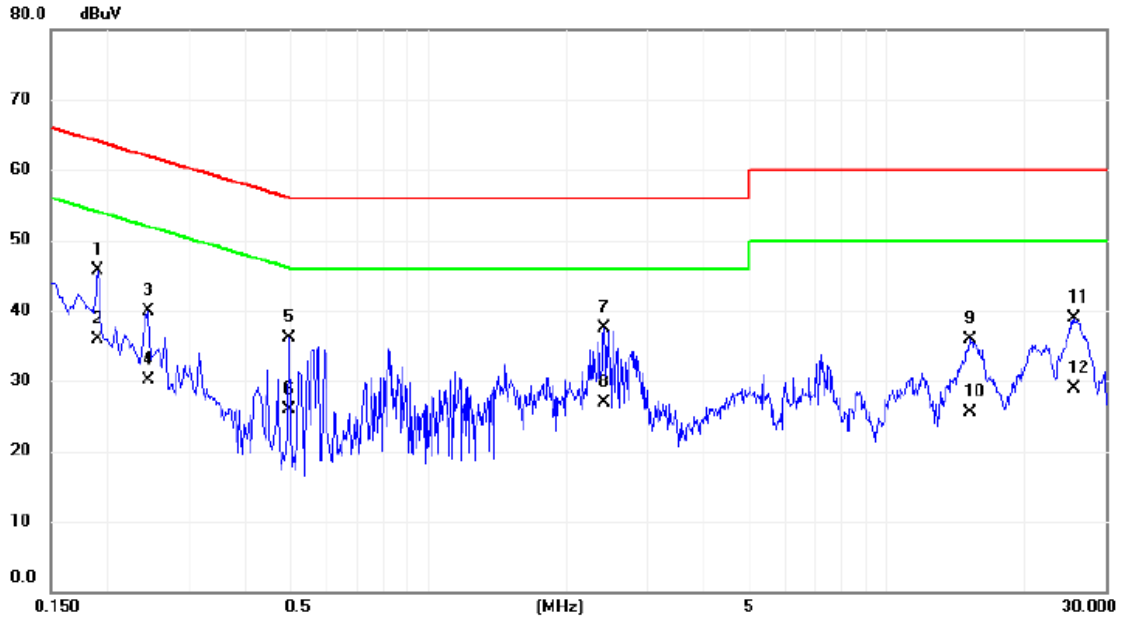

No.	Mk.	Freq. MHz	Reading Level dBuV	Correct Factor dB	Measure- ment dBuV	Limit dBuV	Margin dB	Detector	Comment
1		0.1905	35.23	10.48	45.71	64.01	-18.30	QP	
2	*	0.1905	25.40	10.48	35.88	54.01	-18.13	AVG	
3		0.2444	29.51	10.47	39.98	61.95	-21.97	QP	
4		0.2444	19.70	10.47	30.17	51.95	-21.78	AVG	
5		0.4964	25.65	10.50	36.15	56.06	-19.91	QP	
6		0.4964	15.40	10.50	25.90	46.06	-20.16	AVG	
7		2.4090	26.76	10.66	37.42	56.00	-18.58	QP	
8		2.4090	16.20	10.66	26.86	46.00	-19.14	AVG	
9		15.1575	24.84	10.99	35.83	60.00	-24.17	QP	
10		15.1575	14.50	10.99	25.49	50.00	-24.51	AVG	
11		25.5120	27.93	11.01	38.94	60.00	-21.06	QP	
12		25.5120	17.80	11.01	28.81	50.00	-21.19	AVG	

Test Voltage	AC 110V/60Hz	Phase	Neutral
Test Mode	Mode 3		

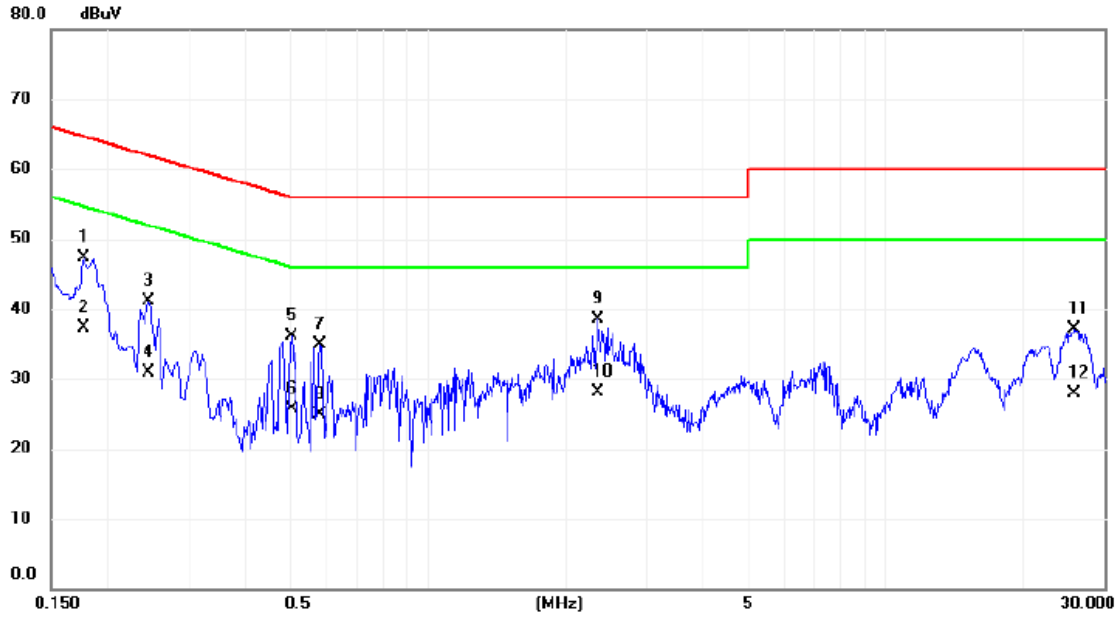

No.	Mk.	Freq. MHz	Reading Level dBuV	Correct Factor dB	Measure- ment dBuV	Limit dBuV	Margin dB	Detector	Comment
1	*	0.1770	36.86	10.44	47.30	64.63	-17.33	QP	
2		0.1770	26.80	10.44	37.24	54.63	-17.39	AVG	
3		0.2444	30.73	10.47	41.20	61.95	-20.75	QP	
4		0.2444	20.50	10.47	30.97	51.95	-20.98	AVG	
5		0.5052	25.61	10.49	36.10	56.00	-19.90	QP	
6		0.5052	15.30	10.49	25.79	46.00	-20.21	AVG	
7		0.5820	24.45	10.49	34.94	56.00	-21.06	QP	
8		0.5820	14.50	10.49	24.99	46.00	-21.01	AVG	
9		2.3460	27.88	10.62	38.50	56.00	-17.50	QP	
10		2.3460	17.50	10.62	28.12	46.00	-17.88	AVG	
11		25.7955	26.13	11.00	37.13	60.00	-22.87	QP	
12		25.7955	16.90	11.00	27.90	50.00	-22.10	AVG	



#### 4. EMC EMISSION TEST- EN 55032:2015+AC:2016

##### 4.1 RADIATED EMISSIONS UP TO 1 GHZ

##### 4.1.1 LIMITS

Class B equipment up to 1000MHz

Frequency Range MHz	Measurement			Class B limits dB(μV/m)
	Facility	Distance m	Detector type/ bandwidth	
30 - 230	SAC	10	Quasi peak / 120 kHz	30
230 - 1000				37

Notes:

- (1) The limit for radiated test was performed according to as following: EN 55032
- (2) The tighter limit applies at the band edges.
- (3) Emission level (dBuV/m)=20log Emission level (uV/m).
- (4) The test result calculated as following:  
 Measurement Value = Reading Level + Correct Factor  
 Correct Factor = Antenna Factor + Cable Loss - Amplifier Gain(if use)  
 Margin Level = Measurement Value - Limit Value

##### 4.1.2 MEASUREMENT INSTRUMENTS LIST

Item	Kind of Equipment	Manufacturer	Type No.	Series Model	Calibrated until
1	Receiver	Keysight	N9038A	MY54450004	Aug. 03, 2020
2	MXE EMI Receiver	Agilent	N9038A	MY53220133	Feb. 28, 2021
3	Pre-Amplifier	EMC INSTRUMENT	EMC 9135	980284	Mar. 01, 2021
4	Pre-Amplifier	EMC INSTRUMENT	EMC 9135	980283	Mar. 01, 2021
5	Trilog-Broadband Antenna	Schwarzbeck	VULB9168	946	Oct. 26, 2020
6	Trilog-Broadband Antenna	Schwarzbeck	VULB9168	947	Dec. 02, 2020
7	Cable	emci	LMR-400(5m+11 m+15m)	N/A	Nov. 22, 2020
8	Cable	emci	LMR-400(5m+8m +8m)	N/A	Nov. 22, 2020
9	Measurement Software	Farad	EZ-EMC Ver.BTL-2ANT-1	N/A	N/A
10	Multi-Device Controller	ETS-Lindgren	2090	N/A	N/A
11	Attenuator	EMCI	EMCI-N-6-06	N0670	Dec. 02, 2020
12	Attenuator	EMCI	EMCI-N-6-06	N0671	Oct. 26, 2020

Remark: "N/A" denotes no model no., no serial no. or no calibration specified.

All calibration period of equipment list is one year.

#### 4.1.3 TEST PROCEDURE

- The measuring distance of 10 m shall be used for measurements. The EUT was placed on the top of a rotating table 0.8 meter above the ground at a 10 meter semi-anechoic chamber. The table was rotated 360 degrees to determine the position of the highest radiation.(below 1GHz).
- The height of the equipment or of the substitution antenna shall be 0.8 m, the height of the test antenna shall vary between 1 m to 4 m. Both horizontal and vertical polarizations of the antenna are set to make the measurement.
- The initial step in collecting radiated emission data is a receiver peak detector mode pre-scanning the measurement frequency range. Significant peaks are then marked and then Quasi Peak detector mode re-measured.
- All readings are Peak unless otherwise stated QP in column of Note. Peak denotes that the Peak reading compliance with the QP Limits and then QP Mode measurement didn't perform.  
(below 1GHz)
- For the actual test configuration, please refer to the related Item - Block Diagram of system tested.

#### 4.1.4 DEVIATION FROM TEST STANDARD

No deviation

#### 4.1.5 TEST SETUP

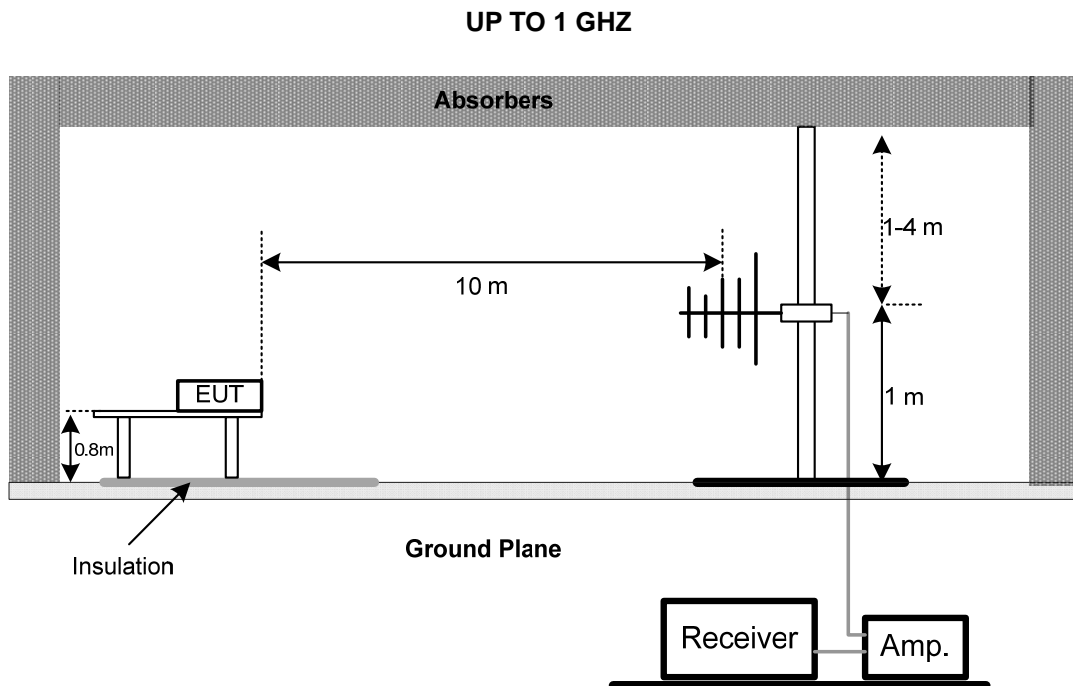

Note: The antenna can be moved between 1 to 4 meters above the ground.

## 4.1.6 MEASUREMENT DISTANCE

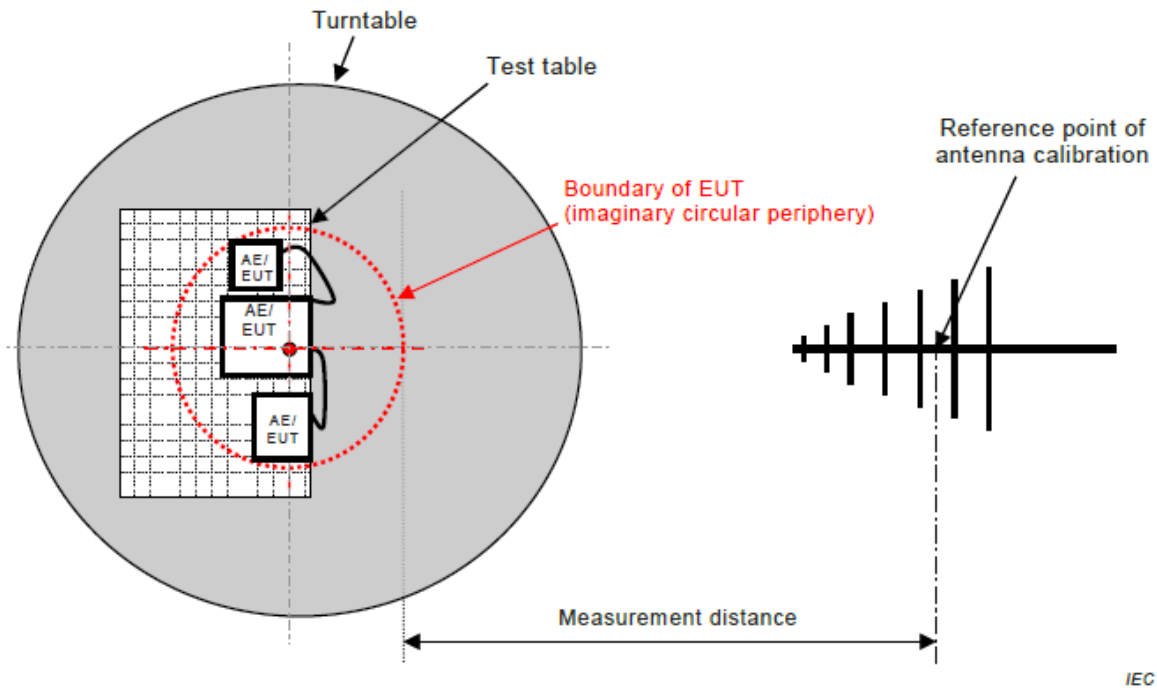

Figure C.1 – Measurement distance

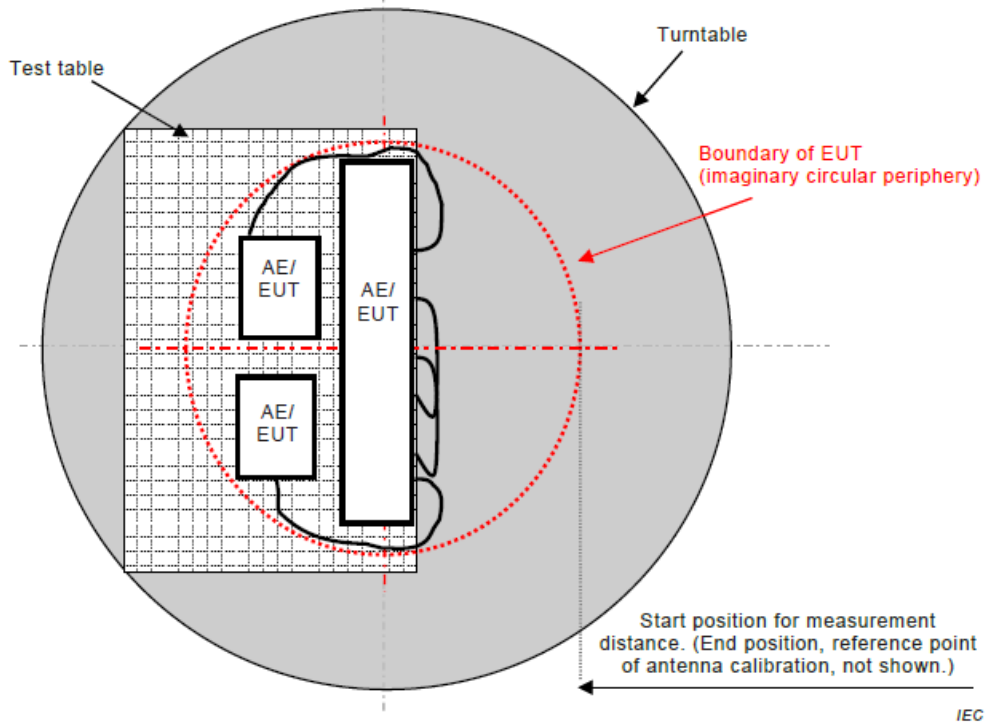
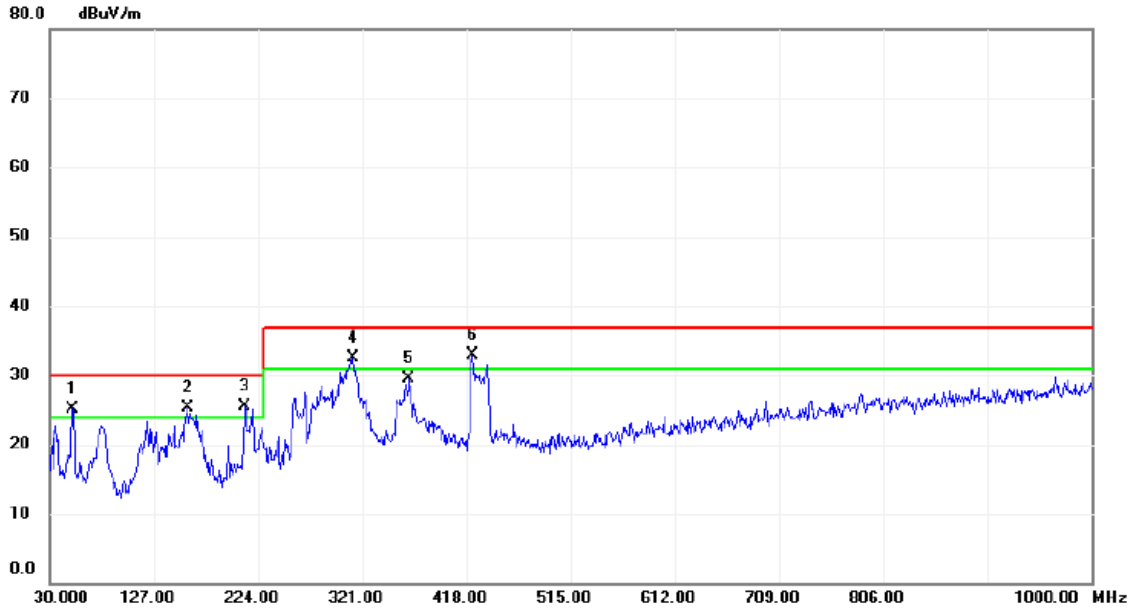

Figure C.2 – Boundary of EUT, Local AE and associated cabling

### 4.1.7 TEST RESULTS (UP TO 1 GHZ)

Test Voltage	AC 230V/50Hz	Polarization	Vertical
Test Mode	Mode 3		



No.	Mk.	Freq. MHz	Reading Level dBuV	Correct Factor dB	Measure- ment dBuV/m	Limit dBuV/m	Margin dB	Detector	Comment
1	!	51.3400	41.92	-16.72	25.20	30.00	-4.80	QP	
2	!	159.0100	40.91	-15.66	25.25	30.00	-4.75	QP	
3	!	211.3900	44.09	-18.65	25.44	30.00	-4.56	QP	
4	!	312.2700	46.98	-14.38	32.60	37.00	-4.40	QP	
5		364.6500	42.76	-13.25	29.51	37.00	-7.49	QP	
6	*	423.8200	44.71	-11.81	32.90	37.00	-4.10	QP	

Test Voltage	AC 230V/50Hz	Polarization	Horizontal
Test Mode	Mode 3		

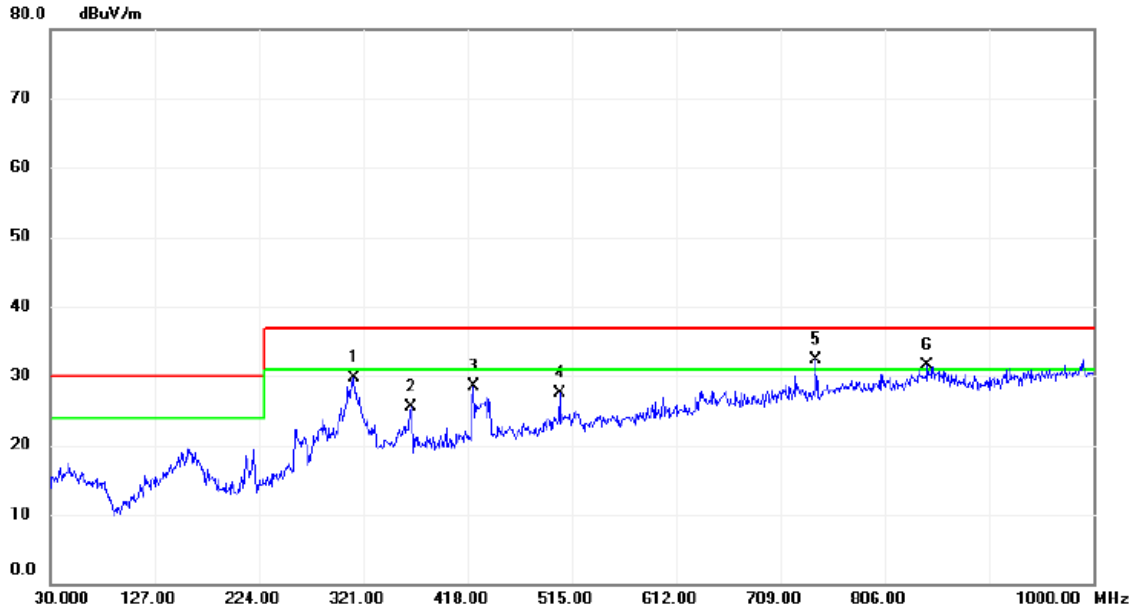

No.	Mk.	Freq. MHz	Reading Level dBuV	Correct Factor dB	Measure- ment dBuV/m	Limit dBuV/m	Margin dB	Detector	Comment
1		312.2700	43.73	-14.11	29.62	37.00	-7.38	QP	
2		365.6200	38.31	-12.90	25.41	37.00	-11.59	QP	
3		423.8200	39.98	-11.39	28.59	37.00	-8.41	QP	
4		503.3600	37.05	-9.64	27.41	37.00	-9.59	QP	
5	*	741.9800	37.33	-5.04	32.29	37.00	-4.71	QP	
6	!	845.7700	35.25	-3.83	31.42	37.00	-5.58	QP	

## 4.2 RADIATED EMISSIONS ABOVE 1 GHZ

### 4.2.1 LIMITS

Class B equipment above 1000MHz

Frequency Range MHz	Measurement			Class B limits dB( $\mu$ V/m)
	Facility	Distance m	Detector type/bandwidth	
1000 - 3000	FSOATS	3	Average / 1 MHz	50
3000 - 6000				54
1000 - 3000			Peak / 1 MHz	70
3000 - 6000				74

Notes:

- (1) The limit for radiated test was performed according to as following: EN 55032
- (2) The tighter limit applies at the band edges.
- (3) Emission level (dB $\mu$ V/m)=20log Emission level (uV/m).
- (4) The test result calculated as following:  
 Measurement Value = Reading Level + Correct Factor  
 Correct Factor = Antenna Factor + Cable Loss - Amplifier Gain(if use)  
 Margin Level = Measurement Value - Limit Value

Required highest frequency for radiated measurement

Highest internal frequency ( $F_x$ ) MHz	Highest measured frequency MHz
$F_x \leq 108$	1000
$108 < F_x \leq 500$	2000
$500 < F_x \leq 1000$	5000
$F_x > 1000$	5 <sup>th</sup> up to a maximum 6 GHz,

Note for FM and TV broadcast receiver,  $F_x$  is determined from the highest frequency generated or used excluding the local oscillator and tuned frequencies.

Item	Kind of Equipment	Manufacturer	Type No.	Series Model	Calibrated until
1	Double Ridged Guide Antenna	ETS	3115	75846	Mar. 19, 2021
2	Amplifier	Agilent	8449B	3008A02333	Mar. 01, 2021
3	MXE EMI Receiver	Agilent	N9038A	MY53220133	Feb. 28, 2021
4	Measurement Software	Farad	EZ-EMC Ver.BTL-2ANT-1	N/A	N/A
5	Multi-Device Controller	ETS-Lindgren	2090	N/A	N/A
6	Controller	MF	MF-7802	MF780208159	N/A
7	Cable	Micable Inc.	B10-01-01-5M	18047123	Feb. 28, 2021
8	Cable	Micable Inc.	B10-01-01-12 M	18072743	Feb. 28, 2021
9	Cable	RegalWay	RWLPS50-7.9 A-SMSM-1M	20200102 001	Feb. 28, 2021

Remark: "N/A" denotes no model no., no serial no. or no calibration specified.

All calibration period of equipment list is one year.

#### 4.2.2 TEST PROCEDURE

- The measuring distance of 3 m shall be used for measurements. The EUT was placed on the top of a rotating table 0.8 meter above the ground at a 10 meter semi-anechoic chamber. The table was rotated 360 degrees to determine the position of the highest radiation.
- The height of the equipment or of the substitution antenna shall be 0.8 m, the height of the test antenna shall vary between 1 m to 4 m. Both horizontal and vertical polarizations of the antenna are set to make the measurement.
- The initial step in collecting radiated emission data is a receiver peak detector mode pre-scanning the measurement frequency range. Significant peaks are then marked and then Quasi Peak detector mode re-measured.
- All readings are Peak Mode value unless otherwise stated AVG in column of Note. If the Peak Mode Measured value compliance with the Peak Limits and lower than AVG Limits, the EUT shall be deemed to meet both Peak & AVG Limits and then only Peak Mode was measured, but AVG Mode didn't perform. (above 1GHz)
- For the actual test configuration, please refer to the related Item - Block Diagram of system tested.

#### 4.2.3 DEVIATION FROM TEST STANDARD

No deviation

#### 4.2.4 TEST SETUP

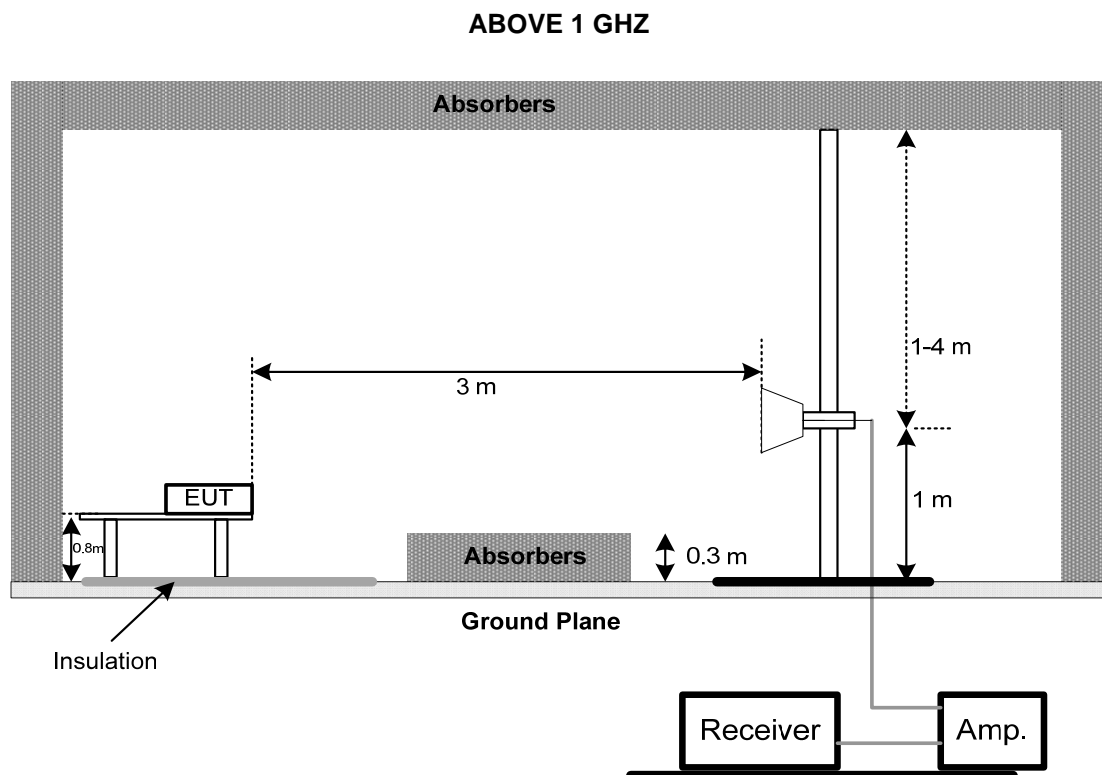

**4.2.5 MEASUREMENT DISTANCE**

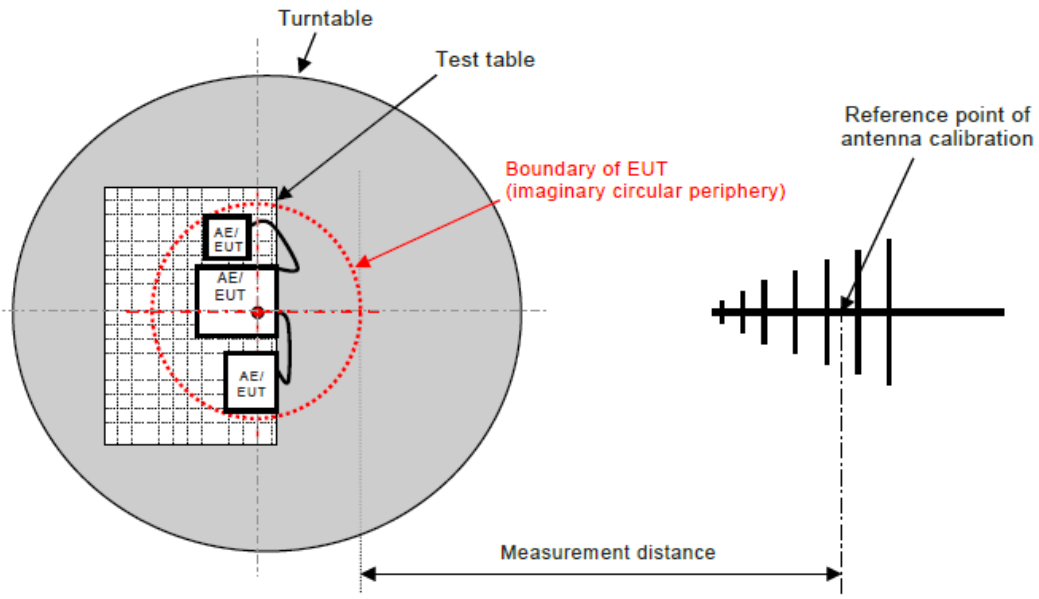

**Figure C.1 – Measurement distance**

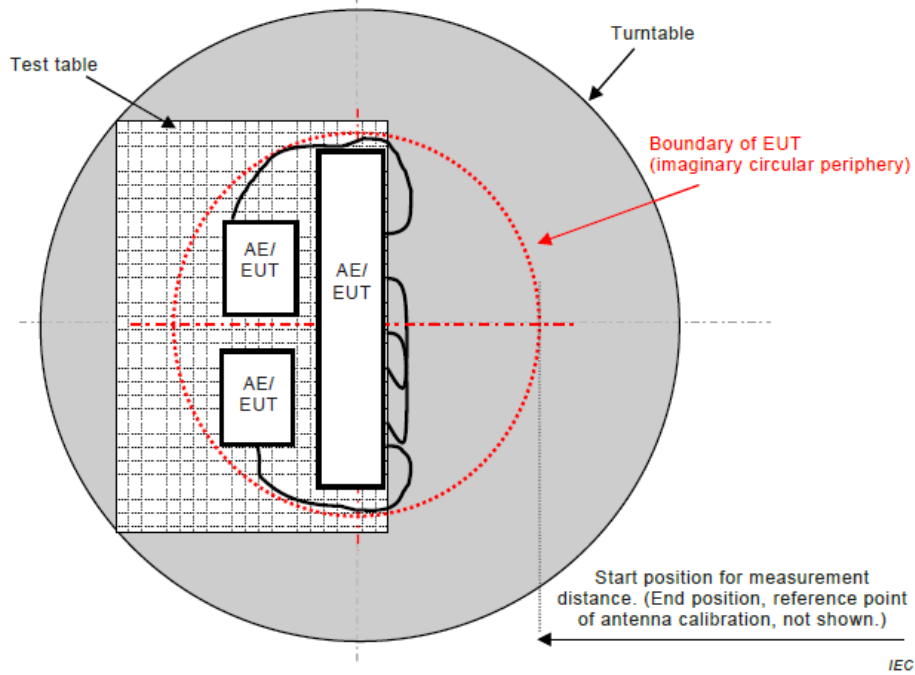
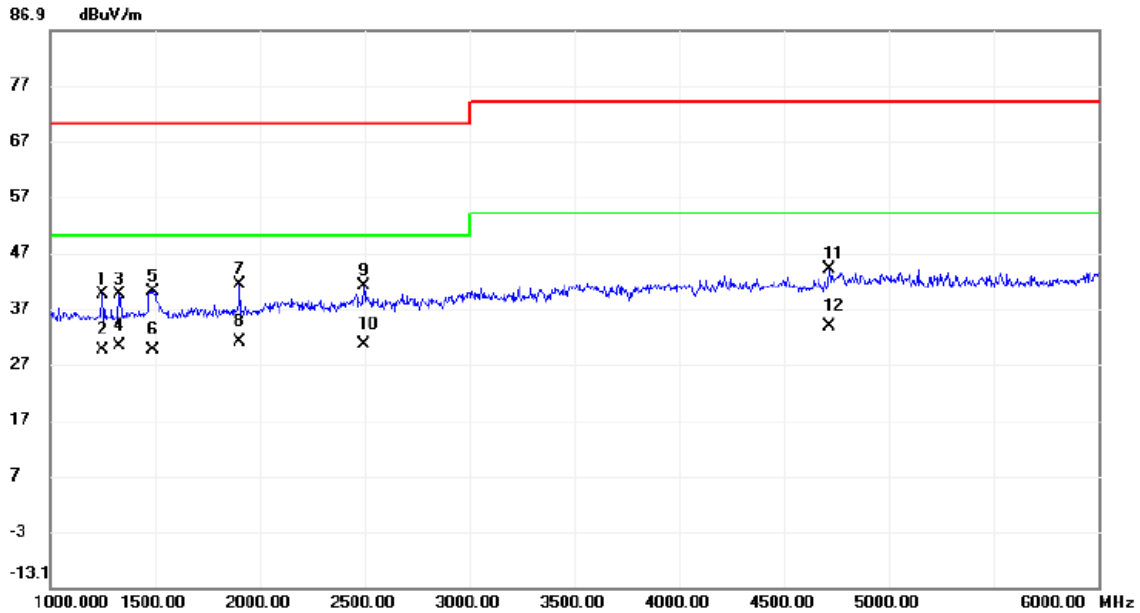

**Figure C.2 – Boundary of EUT, Local AE and associated cabling**



### 4.2.6 TEST RESULTS (ABOVE 1 GHZ)

Test Voltage	AC 230V/50Hz	Polarization	Vertical
Test Mode	Mode 3		



No.	Mk.	Freq. MHz	Reading Level dBuV	Correct Factor dB	Measure- ment dBuV/m	Limit dBuV/m	Margin dB	Detector	Comment
1		1250.000	44.88	-5.31	39.57	70.00	-30.43	peak	
2		1250.000	34.85	-5.31	29.54	50.00	-20.46	AVG	
3		1330.000	44.31	-4.74	39.57	70.00	-30.43	peak	
4		1330.000	34.97	-4.74	30.23	50.00	-19.77	AVG	
5		1492.500	43.68	-3.61	40.07	70.00	-29.93	peak	
6		1492.500	33.21	-3.61	29.60	50.00	-20.40	AVG	
7		1905.000	43.34	-2.18	41.16	70.00	-28.84	peak	
8	*	1905.000	33.26	-2.18	31.08	50.00	-18.92	AVG	
9		2497.500	40.78	0.18	40.96	70.00	-29.04	peak	
10		2497.500	30.24	0.18	30.42	50.00	-19.58	AVG	
11		4715.000	37.50	6.52	44.02	74.00	-29.98	peak	
12		4715.000	27.15	6.52	33.67	54.00	-20.33	AVG	

Test Voltage	AC 230V/50Hz	Polarization	Horizontal
Test Mode	Mode 3		

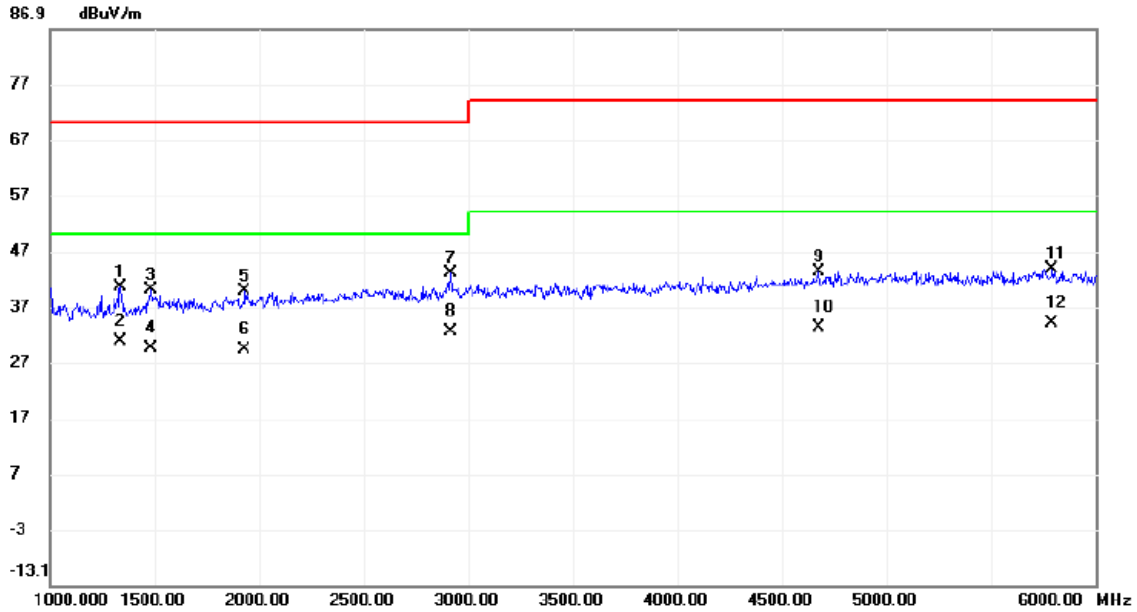

No.	Mk.	Freq. MHz	Reading Level dBuV	Correct Factor dB	Measure- ment dBuV/m	Limit dBuV/m	Margin dB	Detector	Comment
1		1337.500	45.26	-4.70	40.56	70.00	-29.44	peak	
2		1337.500	35.57	-4.70	30.87	50.00	-19.13	AVG	
3		1480.000	43.73	-3.70	40.03	70.00	-29.97	peak	
4		1480.000	33.15	-3.70	29.45	50.00	-20.55	AVG	
5		1930.000	41.91	-2.08	39.83	70.00	-30.17	peak	
6		1930.000	31.24	-2.08	29.16	50.00	-20.84	AVG	
7		2915.000	41.79	1.36	43.15	70.00	-26.85	peak	
8	*	2915.000	31.26	1.36	32.62	50.00	-17.38	AVG	
9		4675.000	36.88	6.36	43.24	74.00	-30.76	peak	
10		4675.000	26.85	6.36	33.21	54.00	-20.79	AVG	
11		5792.500	35.03	8.65	43.68	74.00	-30.32	peak	
12		5792.500	25.45	8.65	34.10	54.00	-19.90	AVG	

### 4.3 CONDUCTED EMISSION MEASUREMENT AT AC MAINS POWER PORTS

#### 4.3.1 LIMITS

Requirements for conducted emissions from AC mains power ports of Class B equipment

Frequency Range MHz	Coupling Device	Detector Type / bandwidth	Class B Limits (dB(μV) )
0.15 - 0.5	AMN	Quasi Peak / 9 kHz	66-56
0.5 - 5			56
5 - 30			60
0.15 - 0.5	AMN	Average / 9 kHz	56-46
0.5 - 5			46
5 - 30			50

NOTE:

(1) The test result calculated as following:

Measurement Value = Reading Level + Correct Factor

Correct Factor = Insertion Loss + Cable Loss + Attenuator Factor(if use)

Margin Level = Measurement Value – Limit Value

#### 4.3.2 MEASUREMENT INSTRUMENTS LIST

Item	Kind of Equipment	Manufacturer	Type No.	Series Model	Calibrated until
1	50Ω Terminator	SHX	TF2-3G-A	8122901	Feb. 28, 2021
2	TWO-LINE V-NETWORK	R&S	ENV216	100526	Mar. 01, 2021
3	EMI Test Receiver	R&S	ESR3	101862	Aug. 03, 2020
4	Artificial-Mains Network	SCHWARZBECK	NSLK 8127	8127685	Mar. 01, 2021
5	TRANSIENT LIMITER	EM	EM-7600	772	Mar. 01, 2021
6	Cable	N/A	RG400	N/A(12m)	Mar. 10, 2021
7	Measurement Software	Farad	EZ-EMC Ver.NB-03A1-01	N/A	N/A

Remark: "N/A" denotes no model name, serial no. or calibration specified.

All calibration period of equipment list is one year.

#### 4.3.3 TEST PROCEDURE

- The EUT was placed 0.8 meters from the horizontal ground plane with EUT being connected to the power mains through a line impedance stabilization network (LISN). All other support equipments powered from additional LISN(s). The LISN provide 50 Ohm/ 50uH of coupling impedance for the measuring instrument.
- Interconnecting cables that hang closer than 40 cm to the ground plane shall be folded back and forth in the center forming a bundle 30 to 40 cm long.
- I/O cables that are not connected to a peripheral shall be bundled in the center. The end of the cable may be terminated, if required, using the correct terminating impedance. The overall length shall not exceed 1 m.
- LISN at least 80 cm from nearest part of EUT chassis.
- For the actual test configuration, please refer to the related Item –EUT Test Photos.

#### 4.3.4 DEVIATION FROM TEST STANDARD

No deviation

### 4.3.5 TEST SETUP

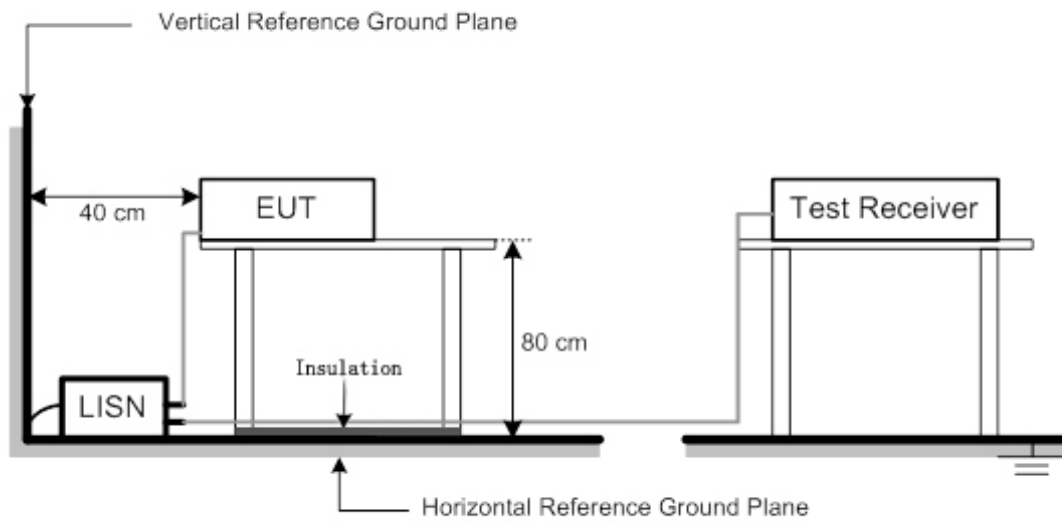

### 4.3.6 TEST RESULTS

Test Voltage	AC 230V/50Hz	Phase	Line
Test Mode	Mode 3		

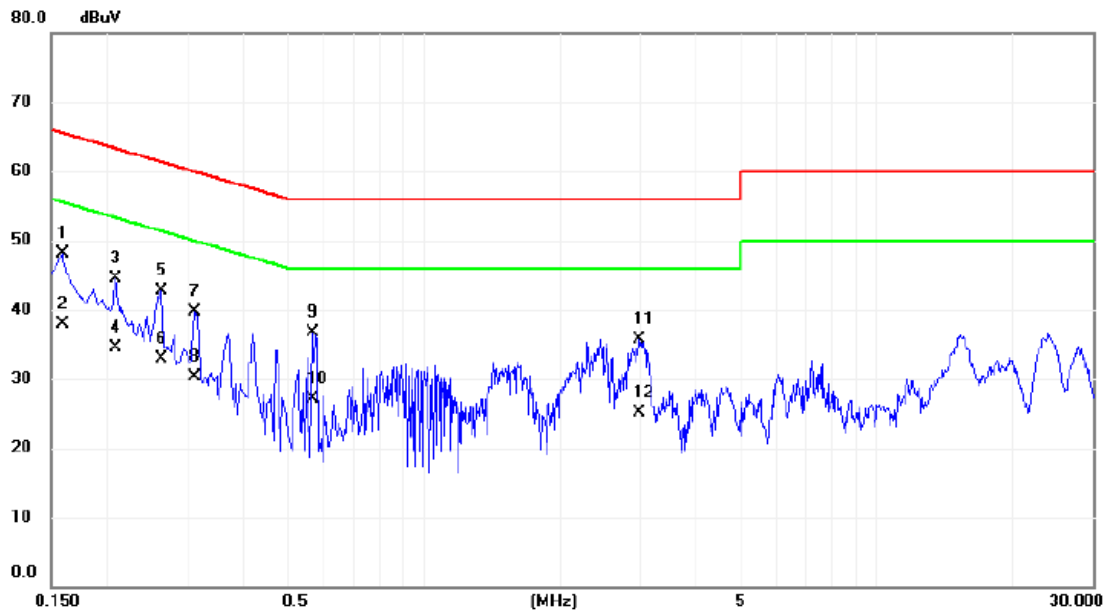

No.	Mk.	Freq. MHz	Reading Level dBuV	Correct Factor dB	Measure- ment dBuV	Limit dBuV	Margin dB	Detector	Comment
1	*	0.1590	37.58	10.48	48.06	65.52	-17.46	QP	
2		0.1590	27.50	10.48	37.98	55.52	-17.54	AVG	
3		0.2084	34.00	10.48	44.48	63.27	-18.79	QP	
4		0.2084	24.10	10.48	34.58	53.27	-18.69	AVG	
5		0.2625	32.15	10.48	42.63	61.35	-18.72	QP	
6		0.2625	22.40	10.48	32.88	51.35	-18.47	AVG	
7		0.3120	29.20	10.49	39.69	59.92	-20.23	QP	
8		0.3120	19.80	10.49	30.29	49.92	-19.63	AVG	
9		0.5684	26.25	10.52	36.77	56.00	-19.23	QP	
10		0.5684	16.50	10.52	27.02	46.00	-18.98	AVG	
11		2.9984	24.97	10.69	35.66	56.00	-20.34	QP	
12		2.9984	14.50	10.69	25.19	46.00	-20.81	AVG	

Test Voltage	AC 230V/50Hz	Phase	Neutral
Test Mode	Mode 3		

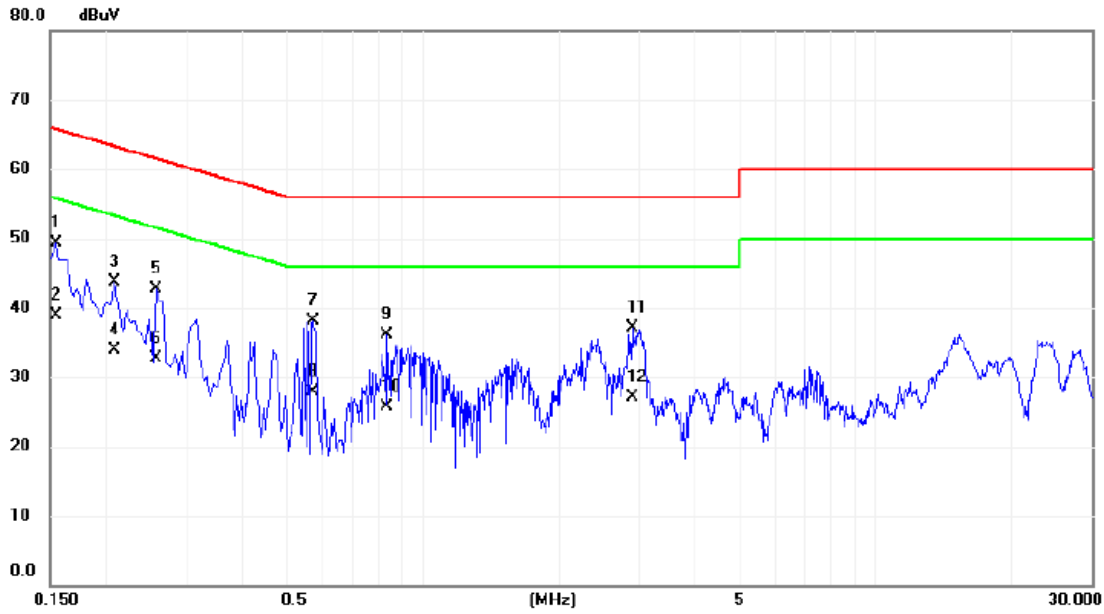

No.	Mk.	Freq.	Reading	Correct	Measure-	Limit	Margin		
		MHz	dBuV	Factor	ment	dBuV	dB	Detector	Comment
1	*	0.1544	38.83	10.43	49.26	65.76	-16.50	QP	
2		0.1544	28.50	10.43	38.93	55.76	-16.83	AVG	
3		0.2084	33.20	10.45	43.65	63.27	-19.62	QP	
4		0.2084	23.50	10.45	33.95	53.27	-19.32	AVG	
5		0.2580	32.18	10.47	42.65	61.50	-18.85	QP	
6		0.2580	22.30	10.47	32.77	51.50	-18.73	AVG	
7		0.5730	27.52	10.49	38.01	56.00	-17.99	QP	
8		0.5730	17.50	10.49	27.99	46.00	-18.01	AVG	
9		0.8340	25.66	10.51	36.17	56.00	-19.83	QP	
10		0.8340	15.20	10.51	25.71	46.00	-20.29	AVG	
11		2.8950	26.38	10.64	37.02	56.00	-18.98	QP	
12		2.8950	16.40	10.64	27.04	46.00	-18.96	AVG	

## 5. HARMONIC AND FLICKER TEST

### 5.1 HARMONIC CURRENT EMISSIONS

#### 5.1.1 LIMITS

The power consumption is less than 75W, there is no limit applied.

#### 5.1.2 MEASUREMENT INSTRUMENTS LIST

Item	Kind of Equipment	Manufacturer	Type No.	Series Model	Calibrated until
1	Harmonics and Flicker Analyzer	California Instruments	PACS-1	72344	Aug. 03, 2020
2	3KVA AC Power source	California Instruments	3001ix	56309	Aug. 03, 2020
3	Measurement Software	California	CTS4.0 Version 4.21	N/A	N/A

Remark: "N/A" denotes no model no., no serial No. or no calibration specified.

All calibration period of equipment list is one year.

#### 5.1.3 TEST PROCEDURE

- a. The EUT was placed on the top of a wooden table 0.8 meters above the ground and operated to produce the maximum harmonic components under normal operating conditions.
- b. The correspondent test program of test instrument to measure the current harmonics emanated from EUT is chosen. The measure time shall be not less than the time necessary for the EUT to be exercised.

#### 5.1.4 DEVIATION FROM TEST STANDARD

No deviation

#### 5.1.5 TEST SETUP

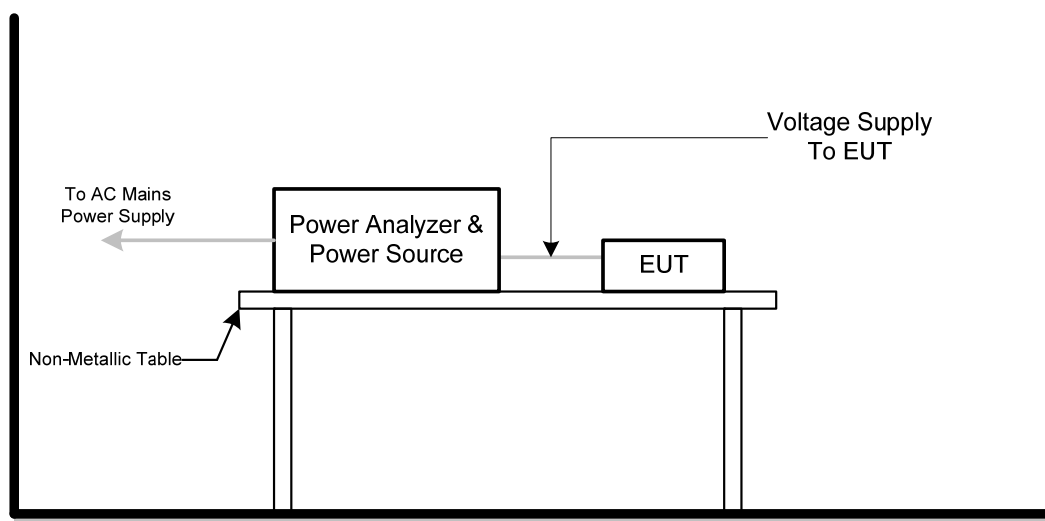

### 5.1.6 TEST RESULTS

Harmonic - Class D	
Test Voltage	AC 230V/50Hz
Test Mode	Mode 3

#### Current & voltage waveforms

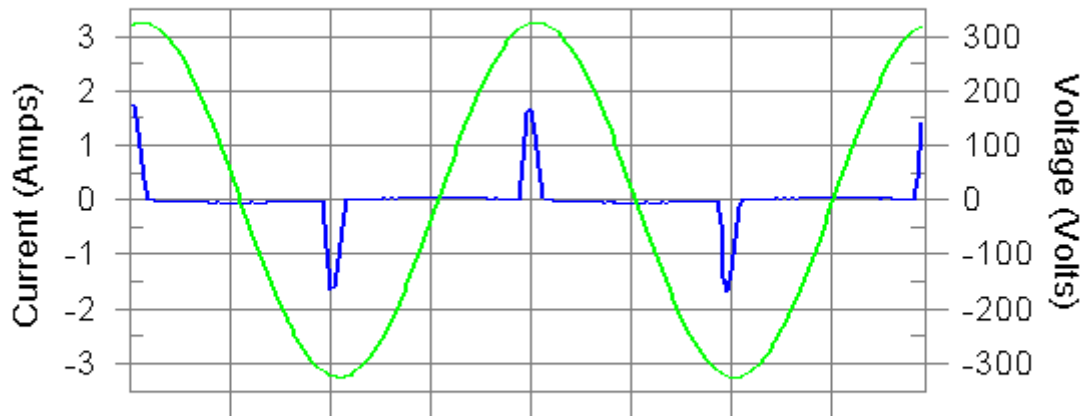

#### Harmonics and Class D limit line      European Limits

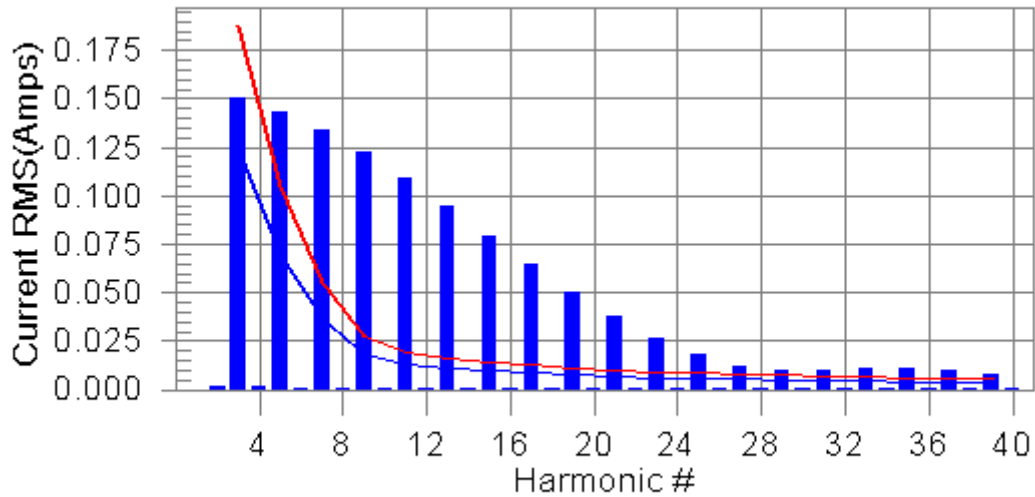

**Test result: N/L      Worst harmonics H0-0.0% of 150% limit, H0-0% of 100% limit**



## Current Test Result Summary (Run time)

Test Voltage	AC 230V/50Hz
Test Mode	Mode 3

## Highest parameter values during test:

V RMS (Volts): 230.05	Frequency(Hz): 50.00
I Peak (Amps): 1.771	I RMS (Amps): 0.390
I Fund (Amps): 0.167	Crest Factor: 4.688
Power (Watts): 36.8	Power Factor: 0.414

Ham#	Harms(avg)	100%Limit	%of Limit	Harms(max)	150%Limit	%of Limit	Status
2	0.001	0.000	N/A	0.002	0.000	N/A	N/L
3	0.150	0.125	N/A	0.158	0.188	N/A	N/L
4	0.001	0.000	N/A	0.002	0.000	N/A	N/L
5	0.143	0.070	N/A	0.150	0.105	N/A	N/L
6	0.001	0.000	N/A	0.001	0.000	N/A	N/L
7	0.134	0.037	N/A	0.140	0.055	N/A	N/L
8	0.001	0.000	N/A	0.001	0.000	N/A	N/L
9	0.123	0.018	N/A	0.128	0.028	N/A	N/L
10	0.001	0.000	N/A	0.001	0.000	N/A	N/L
11	0.109	0.013	N/A	0.113	0.019	N/A	N/L
12	0.001	0.000	N/A	0.001	0.000	N/A	N/L
13	0.095	0.011	N/A	0.098	0.017	N/A	N/L
14	0.000	0.000	N/A	0.001	0.000	N/A	N/L
15	0.079	0.010	N/A	0.082	0.014	N/A	N/L
16	0.000	0.000	N/A	0.001	0.000	N/A	N/L
17	0.064	0.008	N/A	0.066	0.013	N/A	N/L
18	0.000	0.000	N/A	0.001	0.000	N/A	N/L
19	0.050	0.007	N/A	0.051	0.011	N/A	N/L
20	0.000	0.000	N/A	0.001	0.000	N/A	N/L
21	0.037	0.007	N/A	0.038	0.010	N/A	N/L
22	0.000	0.000	N/A	0.001	0.000	N/A	N/L
23	0.026	0.006	N/A	0.027	0.009	N/A	N/L
24	0.000	0.000	N/A	0.001	0.000	N/A	N/L
25	0.018	0.006	N/A	0.018	0.008	N/A	N/L
26	0.000	0.000	N/A	0.001	0.000	N/A	N/L
27	0.012	0.005	N/A	0.013	0.008	N/A	N/L
28	0.000	0.000	N/A	0.001	0.000	N/A	N/L
29	0.010	0.005	N/A	0.011	0.007	N/A	N/L
30	0.000	0.000	N/A	0.000	0.000	N/A	N/L
31	0.010	0.005	N/A	0.011	0.007	N/A	N/L
32	0.000	0.000	N/A	0.000	0.000	N/A	N/L
33	0.011	0.004	N/A	0.011	0.006	N/A	N/L
34	0.000	0.000	N/A	0.000	0.000	N/A	N/L
35	0.010	0.004	N/A	0.011	0.006	N/A	N/L
36	0.000	0.000	N/A	0.000	0.000	N/A	N/L
37	0.009	0.004	N/A	0.010	0.006	N/A	N/L
38	0.000	0.000	N/A	0.000	0.000	N/A	N/L
39	0.008	0.004	N/A	0.008	0.005	N/A	N/L
40	0.000	0.000	N/A	0.000	0.000	N/A	N/L

Note: The EUT power level is below 75.0 Watts and therefore has no defined limits

## Voltage Source Verification Data (Run time)

Test Voltage	AC 230V/50Hz
Test Mode	Mode 3

## Highest parameter values during test:

Voltage (Vrms): 230.05	Frequency(Hz): 50.00
I Peak (Amps): 1.771	I RMS (Amps): 0.390
I Fund (Amps): 0.167	Crest Factor: 4.688
Power (Watts): 36.8	Power Factor: 0.414

Harmon#	Harmonics V-rms	Limit V-rms	% of Limit	Status
2	0.116	0.460	25.31	OK
3	0.565	2.070	27.29	OK
4	0.064	0.460	13.87	OK
5	0.039	0.920	4.28	OK
6	0.024	0.460	5.24	OK
7	0.077	0.690	11.17	OK
8	0.019	0.460	4.14	OK
9	0.050	0.460	10.91	OK
10	0.021	0.460	4.52	OK
11	0.074	0.230	32.30	OK
12	0.019	0.230	8.30	OK
13	0.059	0.230	25.53	OK
14	0.015	0.230	6.65	OK
15	0.066	0.230	28.81	OK
16	0.016	0.230	6.76	OK
17	0.046	0.230	19.86	OK
18	0.012	0.230	5.17	OK
19	0.050	0.230	21.66	OK
20	0.015	0.230	6.43	OK
21	0.040	0.230	17.20	OK
22	0.012	0.230	5.13	OK
23	0.030	0.230	13.07	OK
24	0.006	0.230	2.65	OK
25	0.019	0.230	8.19	OK
26	0.008	0.230	3.36	OK
27	0.020	0.230	8.87	OK
28	0.009	0.230	3.92	OK
29	0.022	0.230	9.38	OK
30	0.006	0.230	2.50	OK
31	0.015	0.230	6.59	OK
32	0.006	0.230	2.54	OK
33	0.021	0.230	8.99	OK
34	0.003	0.230	1.35	OK
35	0.020	0.230	8.70	OK
36	0.003	0.230	1.46	OK
37	0.018	0.230	7.65	OK
38	0.004	0.230	1.66	OK
39	0.013	0.230	5.59	OK
40	0.007	0.230	2.96	OK

## 5.2 VOLTAGE CHANGES, VOLTAGE FLUCTUATIONS AND FLICKER TEST

### 5.2.1 LIMITS

Tests	Limits	Descriptions
	EN 61000-3-3	
Pst	$\leq 1.0$ , $T_p= 10$ min.	Short Term Flicker Indicator
Plt	$\leq 0.65$ , $T_p=2$ hr.	Long Term Flicker Indicator
dc	$\leq 3.3\%$	Relative Steady-State V-Chang
dmax	$\leq 4\%$	Maximum Relative V-change
d (t)	$\leq 500$ ms	Relative V-change characteristic

### 5.2.2 MEASUREMENT INSTRUMENTS LIST

Item	Kind of Equipment	Manufacturer	Type No.	Series Model	Calibrated until
1	Harmonics and Flicker Analyzer	California Instruments	PACS-1	72344	Aug. 03, 2020
2	3KVA AC Power source	California Instruments	3001ix	56309	Aug. 03, 2020
3	Measurement Software	California	CTS4.0 Version 4.21	N/A	N/A

Remark: "N/A" denotes no model no., no serial No. or no calibration specified.

All calibration period of equipment list is one year.

### 5.2.3 TEST PROCEDURE

- Tests was performed according to the Test Conditions/Assessment of Voltage Fluctuations specified in EN 61000-3-3 depend on which standard adopted for compliance measurement.
- All types of harmonic current and/or voltage fluctuation in this report are assessed by direct measurement using flicker-meter.

### 5.2.4 DEVIATION FROM TEST STANDARD

No deviation

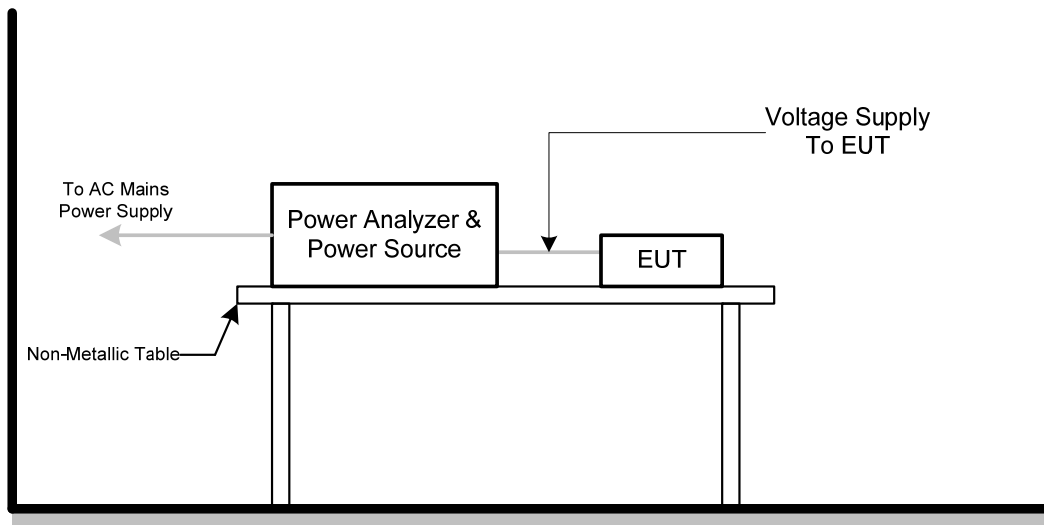
**5.2.5 TEST SETUP**

### 5.2.6 TEST RESULTS

Test Voltage	AC 230V/50Hz
Test Mode	Mode 3

**Pst and limit line**

**European Limits**

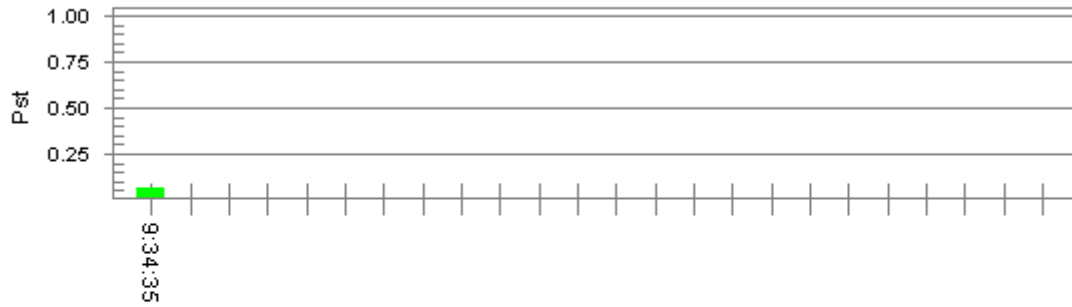

**Plt and limit line**



**Parameter values recorded during the test:**

Vrms at the end of test (Volt):	230.00		
T-max (mS):	0	Test limit (mS):	500.0 Pass
Highest dc (%):	0.00	Test limit (%):	3.30 Pass
Highest dmax (%):	0.00	Test limit (%):	4.00 Pass
Highest Pst (10 min. period):	0.064	Test limit:	1.000 Pass
Highest Plt (2 hr. period):	0.028	Test limit:	0.650 Pass

## 6. EMC IMMUNITY TEST

### 6.1 STANDARD COMPLIANCE/SEVERITY LEVEL/CRITERIA

Tests Standard No.	Test Specification Level	Test Ports	Criteria
Electrostatic discharge IEC 61000-4-2 (ESD)	±8 kV air discharge ±4 kV contact discharge (Direct Mode)	Enclosure	B
	±4kV HCP discharge ±4kV VCP discharge (Indirect Mode)	Enclosure	B
Radiated, radio-frequency, electromagnetic field immunity IEC 61000-4-3 (RS)	80 MHz to 1000 MHz 3V/m(unmodulated, r.m.s), 1 kHz, 80% AM modulated	Enclosure	A
Electrical fast transient/burst immunity IEC 61000-4-4 (EFT)	±0.5kV(peak) 5/50ns Tr/Th 5kHz Repetition Frequency (100kHz Repetition Frequency for xDSL ports)	Signal ports and telecommunication ports (Only applicable to cable length>3 m)	B
	±0.5kV(peak) 5/50ns Tr/Th 5kHz Repetition Frequency	DC Power Ports	B
	±1 kV(peak) 5/50ns Tr/Th 5kHz Repetition Frequency	AC Power Ports	B
Surge immunity IEC 61000-4-5 (Surge)	±1 kV(peak) 10/700 Tr/Th $\mu$ s (without primary protection)	Signal ports and telecommunication ports (applicable only to ports connect directly to outdoor cables)	C
	±4 kV(peak) 10/700 Tr/Th $\mu$ s (with primary protectors fitted)		C
	±0.5 kV(peak) 1.2/50(8/20) Tr/Th $\mu$ s	DC Power Ports (applicable only to ports connect directly to outdoor cables)	B
	±1 kV(peak) 1.2/50(8/20) Tr/Th $\mu$ s (line to line)	AC Power Ports	B
	±2 kV(peak) 1.2/50(8/20) Tr/Th $\mu$ s (line to earth or ground)		B

Immunity to conducted disturbances, induced by radio-frequency fields IEC 61000-4-6 (CS)	0.15 MHz to 80 MHz 3V(unmodulated, r.m.s), 1kHz 80%, AM 150Ω source impedance	Signal ports and telecommunication ports (Only applicable to cable length>3 m)	A
	0.15 MHz to 80 MHz 3V(unmodulated, r.m.s), 1kHz 80%, AM 150Ω source impedance	DC Power Ports	A
	0.15 MHz to 80 MHz 3V(unmodulated, r.m.s), 1kHz 80%, AM 150Ω source impedance	AC Power Ports	A
Power frequency magnetic field immunity IEC 61000-4-8 (PFMF)	50 Hz or 60Hz, 1A/m(r.m.s)	Enclosure	A
Voltage dips, short interruptions and voltage variations immunity IEC 61000-4-11 (Dips)	Voltage reduction > 95% 0.5 cycle Voltage reduction 30% 25 cycle Voltage reduction > 95% 250 cycle	AC Power Ports	B C C

## 6.2 GENERAL PERFORMANCE CRITERIA

According to **EN55024** standard, the general performance criteria as following:

<b>Criterion A</b>	<p>The equipment shall continue to operate as intended without operator intervention. No degradation of performance or loss of function is allowed below a performance level specified by the manufacturer when the equipment is used as intended. The performance level may be replaced by a permissible loss of performance.</p> <p>If the minimum performance level or the permissible performance loss is not specified by the manufacturer, then either of these may be derived from the product description and documentation, and by what the user product description and documentation, and by what the user may reasonably expect from the equipment if used as intended.</p>
<b>Criterion B</b>	<p>After the test, the equipment shall continue to operate as intended without operator Intervention. No degradation of performance or loss of function is allowed, after the application of the phenomenon below a performance level specified by the manufacturer, when the equipment is used as intended. The performance level may be replaced by a permissible loss of performance.</p> <p>During the test, degradation of performance is allowed. However, no change of operating state if stored data allowed to persist after the test. If the minimum performance level (or the permissible performance loss ) is not specified by the manufacturer, then either of these may be derived from the product description and documentation, and by what the user may reasonably expect from the equipment if used as intended.</p>
<b>Criterion C</b>	<p>Loss of function is allowed, provided the function is self-recoverable, or can be restored by the operation of the controls by the user in accordance with the manufacturer's instructions.</p> <p>Functions, and/or information stored in non-volatile memory, or protected by a battery backup, shall not be lost.</p>



## 6.3 ELECTROSTATIC DISCHARGE IMMUNITY TEST (ESD)

### 6.3.1 TEST SPECIFICATION

Basic Standard	EN 61000-4-2
Discharge Impedance	330 ohm / 150 pF
Required Performance	B
Discharge Voltage	Air Discharge: $\pm 2$ kV, $\pm 4$ kV, $\pm 8$ kV Contact Discharge: $\pm 2$ kV, $\pm 4$ kV
Polarity	Positive & Negative
Number of Discharge	Air Discharge: min. 20 times at each test point Contact Discharge: min. 200 times in total
Discharge Mode	Single Discharge
Discharge Period	1 second minimum

### 6.3.2 MEASUREMENT INSTRUMENTS

Item	Kind of Equipment	Manufacturer	Type No.	Serial No.	Calibrated until
1	ESD Simulator	EM TEST	dito	305018	Jul. 17, 2020

Remark: "N/A" denotes no model name, no serial No. or no calibration specified.

All calibration period of equipment list is one year.

### 6.3.3 TEST PROCEDURE

The test generator necessary to perform direct and indirect application of discharges to the EUT in the following manner:

- a. Contact discharge was applied to conductive surfaces (Direct) and coupling planes (Indirect) of the EUT.

During the test, it was performed with single discharges. For the single discharge time between successive single discharges was at least 1 second. The EUT shall be exposed to at least 200 discharges, 100 each at negative and positive polarity, at a minimum of four test points. One of the test points shall be subjected to at least 50 indirect discharges to the center of the front edge of the horizontal coupling plane. The remaining three test points shall each receive at least 50 direct contact discharges.

If no direct contact test points are available, then at least 200 indirect discharges shall be applied in the indirect mode. Test shall be performed at a maximum repetition rate of one discharge per second.

Vertical Coupling Plane (VCP):

The coupling plane, of dimensions 0.5m x 0.5m, is placed parallel to, and positioned at a distance 0.1m from, the EUT, with the Discharge Electrode touching the coupling plane.

The four faces of the EUT will be performed with electrostatic discharge.

Horizontal Coupling Plane (HCP):

The coupling plane is placed under to the EUT. The generator shall be positioned vertically at a distance of 0.1m from the EUT, with the Discharge Electrode touching the coupling plane.

The four faces of the EUT will be performed with electrostatic discharge.

- b. Air discharges at insulation surfaces of the EUT.

It was at least ten single discharges with positive and negative at the same selected point.

- c. For TABLE-TOP equipment:

The configuration consisted of a wooden table 0.8 meters high standing on the Ground Reference Plane. The GRP consisted of a sheet of aluminum at least 0.25mm thick, and 2.5 meters square connected to the protective grounding system. A Horizontal Coupling Plane (1.6m x 0.8m) was placed on the table and attached to the GRP by means of a cable with 940k total impedance. The equipment under test was installed in a representative system as described in IEC 61000-4-2, and its cables were placed on the HCP and isolated by an insulating support of 0.5mm thickness. A distance of 1-meter minimum was provided between the EUT and the walls of the laboratory and any other metallic structure.

### 6.3.4 DEVIATION FROM TEST STANDARD

No deviation

### 6.3.5 TEST SETUP

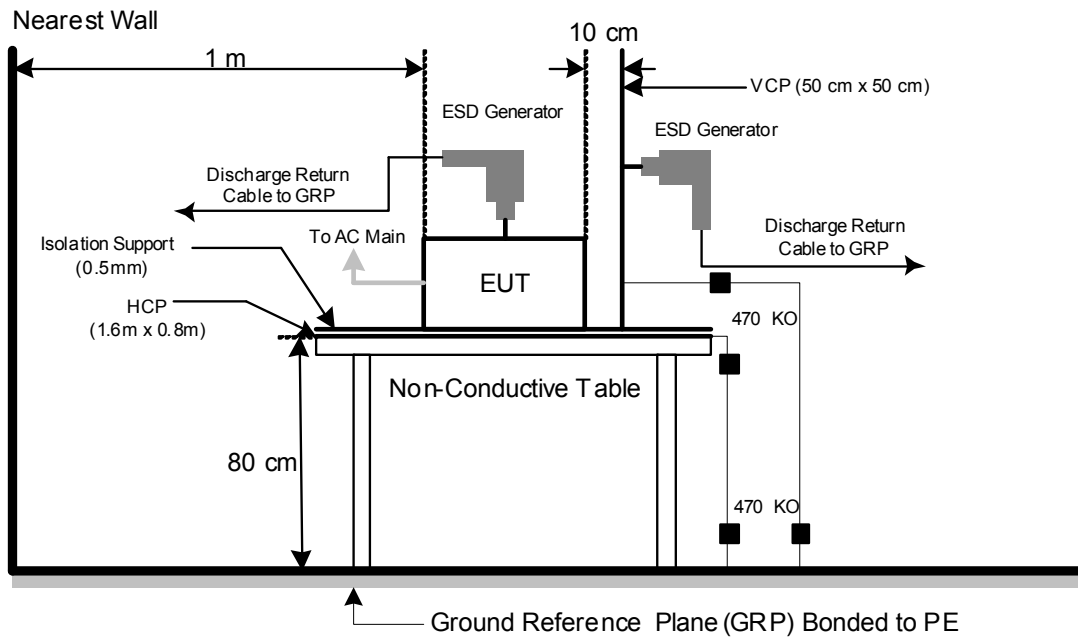

### 6.3.6 TEST RESULTS

Test Voltage	AC 230V/50Hz
Test Mode	Mode 1 ~ Mode 8

Mode	Air Discharge						Contact Discharge									
	2kV		4kV		8kV		- kV		2kV		4kV		- kV			
Location	P	N	P	N	P	N	P	N	P	N	P	N	P	N		
1	A	A	A	A	A	A	-	-	A	A	A	A	-	-		
2	A	A	A	A	A	A	-	-	-	-	-	-	-	-		
3	A	A	A	A	A	A	-	-	-	-	-	-	-	-		
4	A	A	A	A	A	A	-	-	-	-	-	-	-	-		
5	A	A	A	A	A	A	-	-	-	-	-	-	-	-		
6	A	A	A	A	A	A	-	-	-	-	-	-	-	-		
7	A	A	A	A	A	A	-	-	-	-	-	-	-	-		
8	A	A	A	A	A	A	-	-	-	-	-	-	-	-		
Criteria	B						-		B						-	
Result	A						-		A						-	

Mode	HCP Contact Discharge						VCP Contact Discharge									
	2kV		4kV		- kV		2kV		4kV		- kV					
Location	P	N	P	N	P	N	P	N	P	N	P	N				
1	A	A	A	A	-	-	A	A	A	A	-	-				
2	A	A	A	A	-	-	A	A	A	A	-	-				
3	A	A	A	A	-	-	A	A	A	A	-	-				
4	A	A	A	A	-	-	A	A	A	A	-	-				
Criteria	B						-		B						-	
Result	A						-		A						-	

Note:

- 1) P/N denotes the Positive/Negative polarity of the output voltage.
- 2) N/A - denotes test is not applicable in this test report

PHOTO(S) SHOWN THE LOCATION(S) OF ESD EVALUATED

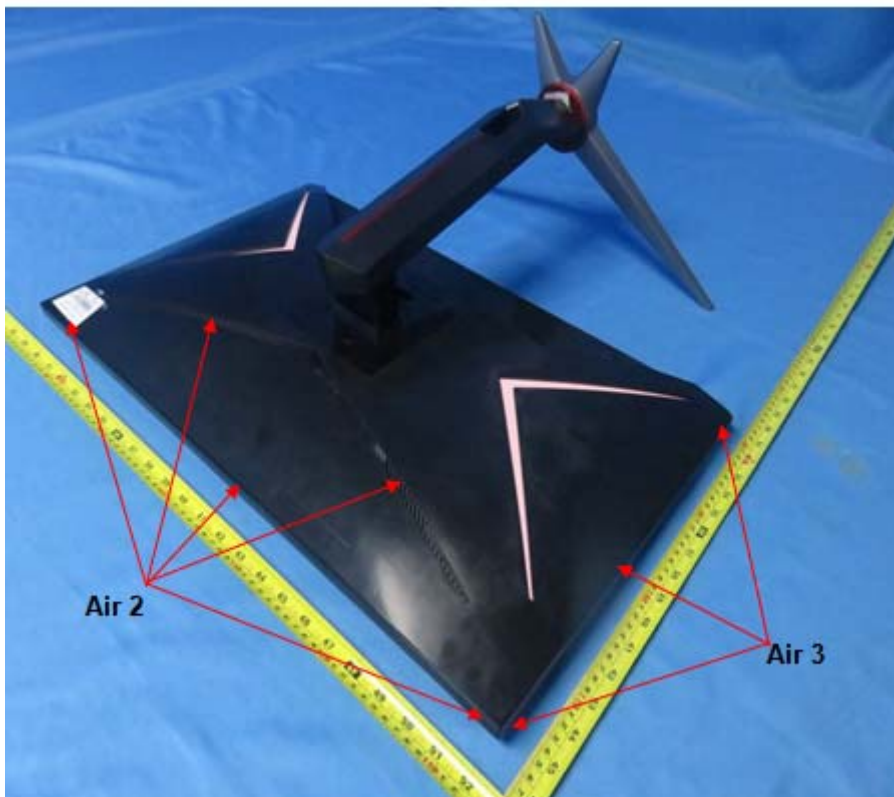
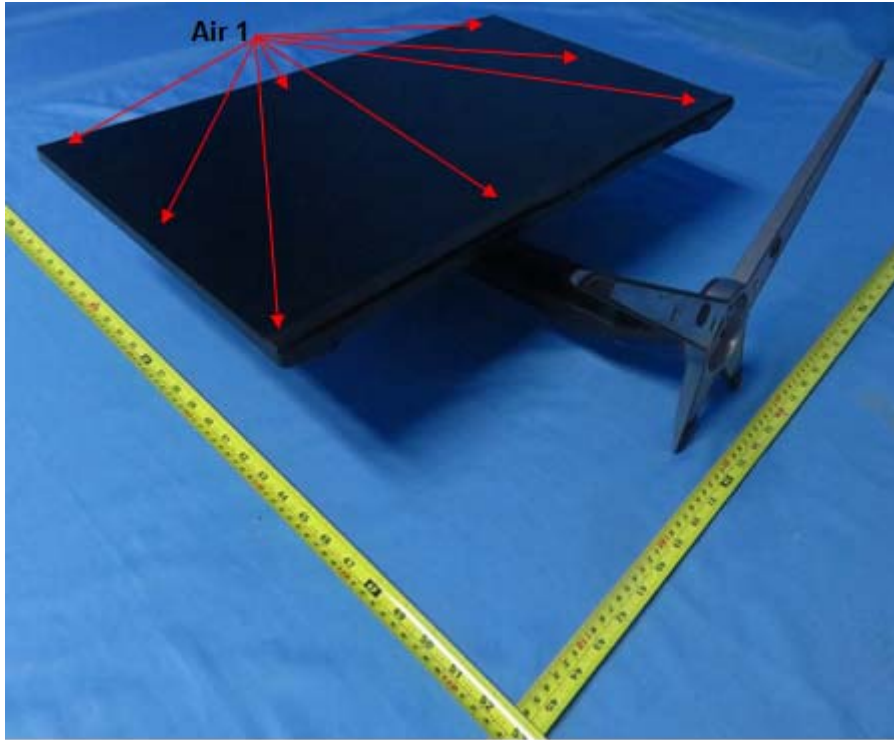

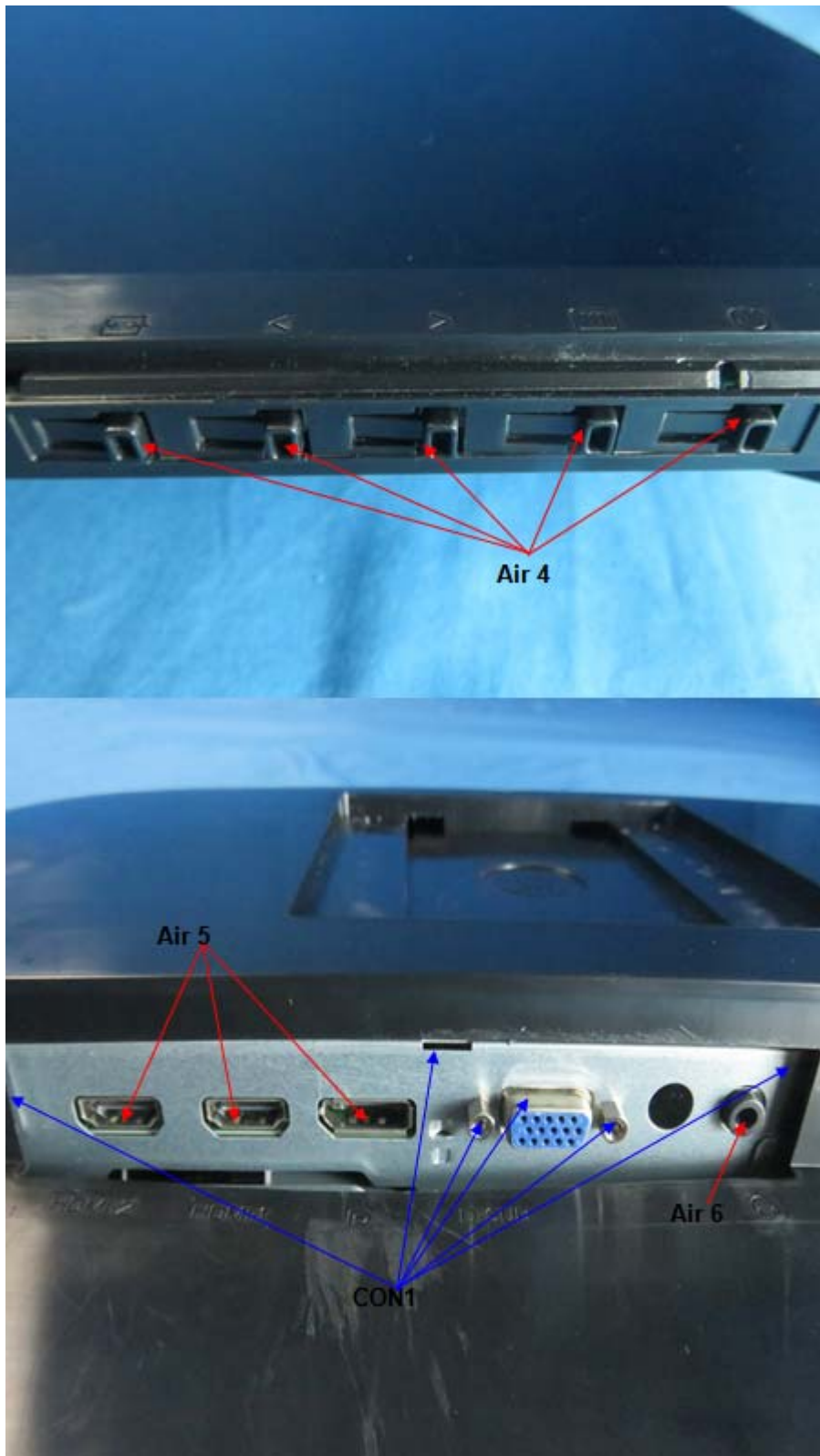

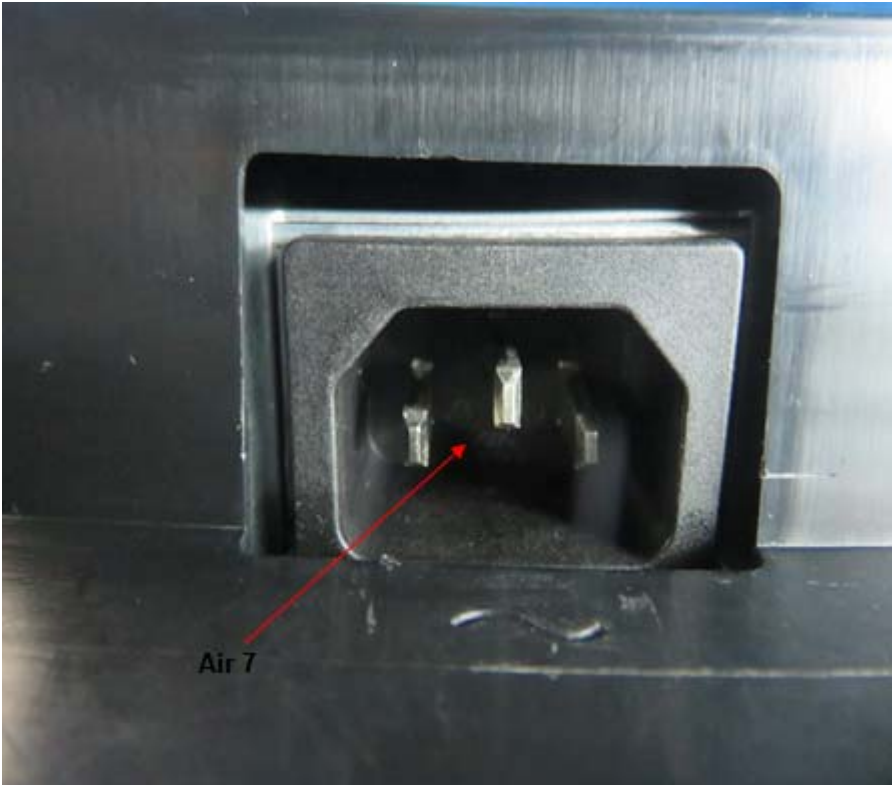

## 6.4 RADIATED, RADIO-FREQUENCY, ELECTROMAGNETIC FIELD IMMUNITY TEST (RS)

### 6.4.1 TEST SPECIFICATION

Basic Standard	EN 61000-4-3
Required Performance	A
Frequency Range	80 MHz - 1000 MHz
Field Strength	3 V/m(unmodulated, r.m.s)
Modulation	1 kHz Sine Wave, 80%, AM Modulation
Frequency Step	1% of fundamental
Polarity of Antenna	Horizontal and Vertical
Test Distance	3 m
Antenna Height	1.55 m
Dwell Time	3 seconds

### 6.4.2 MEASUREMENT INSTRUMENTS

Item	Kind of Equipment	Manufacturer	Type No.	Serial No.	Calibrated until
1	MXG Analog Signal Generator	Agilent	N5181A	MY49060710	Aug. 03, 2020
2	Power amplifier	MILMEGA	AS1860-50	1064834	Aug. 20, 2020
3	Antenna	ETS	3142C	47662	Apr. 23, 2020
4	Measurement Software	TOYO	IM5/RS Ver 3.8.050	N/A	N/A

Remark: "N/A" denotes no model name, no serial No. or no calibration specified.

All calibration period of equipment list is one year.

### 6.4.3 TEST PROCEDURE

The EUT and support equipment are in a fully-anechoic chamber.

The testing distance from antenna to the EUT was 3 meters.

For TABLE-TOP equipment:

The EUT installed in a representative system as described in IEC 61000-4-3 was placed on a non-conductive table 0.8 meters in height. The system under test was connected to the power and signal wire according to relevant installation instructions.

- a. The field strength level was 3 V/m(unmodulated, r.m.s).
- b. The frequency range is swept from 80 MHz to 1000 MHz, with the signal 80% amplitude modulated with a 1 kHz sine wave. Where the frequency range is swept incrementally, the step size was 1% of fundamental.
- c. The dwell time at each frequency shall be not less than the time necessary for the EUT to be able to respond.
- d. The test was performed with the EUT exposed to both vertically and horizontally polarized fields on each of the four sides.

### 6.4.4 DEVIATION FROM TEST STANDARD

No deviation

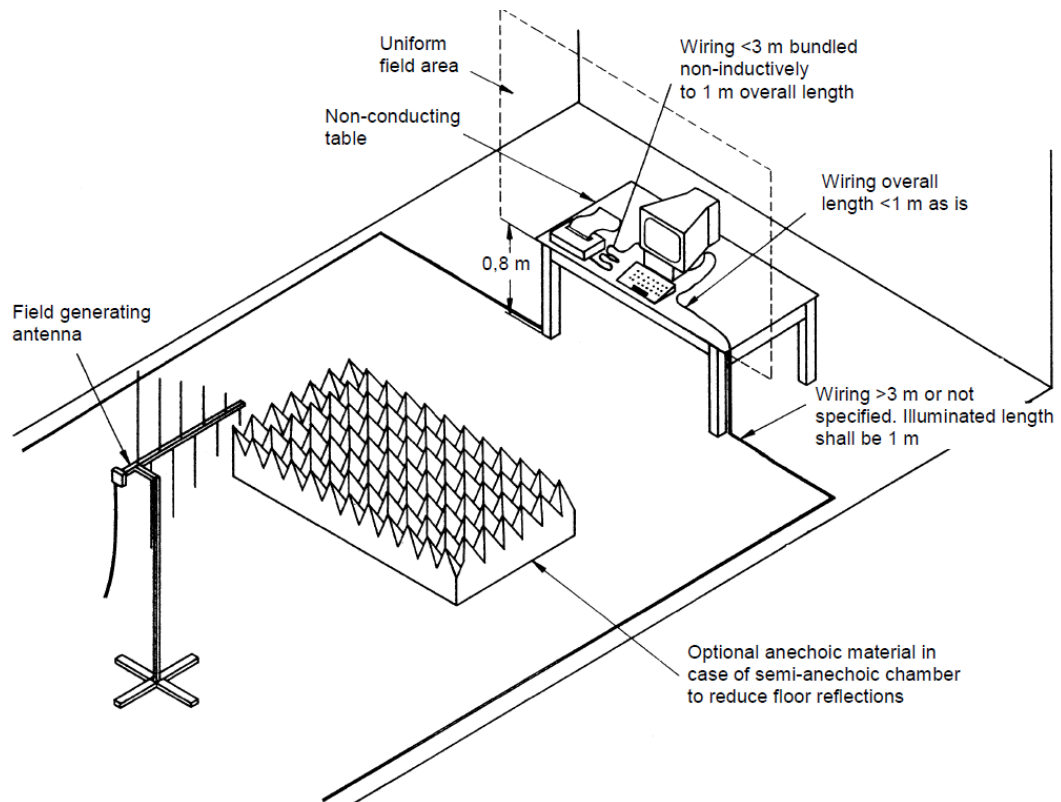
**6.4.5 TEST SETUP**



### 6.4.6 TEST RESULTS

Test Voltage	AC 230V/50Hz
Test Mode	Mode 1 ~ Mode 8

Frequency Range (MHz)	RF Field Position	R.F. Field Strength	Modulation	Azimuth	Criterion	Result
80 - 1000	H / V	3V/m	AM Modulated 1000Hz, 80%	0	A	A
				90		
				180		
				270		

## 6.5 ELECTRICAL FAST TRANSIENT/BURST IMMUNITY TEST (EFT/BURST)

### 6.5.1 TEST SPECIFICATION

Basic Standard	EN 61000-4-4
Required Performance	B
Test Voltage	Power Line: $\pm 1$ kV
Polarity	Positive & Negative
Impulse Frequency	5 kHz: except for xDSL ports.
Impulse Wave shape	5/50 ns
Burst Duration	15 ms
Burst Period	300 ms
Test Duration	1 min.

### 6.5.2 MEASUREMENT INSTRUMENTS

Item	Kind of Equipment	Manufacturer	Type No.	Serial No.	Calibrated until
1	THE MODULAR SOLUTION FOR 6 KV APPLICATIONS	Teseq	NSG 3060	1423	Aug. 10, 2020

Remark: "N/A" denotes no model name, no serial No. or no calibration specified.

All calibration period of equipment list is one year.

### 6.5.3 TEST PROCEDURE

For TABLE-TOP equipment:

The configuration consisted of a wooden table (0.8m high) standing on the Ground Reference Plane and should be located 0.1 m $\pm$  0.01m above the Ground Reference Plane. The GRP consisted of a sheet of aluminum (at least 0.25mm thick and 2.5m square) connected to the protective grounding system. A minimum distance of 0.5m was provided between the EUT and the walls of the laboratory or any other metallic structure.

- a. Both positive and negative polarity discharges were applied.
- b. The duration time of each test sequential was 1 minute.

### 6.5.4 DEVIATION FROM TEST STANDARD

No deviation

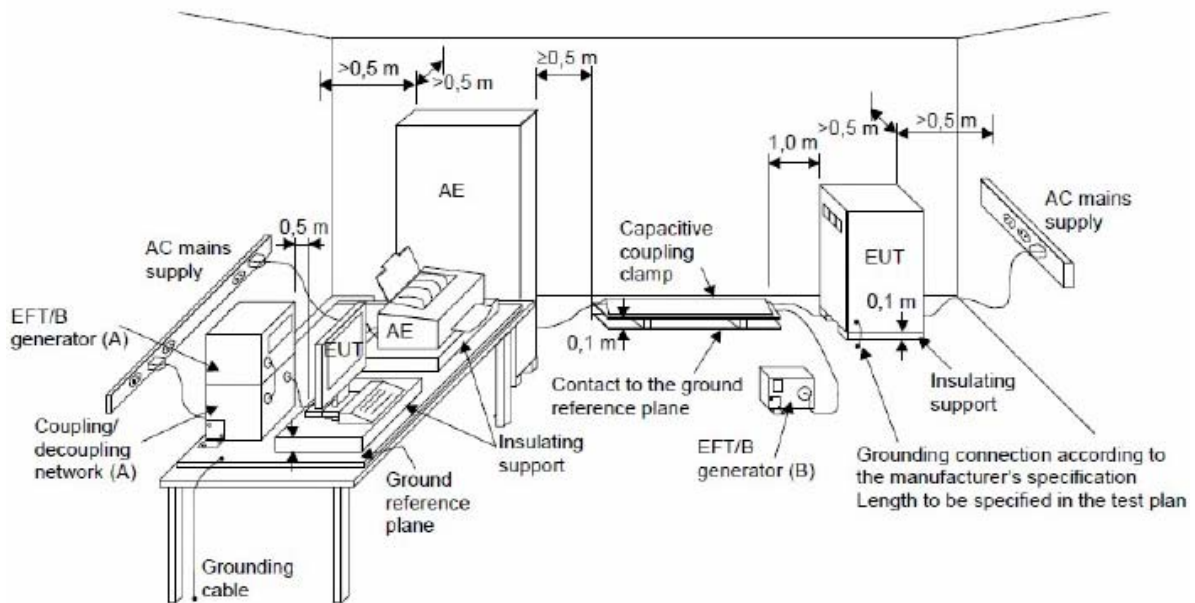
**6.5.5 TEST SETUP**

### 6.5.6 TEST RESULTS

Test Voltage	AC 230V/50Hz
Test Mode	Mode 1 ~ Mode 8

EUT Ports Tested		Polarity	Repetition Frequency	Test Level	Criterion	Result
				1kV		
AC Power Port	Line (L)	+	5 kHz	A	B	A
		-	5 kHz	A		
	Neutral (N)	+	5 kHz	A	B	A
		-	5 kHz	A		
	Ground (PE)	+	5 kHz	A	B	A
		-	5 kHz	A		
	L+N	+	5 kHz	A	B	A
		-	5 kHz	A		
	L+PE	+	5 kHz	A	B	A
		-	5 kHz	A		
	N+PE	+	5 kHz	A	B	A
		-	5 kHz	A		
	L+N+PE	+	5 kHz	A	B	A
		-	5 kHz	A		

## 6.6 SURGE IMMUNITY TEST

### 6.6.1 TEST SPECIFICATION

Basic Standard	EN 61000-4-5
Required Performance	B
Wave-Shape	Combination Wave for power lines 1.2/50 us Open Circuit Voltage 8 /20 us Short Circuit Current
Test Voltage	Power Line: $\pm 0.5$ kV, $\pm 1$ kV, $\pm 2$ kV
Surge Input/Output	L-N, L-PE, N-PE
Generator Source Impedance	2 $\Omega$ of the low-voltage power supply network. 12 $\Omega$ (10 $\Omega$ +2 $\Omega$ ) of the low-voltage power supply network and ground.
Number of Tests & Polarity	5 positive and 5 negative at selected points
Phase Angle	AC Power Port: 0°/90°/180°/270°
Pulse Repetition Rate	1 time / min.

### 6.6.2 MEASUREMENT INSTRUMENTS

Item	Kind of Equipment	Manufacturer	Type No.	Serial No.	Calibrated until
1	THE MODULAR SOLUTION FOR 6 KV APPLICATIONS	Teseq	NSG 3060	1423	Aug. 10, 2020

Remark: "N/A" denotes no model name, no serial No. or no calibration specified.

All calibration period of equipment list is one year.

### 6.6.3 TEST PROCEDURE

a. For EUT power supply:

The surge is to be applied to the EUT power supply terminals via the capacitive coupling network. Decoupling networks are required in order to avoid possible adverse effects on equipment not under test that may be powered by the same lines, and to provide sufficient decoupling impedance to the surge wave. The power cord between the EUT and the coupling/decoupling networks shall be 2meters in length (or shorter).

b. For test applied to unshielded unsymmetrically operated interconnection lines of EUT :

The surge is applied to the lines via the capacitive coupling. The coupling /decoupling networks shall not influence the specified functional conditions of the EUT. The interconnection line between the EUT and the coupling/decoupling networks shall be 2 meters in length (or shorter).

c. For test applied to unshielded symmetrically operated interconnection /telecommunication lines of EUT :

The surge is applied to the lines via gas arrestors coupling. Test levels below the ignition point of the coupling arrester cannot be specified. The interconnection line between the EUT and the coupling/decoupling networks shall be 2 meters in length (or shorter).

**6.6.4 DEVIATION FROM TEST STANDARD**

No deviation

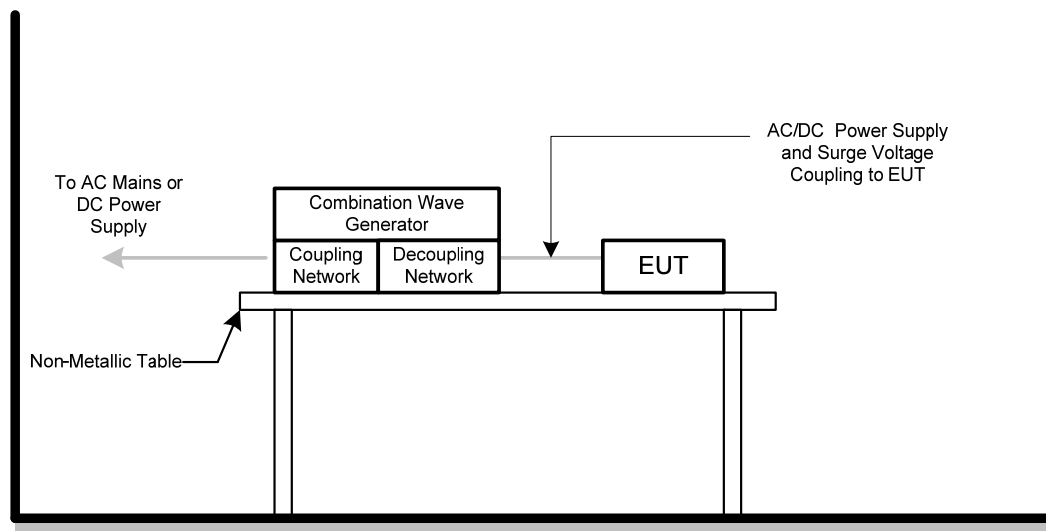
**6.6.5 TEST SETUP**

**6.6.6 TEST RESULTS**

Test Voltage	AC 230V/50Hz
Test Mode	Mode 1 ~ Mode 8

Wave Form EUT Ports Tested		1.2/50(8/20)Tr/Th $\mu$ s						Criterion	Result
		Polarity	Phase	Voltage					
				0.5kV	1kV	-- kV	-- kV		
AC	L – N	+/-	0°	A	A	-	-	B	A
		+/-	90°	A	A	-	-		
		+/-	180°	A	A	-	-		
		+/-	270°	A	A	-	-		

Wave Form EUT Ports Tested		1.2/50(8/20)Tr/Th $\mu$ s						Criterion	Result
		Polarity	Phase	Voltage					
				0.5kV	1kV	2kV	-- kV		
AC	L – PE	+/-	0°	A	A	A	-	B	A
		+/-	90°	A	A	A	-		
		+/-	180°	A	A	A	-		
		+/-	270°	A	A	A	-		
	N – PE	+/-	0°	A	A	A	-	B	A
		+/-	90°	A	A	A	-		
		+/-	180°	A	A	A	-		
		+/-	270°	A	A	A	-		

## 6.7 IMMUNITY TO CONDUCTED DISTURBANCES, INDUCED BY RADIO-FREQUENCY FIELDS TEST (CS)

### 6.7.1 TEST SPECIFICATION

Basic Standard	EN 61000-4-6
Required Performance	A
Frequency Range	0.15 MHz - 80 MHz
Field Strength	3 V (unmodulated, r.m.s.)
Modulation	1 kHz Sine Wave, 80%, AM Modulation
Frequency Step	1% of fundamental
Dwell Time	3 seconds

### 6.7.2 MEASUREMENT INSTRUMENTS

Item	Kind of Equipment	Manufacturer	Type No.	Serial No.	Calibrated until
1	Power CDN	FCC	FCC-801-M2 /M3-16A	100270	Feb. 28, 2021
2	TEST SYSTEM FOR CONDUCTED AND RADIATED IMMUNITY	TESEQ	NSG 4070B	37513	Aug. 03, 2020
3	Measurement Software	Farad	EZ-CS (V2.0.1.4)	N/A	N/A

Remark: "N/A" denotes no model name, no serial No. or no calibration specified.

All calibration period of equipment list is one year.

### 6.7.3 TEST PROCEDURE

The equipment to be tested is placed on an insulating support of 0.1m height above a reference ground plane. All cables exiting the EUT shall be supported at a height of at least 30 mm above the reference ground plane. All relevant cables shall be provided with the appropriate coupling and decoupling devices at a distance between 0.1 meters and 0.3 meters from the projected geometry of the EUT on the ground reference plane.

The other condition as following manner:

- a. The field strength level was 3 V (unmodulated, r.m.s.)
- b. The frequency range is swept from 150 kHz to 80 MHz, with the signal 80% amplitude modulated with a 1 kHz sine wave. Where the frequency range is swept incrementally, the step size was 1% of fundamental.
- c. The dwell time at each frequency shall be not less than the time necessary for the EUT to be able to respond.

### 6.7.4 DEVIATION FROM TEST STANDARD

No deviation

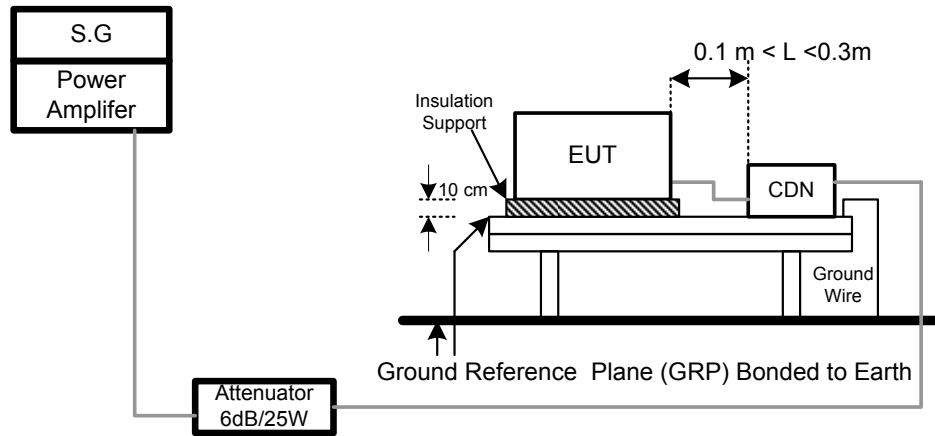

**6.7.5 TEST SETUP**

**6.7.6 TEST RESULTS**

Test Voltage	AC 230V/50Hz
Test Mode	Mode 1 ~ Mode 8

Test Ports (Mode)	Frequency Range (MHz)	Field Strength	Modulation	Criteria	Results
Input/ Output AC.Power Port	0.15 ---80	3V	AM Modulated 1000Hz, 80%	A	A

## 6.8 POWER FREQUENCY MAGNETIC FIELD IMMUNITY TEST (PFMF)

### 6.8.1 TEST SPECIFICATION

Basic Standard	EN 61000-4-8
Required Performance	A
Frequency Range	50/60 Hz
Field Strength	1 A/m
Observation Time	1 minute
Inductance Coil	Rectangular type, 1mx1m

### 6.8.2 MEASUREMENT INSTRUMENTS

Item	Kind of Equipment	Manufacturer	Type No.	Serial No.	Calibrated until
1	Magnetic Field test Generator	FCC	F-1000-4-8-G-125A	4032	Mar. 01, 2021
2	Magnetic Field immunity loop	Thermo KeyTek	F-1000-4-8/9/10-L-1M	4024	Mar. 01, 2021

Remark: "N/A" denotes no model name, no serial No. or no calibration specified.

All calibration period of equipment list is one year.

### 6.8.3 TEST PROCEDURE

For TABLE-TOP equipment:

The equipment shall be subjected to the test magnetic field by using the induction coil of standard dimension (1 m x 1 m). The induction coil shall then be rotated by 90 degrees in order to expose the EUT to the test field with different orientations.

- a. The equipment cabinets shall be connected to the safety earth directly on the GRP via the earth terminal of the EUT.
- b. The cables supplied or recommended by the equipment manufacturer shall be used. 1 meter of all cables used shall be exposed to the magnetic field.

### 6.8.4 DEVIATION FROM TEST STANDARD

No deviation

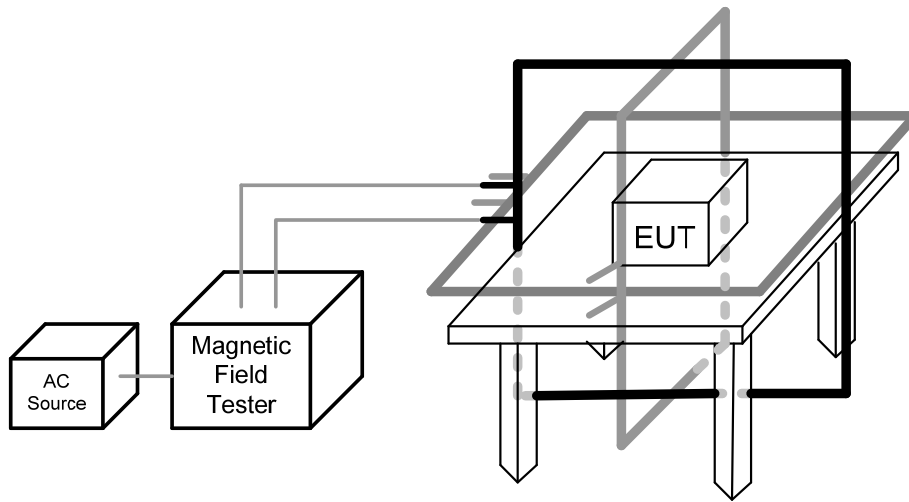
**6.8.5 TEST SETUP**

### 6.8.6 TEST RESULTS

Test Voltage	AC 230V/50Hz
Test Mode	Mode 1 ~ Mode 8

#### 50Hz

Test Mode	Test Level	Antenna aspect	Duration (s)	Criteria	Results
Enclosure	1 A/m	X	60	A	A
Enclosure	1 A/m	Y	60	A	A
Enclosure	1 A/m	Z	60	A	A

#### 60Hz

Test Mode	Test Level	Antenna aspect	Duration (s)	Criteria	Results
Enclosure	1 A/m	X	60	A	A
Enclosure	1 A/m	Y	60	A	A
Enclosure	1 A/m	Z	60	A	A

## 6.9 VOLTAGE DIPS, SHORT INTERRUPTIONS AND VOLTAGE VARIATIONS IMMUNITY TEST

### 6.9.1 TEST SPECIFICATION

Basic Standard	IEC 61000-4-11
Required Performance	B (For >95% Voltage Dips) C (For 30% Voltage Dips) C (For >95% Voltage Interruptions)
Interval between Event	Ten seconds
Phase Angle	0°/180°
Test Cycle	3 times

### 6.9.2 MEASUREMENT INSTRUMENTS

Item	Kind of Equipment	Manufacturer	Type No.	Serial No.	Calibrated until
1	THE MODULAR SOLUTION FOR 6 KV APPLICATIONS	Teseq	NSG 3060	1423	Aug. 10, 2020

Remark: "N/A" denotes no model name, no serial No. or no calibration specified.

All calibration period of equipment list is one year.

### 6.9.3 TEST PROCEDURE

The EUT shall be tested for each selected combination of test levels and duration with a sequence of three dips/interruptions with intervals of 10 s minimum (between each test event). Each representative mode of operation shall be tested. Abrupt changes in supply voltage shall occur at zero crossings of the voltage waveform.

### 6.9.4 DEVIATION FROM TEST STANDARD

No deviation

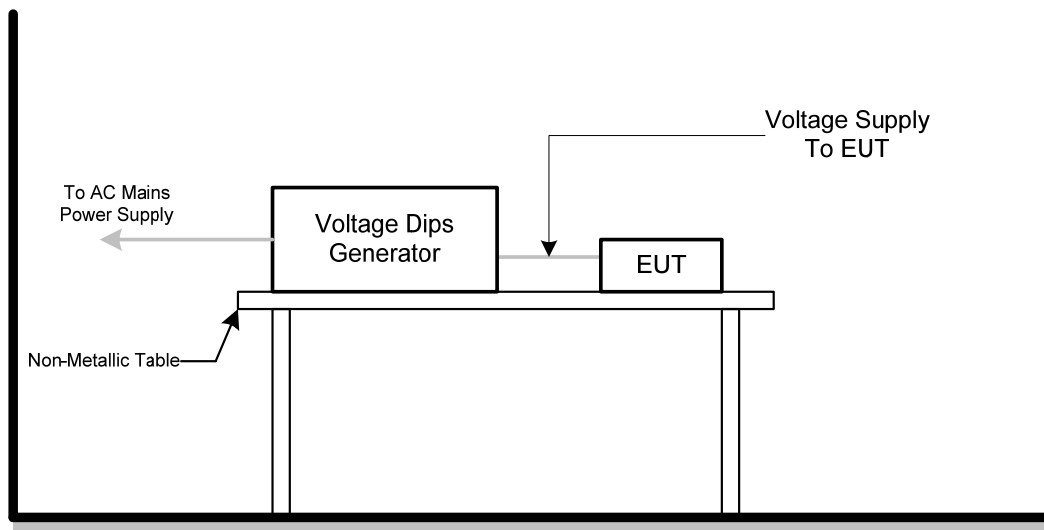
**6.9.5 TEST SETUP**

### 6.9.6 TEST RESULTS

Test Voltage	AC 230V/50Hz
Test Mode	Mode 1 ~ Mode 8

AC 100V/50Hz				
Item	Residual Voltage	Cycle	Criteria	Results
Voltage dips	>95%	0.5	B	A
Voltage dips	30%	25	C	A
Voltage Interruption	>95%	250	C	C

AC 230V/50Hz				
Item	Residual Voltage	Cycle	Criteria	Results
Voltage dips	>95%	0.5	B	A
Voltage dips	30%	25	C	A
Voltage Interruption	>95%	250	C	C

AC 240V/50Hz				
Item	Residual Voltage	Cycle	Criteria	Results
Voltage dips	>95%	0.5	B	A
Voltage dips	30%	25	C	A
Voltage Interruption	>95%	250	C	C



**7. EUT TEST PHOTO**

EN 55032:2012+AC:2013 &amp;2015

Radiated emissions up to 1 GHz

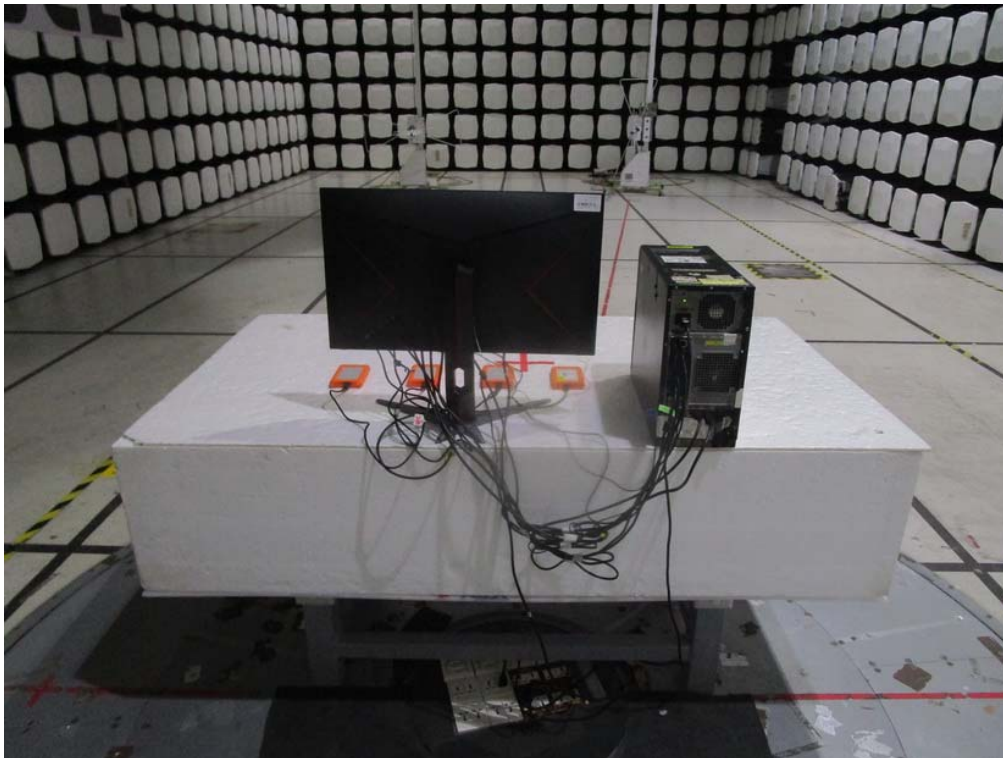
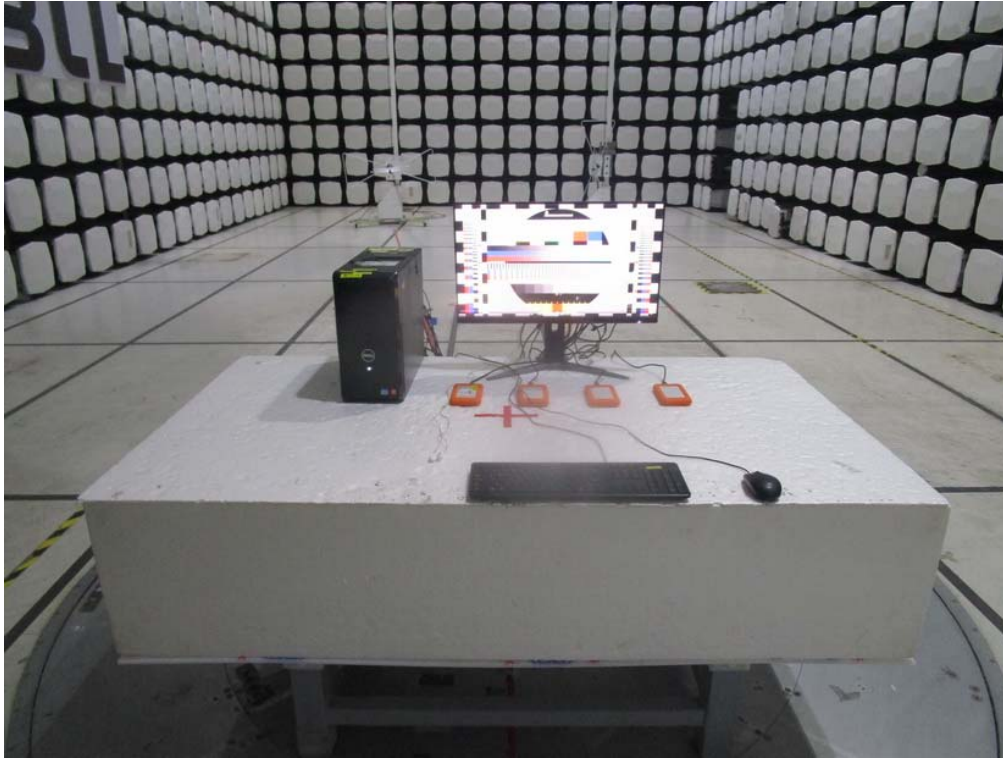

Radiated emissions above 1 GHz

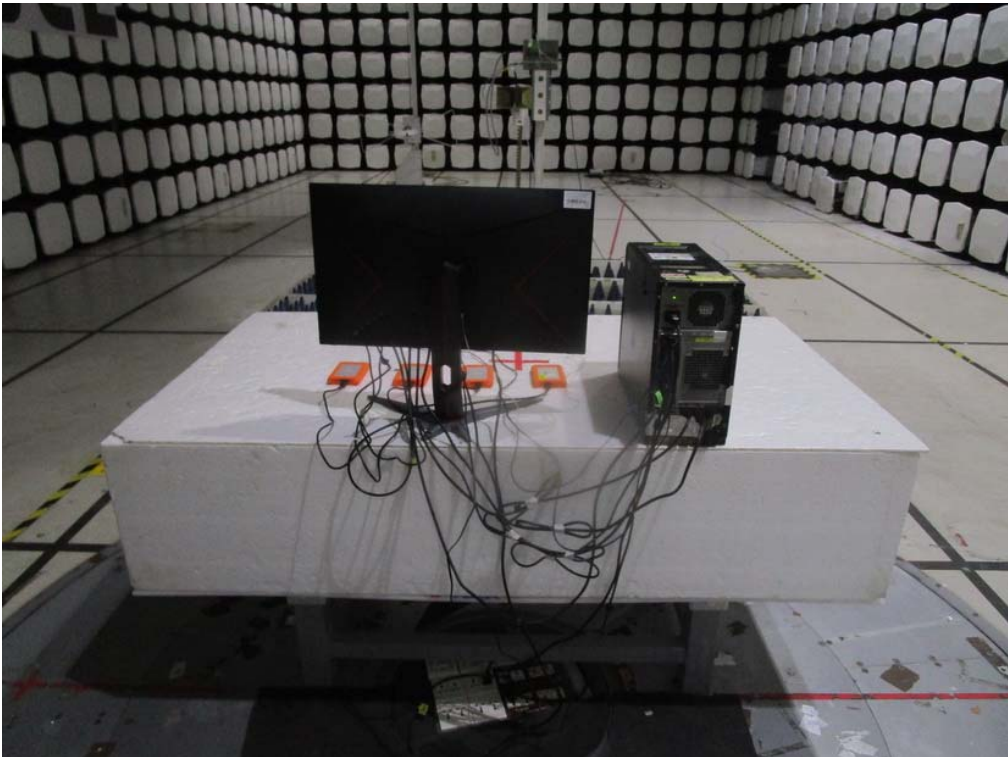
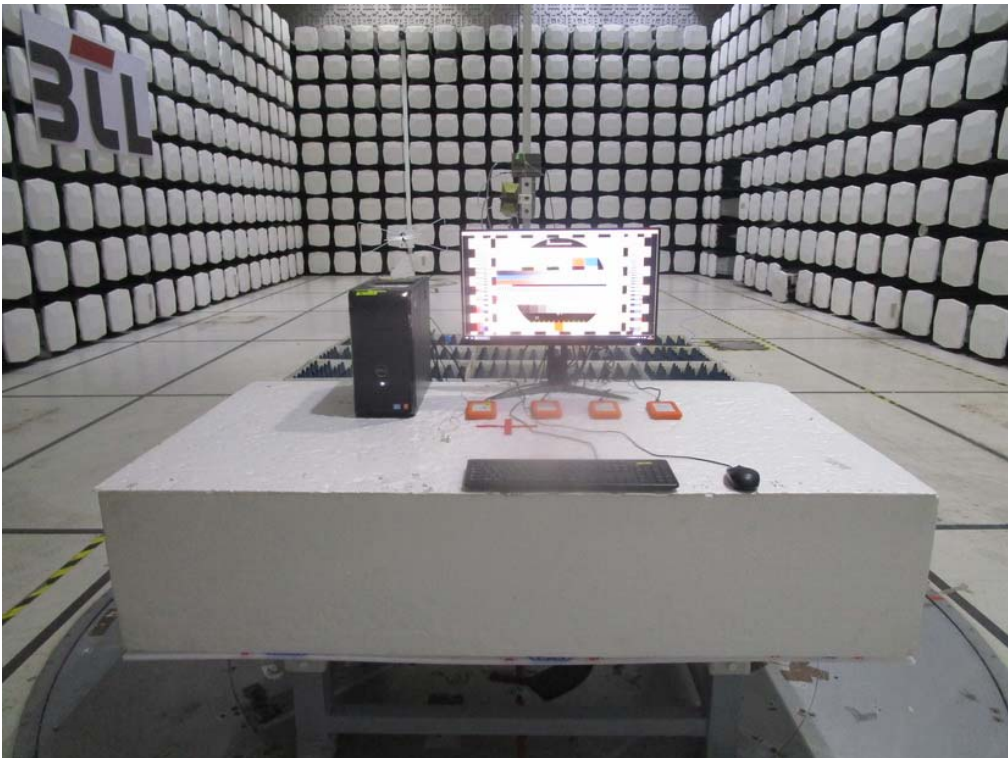

## Conducted emissions AC mains power port



EN 55032:2015+AC:2016

Radiated emissions up to 1 GHz

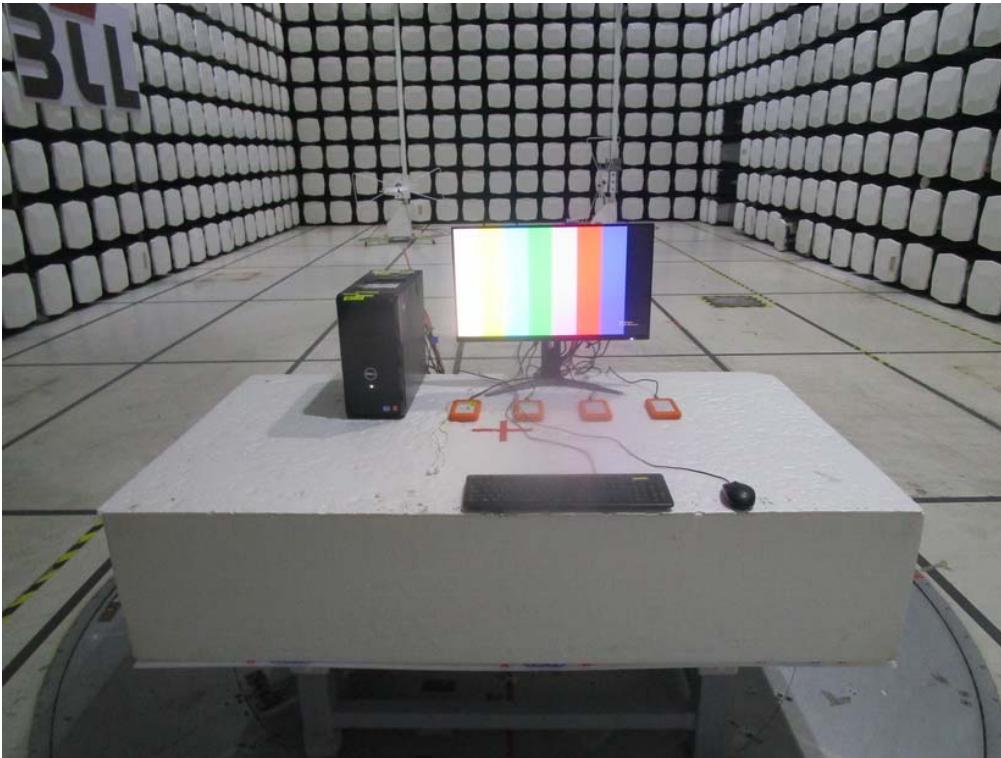

Radiated emissions above 1 GHz

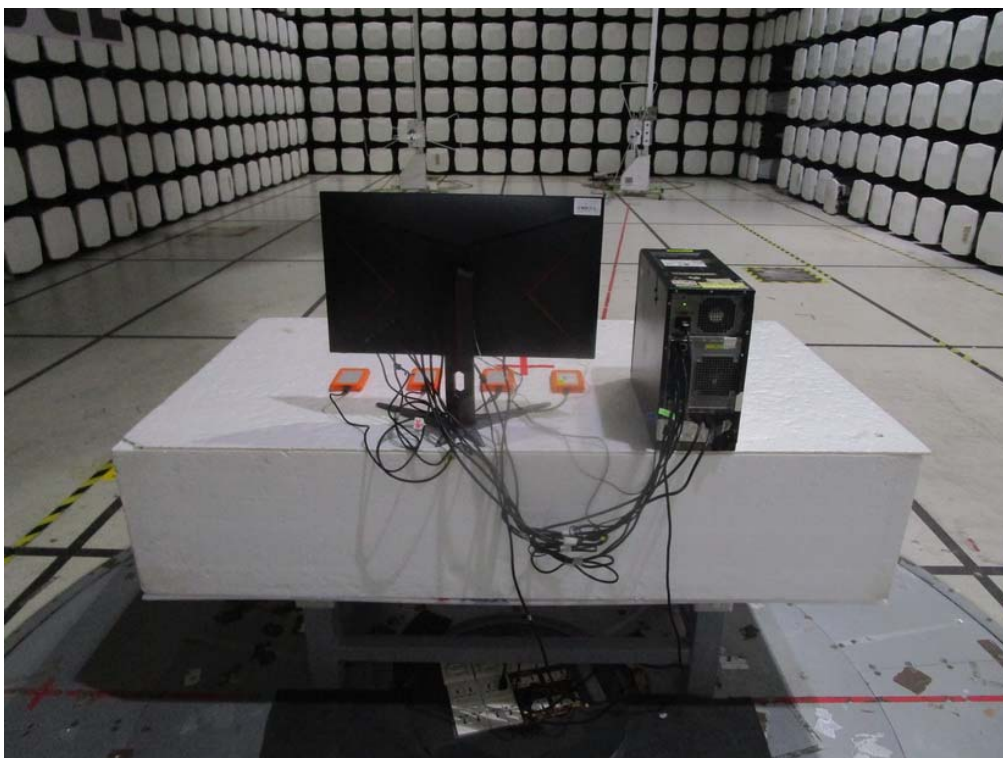
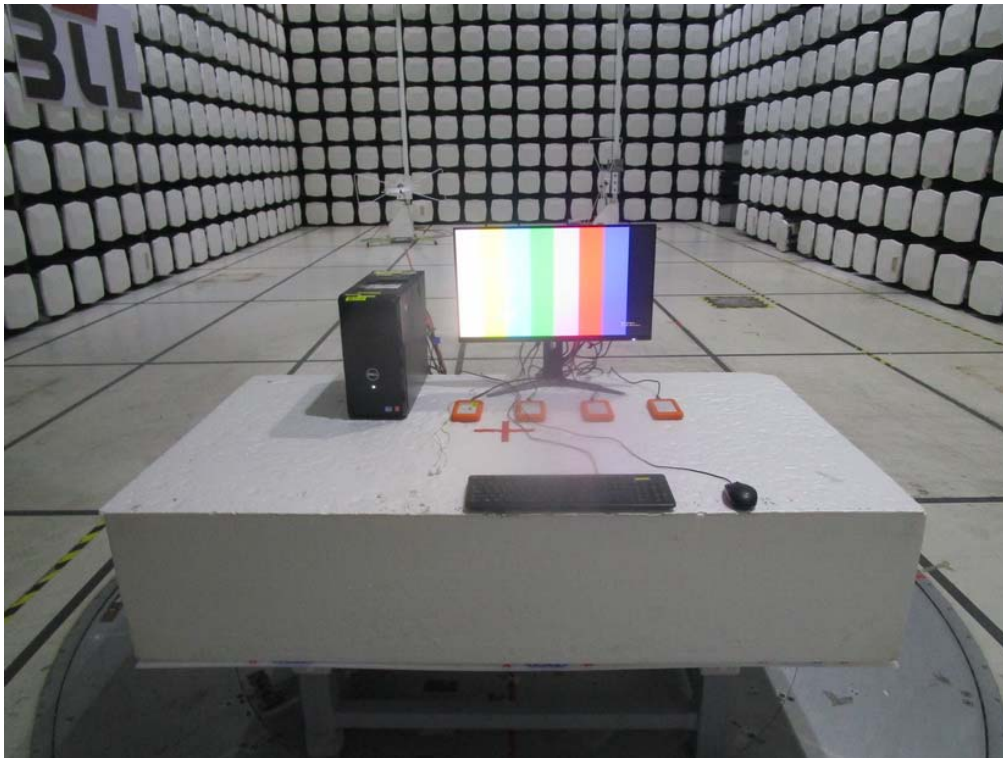

## Conducted emissions AC mains power port



## Harmonic current emissions

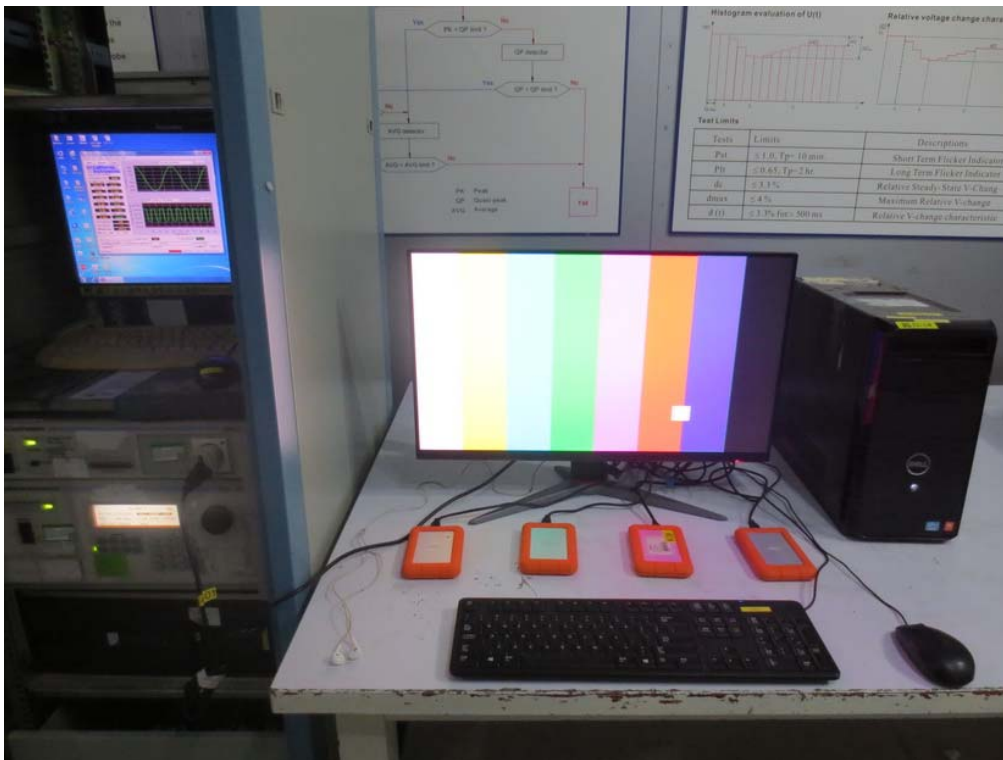

## Voltage changes, voltage fluctuations and flicker

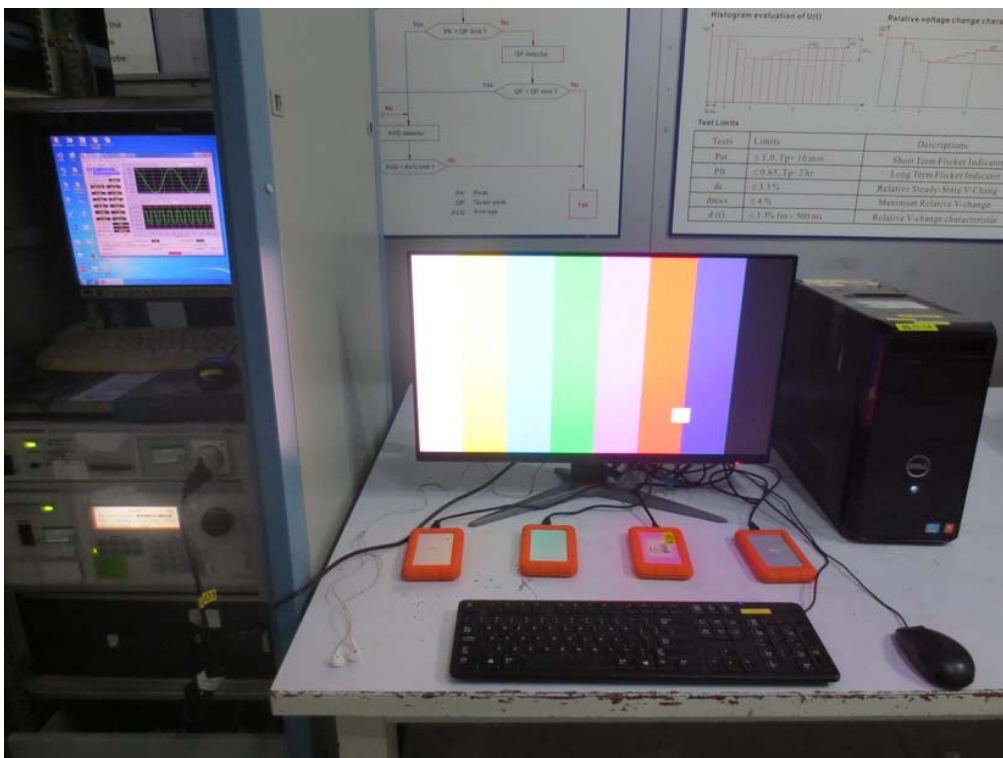

## Electrostatic discharge immunity



## Radiated, radio-frequency, electromagnetic field immunity





Electrical fast transient/burst immunity



Surge immunity



## Immunity to conducted disturbances, induced by radio-frequency fields

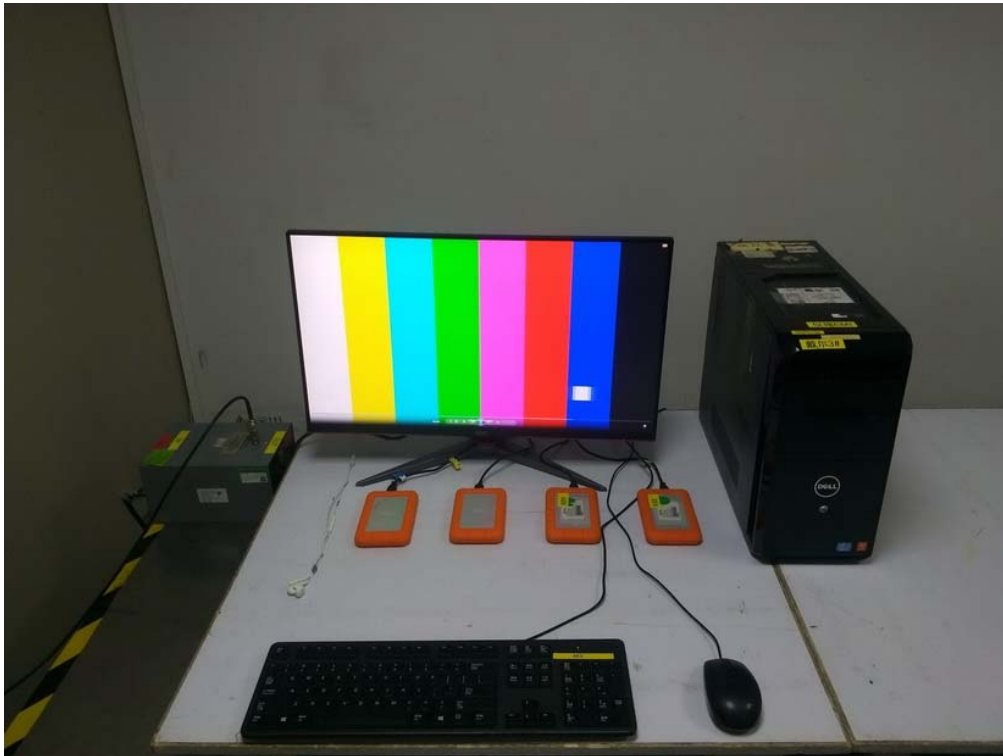

## Power frequency magnetic field immunity



Voltage dips, short interruptions and voltage variations immunity



**End of Test Report**