

CE&UKCA EMC Test Report

Project No. : 2104C082
Equipment : LCD Monitor
Brand Name : N/A
Test Model : **24G2*****(*=0-9,A-Z,a-z,+,-,/, \ or blank)
Series Model : N/A
Applicant : TPV Electronics (Fujian) Co., Ltd.
Address : Rongqiao Economic and Technological Development Zone, Fuqing City, Fujian Province, P.R. China
Date of Receipt : Apr. 13, 2021
Date of Test : Apr. 13, 2021 ~ May 13, 2021
Issued Date : May 28, 2021
Report Version : R00
Test Sample : Engineering Sample No.: DG202104131
Standard(s) : EN 55032:2015 / AS/NZS CISPR 32:2015 / CISPR 32:2015, Class B
EN 55032:2015+AC:2016 / CISPR 32:2015+COR1:2016, Class B
EN 55032:2015+A11:2020 / AS/NZS CISPR 32:2020, Class B
EN 55035:2017/ CISPR 35:2016
EN 55035:2017+A11:2020
IEC 61000-3-2:2014 / EN 61000-3-2:2014, Class D
IEC 61000-3-2:2018 / EN IEC 61000-3-2:2019, Class D
IEC 61000-3-3:2013 / EN 61000-3-3:2013
IEC 61000-3-3:2013+A1:2017 / EN 61000-3-3:2013+A1:2019

BS EN 55032:2015+A11:2020, Class B
BS EN IEC 61000-3-2:2019, Class D
BS EN 61000-3-3:2013+A1:2019
BS EN 55035:2017+A11:2020

The above equipment has been tested and found compliance with the requirement of the relative standards by BTL Inc.

Derek Tong

Prepared by : Derek Tong

Kevin Li

Approved by : Kevin Li



Certificate #5123.02

Add: No.3, Jinshagang 1st Road, Shixia, Dalang Town, Dongguan, Guangdong, China.

Tel: +86-769-8318-3000

Web: www.newbtl.com

Declaration

BTL represents to the client that testing is done in accordance with standard procedures as applicable and that test instruments used has been calibrated with standards traceable to international standard(s) and/or national standard(s).

BTL's reports apply only to the specific samples tested under conditions. It is manufacture's responsibility to ensure that additional production units of this model are manufactured with the identical electrical and mechanical components. **BTL** shall have no liability for any declarations, inferences or generalizations drawn by the client or others from **BTL** issued reports.

The report must not be used by the client to claim product certification, approval, or endorsement by NVLAP, NIST, A2LA, or any agency of the U.S. Government.

This report is the confidential property of the client. As a mutual protection to the clients, the public and ourselves, the test report shall not be reproduced, except in full, without our written approval.

BTL's laboratory quality assurance procedures are in compliance with the **ISO/IEC 17025** requirements, and accredited by the conformity assessment authorities listed in this test report.

BTL is not responsible for the sampling stage, so the results only apply to the sample as received.

The information, data and test plan are provided by manufacturer which may affect the validity of results, so it is manufacturer's responsibility to ensure that the apparatus meets the essential requirements of applied standards and in all the possible configurations as representative of its intended use.

Limitation

For the use of the authority's logo is limited unless the Test Standard(s)/Scope(s)/Item(s) mentioned in this test report is (are) included in the conformity assessment authorities acceptance respective.

Please note that the measurement uncertainty is provided for informational purpose only and are not use in determining the Pass/Fail results.

| Table of Contents | Page |
|--|-------------|
| REPORT ISSUED HISTORY | 7 |
| 1 . SUMMARY OF TEST RESULTS | 8 |
| 1.1 TEST FACILITY | 10 |
| 1.2 MEASUREMENT UNCERTAINTY | 10 |
| 1.3 TEST ENVIRONMENT CONDITIONS | 12 |
| 2 . GENERAL INFORMATION | 13 |
| 2.1 GENERAL DESCRIPTION OF EUT | 13 |
| 2.2 DESCRIPTION OF TEST MODES | 14 |
| 2.3 EUT OPERATING CONDITIONS | 15 |
| 2.4 BLOCK DIAGRAM SHOWING THE CONFIGURATION OF SYSTEM TESTED | 16 |
| 2.5 DESCRIPTION OF SUPPORT UNITS | 16 |
| 3 . EMC EMISSION TEST- EN55032: 2015 | 18 |
| 3.1 RADIATED EMISSION UP TO 1 GHZ | 18 |
| 3.1.1 LIMITS | 18 |
| 3.1.2 MEASUREMENT INSTRUMENTS LIST | 18 |
| 3.1.3 TEST PROCEDURE | 19 |
| 3.1.4 DEVIATION FROM TEST STANDARD | 19 |
| 3.1.5 TEST SETUP | 19 |
| 3.1.6 MEASUREMENT DISTANCE | 20 |
| 3.1.7 TEST RESULTS (UP TO 1 GHZ) | 21 |
| 3.2 RADIATED EMISSION ABOVE 1 GHZ | 31 |
| 3.2.1 LIMITS | 31 |
| 3.2.2 MEASUREMENT INSTRUMENTS LIST | 31 |
| 3.2.3 TEST PROCEDURE | 32 |
| 3.2.4 DEVIATION FROM TEST STANDARD | 32 |
| 3.2.5 TEST SETUP | 32 |
| 3.2.6 MEASUREMENT DISTANCE | 33 |
| 3.2.7 TEST RESULTS (ABOVE 1 GHZ) | 34 |
| 3.3 CONDUCTED EMISSION MEASUREMENT AT AC MAINS POWER PORTS | 44 |
| 3.3.1 LIMITS | 44 |
| 3.3.2 MEASUREMENT INSTRUMENTS LIST | 44 |
| 3.3.3 TEST PROCEDURE | 44 |
| 3.3.4 DEVIATION FROM TEST STANDARD | 44 |
| 3.3.5 TEST SETUP | 45 |
| 3.3.6 TEST RESULTS | 46 |
| 4 . EMC EMISSION TEST- EN 55032:2015+A11:2020 | 54 |
| 4.1 RADIATED EMISSIONS UP TO 1 GHZ | 54 |

| Table of Contents | Page |
|---|-------------|
| 4.1.1 LIMITS | 54 |
| 4.1.2 MEASUREMENT INSTRUMENTS LIST | 54 |
| 4.1.3 TEST PROCEDURE | 55 |
| 4.1.4 DEVIATION FROM TEST STANDARD | 55 |
| 4.1.5 TEST SETUP | 55 |
| 4.1.6 MEASUREMENT DISTANCE | 56 |
| 4.1.7 TEST RESULTS (UP TO 1 GHZ) | 57 |
| 4.2 RADIATED EMISSIONS ABOVE 1 GHZ | 59 |
| 4.2.1 LIMITS | 59 |
| 4.2.1 MEASUREMENT INSTRUMENTS LIST | 59 |
| 4.2.1.1 TEST PROCEDURE | 60 |
| 4.2.1.2 DEVIATION FROM TEST STANDARD | 60 |
| 4.2.1.3 TEST SETUP | 60 |
| 4.2.1.4 MEASUREMENT DISTANCE | 61 |
| 4.2.1.5 TEST RESULTS (ABOVE 1 GHZ) | 62 |
| 4.3 CONDUCTED EMISSION MEASUREMENT AT AC MAINS POWER PORTS | 64 |
| 4.3.1 LIMITS | 64 |
| 4.3.2 MEASUREMENT INSTRUMENTS LIST | 64 |
| 4.3.3 TEST PROCEDURE | 64 |
| 4.3.4 TEST SETUP | 65 |
| 4.3.5 TEST RESULTS | 66 |
| 5 . HARMONIC AND FLICKER TEST | 68 |
| 5.1 HARMONIC CURRENT EMISSIONS | 68 |
| 5.1.1 LIMITS | 68 |
| 5.1.2 MEASUREMENT INSTRUMENTS LIST | 68 |
| 5.1.3 TEST PROCEDURE | 68 |
| 5.1.4 DEVIATION FROM TEST STANDARD | 68 |
| 5.1.5 TEST SETUP | 68 |
| 5.1.6 TEST RESULTS | 69 |
| 5.2 VOLTAGE CHANGES, VOLTAGE FLUCTUATIONS AND FLICKER TEST | 72 |
| 5.2.1 LIMITS | 72 |
| 5.2.2 MEASUREMENT INSTRUMENTS LIST | 72 |
| 5.2.3 TEST PROCEDURE | 72 |
| 5.2.4 DEVIATION FROM TEST STANDARD | 72 |
| 5.2.5 TEST SETUP | 73 |
| 5.2.6 TEST RESULTS | 74 |
| 6 . EMC IMMUNITY TEST | 75 |
| 6.1 STANDARD COMPLIANCE/SEVERITY LEVEL/CRITERIA | 75 |
| 6.2 GENERAL PERFORMANCE CRITERIA | 78 |
| 6.3 ANNEX D (NORMATIVE) - DISPLAY AND DISPLAY OUTPUT FUNCTION | 79 |
| 6.3.1 PERFORMANCE CRITERIA | 79 |

| Table of Contents | Page |
|--|-------------|
| 6.4 ANNEX G (NORMATIVE) - AUDIO OUTPUT FUNCTION | 80 |
| 6.4.1 PERFORMANCE CRITERIA | 80 |
| 6.5 ELECTROSTATIC DISCHARGE IMMUNITY TEST (ESD) | 81 |
| 6.5.1 TEST SPECIFICATION | 81 |
| 6.5.2 MEASUREMENT INSTRUMENTS | 81 |
| 6.5.3 TEST PROCEDURE | 81 |
| 6.5.4 DEVIATION FROM TEST STANDARD | 82 |
| 6.5.5 TEST SETUP | 82 |
| 6.5.6 TEST RESULTS | 83 |
| 6.6 RADIATED, RADIO-FREQUENCY, ELECTROMAGNETIC FIELD IMMUNITY TEST (RS) | 86 |
| 6.6.1 TEST SPECIFICATION | 86 |
| 6.6.2 MEASUREMENT INSTRUMENTS | 86 |
| 6.6.3 TEST PROCEDURE | 86 |
| 6.6.4 DEVIATION FROM TEST STANDARD | 87 |
| 6.6.5 TEST SETUP | 87 |
| 6.6.6 TEST RESULTS | 89 |
| 6.7 ELECTRICAL FAST TRANSIENT/BURST IMMUNITY TEST (EFT/BURST) | 92 |
| 6.7.1 TEST SPECIFICATION | 92 |
| 6.7.2 MEASUREMENT INSTRUMENTS | 92 |
| 6.7.3 TEST PROCEDURE | 92 |
| 6.7.4 DEVIATION FROM TEST STANDARD | 92 |
| 6.7.5 TEST SETUP | 93 |
| 6.7.6 TEST RESULTS | 94 |
| 6.8 SURGE IMMUNITY TEST | 95 |
| 6.8.1 TEST SPECIFICATION | 95 |
| 6.8.2 MEASUREMENT INSTRUMENTS | 95 |
| 6.8.3 TEST PROCEDURE | 95 |
| 6.8.4 DEVIATION FROM TEST STANDARD | 96 |
| 6.8.5 TEST SETUP | 96 |
| 6.8.6 TEST RESULTS | 97 |
| 6.9 IMMUNITY TO CONDUCTED DISTURBANCES, INDUCED BY RADIO-FREQUENCY FIELDS TEST (CS) | 98 |
| 6.9.1 TEST SPECIFICATION | 98 |
| 6.9.2 MEASUREMENT INSTRUMENTS | 98 |
| 6.9.3 TEST PROCEDURE | 98 |
| 6.9.4 DEVIATION FROM TEST STANDARD | 99 |
| 6.9.5 TEST SETUP | 99 |
| 6.9.6 TEST RESULTS | 101 |
| 6.10 POWER FREQUENCY MAGNETIC FIELD IMMUNITY TEST (PFMF) | 103 |
| 6.10.1 TEST SPECIFICATION | 103 |
| 6.10.2 MEASUREMENT INSTRUMENTS | 103 |
| 6.10.3 TEST PROCEDURE | 103 |

| Table of Contents | Page |
|---|-------------|
| 6.10.4 DEVIATION FROM TEST STANDARD | 103 |
| 6.10.5 TEST SETUP | 104 |
| 6.10.6 TEST RESULTS | 105 |
| 6.11 VOLTAGE DIPS, SHORT INTERRUPTIONS AND VOLTAGE VARIATIONS IMMUNITY | |
| TEST (DIPS) | 106 |
| 6.11.1 TEST SPECIFICATION | 106 |
| 6.11.2 MEASUREMENT INSTRUMENTS | 106 |
| 6.11.3 TEST PROCEDURE | 106 |
| 6.11.4 DEVIATION FROM TEST STANDARD | 106 |
| 6.11.5 TEST SETUP | 106 |
| 6.11.6 TEST RESULTS | 107 |
| 7 . EUT TEST PHOTO | 108 |

REPORT ISSUED HISTORY

| Report Version | Description | Issued Date |
|----------------|-----------------|--------------|
| R00 | Original Issue. | May 28, 2021 |

1. SUMMARY OF TEST RESULTS

Test procedures according to the technical standards:

| Emission | | | |
|--|---|---------------|-----|
| Standard(s) | Test Item | Result | |
| EN 55032:2015 / AS/NZS CISPR 32:2015 / CISPR 32:2015 EN 55032:2015+AC:2016/ CISPR 32:2015+COR1:2016 EN 55032:2015+A11:2020 / AS/NZS CISPR 32:2020 BS EN 55032:2015+A11:2020 | Radiated emissions up to 1 GHz | PASS | |
| | Radiated emissions above 1 GHz | PASS | |
| | Radiated emissions from FM receivers | N/A | |
| | Conducted emissions AC mains power port | PASS | |
| | Asymmetric mode conducted emissions | AAN | N/A |
| | | Current Probe | N/A |
| | | CP+CVP | N/A |
| Conducted differential voltage emissions | N/A | | |

| Standard(s) | Test Item | Result |
|--|--------------------------------|--------|
| IEC 61000-3-2:2014 / EN 61000-3-2:2014 IEC 61000-3-2:2018 / EN IEC 61000-3-2:2019 BS EN IEC 61000-3-2:2019 | Harmonic current | PASS |
| IEC 61000-3-3:2013 / EN 61000-3-3:2013 IEC 61000-3-3:2013+A1:2017 / EN 61000-3-3:2013+A1:2019 BS EN 61000-3-3:2013+A1:2019 | Voltage fluctuations (Flicker) | PASS |

| Immunity | | | |
|---|---|-----------|--------|
| Standard(s) | Ref Standard(s) | Test Item | Result |
| EN 55035:2017/ CISPR 35:2016 EN 55035:2017+A11:2020 BS EN 55035:2017+A11:2020 | IEC 61000-4-2:2008 / EN 61000-4-2:2009 | ESD | PASS |
| | IEC 61000-4-3:2006+A1:2007+A2:2010 EN 61000-4-3:2006+A1:2008+A2:2010 | RS | PASS |
| | IEC 61000-4-4:2012 / EN 61000-4-4:2012 | EFT | PASS |
| | IEC 61000-4-5:2014+A1:2017 EN 61000-4-5:2014+A1:2017 | Surge | PASS |
| | IEC 61000-4-6:2013 EN 61000-4-6:2014+AC:2015 | CS | PASS |
| | IEC 61000-4-8:2009 / EN 61000-4-8:2010 | PFMF | PASS |
| | IEC 61000-4-11:2004+A1:2017 EN 61000-4-11:2004+A1:2017 | Dips | PASS |

| | | | |
|---|-------|---|-----|
| EN 55035:2017/ CISPR 35:2016 EN 55035:2017+A11:2020 BS EN 55035:2017+A11:2020 | 4.2.7 | Broadband impulse noise disturbances, repetitive | N/A |
| | 4.2.7 | Broadband impulse noise disturbances, isolated | N/A |

NOTE:

(1) "N/A" denotes test is not applicable to this device.

1.1 TEST FACILITY

The test facilities used to collect the test data in this report is at the location of No.3, Jinshagang 1st Road, Shixia, Dalang Town, Dongguan, Guangdong, China.

1.2 MEASUREMENT UNCERTAINTY

Where relevant, the following measurement uncertainty levels have been estimated for tests performed on the EUT as specified in CISPR 16-4-2, The BTL measurement uncertainty is less than the CISPR 16-4-2 U_{CISPR} requirement.

The reported uncertainty of measurement $y \pm U$, where expanded uncertainty U is based on a standard uncertainty multiplied by a coverage factor of $k=2$, providing a level of confidence of approximately 95%.

A. Radiated emissions up to 1 GHz measurement:

| Test Site | Method | Measurement Frequency Range | Ant. H / V | U,(dB) |
|------------------|--------|-----------------------------|------------|--------|
| DG-CB08 (10m) | CISPR | 30MHz ~ 200MHz | V | 4.44 |
| | | 30MHz ~ 200MHz | H | 3.44 |
| | | 200MHz ~ 1,000MHz | V | 4.28 |
| | | 200MHz ~ 1,000MHz | H | 3.52 |

B. Radiated emissions above 1 GHz measurement:

| Test Site | Method | Measurement Frequency Range | U,(dB) |
|-----------------|--------|-----------------------------|--------|
| DG-CB08 (3m) | CISPR | 1GHz ~ 6GHz | 4.36 |

C. Conducted emissions AC mains power port measurement:

| Test Site | Method | Measurement Frequency Range | U,(dB) |
|-----------|--------|-----------------------------|--------|
| DG-C01 | CISPR | 150kHz ~ 30MHz | 3.18 |

D. Harmonic/ Flicker Measurement:

| Test Site | Method | Item | U (%) |
|-----------|--------------|---------|-------|
| DG-C01 | EN 61000-3-2 | Current | 0.593 |
| | EN 61000-3-3 | Voltage | 0.595 |

E. Immunity Measurement:

| Test Site | Method | Item | U |
|-----------|---------------------------------|---|--------|
| DG-SR02 | IEC 61000-4-2 | Rise time t_r | 6.80% |
| | | Peak current I_p | 6.30% |
| | | Current at 30 ns | 6.50% |
| | | Current at 60 ns | 6.90% |
| DG-CB05 | IEC 61000-4-3 (80MHz~6GHz) | Electromagnetic field immunity test | 2.38dB |
| | | On-ear acoustic & Acoustic measurements on loudspeakers | 2.40dB |
| | | Electrical measurements | 2.40dB |
| DG-SR05 | IEC 61000-4-4 | Peak voltage (V_p) | 3.7% |
| | | Rise time (t_r) | 4.4% |
| | | Pulse width(t_w) | 4.1% |
| | | Pulse Freq.(kHz) | 0.8% |
| | | Burst Duration(ms) | 1.4% |
| | | Burst Period(ms) | 1.4% |
| DG-SR05 | IEC 61000-4-5 | Open-Circuit Output Voltage (1.2/50us) | 3.8% |
| | | Open circuit front time (1.2/50us) | 6.3% |
| | | Open circuit time of half value (1.2/50us) | 4.6% |
| DG-CB06 | IEC 61000-4-6 (150kHz-80MHz) | CDN | 1.32dB |
| | | EM clamp | 3.16dB |
| | | On-ear acoustic & Acoustic measurements on loudspeakers | 1.36dB |
| | | Electrical measurements | 1.34dB |
| DG-SR05 | IEC 61000-4-8 | Magnetic Field Strength | 2.38% |
| DG-SR05 | IEC 61000-4-11 | DIP Amplitude | 0.5% |
| | | DIP Time Event | 3% |

Note: Unless specifically mentioned, the uncertainty of measurement has not been taken into account to declare the compliance or non-compliance to the specification.

1.3 TEST ENVIRONMENT CONDITIONS

| Test Item | Temperature | Humidity | Tested By |
|--|-------------|----------|-----------|
| Radiated emissions up to 1 GHz | 25°C | 60% | Kay Zhu |
| Radiated emissions above 1 GHz | 25°C | 60% | Kay Zhu |
| Conducted emissions AC mains power port | 25°C | 53% | Jayce Yao |
| Harmonic current | 25°C | 55% | Jayce Yao |
| Voltage fluctuations (Flicker) | 25°C | 55% | Jayce Yao |

| Test Item | Temperature | Humidity | Pressure | Tested By |
|-----------|-------------|----------|----------|------------|
| ESD | 22°C | 45% | 1010hPa | Rich Ye |
| RS | 22°C | 50% | / | Hunter Xu |
| EFT | 22°C | 50% | / | Celina Lai |
| Surge | 22°C | 50% | / | Celina Lai |
| CS | 22°C | 50% | / | Daniel Li |
| PFMF | 22°C | 50% | / | Daniel Li |
| Dips | 22°C | 50% | / | Daniel Li |

2. GENERAL INFORMATION

2.1 GENERAL DESCRIPTION OF EUT

| | |
|--------------------------------|---|
| Equipment | LCD Monitor |
| Brand Name | N/A |
| Test Model | **24G2*****(*=0-9,A-Z,a-z,+,-,/,\ or blank) |
| Series Model | N/A |
| Model Difference(s) | Only differ in model name due to marketing purpose |
| Power Source | AC Mains. |
| Power Rating | 100-240V~50-60Hz 1.3A |
| Connecting I/O Port(s) | 1* AC port 1* D-SUB port 2* HDMI port 1* DP port 5* USB port 1* Earphone port 1* Audio port |
| Classification Of EUT | Class B |
| Highest Internal Frequency(Fx) | 571MHz |

| Cable Type | Shielded Type | Ferrite Core | Length(m) | Note |
|---------------|---------------|--------------|-------------|----------------------------------|
| AC Power Cord | Non-shielded | NO | 1.8/1.5/1.2 | 1.8m is worst case Detachable |
| HDMI | Shielded | NO | 1.8/1.5/1.2 | - |
| D-SUB | Shielded | YES | 1.8/1.5/1.2 | Bonded two Ferrite Cores |
| DP | Shielded | NO | 1.8/1.5/1.2 | - |
| USB | Shielded | NO | 1.8/1.5/1.2 | - |
| Audio | Non-shielded | NO | 1.8/1.5/1.2 | - |

Note:

- For a more detailed features description, please refer to the manufacturer's specifications or the user's manual.
- Power cable 1.8m, 1.5m, 1.2m length, worst case is Power cable 1.8m with HDMI+D-SUB+DP+Audio+USB length testing and recording in test report.

2.2 DESCRIPTION OF TEST MODES

To investigate the maximum EMI emission characteristics generates from EUT, the test system was pre-scanning tested base on the consideration of following EUT operation mode or test configuration mode which possible have effect on EMI emission level. Each of these EUT operation mode(s) or test configuration mode(s) mentioned above was evaluated respectively.

| Pretest Mode | Description |
|--------------|--|
| Mode 1 | HDMI 1 1920*1080/144Hz 1.8m H |
| Mode 2 | HDMI 2 1920*1080/144Hz 1.8m H |
| Mode 3 | DP 1920*1080/160Hz 1.8m H |
| Mode 4 | D-SUB 1920*1080/60Hz 1.8m H |
| Mode 5 | HDMI1 1080P 1.8m H |
| Mode 6 | HDMI2 1080P 1.8m H |
| Mode 7 | HDMI 1 1280*1024/60Hz 1.8m H |
| Mode 8 | HDMI 1 640*480/60Hz 1.8m H |
| Mode 9 | HDMI 1 1920*1080/144Hz 1.5m H |
| Mode 10 | HDMI 1 1920*1080/144Hz 1.2m H |
| Mode 11 | HDMI 1 1920*1080/144Hz without earphone 1.8m H |
| Mode 12 | HDMI 1 1920*1080/144Hz 1.8m V |

| Radiated emissions up to 1 GHz test | |
|-------------------------------------|--|
| Final Test Mode | Description |
| Mode 1 | HDMI 1 1920*1080/144Hz 1.8m H |
| Mode 2 | HDMI 2 1920*1080/144Hz 1.8m H |
| Mode 5 | HDMI1 1080P 1.8m H |
| Mode 11 | HDMI 1 1920*1080/144Hz without earphone 1.8m H |

| Radiated emissions Above 1 GHz test | |
|-------------------------------------|--|
| Final Test Mode | Description |
| Mode 1 | HDMI 1 1920*1080/144Hz 1.8m H |
| Mode 2 | HDMI 2 1920*1080/144Hz 1.8m H |
| Mode 5 | HDMI1 1080P 1.8m H |
| Mode 11 | HDMI 1 1920*1080/144Hz without earphone 1.8m H |

| Conducted emissions AC mains power port test | |
|--|-------------------------------|
| Final Test Mode | Description |
| Mode 1 | HDMI 1 1920*1080/144Hz 1.8m H |
| Mode 2 | HDMI 2 1920*1080/144Hz 1.8m H |
| Mode 5 | HDMI1 1080P 1.8m H |

| Harmonic current & Voltage fluctuations (Flicker) Test | |
|--|-------------------------------|
| Final Test Mode | Description |
| Mode 1 | HDMI 1 1920*1080/144Hz 1.8m H |

| Immunity Test | |
|-----------------|-------------------------------|
| Final Test Mode | Description |
| Mode 1 | HDMI 1 1920*1080/144Hz 1.8m H |
| Mode 2 | HDMI 2 1920*1080/144Hz 1.8m H |
| Mode 3 | DP 1920*1080/160Hz 1.8m H |
| Mode 4 | D-SUB 1920*1080/60 1.8m H |
| Mode 5 | HDMI1 1080P 1.8m H |
| Mode 6 | HDMI2 1080P 1.8m H |
| Mode 9 | HDMI 1 1920*1080/144Hz 1.5m H |
| Mode 10 | HDMI 1 1920*1080/144Hz 1.2m H |

Evaluation description:

1. The maximum resolution is evaluated Mode 1-6. The worst case is Mode 1 and evaluated the middle and low resolution Mode 7 and Mode 8.
2. According to the client's requirement, choose Mode 1, Mode 2, Mode 5 and recorded in test report.
3. RS Acoustic: The Front, Rear, Left and Right were evaluated. The worst placement direction is Front and recorded in this report.

2.3 EUT OPERATING CONDITIONS

The EUT exercise program used during radiated and/or conducted emission measurement was designed to exercise the various system components in a manner similar to a typical use. The standard test signals and output signal as following:

1. EUT connected to PC via HDMI&D-SUB&DP&USB&Audio cable.
2. EUT connected to Earphone via Earphone cable.
3. EUT connected to USB3.0 Hard Disk via USB cable.
4. Mouse and Keyboard connected to PC via USB cable.

2.4 BLOCK DIAGRAM SHOWING THE CONFIGURATION OF SYSTEM TESTED

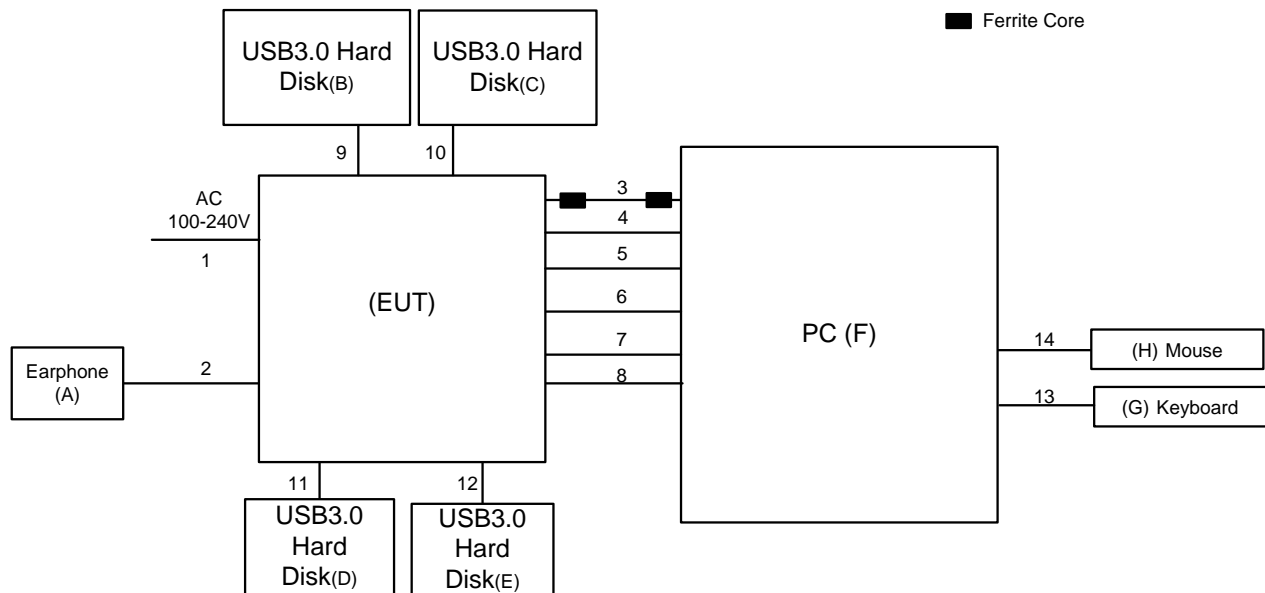

2.5 DESCRIPTION OF SUPPORT UNITS

The EUT has been tested as an independent unit together with other necessary accessories or support units. The following support units or accessories were used to form a representative test configuration during the tests.

| Item | Equipment | Mfr/Brand | Model/Type No. | Series No. |
|------|------------------|-----------|------------------|-------------------------|
| A | Earphone | APPLE | N/A | N/A |
| B | USB3.0 Hard Disk | LACIE | Lacie S.A series | NL34BJSM |
| C | USB3.0 Hard Disk | LACIE | Lacie S.A series | NL33PVLS |
| D | USB3.0 Hard Disk | LACIE | Lacie S.A series | NL34BJRF |
| E | USB3.0 Hard Disk | LACIE | Lacie S.A series | NL33PVK4 |
| F | PC | DELL | Vostro 470 | 24454162837 |
| G | Keyboard | DELL | KB212-B | CN0HTXH97158125004DXA01 |
| H | Mouse | Lenovo | M-SBF96 | N/A |

| Item | Cable Type | Shielded Type | Ferrite Core | Length |
|------|-------------|---------------|--------------|--------------|
| 1 | AC Cable | NO | NO | 1.8/1.5/1.2m |
| 2 | Earphone | NO | NO | 1.2m |
| 3 | D-SUB Cable | YES | YES | 1.8/1.5/1.2m |
| 4 | HDMI Cable | YES | NO | 1.8/1.5/1.2m |
| 5 | HDMI Cable | YES | NO | 1.8/1.5/1.2m |
| 6 | DP Cable | YES | NO | 1.8/1.5/1.2m |
| 7 | USB Cable | YES | NO | 1.8/1.5/1.2m |
| 8 | AUDIO Cable | NO | NO | 1.8/1.5/1.2m |
| 9 | USB Cable | YES | NO | 1m |
| 10 | USB Cable | YES | NO | 1m |
| 11 | USB Cable | YES | NO | 1m |
| 12 | USB Cable | YES | NO | 1m |
| 13 | USB Cable | YES | NO | 1.8m |
| 14 | USB Cable | YES | NO | 1.8m |

3. EMC EMISSION TEST- EN55032: 2015

3.1 RADIATED EMISSION UP TO 1 GHZ

3.1.1 LIMITS

Class B equipment up to 1000MHz

| Frequency MHz | Measurement | | Class B limit dB(uV/m) |
|------------------|---------------|----------------------------|------------------------|
| | Distance m | Detector type/bandwidth | SAC |
| 30-230 | 10 | Quasi peak / 120 kHz | 30 |
| 230-1000 | | | 37 |

Notes:

- (1) The limit for radiated test was performed according to as following: EN 55032
- (2) The tighter limit applies at the band edges.
- (3) Emission level (dBuV/m)=20log Emission level (uV/m).
- (4) The test result calculated as following:
 Measurement Value = Reading Level + Correct Factor
 Correct Factor = Antenna Factor + Cable Loss - Amplifier Gain(if use)
 Margin Level = Measurement Value - Limit Value

3.1.2 MEASUREMENT INSTRUMENTS LIST

| Item | Kind of Equipment | Manufacturer | Type No. | Series Model | Calibrated until |
|------|-----------------------------|-------------------|--------------------------|--------------|------------------|
| 1 | Receiver | Keysight | N9038A | MY54450004 | Jul. 25, 2021 |
| 2 | Pre-Amplifier | EMC INSTRUMENT | EMC 9135 | 980284 | Dec. 13, 2021 |
| 3 | Pre-Amplifier | EMC INSTRUMENT | EMC 9135 | 980283 | Dec. 13, 2021 |
| 4 | Trilog-Broadband Antenna | Schwarzbeck | VULB9168 | 946 | Oct. 16, 2021 |
| 5 | Trilog-Broadband Antenna | Schwarzbeck | VULB9168 | 947 | Nov. 09, 2021 |
| 6 | Cable | emci | LMR-400 (5m+8m+8m) | N/A | Jan. 06, 2022 |
| 7 | Measurement Software | Farad | EZ-EMC Ver.BTL-2ANT-1 | N/A | N/A |
| 8 | Multi-Device Controller | ETS-Lindgren | 2090 | N/A | N/A |
| 9 | Attenuator | EMCI | EMCI-N-6-06 | N0670 | Nov. 09, 2021 |
| 10 | Attenuator | EMCI | EMCI-N-6-06 | N0671 | Oct. 16, 2021 |

Remark: "N/A" denotes no model no., no serial no. or no calibration specified.

All calibration period of equipment list is one year.

3.1.3 TEST PROCEDURE

- a. The measuring distance of 10 m shall be used for measurements. The EUT was placed on the top of a rotating table 0.8 meter above the ground at a 10 meter semi-anechoic chamber. The table was rotated 360 degrees to determine the position of the highest radiation.(below 1GHz).
- c. The height of the equipment or of the substitution antenna shall be 0.8 m, the height of the test antenna shall vary between 1 m to 4 m. Both horizontal and vertical polarizations of the antenna are set to make the measurement.
- d. The initial step in collecting radiated emission data is a receiver peak detector mode pre-scanning the measurement frequency range. Significant peaks are then marked and then Quasi Peak detector mode re-measured.
- e. All readings are Peak unless otherwise stated QP in column of Note. Peak denotes that the Peak reading compliance with the QP Limits and then QP Mode measurement didn't perform.
(below 1GHz)
- g. For the actual test configuration, please refer to the related Item - Block Diagram of system tested.

3.1.4 DEVIATION FROM TEST STANDARD

No deviation

3.1.5 TEST SETUP

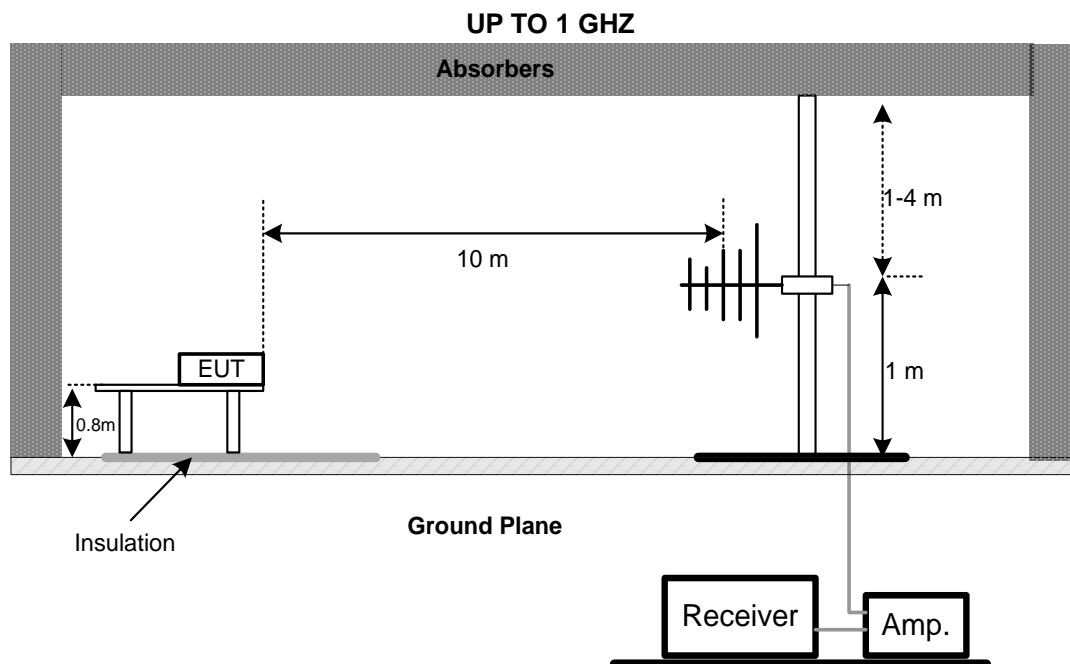

Note: The antenna can be moved between 1 to 4 meters above the ground.

3.1.6 MEASUREMENT DISTANCE

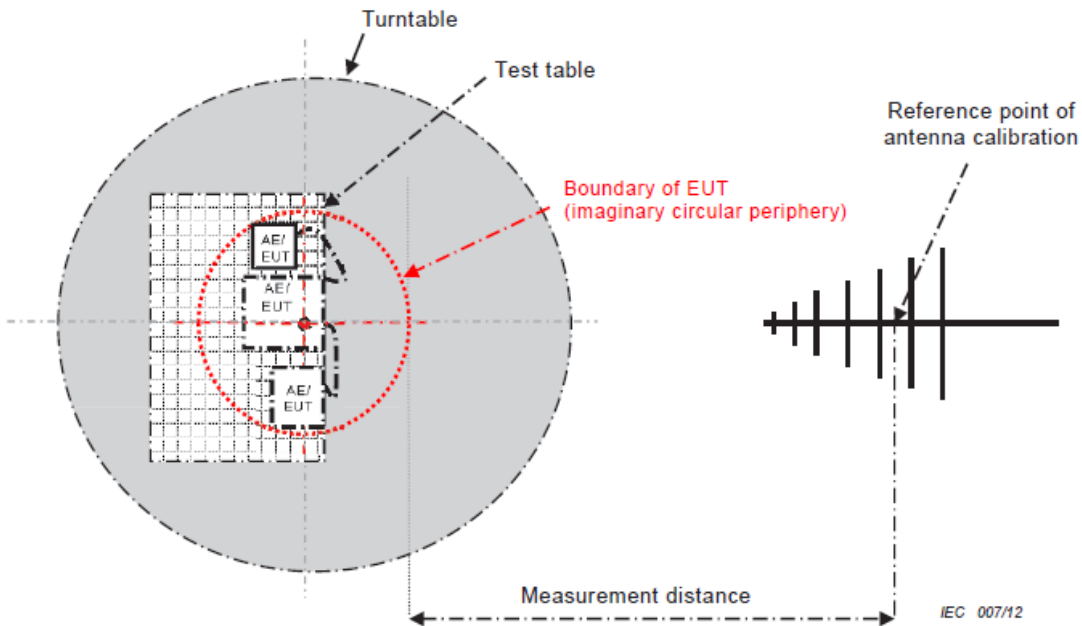

- 34 -

CISPR 32 © IEC:2012

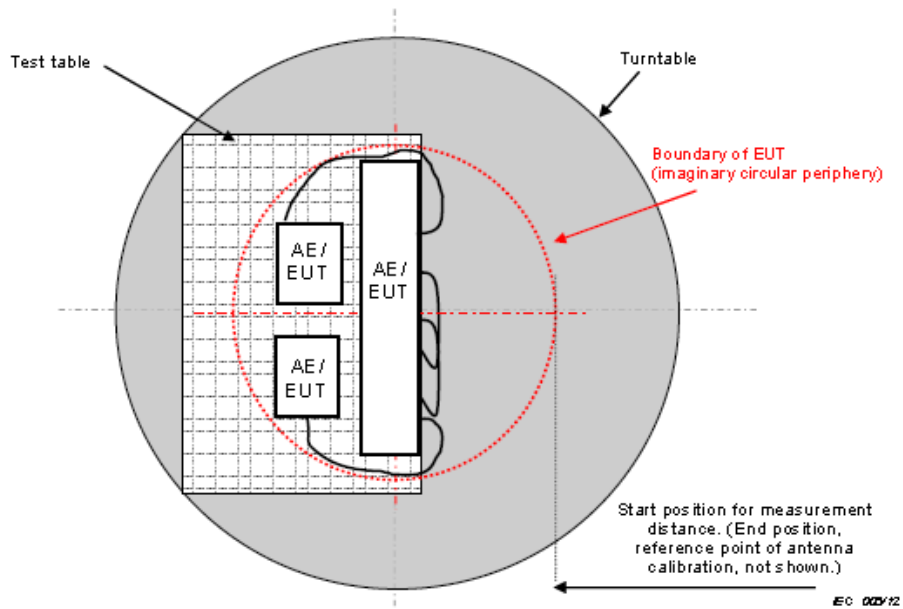
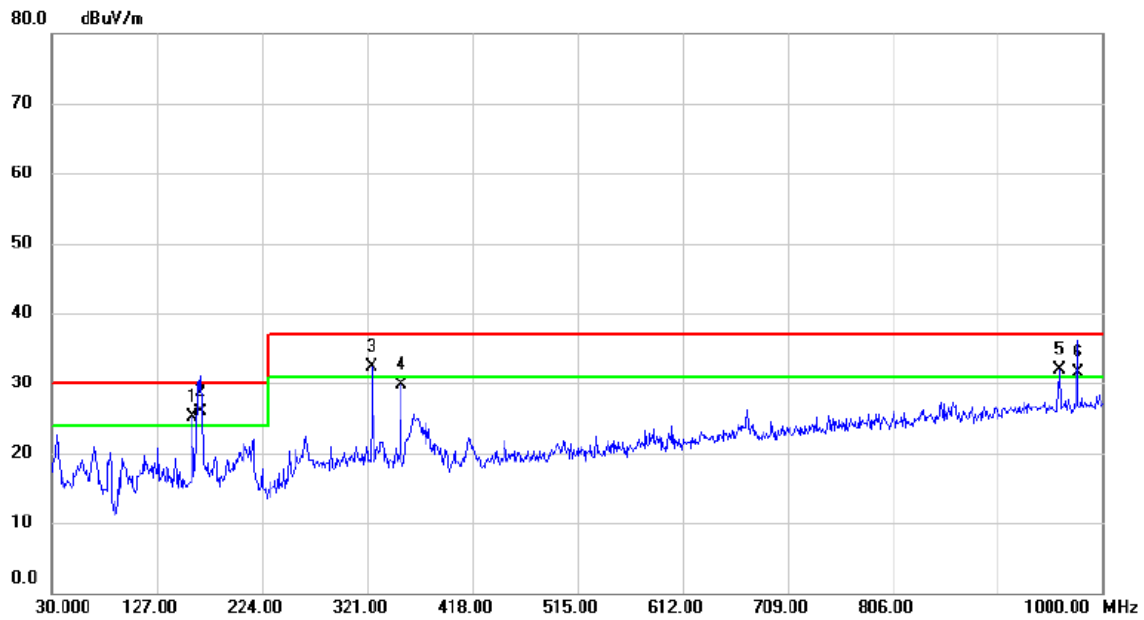

Figure C.2 – Boundary of EUT, Local AE and associated cabling

3.1.7 TEST RESULTS (UP TO 1 GHz)

| | | | |
|--------------|--------------|--------------|----------|
| Test Voltage | AC 230V/50Hz | Polarization | Vertical |
| Test Mode | Mode 1 | | |



| No. | Mk. | Freq. MHz | Reading Level dBuV | Correct Factor dB | Measure- ment dBuV/m | Limit dBuV/m | Margin dB | Detector | Comment |
|-----|-----|--------------|--------------------------|-------------------------|----------------------------|-----------------|--------------|----------|---------|
| 1 | ! | 159.9800 | 42.11 | -16.96 | 25.15 | 30.00 | -4.85 | QP | |
| 2 | * | 167.7400 | 43.17 | -17.18 | 25.99 | 30.00 | -4.01 | QP | |
| 3 | ! | 325.8500 | 47.01 | -14.73 | 32.28 | 37.00 | -4.72 | QP | |
| 4 | | 352.0400 | 43.85 | -14.23 | 29.62 | 37.00 | -7.38 | QP | |
| 5 | ! | 960.2300 | 37.44 | -5.45 | 31.99 | 37.00 | -5.01 | QP | |
| 6 | ! | 976.7200 | 36.86 | -5.33 | 31.53 | 37.00 | -5.47 | QP | |

| | | | |
|--------------|--------------|--------------|------------|
| Test Voltage | AC 230V/50Hz | Polarization | Horizontal |
| Test Mode | Mode 1 | | |

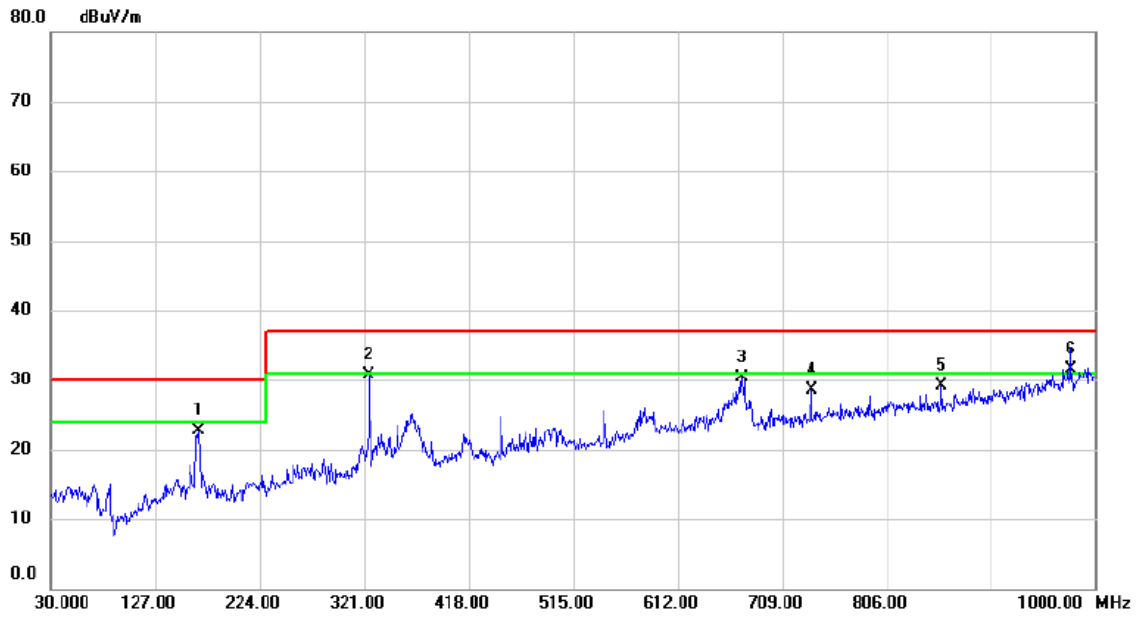

| No. | Mk. | Freq. MHz | Reading Level dBuV | Correct Factor dB | Measure- ment dBuV/m | Limit dBuV/m | Margin dB | Detector | Comment |
|-----|-----|--------------|--------------------------|-------------------------|----------------------------|-----------------|--------------|----------|---------|
| 1 | | 167.7400 | 39.10 | -16.45 | 22.65 | 30.00 | -7.35 | QP | |
| 2 | | 325.8500 | 45.07 | -14.46 | 30.61 | 37.00 | -6.39 | QP | |
| 3 | | 672.1400 | 38.23 | -8.01 | 30.22 | 37.00 | -6.78 | QP | |
| 4 | | 736.1600 | 35.70 | -7.20 | 28.50 | 37.00 | -8.50 | QP | |
| 5 | | 857.4100 | 35.51 | -6.49 | 29.02 | 37.00 | -7.98 | QP | |
| 6 | * | 976.7200 | 36.15 | -4.62 | 31.53 | 37.00 | -5.47 | QP | |

| | | | |
|--------------|--------------|--------------|----------|
| Test Voltage | AC 230V/50Hz | Polarization | Vertical |
| Test Mode | Mode 2 | | |

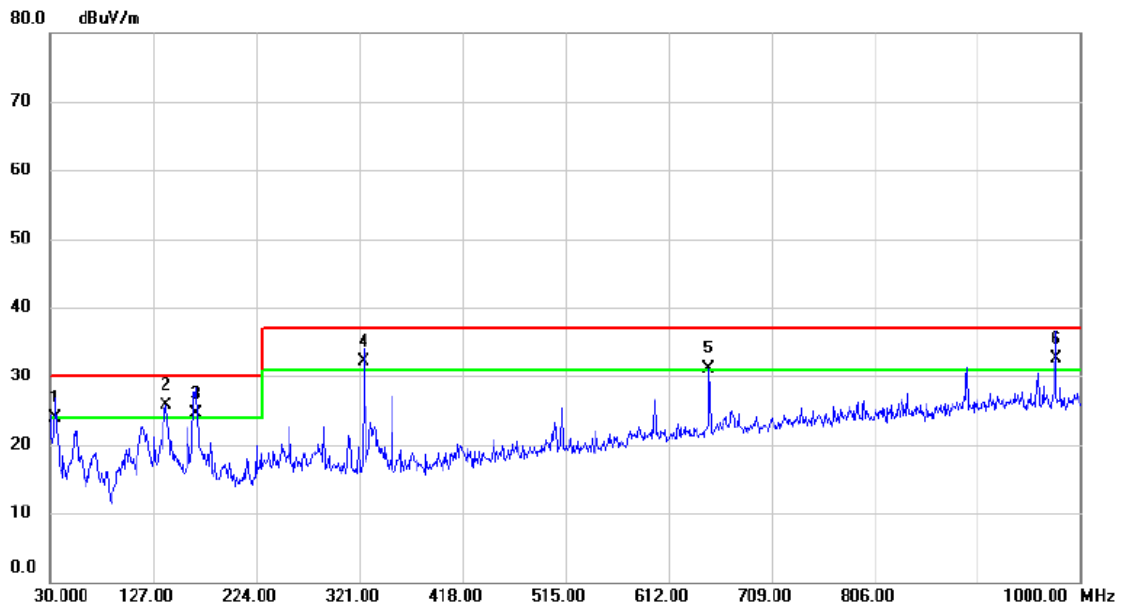

| No. | Mk. | Freq. MHz | Reading Level dBuV | Correct Factor dB | Measure- ment dBuV/m | Limit dBuV/m | Margin dB | Detector | Comment |
|-----|-----|--------------|--------------------------|-------------------------|----------------------------|-----------------|--------------|----------|---------|
| 1 | | 34.8500 | 42.77 | -18.87 | 23.90 | 30.00 | -6.10 | QP | |
| 2 | * | 139.6100 | 43.19 | -17.57 | 25.62 | 30.00 | -4.38 | QP | |
| 3 | ! | 167.7400 | 41.71 | -17.18 | 24.53 | 30.00 | -5.47 | QP | |
| 4 | ! | 325.8500 | 46.88 | -14.73 | 32.15 | 37.00 | -4.85 | QP | |
| 5 | ! | 650.8000 | 39.59 | -8.44 | 31.15 | 37.00 | -5.85 | QP | |
| 6 | ! | 976.7200 | 37.86 | -5.33 | 32.53 | 37.00 | -4.47 | QP | |

| | | | |
|--------------|--------------|--------------|------------|
| Test Voltage | AC 230V/50Hz | Polarization | Horizontal |
| Test Mode | Mode 2 | | |

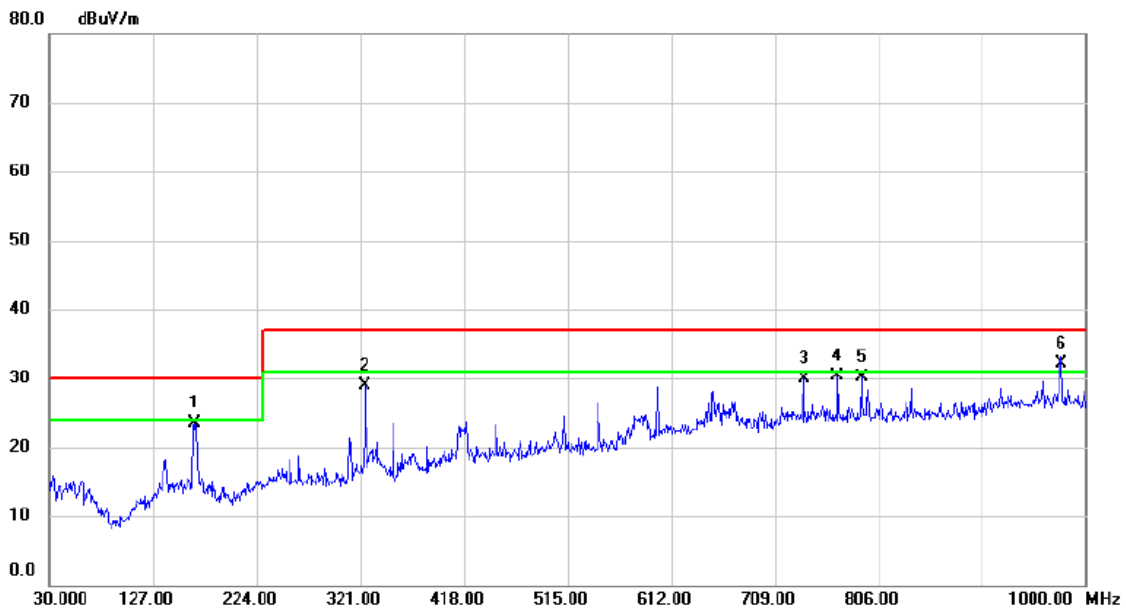

| No. | Mk. | Freq. MHz | Reading Level dBuV | Correct Factor dB | Measure- ment dBuV/m | Limit dBuV/m | Margin dB | Detector | Comment |
|-----|-----|--------------|--------------------------|-------------------------|----------------------------|-----------------|--------------|----------|---------|
| 1 | | 165.8000 | 39.98 | -16.39 | 23.59 | 30.00 | -6.41 | QP | |
| 2 | | 325.8500 | 43.28 | -14.46 | 28.82 | 37.00 | -8.18 | QP | |
| 3 | | 736.1600 | 37.16 | -7.20 | 29.96 | 37.00 | -7.04 | QP | |
| 4 | | 768.1700 | 37.14 | -6.80 | 30.34 | 37.00 | -6.66 | QP | |
| 5 | | 790.4800 | 36.60 | -6.58 | 30.02 | 37.00 | -6.98 | QP | |
| 6 | * | 976.7200 | 36.77 | -4.62 | 32.15 | 37.00 | -4.85 | QP | |

| | | | |
|--------------|--------------|--------------|----------|
| Test Voltage | AC 230V/50Hz | Polarization | Vertical |
| Test Mode | Mode 5 | | |

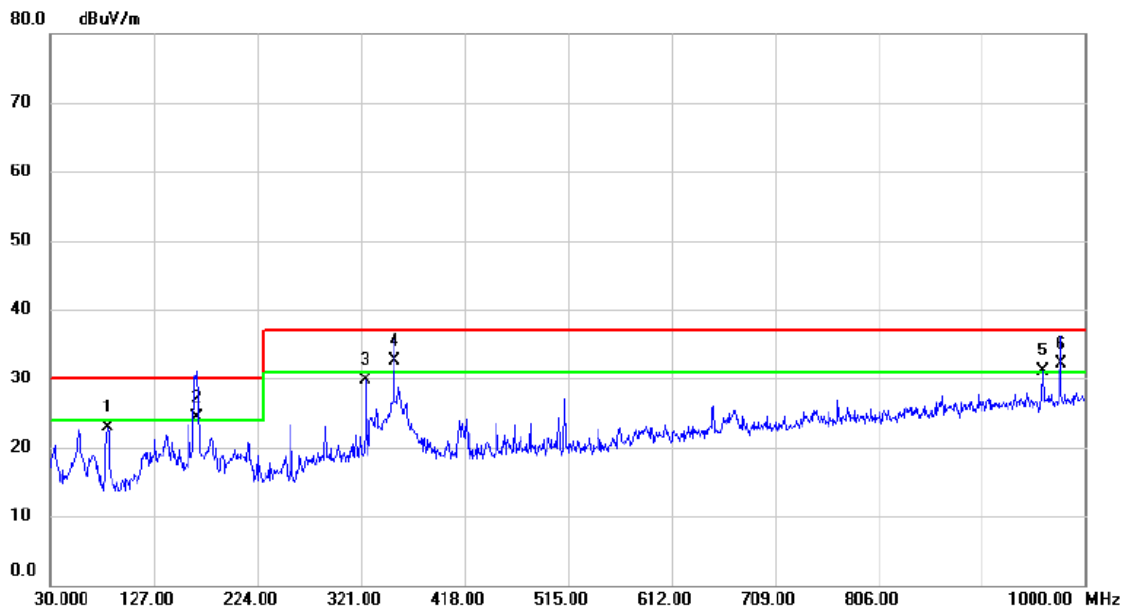

| No. | Mk. | Freq. MHz | Reading Level dBuV | Correct Factor dB | Measure- ment dBuV/m | Limit dBuV/m | Margin dB | Detector | Comment |
|-----|-----|--------------|--------------------------|-------------------------|----------------------------|-----------------|--------------|----------|---------|
| 1 | | 83.3500 | 45.43 | -22.48 | 22.95 | 30.00 | -7.05 | QP | |
| 2 | ! | 167.7400 | 41.54 | -17.18 | 24.36 | 30.00 | -5.64 | QP | |
| 3 | | 325.8500 | 44.42 | -14.73 | 29.69 | 37.00 | -7.31 | QP | |
| 4 | * | 352.0400 | 46.68 | -14.23 | 32.45 | 37.00 | -4.55 | QP | |
| 5 | ! | 960.2300 | 36.53 | -5.45 | 31.08 | 37.00 | -5.92 | QP | |
| 6 | ! | 976.7200 | 37.48 | -5.33 | 32.15 | 37.00 | -4.85 | QP | |

| | | | |
|--------------|--------------|--------------|------------|
| Test Voltage | AC 230V/50Hz | Polarization | Horizontal |
| Test Mode | Mode 5 | | |

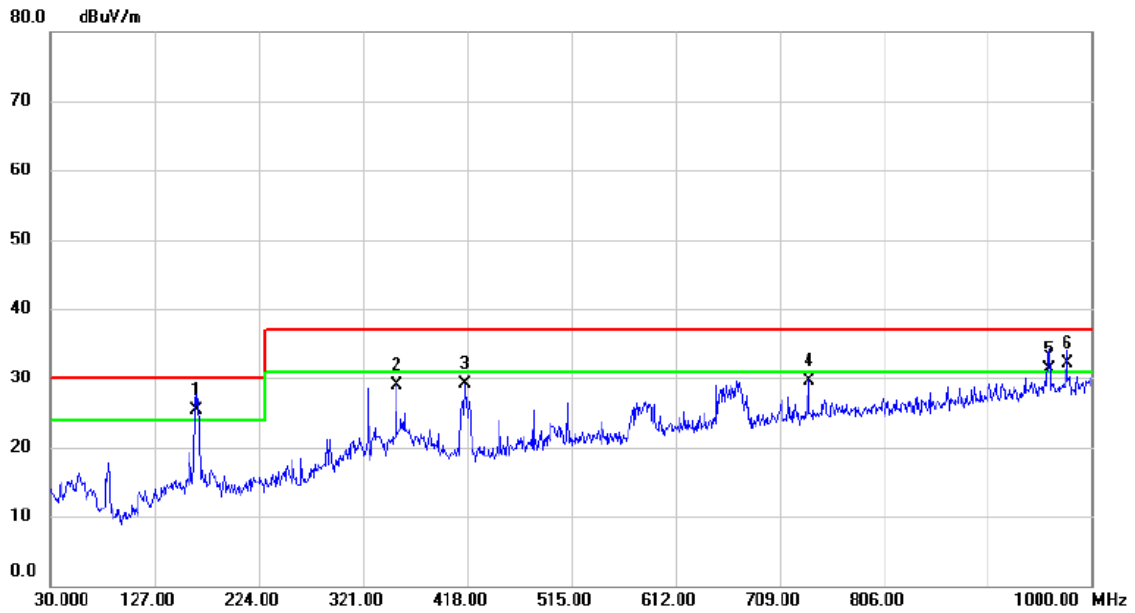

| No. | Mk. | Freq. MHz | Reading Level dBuV | Correct Factor dB | Measure- ment dBuV/m | Limit dBuV/m | Margin dB | Detector | Comment |
|-----|-----|--------------|--------------------------|-------------------------|----------------------------|-----------------|--------------|----------|---------|
| 1 | * | 165.8000 | 41.72 | -16.39 | 25.33 | 30.00 | -4.67 | QP | |
| 2 | | 352.0400 | 42.70 | -13.84 | 28.86 | 37.00 | -8.14 | QP | |
| 3 | | 416.0600 | 41.31 | -12.17 | 29.14 | 37.00 | -7.86 | QP | |
| 4 | | 736.1600 | 36.80 | -7.20 | 29.60 | 37.00 | -7.40 | QP | |
| 5 | ! | 960.2300 | 35.95 | -4.69 | 31.26 | 37.00 | -5.74 | QP | |
| 6 | ! | 976.7200 | 36.77 | -4.62 | 32.15 | 37.00 | -4.85 | QP | |

| | | | |
|--------------|--------------|--------------|----------|
| Test Voltage | AC 230V/50Hz | Polarization | Vertical |
| Test Mode | Mode 11 | | |

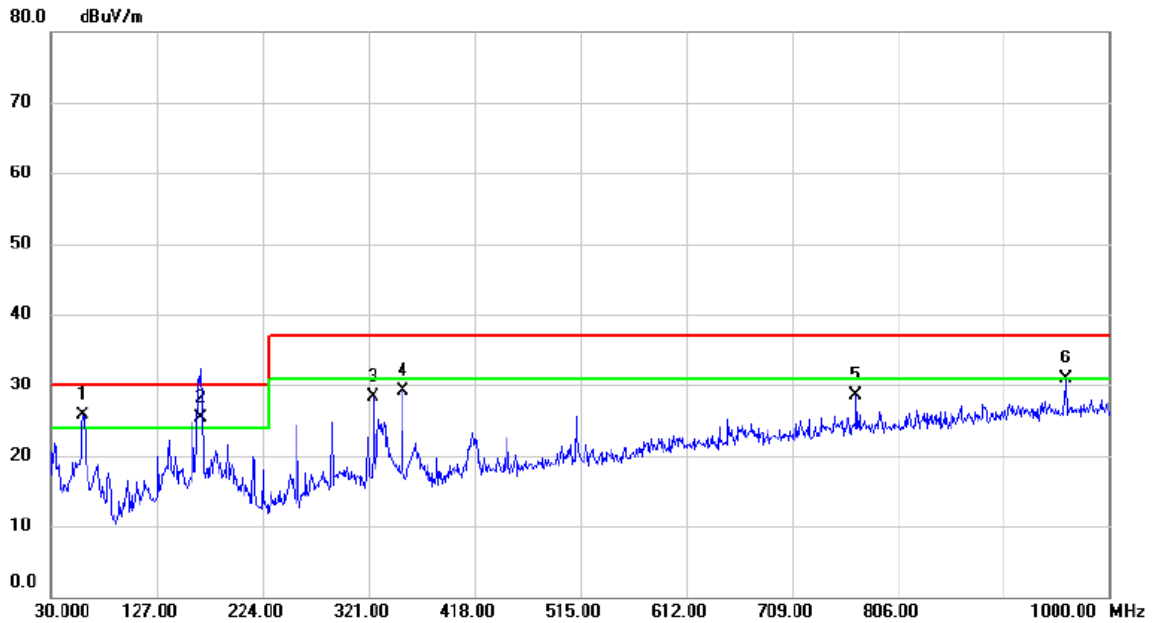

| No. | Mk. | Freq. MHz | Reading Level dBuV | Correct Factor dB | Measure- ment dBuV/m | Limit dBuV/m | Margin dB | Detector | Comment |
|-----|-----|--------------|--------------------------|-------------------------|----------------------------|-----------------|--------------|----------|---------|
| 1 | * | 59.1000 | 43.60 | -17.86 | 25.74 | 30.00 | -4.26 | QP | |
| 2 | ! | 167.7400 | 42.53 | -17.18 | 25.35 | 30.00 | -4.65 | QP | |
| 3 | | 325.8500 | 43.01 | -14.73 | 28.28 | 37.00 | -8.72 | QP | |
| 4 | | 352.0400 | 43.27 | -14.23 | 29.04 | 37.00 | -7.96 | QP | |
| 5 | | 768.1700 | 35.56 | -7.13 | 28.43 | 37.00 | -8.57 | QP | |
| 6 | | 960.2300 | 36.40 | -5.45 | 30.95 | 37.00 | -6.05 | QP | |

| | | | |
|--------------|--------------|--------------|------------|
| Test Voltage | AC 230V/50Hz | Polarization | Horizontal |
| Test Mode | Mode 11 | | |

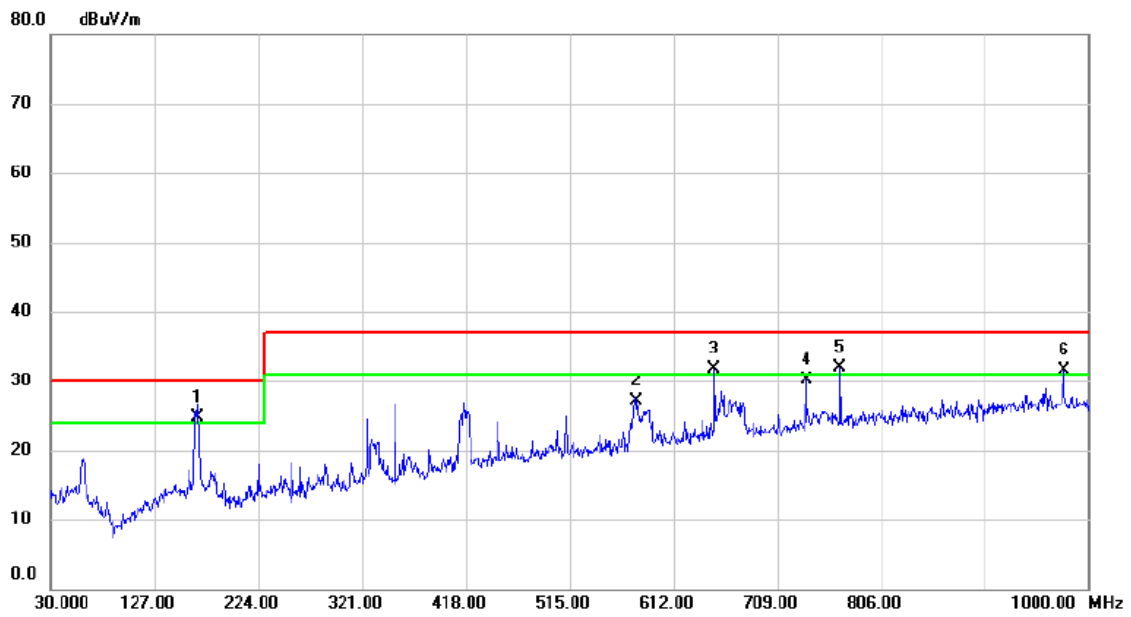

| No. | Mk. | Freq. MHz | Reading Level dBuV | Correct Factor dB | Measure- ment dBuV/m | Limit dBuV/m | Margin dB | Detector | Comment |
|-----|-----|--------------|--------------------------|-------------------------|----------------------------|-----------------|--------------|----------|---------|
| 1 | ! | 167.7400 | 41.17 | -16.45 | 24.72 | 30.00 | -5.28 | QP | |
| 2 | | 578.0500 | 36.43 | -9.24 | 27.19 | 37.00 | -9.81 | QP | |
| 3 | ! | 650.8000 | 39.87 | -8.16 | 31.71 | 37.00 | -5.29 | QP | |
| 4 | | 736.1600 | 37.25 | -7.20 | 30.05 | 37.00 | -6.95 | QP | |
| 5 | * | 768.1700 | 38.62 | -6.80 | 31.82 | 37.00 | -5.18 | QP | |
| 6 | ! | 976.7200 | 36.09 | -4.62 | 31.47 | 37.00 | -5.53 | QP | |

| | | | |
|--------------|--------------|--------------|----------|
| Test Voltage | AC 110V/60Hz | Polarization | Vertical |
| Test Mode | Mode 1 | | |

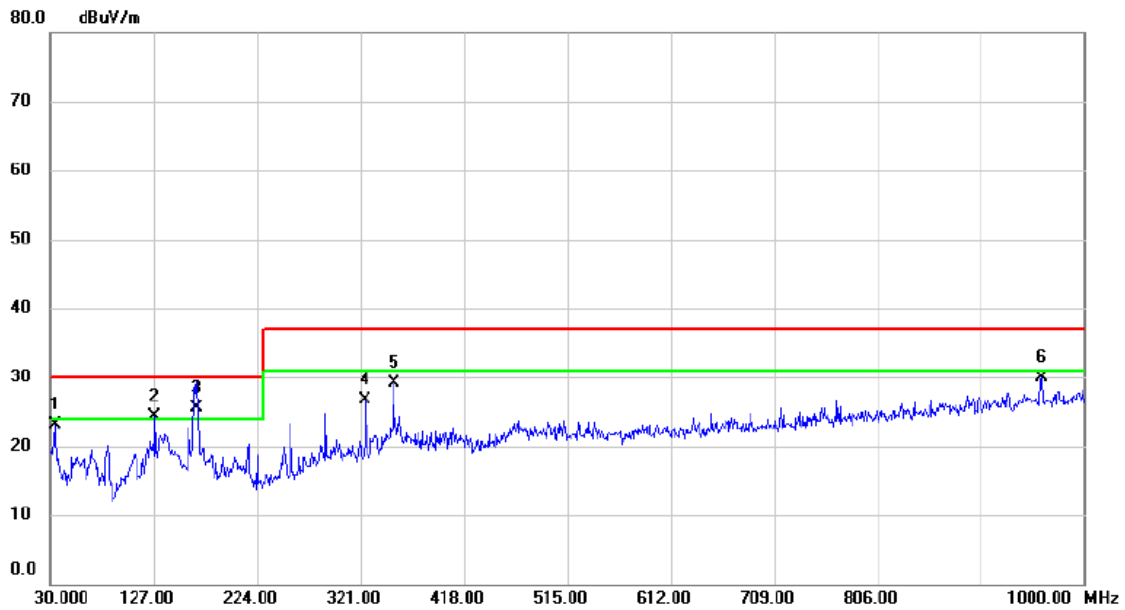

| No. | Mk. | Freq. MHz | Reading Level dBuV | Correct Factor dB | Measure- ment dBuV/m | Limit dBuV/m | Margin dB | Detector | Comment |
|-----|-----|--------------|--------------------------|-------------------------|----------------------------|-----------------|--------------|----------|---------|
| 1 | | 33.8800 | 42.01 | -18.93 | 23.08 | 30.00 | -6.92 | QP | |
| 2 | | 127.9700 | 43.30 | -18.95 | 24.35 | 30.00 | -5.65 | QP | |
| 3 | * | 167.7400 | 42.63 | -17.18 | 25.45 | 30.00 | -4.55 | QP | |
| 4 | | 325.8500 | 41.36 | -14.73 | 26.63 | 37.00 | -10.37 | QP | |
| 5 | | 352.0400 | 43.43 | -14.23 | 29.20 | 37.00 | -7.80 | QP | |
| 6 | | 960.2300 | 35.43 | -5.45 | 29.98 | 37.00 | -7.02 | QP | |

| | | | |
|--------------|--------------|--------------|------------|
| Test Voltage | AC 110V/60Hz | Polarization | Horizontal |
| Test Mode | Mode 1 | | |

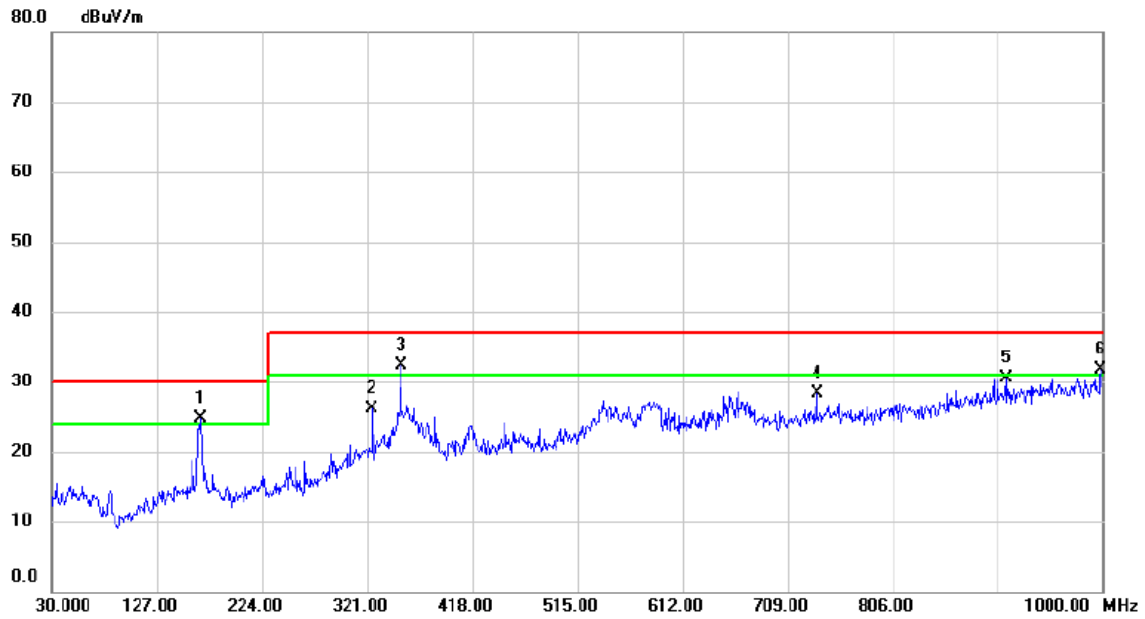

| No. | Mk. | Freq. MHz | Reading Level dBuV | Correct Factor dB | Measure- ment dBuV/m | Limit dBuV/m | Margin dB | Detector | Comment |
|-----|-----|--------------|--------------------------|-------------------------|----------------------------|-----------------|--------------|----------|---------|
| 1 | ! | 167.7400 | 41.23 | -16.45 | 24.78 | 30.00 | -5.22 | QP | |
| 2 | | 325.8500 | 40.60 | -14.46 | 26.14 | 37.00 | -10.86 | QP | |
| 3 | * | 352.0400 | 46.07 | -13.84 | 32.23 | 37.00 | -4.77 | QP | |
| 4 | | 736.1600 | 35.50 | -7.20 | 28.30 | 37.00 | -8.70 | QP | |
| 5 | | 910.7600 | 36.27 | -5.71 | 30.56 | 37.00 | -6.44 | QP | |
| 6 | ! | 998.0600 | 36.18 | -4.54 | 31.64 | 37.00 | -5.36 | QP | |

3.2 RADIATED EMISSION ABOVE 1 GHZ

3.2.1 LIMITS

Class B equipment above 1000MHz

| Frequency MHz | Measurement | | Class B limit dB(uV/m) |
|------------------|---------------|----------------------------|------------------------|
| | Distance m | Detector type/bandwidth | FSOATS |
| 1000-3000 | 3 | Average / 1 MHz | 50 |
| 3000-6000 | | | 54 |
| 1000-3000 | | Peak / 1 MHz | 70 |
| 3000-6000 | | | 74 |

Notes:

- (1) The limit for radiated test was performed according to as following: EN 55032
- (2) The tighter limit applies at the band edges.
- (3) Emission level (dBuV/m)=20log Emission level (uV/m).
- (4) The test result calculated as following:
 Measurement Value = Reading Level + Correct Factor
 Correct Factor = Antenna Factor + Cable Loss - Amplifier Gain(if use)
 Margin Level = Measurement Value - Limit Value

Required highest frequency for radiated measurement

| Highest internal frequency (F_x) MHz | Highest measured frequency MHz |
|---|--|
| $F_x \leq 108$ | 1000 |
| $108 < F_x \leq 500$ | 2000 |
| $500 < F_x \leq 1000$ | 5000 |
| $F_x > 1000$ | 5 th up to a maximum 6 GHz, |

Note for FM and TV broadcast receiver, F_x is determined from the highest frequency generated or used excluding the local oscillator and tuned frequencies.

3.2.2 MEASUREMENT INSTRUMENTS LIST

| Item | Kind of Equipment | Manufacturer | Type No. | Series Model | Calibrated until |
|------|-------------------------|--------------|--------------------------|--------------|------------------|
| 1 | Horn Antenna | EMCO | 3115 | 9605-4803 | May 10, 2022 |
| 2 | Amplifier | Agilent | 8449B | 3008A02333 | Feb. 28, 2022 |
| 3 | MXE EMI Receiver | Agilent | N9038A | MY53220133 | Feb. 28, 2022 |
| 4 | Measurement Software | Farad | EZ-EMC Ver.BTL-2ANT-1 | N/A | N/A |
| 5 | Multi-Device Controller | ETS-Lindgren | 2090 | N/A | N/A |
| 6 | Controller | MF | MF-7802 | MF780208159 | N/A |
| 7 | Cable | Mlcable Inc. | B10-01-01-5M | 18047123 | Jan. 06, 2022 |
| 8 | Cable | Mlcable Inc. | B10-01-01-12M | 18072743 | Jan. 06, 2022 |
| 9 | Cable | RegalWay | RWLPS50-7.9A- SMSM-1M | 20200102 001 | Jan. 06, 2022 |

Remark: "N/A" denotes no model no., no serial no. or no calibration specified.

All calibration period of equipment list is one year.

3.2.3 TEST PROCEDURE

- The measuring distance of 3 m shall be used for measurements. The EUT was placed on the top of a rotating table 0.8 meter above the ground at a 10 meter semi-anechoic chamber. The table was rotated 360 degrees to determine the position of the highest radiation. (above 1GHz)
- The height of the equipment or of the substitution antenna shall be 0.8 m, the height of the test antenna shall vary between 1 m to 4 m. Both horizontal and vertical polarizations of the antenna are set to make the measurement.
- The initial step in collecting radiated emission data is a receiver peak detector mode pre-scanning the measurement frequency range. Significant peaks are then marked and then Quasi Peak detector mode re-measured.
- All readings are Peak Mode value unless otherwise stated AVG in column of Note. If the Peak Mode Measured value compliance with the Peak Limits and lower than AVG Limits, the EUT shall be deemed to meet both Peak & AVG Limits and then only Peak Mode was measured, but AVG Mode didn't perform. (above 1GHz)
- For the actual test configuration, please refer to the related Item - Block Diagram of system tested.

3.2.4 DEVIATION FROM TEST STANDARD

No deviation

3.2.5 TEST SETUP

ABOVE 1 GHz

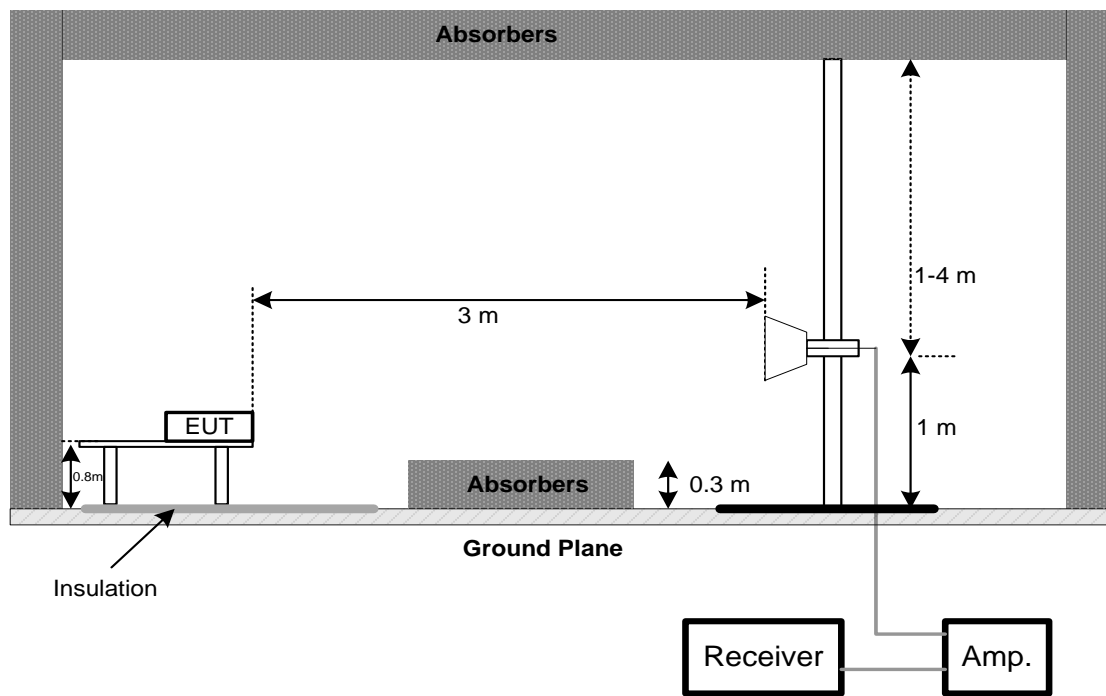

3.2.6 MEASUREMENT DISTANCE

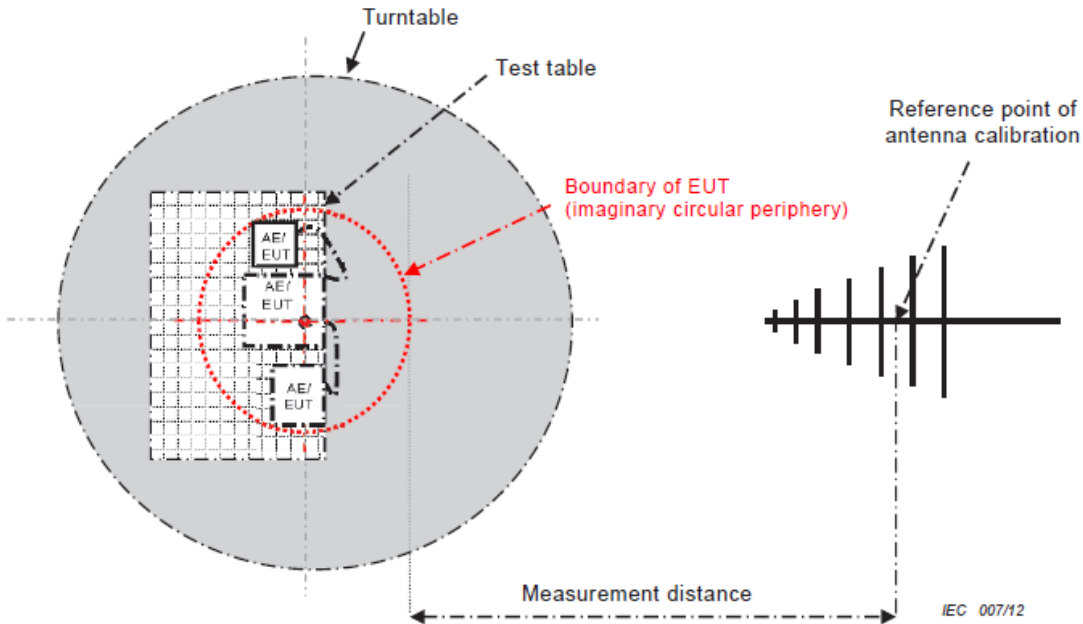

- 34 -

CISPR 32 © IEC:2012

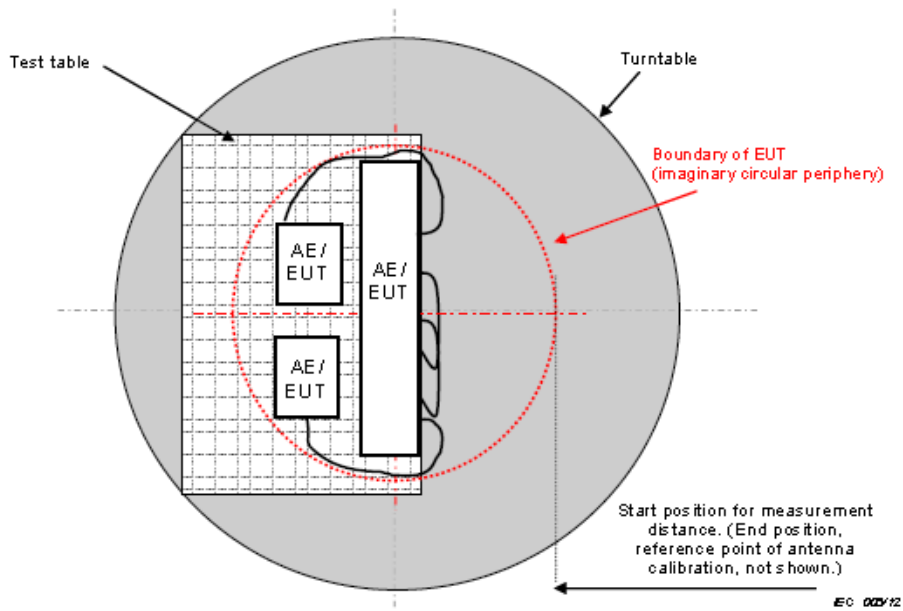
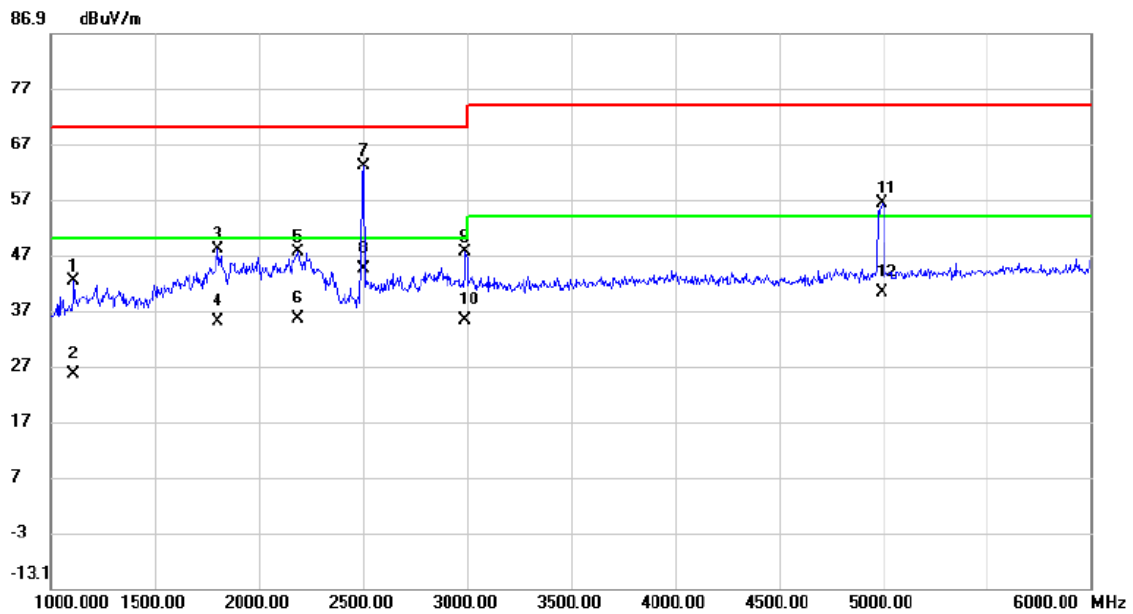

Figure C.2 – Boundary of EUT, Local AE and associated cabling

3.2.7 TEST RESULTS (ABOVE 1 GHZ)

| | | | |
|--------------|--------------|--------------|----------|
| Test Voltage | AC 230V/50Hz | Polarization | Vertical |
| Test Mode | Mode 1 | | |



| No. | Mk. | Freq. MHz | Reading Level dBuV | Correct Factor dB | Measure- ment dBuV/m | Limit dBuV/m | Margin dB | Detector | Comment |
|-----|-----|--------------|--------------------------|-------------------------|----------------------------|-----------------|--------------|----------|---------|
| 1 | | 1112.500 | 46.73 | -4.46 | 42.27 | 70.00 | -27.73 | peak | |
| 2 | | 1112.500 | 29.93 | -4.46 | 25.47 | 50.00 | -24.53 | AVG | |
| 3 | | 1805.000 | 49.19 | -1.08 | 48.11 | 70.00 | -21.89 | peak | |
| 4 | | 1805.000 | 36.18 | -1.08 | 35.10 | 50.00 | -14.90 | AVG | |
| 5 | | 2187.500 | 46.58 | 0.86 | 47.44 | 70.00 | -22.56 | peak | |
| 6 | | 2187.500 | 34.77 | 0.86 | 35.63 | 50.00 | -14.37 | AVG | |
| 7 | | 2500.000 | 61.04 | 2.02 | 63.06 | 70.00 | -6.94 | peak | |
| 8 | * | 2500.000 | 42.51 | 2.02 | 44.53 | 50.00 | -5.47 | AVG | |
| 9 | | 2992.500 | 43.30 | 4.22 | 47.52 | 70.00 | -22.48 | peak | |
| 10 | | 2992.500 | 30.98 | 4.22 | 35.20 | 50.00 | -14.80 | AVG | |
| 11 | | 4997.500 | 46.19 | 10.09 | 56.28 | 74.00 | -17.72 | peak | |
| 12 | | 4997.500 | 30.21 | 10.09 | 40.30 | 54.00 | -13.70 | AVG | |

| | | | |
|--------------|--------------|--------------|------------|
| Test Voltage | AC 230V/50Hz | Polarization | Horizontal |
| Test Mode | Mode 1 | | |

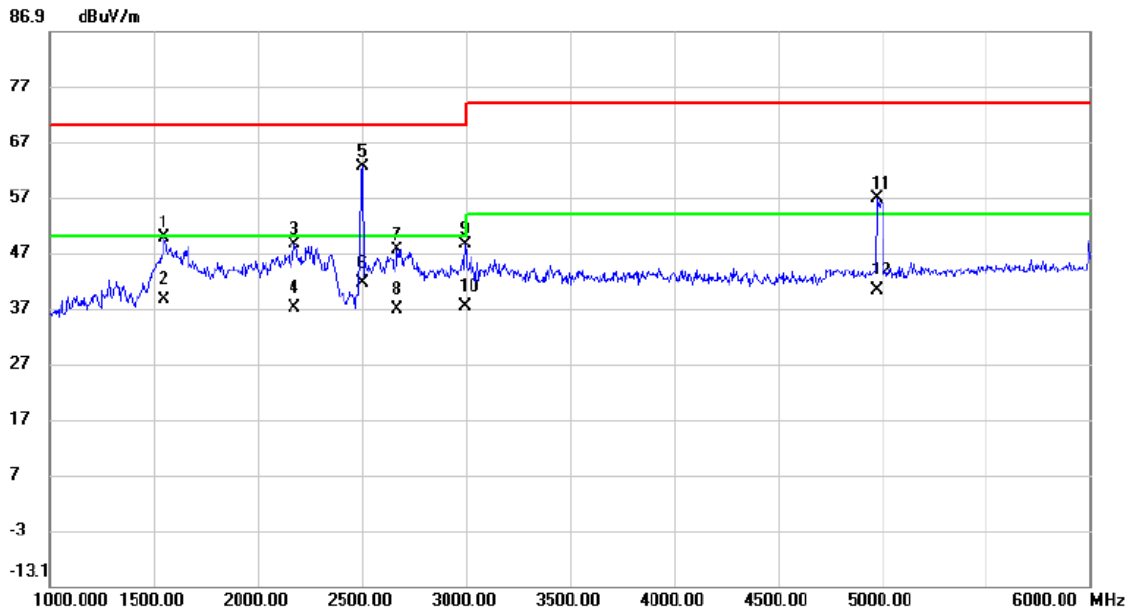

| No. | Mk. | Freq. MHz | Reading Level dBuV | Correct Factor dB | Measure- ment dBuV/m | Limit dBuV/m | Margin dB | Detector | Comment |
|-----|-----|--------------|--------------------------|-------------------------|----------------------------|-----------------|--------------|----------|---------|
| 1 | | 1550.000 | 52.36 | -2.70 | 49.66 | 70.00 | -20.34 | peak | |
| 2 | | 1550.000 | 41.14 | -2.70 | 38.44 | 50.00 | -11.56 | AVG | |
| 3 | | 2177.500 | 47.71 | 0.83 | 48.54 | 70.00 | -21.46 | peak | |
| 4 | | 2177.500 | 36.32 | 0.83 | 37.15 | 50.00 | -12.85 | AVG | |
| 5 | * | 2500.000 | 60.55 | 2.02 | 62.57 | 70.00 | -7.43 | peak | |
| 6 | | 2500.000 | 39.53 | 2.02 | 41.55 | 50.00 | -8.45 | AVG | |
| 7 | | 2672.500 | 44.84 | 2.79 | 47.63 | 70.00 | -22.37 | peak | |
| 8 | | 2672.500 | 34.06 | 2.79 | 36.85 | 50.00 | -13.15 | AVG | |
| 9 | | 2995.000 | 44.40 | 4.23 | 48.63 | 70.00 | -21.37 | peak | |
| 10 | | 2995.000 | 33.04 | 4.23 | 37.27 | 50.00 | -12.73 | AVG | |
| 11 | | 4977.500 | 46.64 | 10.03 | 56.67 | 74.00 | -17.33 | peak | |
| 12 | | 4977.500 | 30.15 | 10.03 | 40.18 | 54.00 | -13.82 | AVG | |

| | | | |
|--------------|--------------|--------------|----------|
| Test Voltage | AC 230V/50Hz | Polarization | Vertical |
| Test Mode | Mode 2 | | |

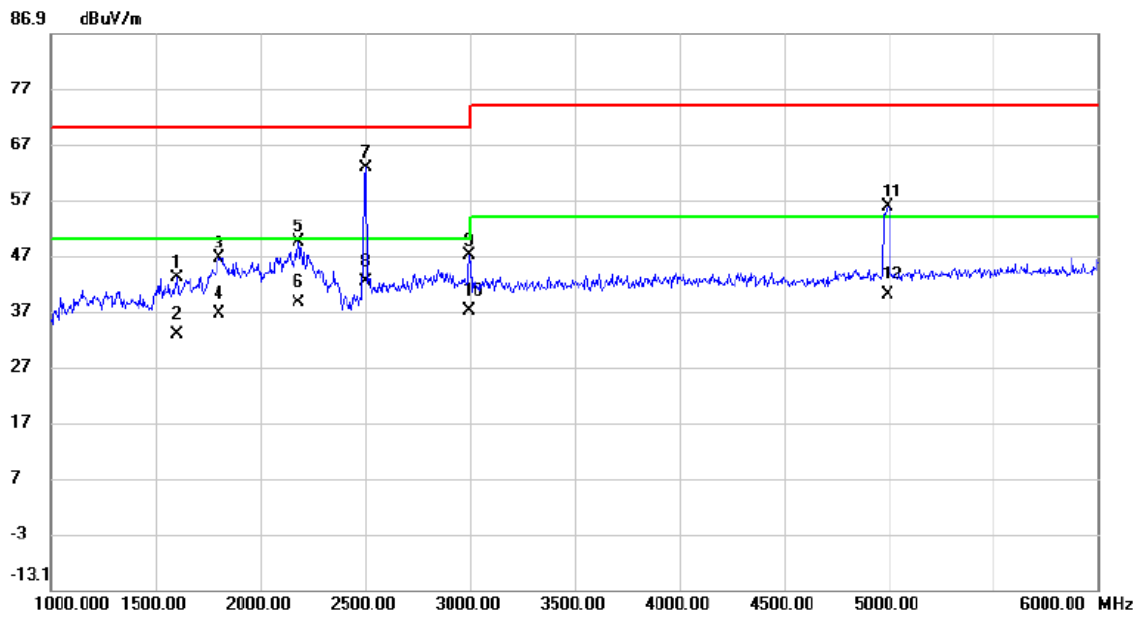

| No. | Mk. | Freq. MHz | Reading Level dBuV | Correct Factor dB | Measure- ment dBuV/m | Limit dBuV/m | Margin dB | Detector | Comment |
|-----|-----|--------------|--------------------------|-------------------------|----------------------------|-----------------|--------------|----------|---------|
| 1 | | 1605.000 | 45.32 | -2.35 | 42.97 | 70.00 | -27.03 | peak | |
| 2 | | 1605.000 | 35.02 | -2.35 | 32.67 | 50.00 | -17.33 | AVG | |
| 3 | | 1802.500 | 47.63 | -1.09 | 46.54 | 70.00 | -23.46 | peak | |
| 4 | | 1802.500 | 37.69 | -1.09 | 36.60 | 50.00 | -13.40 | AVG | |
| 5 | | 2182.500 | 48.68 | 0.84 | 49.52 | 70.00 | -20.48 | peak | |
| 6 | | 2182.500 | 37.62 | 0.84 | 38.46 | 50.00 | -11.54 | AVG | |
| 7 | * | 2500.000 | 60.82 | 2.02 | 62.84 | 70.00 | -7.16 | peak | |
| 8 | | 2500.000 | 40.21 | 2.02 | 42.23 | 50.00 | -7.77 | AVG | |
| 9 | | 2997.500 | 42.81 | 4.24 | 47.05 | 70.00 | -22.95 | peak | |
| 10 | | 2997.500 | 32.82 | 4.24 | 37.06 | 50.00 | -12.94 | AVG | |
| 11 | | 4997.500 | 45.67 | 10.09 | 55.76 | 74.00 | -18.24 | peak | |
| 12 | | 4997.500 | 30.02 | 10.09 | 40.11 | 54.00 | -13.89 | AVG | |

| | | | |
|--------------|--------------|--------------|------------|
| Test Voltage | AC 230V/50Hz | Polarization | Horizontal |
| Test Mode | Mode 2 | | |

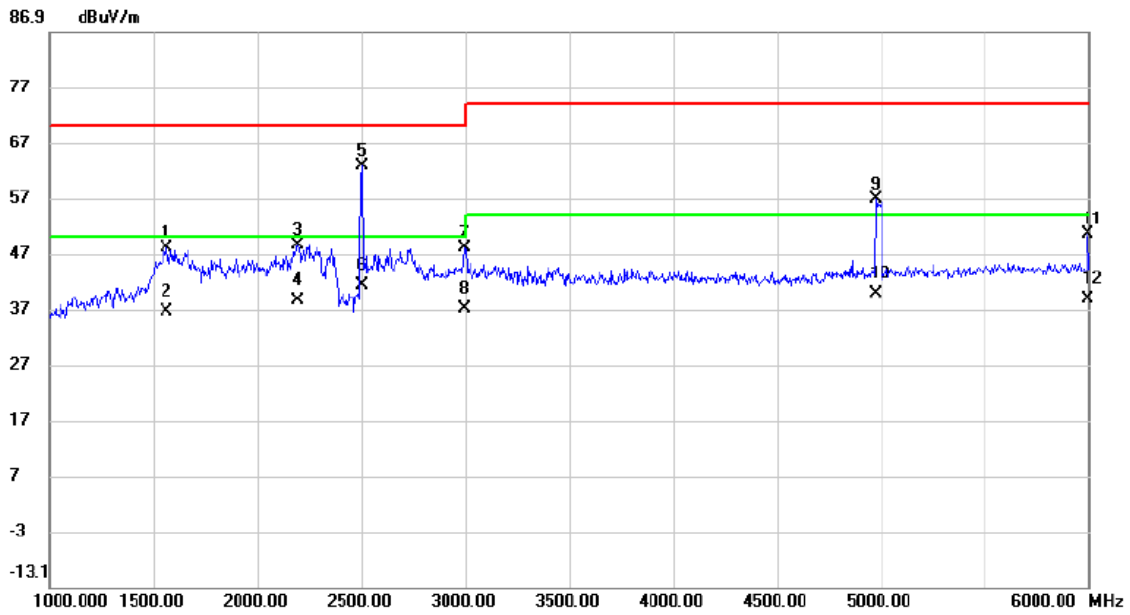

| No. | Mk. | Freq. MHz | Reading Level dBuV | Correct Factor dB | Measure- ment dBuV/m | Limit dBuV/m | Margin dB | Detector | Comment |
|-----|-----|--------------|--------------------------|-------------------------|----------------------------|-----------------|--------------|----------|---------|
| 1 | | 1560.000 | 50.63 | -2.64 | 47.99 | 70.00 | -22.01 | peak | |
| 2 | | 1560.000 | 39.27 | -2.64 | 36.63 | 50.00 | -13.37 | AVG | |
| 3 | | 2195.000 | 47.67 | 0.89 | 48.56 | 70.00 | -21.44 | peak | |
| 4 | | 2195.000 | 37.57 | 0.89 | 38.46 | 50.00 | -11.54 | AVG | |
| 5 | * | 2500.000 | 60.84 | 2.02 | 62.86 | 70.00 | -7.14 | peak | |
| 6 | | 2500.000 | 39.18 | 2.02 | 41.20 | 50.00 | -8.80 | AVG | |
| 7 | | 2997.500 | 43.71 | 4.24 | 47.95 | 70.00 | -22.05 | peak | |
| 8 | | 2997.500 | 32.73 | 4.24 | 36.97 | 50.00 | -13.03 | AVG | |
| 9 | | 4977.500 | 46.84 | 10.03 | 56.87 | 74.00 | -17.13 | peak | |
| 10 | | 4977.500 | 29.84 | 10.03 | 39.87 | 54.00 | -14.13 | AVG | |
| 11 | | 5995.000 | 38.24 | 12.18 | 50.42 | 74.00 | -23.58 | peak | |
| 12 | | 5995.000 | 26.70 | 12.18 | 38.88 | 54.00 | -15.12 | AVG | |

| | | | |
|--------------|--------------|--------------|----------|
| Test Voltage | AC 230V/50Hz | Polarization | Vertical |
| Test Mode | Mode 5 | | |

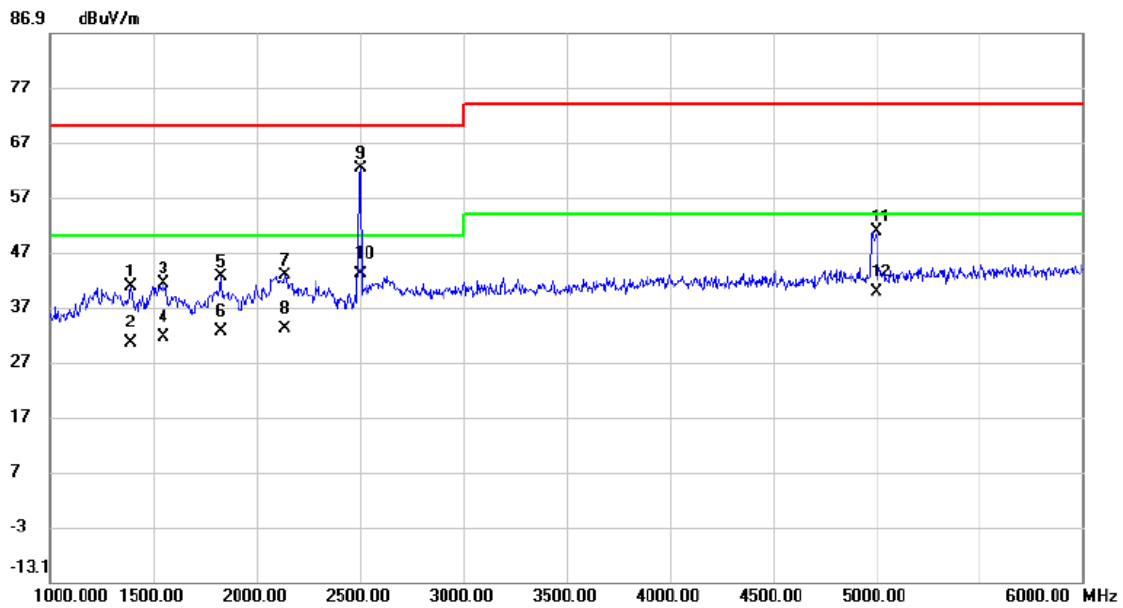

| No. | Mk. | Freq. MHz | Reading Level dBuV | Correct Factor dB | Measure- ment dBuV/m | Limit dBuV/m | Margin dB | Detector | Comment |
|-----|-----|--------------|--------------------------|-------------------------|----------------------------|-----------------|--------------|----------|---------|
| 1 | | 1392.500 | 44.29 | -3.42 | 40.87 | 70.00 | -29.13 | peak | |
| 2 | | 1392.500 | 34.01 | -3.42 | 30.59 | 50.00 | -19.41 | AVG | |
| 3 | | 1552.500 | 44.02 | -2.69 | 41.33 | 70.00 | -28.67 | peak | |
| 4 | | 1552.500 | 34.17 | -2.69 | 31.48 | 50.00 | -18.52 | AVG | |
| 5 | | 1827.500 | 43.39 | -0.93 | 42.46 | 70.00 | -27.54 | peak | |
| 6 | | 1827.500 | 33.57 | -0.93 | 32.64 | 50.00 | -17.36 | AVG | |
| 7 | | 2137.500 | 42.02 | 0.68 | 42.70 | 70.00 | -27.30 | peak | |
| 8 | | 2137.500 | 32.31 | 0.68 | 32.99 | 50.00 | -17.01 | AVG | |
| 9 | | 2500.000 | 60.26 | 2.02 | 62.28 | 70.00 | -7.72 | peak | |
| 10 | * | 2500.000 | 41.09 | 2.02 | 43.11 | 50.00 | -6.89 | AVG | |
| 11 | | 5000.000 | 40.79 | 10.09 | 50.88 | 74.00 | -23.12 | peak | |
| 12 | | 5000.000 | 29.78 | 10.09 | 39.87 | 54.00 | -14.13 | AVG | |

| | | | |
|--------------|--------------|--------------|------------|
| Test Voltage | AC 230V/50Hz | Polarization | Horizontal |
| Test Mode | Mode 5 | | |

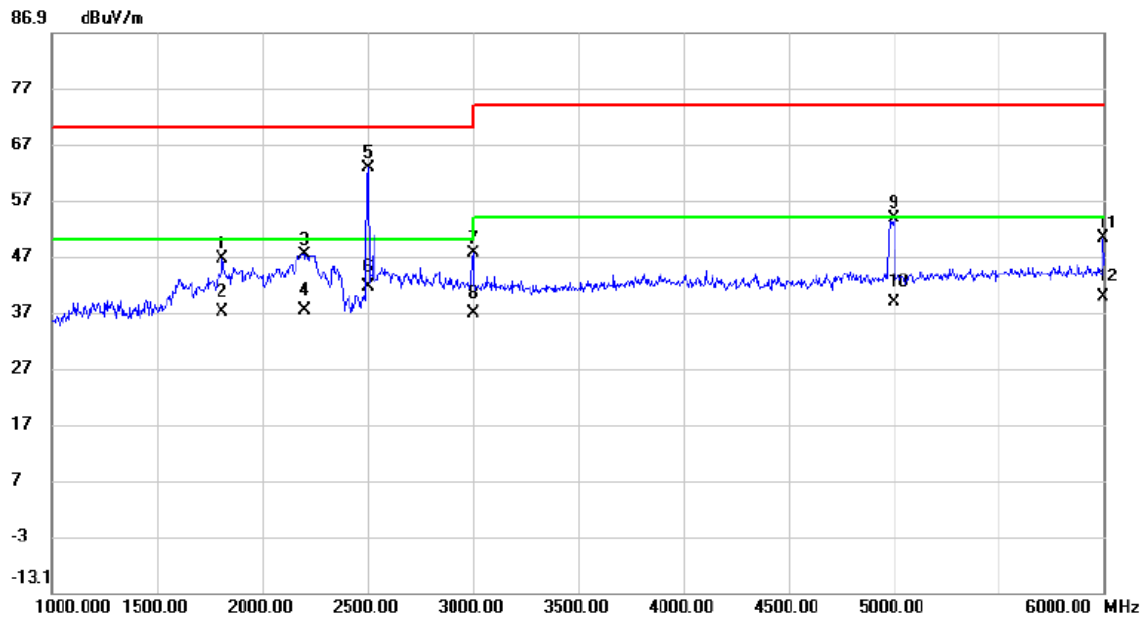

| No. | Mk. | Freq. MHz | Reading Level dBuV | Correct Factor dB | Measure- ment dBuV/m | Limit dBuV/m | Margin dB | Detector | Comment |
|-----|-----|--------------|--------------------------|-------------------------|----------------------------|-----------------|--------------|----------|---------|
| 1 | | 1812.500 | 47.47 | -1.03 | 46.44 | 70.00 | -23.56 | peak | |
| 2 | | 1812.500 | 38.01 | -1.03 | 36.98 | 50.00 | -13.02 | AVG | |
| 3 | | 2200.000 | 46.47 | 0.91 | 47.38 | 70.00 | -22.62 | peak | |
| 4 | | 2200.000 | 36.29 | 0.91 | 37.20 | 50.00 | -12.80 | AVG | |
| 5 | * | 2500.000 | 60.74 | 2.02 | 62.76 | 70.00 | -7.24 | peak | |
| 6 | | 2500.000 | 39.56 | 2.02 | 41.58 | 50.00 | -8.42 | AVG | |
| 7 | | 3000.000 | 43.16 | 4.25 | 47.41 | 70.00 | -22.59 | peak | |
| 8 | | 3000.000 | 32.45 | 4.25 | 36.70 | 50.00 | -13.30 | AVG | |
| 9 | | 5000.000 | 43.74 | 10.09 | 53.83 | 74.00 | -20.17 | peak | |
| 10 | | 5000.000 | 28.79 | 10.09 | 38.88 | 54.00 | -15.12 | AVG | |
| 11 | | 5995.000 | 38.11 | 12.18 | 50.29 | 74.00 | -23.71 | peak | |
| 12 | | 5995.000 | 27.48 | 12.18 | 39.66 | 54.00 | -14.34 | AVG | |

| | | | |
|--------------|--------------|--------------|----------|
| Test Voltage | AC 230V/50Hz | Polarization | Vertical |
| Test Mode | Mode 11 | | |

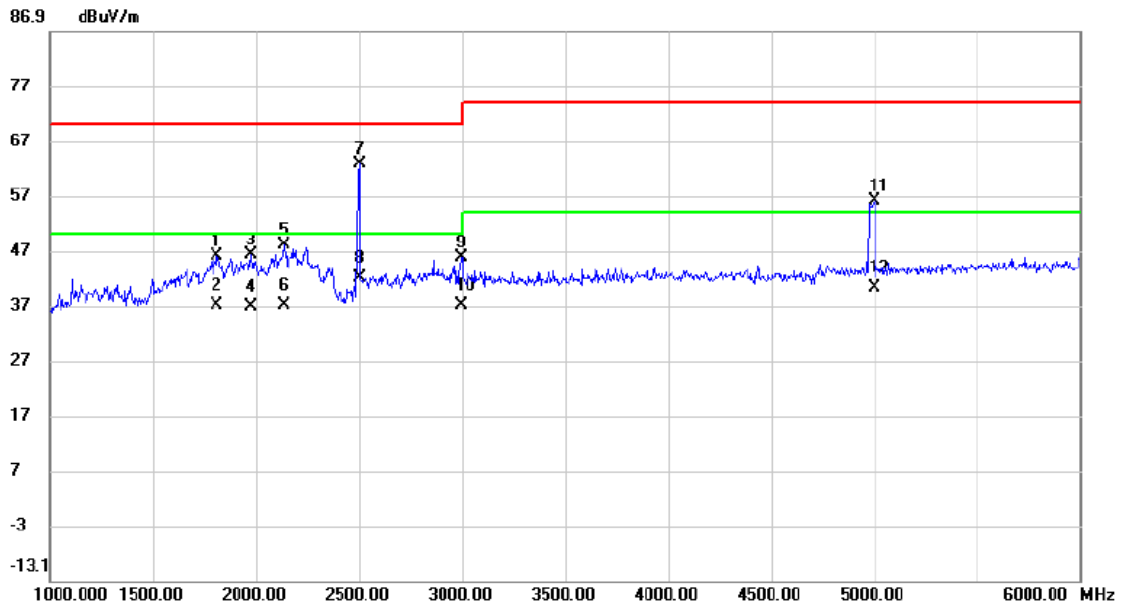

| No. | Mk. | Freq. MHz | Reading Level dBuV | Correct Factor dB | Measure- ment dBuV/m | Limit dBuV/m | Margin dB | Detector | Comment |
|-----|-----|--------------|--------------------------|-------------------------|----------------------------|-----------------|--------------|----------|---------|
| 1 | | 1810.000 | 47.07 | -1.05 | 46.02 | 70.00 | -23.98 | peak | |
| 2 | | 1810.000 | 38.02 | -1.05 | 36.97 | 50.00 | -13.03 | AVG | |
| 3 | | 1975.000 | 46.22 | 0.01 | 46.23 | 70.00 | -23.77 | peak | |
| 4 | | 1975.000 | 36.87 | 0.01 | 36.88 | 50.00 | -13.12 | AVG | |
| 5 | | 2137.500 | 47.32 | 0.68 | 48.00 | 70.00 | -22.00 | peak | |
| 6 | | 2137.500 | 36.45 | 0.68 | 37.13 | 50.00 | -12.87 | AVG | |
| 7 | * | 2500.000 | 60.81 | 2.02 | 62.83 | 70.00 | -7.17 | peak | |
| 8 | | 2500.000 | 40.11 | 2.02 | 42.13 | 50.00 | -7.87 | AVG | |
| 9 | | 2995.000 | 41.60 | 4.23 | 45.83 | 70.00 | -24.17 | peak | |
| 10 | | 2995.000 | 32.70 | 4.23 | 36.93 | 50.00 | -13.07 | AVG | |
| 11 | | 5000.000 | 45.88 | 10.09 | 55.97 | 74.00 | -18.03 | peak | |
| 12 | | 5000.000 | 30.12 | 10.09 | 40.21 | 54.00 | -13.79 | AVG | |

| | | | |
|--------------|--------------|--------------|------------|
| Test Voltage | AC 230V/50Hz | Polarization | Horizontal |
| Test Mode | Mode 11 | | |

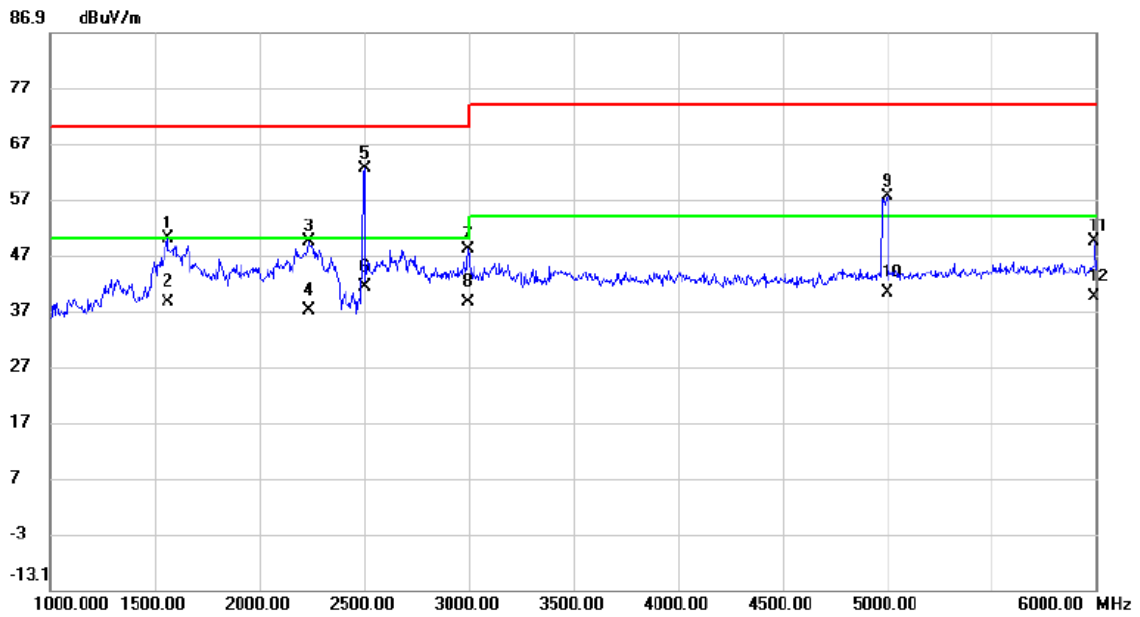

| No. | Mk. | Freq. MHz | Reading Level dBuV | Correct Factor dB | Measure- ment dBuV/m | Limit dBuV/m | Margin dB | Detector | Comment |
|-----|-----|--------------|--------------------------|-------------------------|----------------------------|-----------------|--------------|----------|---------|
| 1 | | 1562.500 | 52.54 | -2.63 | 49.91 | 70.00 | -20.09 | peak | |
| 2 | | 1562.500 | 41.09 | -2.63 | 38.46 | 50.00 | -11.54 | AVG | |
| 3 | | 2237.500 | 48.46 | 1.05 | 49.51 | 70.00 | -20.49 | peak | |
| 4 | | 2237.500 | 35.92 | 1.05 | 36.97 | 50.00 | -13.03 | AVG | |
| 5 | * | 2500.000 | 60.45 | 2.02 | 62.47 | 70.00 | -7.53 | peak | |
| 6 | | 2500.000 | 39.18 | 2.02 | 41.20 | 50.00 | -8.80 | AVG | |
| 7 | | 2995.000 | 43.86 | 4.23 | 48.09 | 70.00 | -21.91 | peak | |
| 8 | | 2995.000 | 34.18 | 4.23 | 38.41 | 50.00 | -11.59 | AVG | |
| 9 | | 5000.000 | 47.40 | 10.09 | 57.49 | 74.00 | -16.51 | peak | |
| 10 | | 5000.000 | 30.14 | 10.09 | 40.23 | 54.00 | -13.77 | AVG | |
| 11 | | 5992.500 | 37.25 | 12.18 | 49.43 | 74.00 | -24.57 | peak | |
| 12 | | 5992.500 | 27.45 | 12.18 | 39.63 | 54.00 | -14.37 | AVG | |

| | | | |
|--------------|--------------|--------------|----------|
| Test Voltage | AC 110V/60Hz | Polarization | Vertical |
| Test Mode | Mode 1 | | |

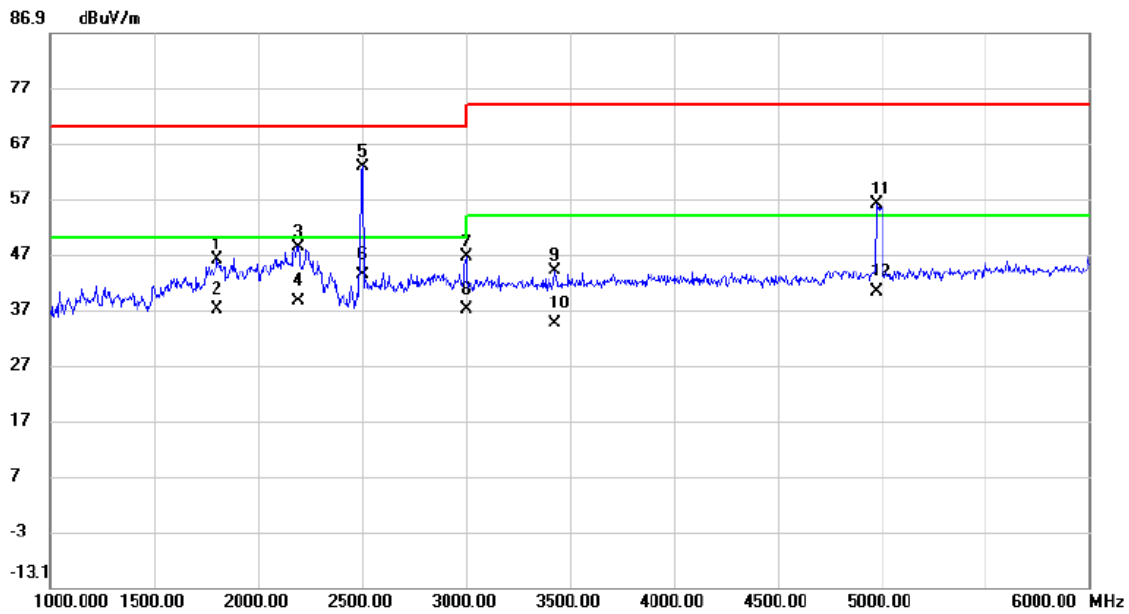

| No. | Mk. | Freq. MHz | Reading Level dBuV | Correct Factor dB | Measure- ment dBuV/m | Limit dBuV/m | Margin dB | Detector | Comment |
|-----|-----|--------------|--------------------------|-------------------------|----------------------------|-----------------|--------------|----------|---------|
| 1 | | 1805.000 | 47.10 | -1.08 | 46.02 | 70.00 | -23.98 | peak | |
| 2 | | 1805.000 | 38.04 | -1.08 | 36.96 | 50.00 | -13.04 | AVG | |
| 3 | | 2195.000 | 47.46 | 0.89 | 48.35 | 70.00 | -21.65 | peak | |
| 4 | | 2195.000 | 37.52 | 0.89 | 38.41 | 50.00 | -11.59 | AVG | |
| 5 | | 2500.000 | 60.69 | 2.02 | 62.71 | 70.00 | -7.29 | peak | |
| 6 | * | 2500.000 | 41.18 | 2.02 | 43.20 | 50.00 | -6.80 | AVG | |
| 7 | | 3000.000 | 42.16 | 4.25 | 46.41 | 70.00 | -23.59 | peak | |
| 8 | | 3000.000 | 32.68 | 4.25 | 36.93 | 50.00 | -13.07 | AVG | |
| 9 | | 3432.500 | 38.30 | 5.65 | 43.95 | 74.00 | -30.05 | peak | |
| 10 | | 3432.500 | 28.93 | 5.65 | 34.58 | 54.00 | -19.42 | AVG | |
| 11 | | 4977.500 | 46.06 | 10.03 | 56.09 | 74.00 | -17.91 | peak | |
| 12 | | 4977.500 | 30.18 | 10.03 | 40.21 | 54.00 | -13.79 | AVG | |

| | | | |
|--------------|--------------|--------------|------------|
| Test Voltage | AC 110V/60Hz | Polarization | Horizontal |
| Test Mode | Mode 1 | | |

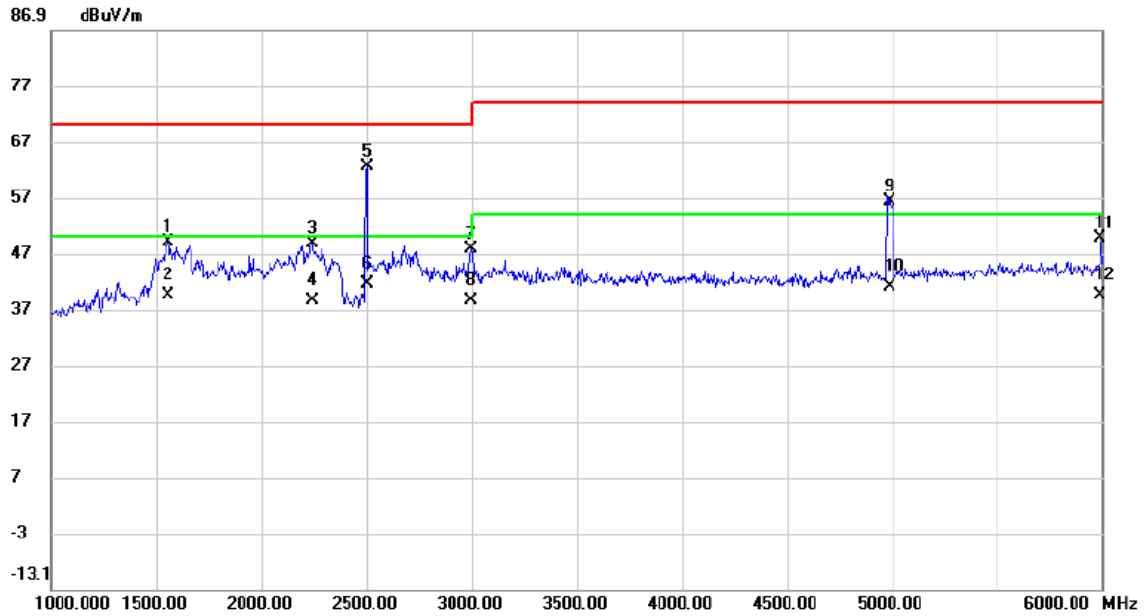

| No. | Mk. | Freq. MHz | Reading Level dBuV | Correct Factor dB | Measure- ment dBuV/m | Limit dBuV/m | Margin dB | Detector | Comment |
|-----|-----|--------------|--------------------------|-------------------------|----------------------------|-----------------|--------------|----------|---------|
| 1 | | 1555.000 | 51.75 | -2.67 | 49.08 | 70.00 | -20.92 | peak | |
| 2 | | 1555.000 | 42.19 | -2.67 | 39.52 | 50.00 | -10.48 | AVG | |
| 3 | | 2242.500 | 47.63 | 1.06 | 48.69 | 70.00 | -21.31 | peak | |
| 4 | | 2242.500 | 37.38 | 1.06 | 38.44 | 50.00 | -11.56 | AVG | |
| 5 | * | 2500.000 | 60.40 | 2.02 | 62.42 | 70.00 | -7.58 | peak | |
| 6 | | 2500.000 | 39.57 | 2.02 | 41.59 | 50.00 | -8.41 | AVG | |
| 7 | | 2995.000 | 43.57 | 4.23 | 47.80 | 70.00 | -22.20 | peak | |
| 8 | | 2995.000 | 34.40 | 4.23 | 38.63 | 50.00 | -11.37 | AVG | |
| 9 | | 4990.000 | 46.30 | 10.06 | 56.36 | 74.00 | -17.64 | peak | |
| 10 | | 4990.000 | 31.05 | 10.06 | 41.11 | 54.00 | -12.89 | AVG | |
| 11 | | 5992.500 | 37.70 | 12.18 | 49.88 | 74.00 | -24.12 | peak | |
| 12 | | 5992.500 | 27.35 | 12.18 | 39.53 | 54.00 | -14.47 | AVG | |

3.3 CONDUCTED EMISSION MEASUREMENT AT AC MAINS POWER PORTS

3.3.1 LIMITS

Requirements for conducted emissions from AC mains power ports of Class B equipment

| Frequency Range MHz | Coupling Device | Detector Type / bandwidth | Class B Limits (dB(μV)) |
|------------------------|--------------------|------------------------------|-----------------------------|
| 0.15 - 0.5 | AMN | Quasi Peak / 9 kHz | 66-56 |
| 0.5 - 5 | | | 56 |
| 5 - 30 | | | 60 |
| 0.15 - 0.5 | AMN | Average / 9 kHz | 56-46 |
| 0.5 - 5 | | | 46 |
| 5 - 30 | | | 50 |

NOTE:

(1) The test result calculated as following:

Measurement Value = Reading Level + Correct Factor

Correct Factor = Insertion Loss + Cable Loss + Attenuator Factor(if use)

Margin Level = Measurement Value – Limit Value

3.3.2 MEASUREMENT INSTRUMENTS LIST

| Item | Kind of Equipment | Manufacturer | Type No. | Series Model | Calibrated until |
|------|-----------------------------|--------------|--------------------------|--------------|------------------|
| 1 | 50Ω Terminator | SHX | TF2-3G-A | 8122901 | Feb. 27, 2022 |
| 2 | TWO-LINE V-NETWORK | R&S | ENV216 | 100526 | Nov. 04, 2021 |
| 3 | EMI Test Receiver | R&S | ESR3 | 101862 | Jul. 25, 2021 |
| 4 | Artificial-Mains Network | SCHWARZBECK | NSLK 8127 | 8127685 | Feb. 28, 2022 |
| 5 | Cable | N/A | RG400 | N/A(12m) | Mar. 09, 2022 |
| 6 | Measurement Software | Farad | EZ-EMC Ver.NB-03A1-01 | N/A | N/A |

Remark: "N/A" denotes no model name, serial no. or calibration specified.

All calibration period of equipment list is one year.

3.3.3 TEST PROCEDURE

- The EUT was placed 0.8 meters from the horizontal ground plane with EUT being connected to the power mains through a line impedance stabilization network (LISN). All other support equipments powered from additional LISN(s). The LISN provide 50 Ohm/ 50uH of coupling impedance for the measuring instrument.
- Interconnecting cables that hang closer than 40 cm to the ground plane shall be folded back and forth in the center forming a bundle 30 to 40 cm long.
- I/O cables that are not connected to a peripheral shall be bundled in the center. The end of the cable may be terminated, if required, using the correct terminating impedance. The overall length shall not exceed 1 m.
- LISN at least 80 cm from nearest part of EUT chassis.
- For the actual test configuration, please refer to the related Item –EUT Test Photos.

3.3.4 DEVIATION FROM TEST STANDARD

No deviation

3.3.5 TEST SETUP

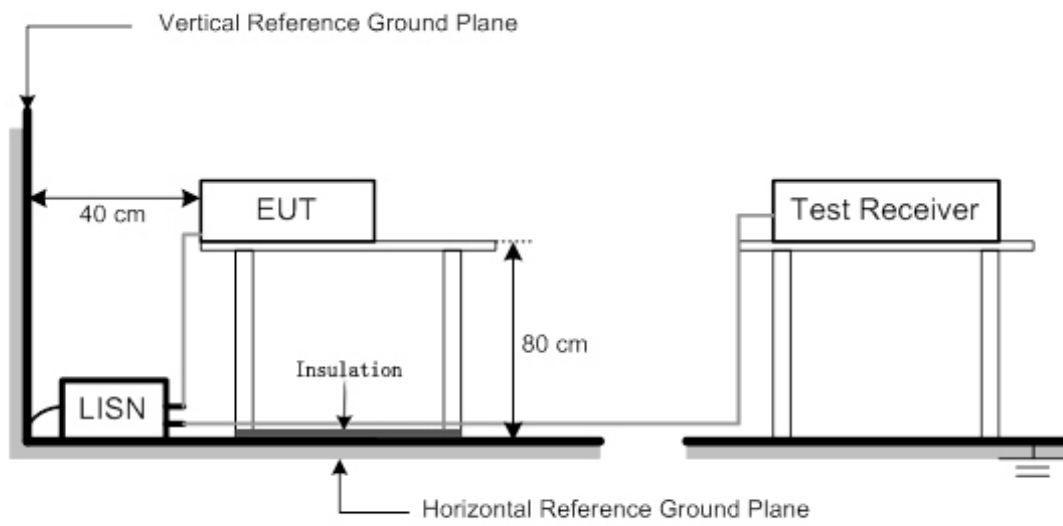

3.3.6 TEST RESULTS

| | | | |
|--------------|--------------|-------|------|
| Test Voltage | AC 230V/50Hz | Phase | Line |
| Test Mode | Mode 1 | | |

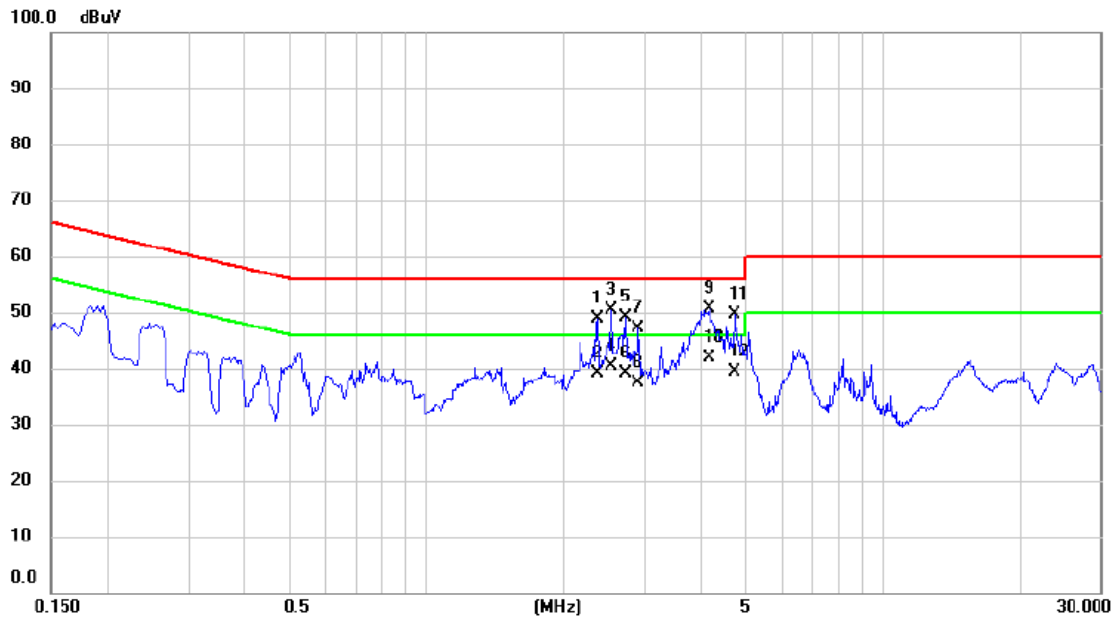

| No. | Mk. | Freq. MHz | Reading Level dBuV | Correct Factor dB | Measure- ment dBuV | Limit dBuV | Margin dB | Detector | Comment |
|-----|-----|--------------|--------------------------|-------------------------|--------------------------|---------------|--------------|----------|---------|
| 1 | | 2.3594 | 39.09 | 9.82 | 48.91 | 56.00 | -7.09 | QP | |
| 2 | | 2.3594 | 29.40 | 9.82 | 39.22 | 46.00 | -6.78 | AVG | |
| 3 | | 2.5440 | 40.51 | 9.83 | 50.34 | 56.00 | -5.66 | QP | |
| 4 | | 2.5440 | 30.60 | 9.83 | 40.43 | 46.00 | -5.57 | AVG | |
| 5 | | 2.7218 | 39.17 | 9.84 | 49.01 | 56.00 | -6.99 | QP | |
| 6 | | 2.7218 | 29.40 | 9.84 | 39.24 | 46.00 | -6.76 | AVG | |
| 7 | | 2.9063 | 37.25 | 9.86 | 47.11 | 56.00 | -8.89 | QP | |
| 8 | | 2.9063 | 27.40 | 9.86 | 37.26 | 46.00 | -8.74 | AVG | |
| 9 | | 4.1753 | 40.60 | 9.94 | 50.54 | 56.00 | -5.46 | QP | |
| 10 | * | 4.1753 | 31.98 | 9.94 | 41.92 | 46.00 | -4.08 | AVG | |
| 11 | | 4.7333 | 39.73 | 9.97 | 49.70 | 56.00 | -6.30 | QP | |
| 12 | | 4.7333 | 29.50 | 9.97 | 39.47 | 46.00 | -6.53 | AVG | |

| | | | |
|--------------|--------------|-------|---------|
| Test Voltage | AC 230V/50Hz | Phase | Neutral |
| Test Mode | Mode 1 | | |

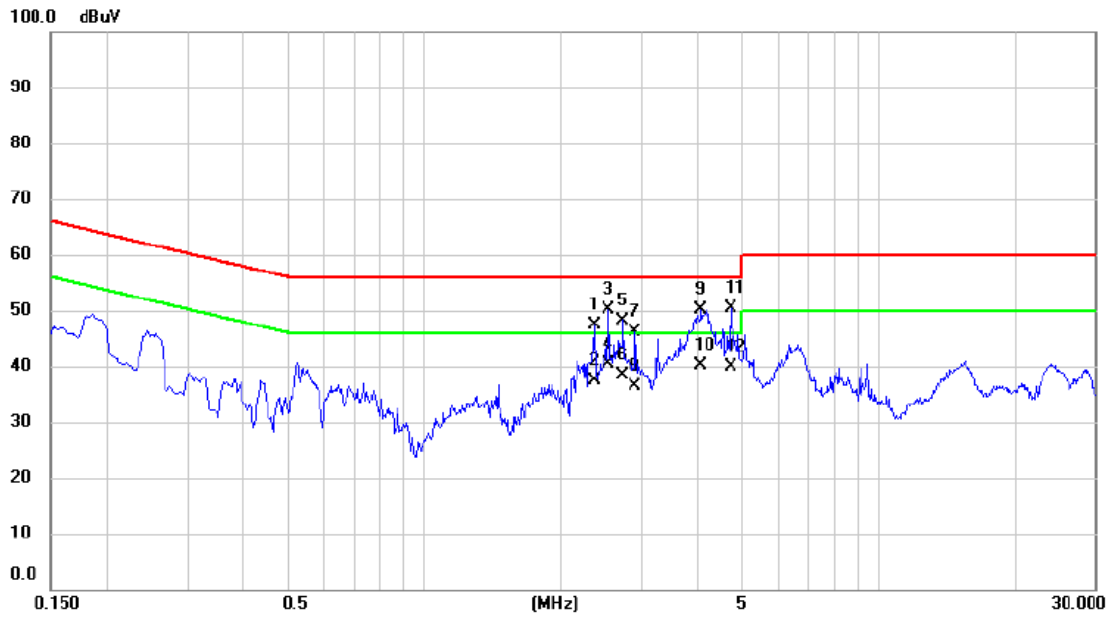

| No. | Mk. | Freq. MHz | Reading Level dBuV | Correct Factor dB | Measure- ment dBuV | Limit dBuV | Margin dB | Detector | Comment |
|-----|-----|--------------|--------------------------|-------------------------|--------------------------|---------------|--------------|----------|---------|
| 1 | | 2.3640 | 37.67 | 9.82 | 47.49 | 56.00 | -8.51 | QP | |
| 2 | | 2.3640 | 27.60 | 9.82 | 37.42 | 46.00 | -8.58 | AVG | |
| 3 | | 2.5463 | 40.25 | 9.83 | 50.08 | 56.00 | -5.92 | QP | |
| 4 | | 2.5463 | 30.50 | 9.83 | 40.33 | 46.00 | -5.67 | AVG | |
| 5 | | 2.7240 | 38.41 | 9.84 | 48.25 | 56.00 | -7.75 | QP | |
| 6 | | 2.7240 | 28.60 | 9.84 | 38.44 | 46.00 | -7.56 | AVG | |
| 7 | | 2.9108 | 36.18 | 9.86 | 46.04 | 56.00 | -9.96 | QP | |
| 8 | | 2.9108 | 26.40 | 9.86 | 36.26 | 46.00 | -9.74 | AVG | |
| 9 | | 4.0560 | 40.25 | 9.93 | 50.18 | 56.00 | -5.82 | QP | |
| 10 | | 4.0560 | 30.10 | 9.93 | 40.03 | 46.00 | -5.97 | AVG | |
| 11 | * | 4.7265 | 40.38 | 9.97 | 50.35 | 56.00 | -5.65 | QP | |
| 12 | | 4.7265 | 30.00 | 9.97 | 39.97 | 46.00 | -6.03 | AVG | |

| | | | |
|--------------|--------------|-------|------|
| Test Voltage | AC 230V/50Hz | Phase | Line |
| Test Mode | Mode 2 | | |

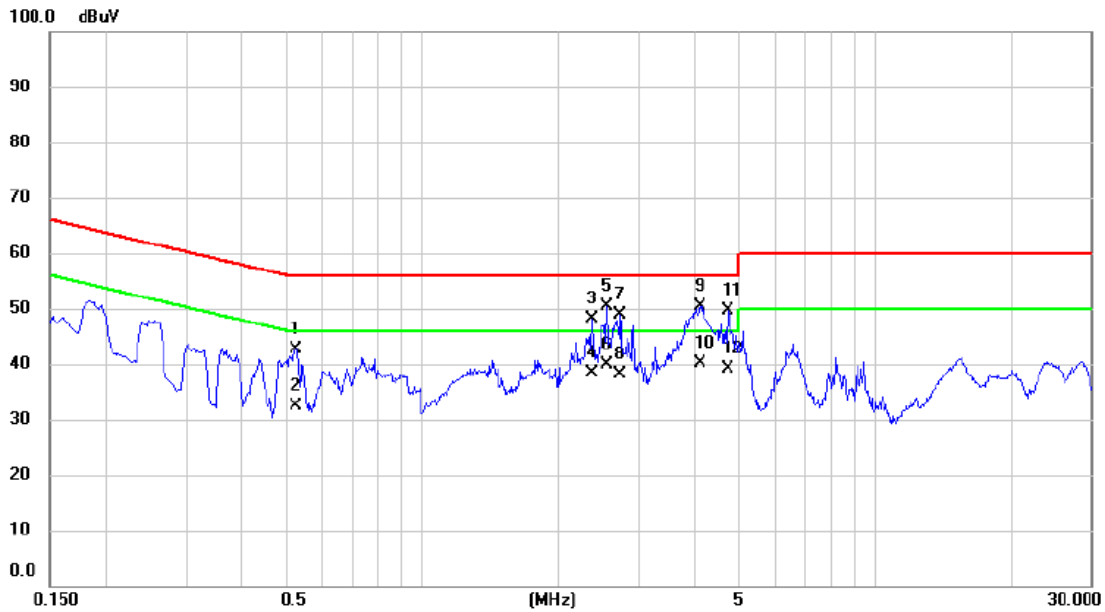

| No. | Mk. | Freq. MHz | Reading Level dBuV | Correct Factor dB | Measure- ment dBuV | Limit dBuV | Margin dB | Detector | Comment |
|-----|-----|--------------|--------------------------|-------------------------|--------------------------|---------------|--------------|----------|---------|
| 1 | | 0.5257 | 33.02 | 9.68 | 42.70 | 56.00 | -13.30 | QP | |
| 2 | | 0.5257 | 22.70 | 9.68 | 32.38 | 46.00 | -13.62 | AVG | |
| 3 | | 2.3685 | 38.38 | 9.82 | 48.20 | 56.00 | -7.80 | QP | |
| 4 | | 2.3685 | 28.60 | 9.82 | 38.42 | 46.00 | -7.58 | AVG | |
| 5 | | 2.5530 | 40.50 | 9.83 | 50.33 | 56.00 | -5.67 | QP | |
| 6 | | 2.5530 | 30.10 | 9.83 | 39.93 | 46.00 | -6.07 | AVG | |
| 7 | | 2.7308 | 39.00 | 9.84 | 48.84 | 56.00 | -7.16 | QP | |
| 8 | | 2.7308 | 28.40 | 9.84 | 38.24 | 46.00 | -7.76 | AVG | |
| 9 | * | 4.1055 | 40.57 | 9.93 | 50.50 | 56.00 | -5.50 | QP | |
| 10 | | 4.1055 | 30.30 | 9.93 | 40.23 | 46.00 | -5.77 | AVG | |
| 11 | | 4.7355 | 39.60 | 9.97 | 49.57 | 56.00 | -6.43 | QP | |
| 12 | | 4.7355 | 29.10 | 9.97 | 39.07 | 46.00 | -6.93 | AVG | |

| | | | |
|--------------|--------------|-------|---------|
| Test Voltage | AC 230V/50Hz | Phase | Neutral |
| Test Mode | Mode 2 | | |

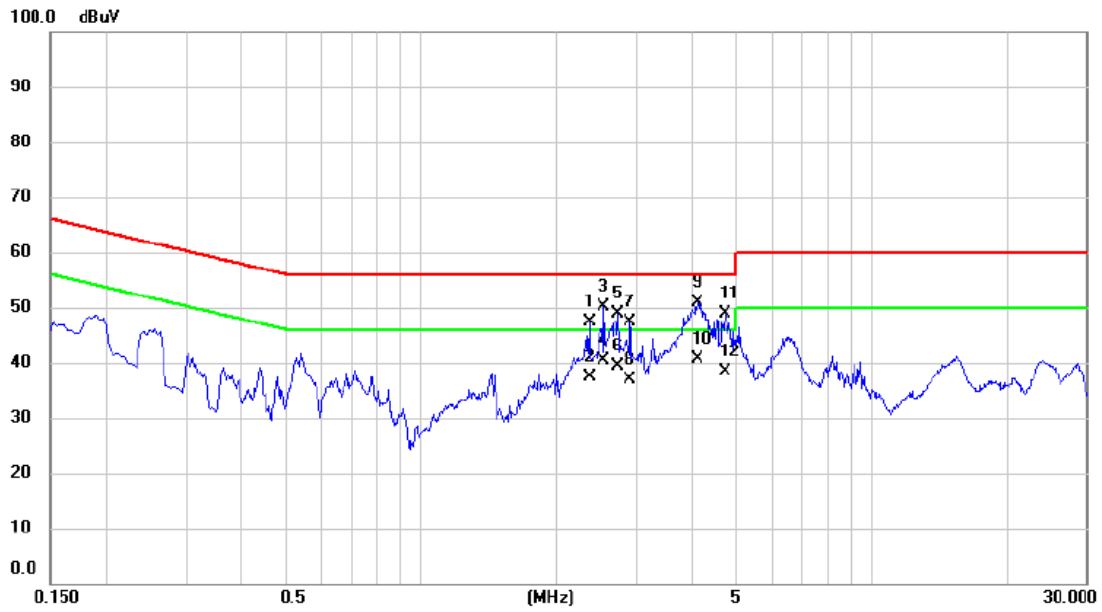

| No. | Mk. | Freq. MHz | Reading Level dBuV | Correct Factor dB | Measure- ment dBuV | Limit dBuV | Margin dB | Detector | Comment |
|-----|-----|--------------|--------------------------|-------------------------|--------------------------|---------------|--------------|----------|---------|
| 1 | | 2.3640 | 37.54 | 9.82 | 47.36 | 56.00 | -8.64 | QP | |
| 2 | | 2.3640 | 27.60 | 9.82 | 37.42 | 46.00 | -8.58 | AVG | |
| 3 | | 2.5485 | 40.37 | 9.83 | 50.20 | 56.00 | -5.80 | QP | |
| 4 | | 2.5485 | 30.50 | 9.83 | 40.33 | 46.00 | -5.67 | AVG | |
| 5 | | 2.7285 | 39.01 | 9.84 | 48.85 | 56.00 | -7.15 | QP | |
| 6 | | 2.7285 | 29.50 | 9.84 | 39.34 | 46.00 | -6.66 | AVG | |
| 7 | | 2.9130 | 37.43 | 9.86 | 47.29 | 56.00 | -8.71 | QP | |
| 8 | | 2.9130 | 27.10 | 9.86 | 36.96 | 46.00 | -9.04 | AVG | |
| 9 | * | 4.1033 | 40.83 | 9.93 | 50.76 | 56.00 | -5.24 | QP | |
| 10 | | 4.1033 | 30.60 | 9.93 | 40.53 | 46.00 | -5.47 | AVG | |
| 11 | | 4.7310 | 38.90 | 9.97 | 48.87 | 56.00 | -7.13 | QP | |
| 12 | | 4.7310 | 28.50 | 9.97 | 38.47 | 46.00 | -7.53 | AVG | |

| | | | |
|--------------|--------------|-------|------|
| Test Voltage | AC 230V/50Hz | Phase | Line |
| Test Mode | Mode 5 | | |

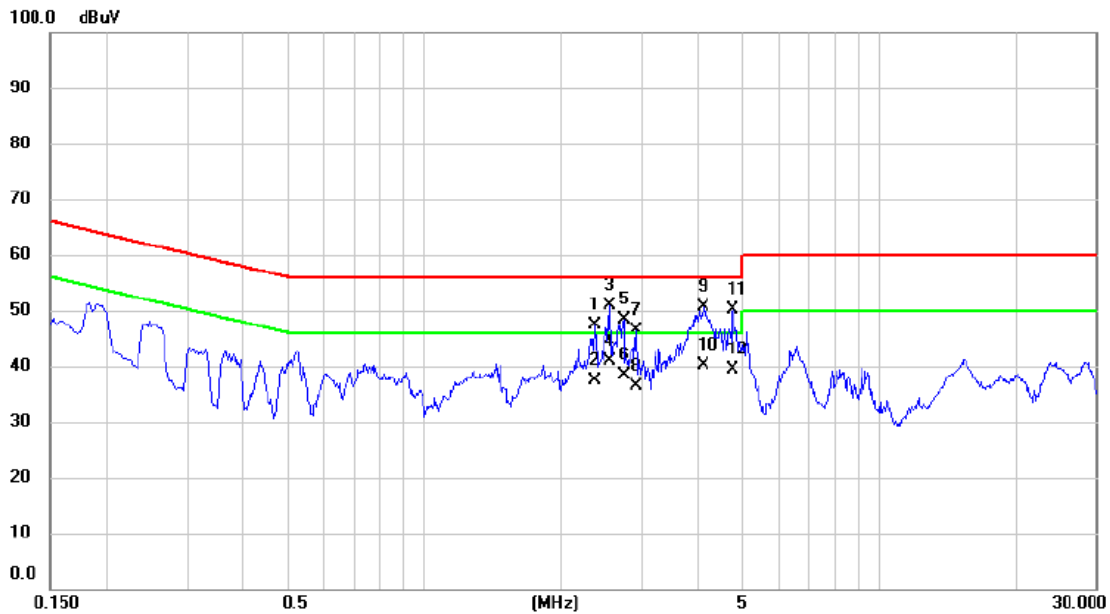

| No. | Mk. | Freq. MHz | Reading Level dBuV | Correct Factor dB | Measure- ment dBuV | Limit dBuV | Margin dB | Detector | Comment |
|-----|-----|--------------|--------------------------|-------------------------|--------------------------|---------------|--------------|----------|---------|
| 1 | | 2.3730 | 37.45 | 9.82 | 47.27 | 56.00 | -8.73 | QP | |
| 2 | | 2.3730 | 27.60 | 9.82 | 37.42 | 46.00 | -8.58 | AVG | |
| 3 | * | 2.5574 | 41.02 | 9.83 | 50.85 | 56.00 | -5.15 | QP | |
| 4 | | 2.5574 | 31.00 | 9.83 | 40.83 | 46.00 | -5.17 | AVG | |
| 5 | | 2.7375 | 38.49 | 9.84 | 48.33 | 56.00 | -7.67 | QP | |
| 6 | | 2.7375 | 28.60 | 9.84 | 38.44 | 46.00 | -7.56 | AVG | |
| 7 | | 2.9198 | 36.41 | 9.87 | 46.28 | 56.00 | -9.72 | QP | |
| 8 | | 2.9198 | 26.40 | 9.87 | 36.27 | 46.00 | -9.73 | AVG | |
| 9 | | 4.1190 | 40.69 | 9.93 | 50.62 | 56.00 | -5.38 | QP | |
| 10 | | 4.1190 | 30.30 | 9.93 | 40.23 | 46.00 | -5.77 | AVG | |
| 11 | | 4.7468 | 40.10 | 9.97 | 50.07 | 56.00 | -5.93 | QP | |
| 12 | | 4.7468 | 29.40 | 9.97 | 39.37 | 46.00 | -6.63 | AVG | |

| | | | |
|--------------|--------------|-------|---------|
| Test Voltage | AC 230V/50Hz | Phase | Neutral |
| Test Mode | Mode 5 | | |

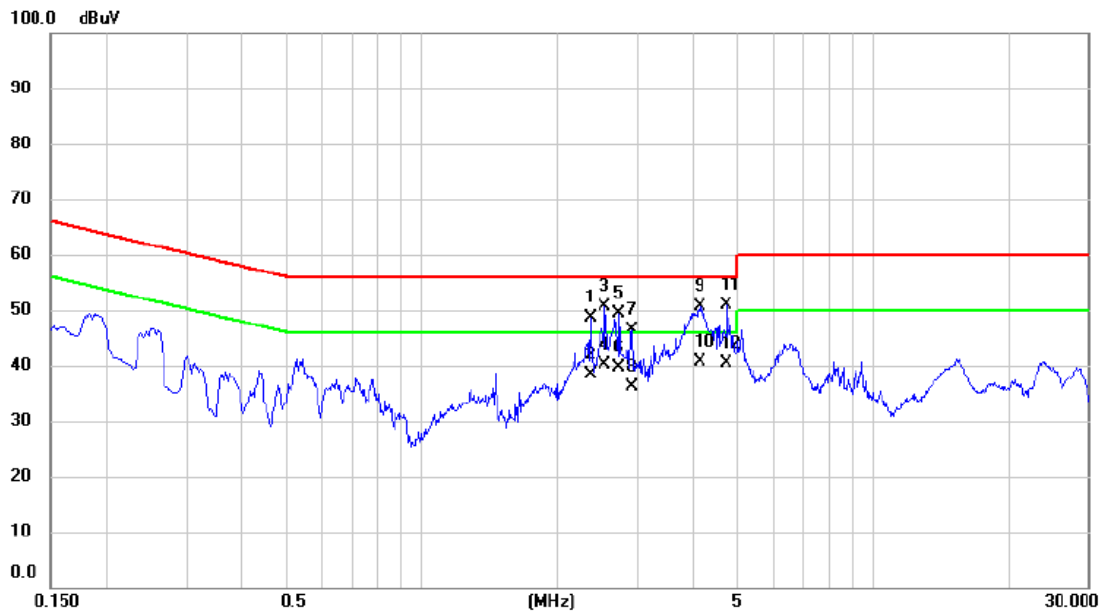

| No. | Mk. | Freq. MHz | Reading Level dBuV | Correct Factor dB | Measure- ment dBuV | Limit dBuV | Margin dB | Detector | Comment |
|-----|-----|--------------|--------------------------|-------------------------|--------------------------|---------------|--------------|----------|---------|
| 1 | | 2.3685 | 38.82 | 9.82 | 48.64 | 56.00 | -7.36 | QP | |
| 2 | | 2.3685 | 28.60 | 9.82 | 38.42 | 46.00 | -7.58 | AVG | |
| 3 | | 2.5485 | 40.68 | 9.83 | 50.51 | 56.00 | -5.49 | QP | |
| 4 | | 2.5485 | 30.40 | 9.83 | 40.23 | 46.00 | -5.77 | AVG | |
| 5 | | 2.7308 | 39.47 | 9.84 | 49.31 | 56.00 | -6.69 | QP | |
| 6 | | 2.7308 | 29.70 | 9.84 | 39.54 | 46.00 | -6.46 | AVG | |
| 7 | | 2.9153 | 36.58 | 9.86 | 46.44 | 56.00 | -9.56 | QP | |
| 8 | | 2.9153 | 26.30 | 9.86 | 36.16 | 46.00 | -9.84 | AVG | |
| 9 | | 4.1235 | 40.79 | 9.93 | 50.72 | 56.00 | -5.28 | QP | |
| 10 | | 4.1235 | 30.80 | 9.93 | 40.73 | 46.00 | -5.27 | AVG | |
| 11 | * | 4.7355 | 40.96 | 9.97 | 50.93 | 56.00 | -5.07 | QP | |
| 12 | | 4.7355 | 30.40 | 9.97 | 40.37 | 46.00 | -5.63 | AVG | |

| | | | |
|--------------|--------------|-------|------|
| Test Voltage | AC 110V/60Hz | Phase | Line |
| Test Mode | Mode 1 | | |

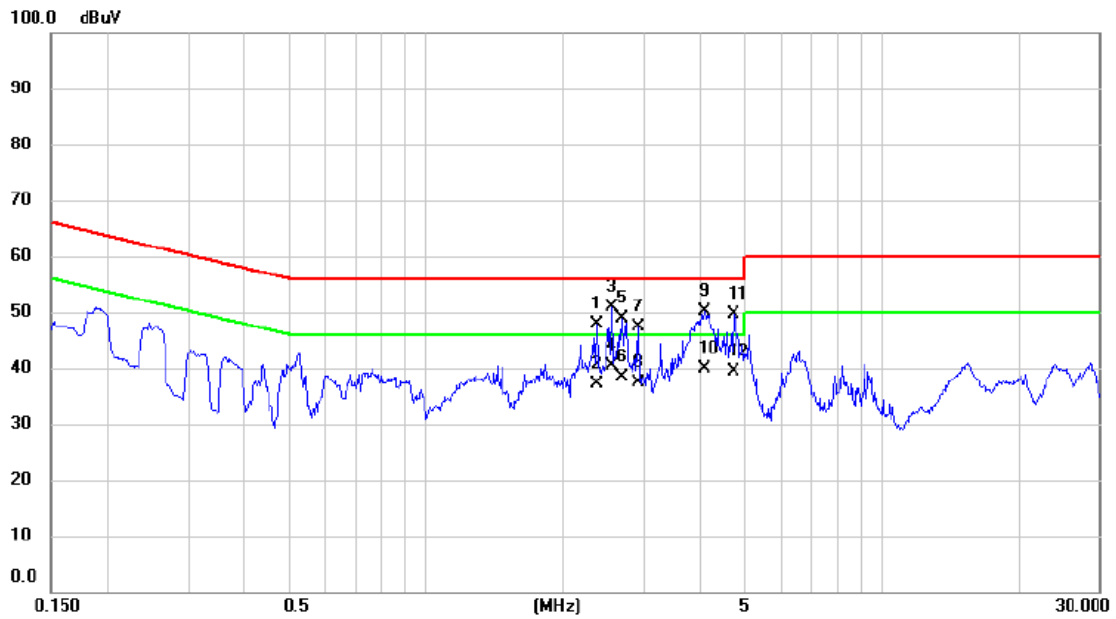

| No. | Mk. | Freq. MHz | Reading Level dBuV | Correct Factor dB | Measure- ment dBuV | Limit dBuV | Margin dB | Detector | Comment |
|-----|-----|--------------|--------------------------|-------------------------|--------------------------|---------------|--------------|----------|---------|
| 1 | | 2.3730 | 38.01 | 9.82 | 47.83 | 56.00 | -8.17 | QP | |
| 2 | | 2.3730 | 27.40 | 9.82 | 37.22 | 46.00 | -8.78 | AVG | |
| 3 | * | 2.5553 | 40.94 | 9.83 | 50.77 | 56.00 | -5.23 | QP | |
| 4 | | 2.5553 | 30.50 | 9.83 | 40.33 | 46.00 | -5.67 | AVG | |
| 5 | | 2.6903 | 39.09 | 9.84 | 48.93 | 56.00 | -7.07 | QP | |
| 6 | | 2.6903 | 28.60 | 9.84 | 38.44 | 46.00 | -7.56 | AVG | |
| 7 | | 2.9198 | 37.43 | 9.87 | 47.30 | 56.00 | -8.70 | QP | |
| 8 | | 2.9198 | 27.40 | 9.87 | 37.27 | 46.00 | -8.73 | AVG | |
| 9 | | 4.0875 | 40.21 | 9.93 | 50.14 | 56.00 | -5.86 | QP | |
| 10 | | 4.0875 | 29.90 | 9.93 | 39.83 | 46.00 | -6.17 | AVG | |
| 11 | | 4.7445 | 39.77 | 9.97 | 49.74 | 56.00 | -6.26 | QP | |
| 12 | | 4.7445 | 29.40 | 9.97 | 39.37 | 46.00 | -6.63 | AVG | |

| | | | |
|--------------|--------------|-------|---------|
| Test Voltage | AC 110V/60Hz | Phase | Neutral |
| Test Mode | Mode 1 | | |

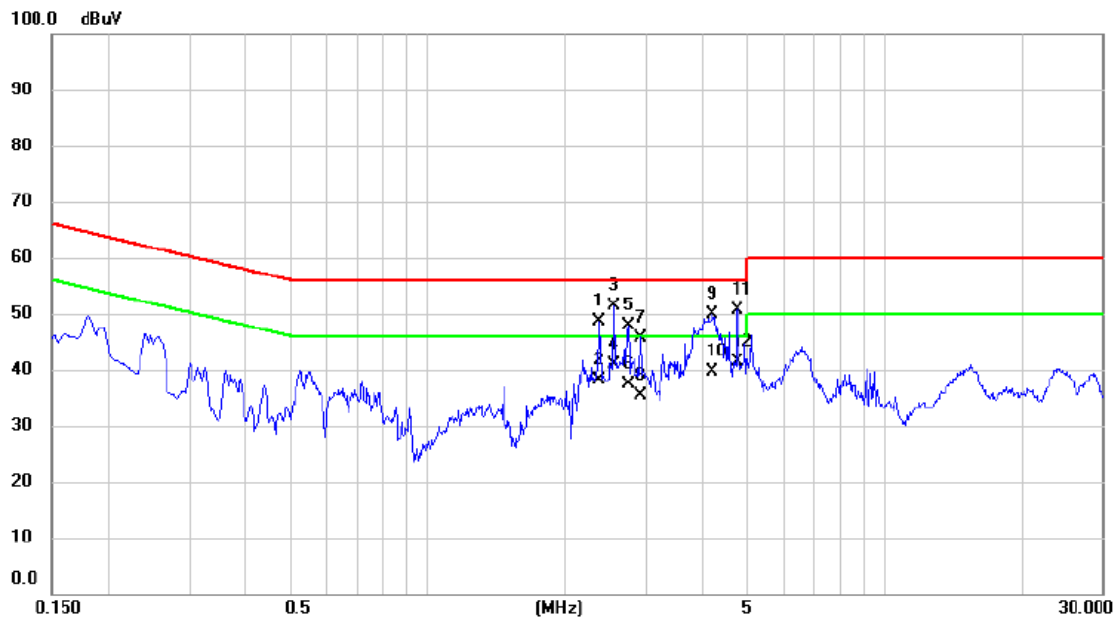

| No. | Mk. | Freq. MHz | Reading Level dBuV | Correct Factor dB | Measure- ment dBuV | Limit dBuV | Margin dB | Detector | Comment |
|-----|-----|--------------|--------------------------|-------------------------|--------------------------|---------------|--------------|----------|---------|
| 1 | | 2.3730 | 38.72 | 9.82 | 48.54 | 56.00 | -7.46 | QP | |
| 2 | | 2.3730 | 28.40 | 9.82 | 38.22 | 46.00 | -7.78 | AVG | |
| 3 | | 2.5553 | 41.43 | 9.83 | 51.26 | 56.00 | -4.74 | QP | |
| 4 | | 2.5553 | 31.10 | 9.83 | 40.93 | 46.00 | -5.07 | AVG | |
| 5 | | 2.7420 | 38.06 | 9.84 | 47.90 | 56.00 | -8.10 | QP | |
| 6 | | 2.7420 | 27.60 | 9.84 | 37.44 | 46.00 | -8.56 | AVG | |
| 7 | | 2.9198 | 35.88 | 9.87 | 45.75 | 56.00 | -10.25 | QP | |
| 8 | | 2.9198 | 25.40 | 9.87 | 35.27 | 46.00 | -10.73 | AVG | |
| 9 | | 4.2045 | 39.85 | 9.94 | 49.79 | 56.00 | -6.21 | QP | |
| 10 | | 4.2045 | 29.60 | 9.94 | 39.54 | 46.00 | -6.46 | AVG | |
| 11 | | 4.7468 | 40.78 | 9.97 | 50.75 | 56.00 | -5.25 | QP | |
| 12 | * | 4.7468 | 31.50 | 9.97 | 41.47 | 46.00 | -4.53 | AVG | |

4. EMC EMISSION TEST- EN 55032:2015+A11:2020

4.1 RADIATED EMISSIONS UP TO 1 GHZ

4.1.1 LIMITS

Class B equipment up to 1000MHz

| Frequency Range MHz | Measurement | | | Class B limits dB(μV/m) |
|------------------------|-------------|---------------|-----------------------------|----------------------------|
| | Facility | Distance m | Detector type/ bandwidth | |
| 30 - 230 | SAC | 10 | Quasi peak / 120 kHz | 30 |
| 230 - 1000 | | | | 37 |

Notes:

- (1) The limit for radiated test was performed according to as following: EN 55032
- (2) The tighter limit applies at the band edges.
- (3) Emission level (dBuV/m)=20log Emission level (uV/m).
- (4) The test result calculated as following:
 Measurement Value = Reading Level + Correct Factor
 Correct Factor = Antenna Factor + Cable Loss - Amplifier Gain(if use)
 Margin Level = Measurement Value - Limit Value

4.1.2 MEASUREMENT INSTRUMENTS LIST

| Item | Kind of Equipment | Manufacturer | Type No. | Series Model | Calibrated until |
|------|--------------------------|----------------|--------------------------|--------------|------------------|
| 1 | Receiver | Keysight | N9038A | MY54450004 | Jul. 25, 2021 |
| 2 | Pre-Amplifier | EMC INSTRUMENT | EMC 9135 | 980284 | Dec. 13, 2021 |
| 3 | Pre-Amplifier | EMC INSTRUMENT | EMC 9135 | 980283 | Dec. 13, 2021 |
| 4 | Trilog-Broadband Antenna | Schwarzbeck | VULB9168 | 946 | Oct. 16, 2021 |
| 5 | Trilog-Broadband Antenna | Schwarzbeck | VULB9168 | 947 | Nov. 09, 2021 |
| 6 | Cable | emci | LMR-400 (5m+8m+8m) | N/A | Jan. 06, 2022 |
| 7 | Measurement Software | Farad | EZ-EMC Ver.BTL-2ANT-1 | N/A | N/A |
| 8 | Multi-Device Controller | ETS-Lindgren | 2090 | N/A | N/A |
| 9 | Attenuator | EMCI | EMCI-N-6-06 | N0670 | Nov. 09, 2021 |
| 10 | Attenuator | EMCI | EMCI-N-6-06 | N0671 | Oct. 16, 2021 |

Remark: "N/A" denotes no model no., no serial no. or no calibration specified.

All calibration period of equipment list is one year.

4.1.3 TEST PROCEDURE

- The measuring distance of 10 m shall be used for measurements. The EUT was placed on the top of a rotating table 0.8 meter above the ground at a 10 meter semi-anechoic chamber. The table was rotated 360 degrees to determine the position of the highest radiation.(below 1GHz).
- The height of the equipment or of the substitution antenna shall be 0.8 m, the height of the test antenna shall vary between 1 m to 4 m. Both horizontal and vertical polarizations of the antenna are set to make the measurement.
- The initial step in collecting radiated emission data is a receiver peak detector mode pre-scanning the measurement frequency range. Significant peaks are then marked and then Quasi Peak detector mode re-measured.
- All readings are Peak unless otherwise stated QP in column of Note. Peak denotes that the Peak reading compliance with the QP Limits and then QP Mode measurement didn't perform.
(below 1GHz)
- For the actual test configuration, please refer to the related Item - Block Diagram of system tested.

4.1.4 DEVIATION FROM TEST STANDARD

No deviation

4.1.5 TEST SETUP

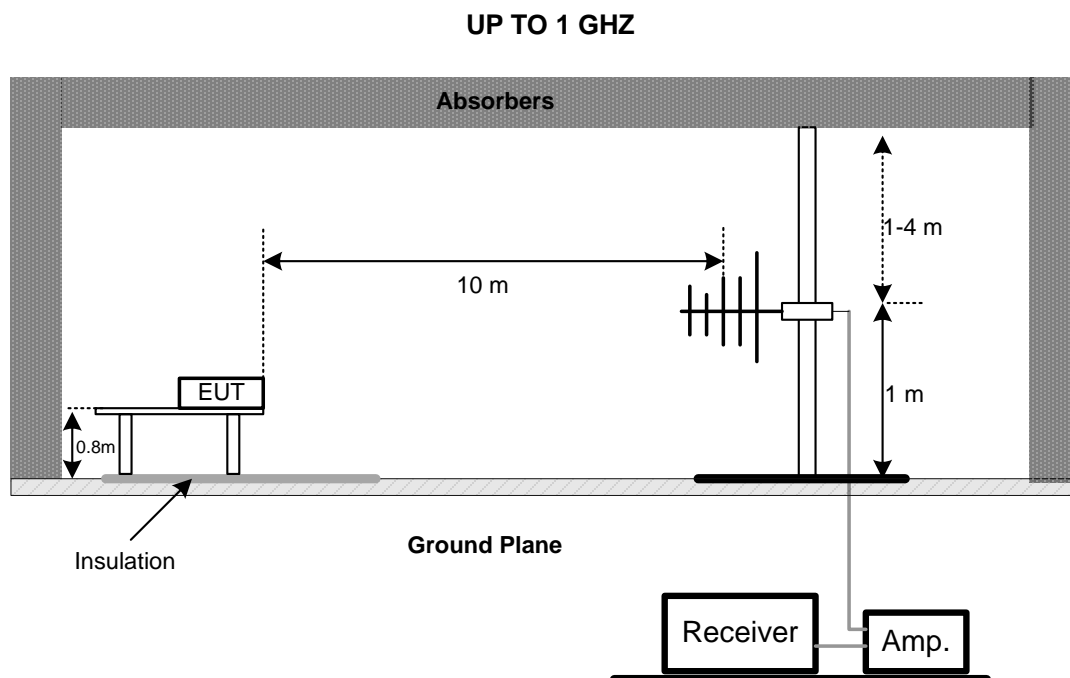

Note: The antenna can be moved between 1 to 4 meters above the ground.

4.1.6 MEASUREMENT DISTANCE

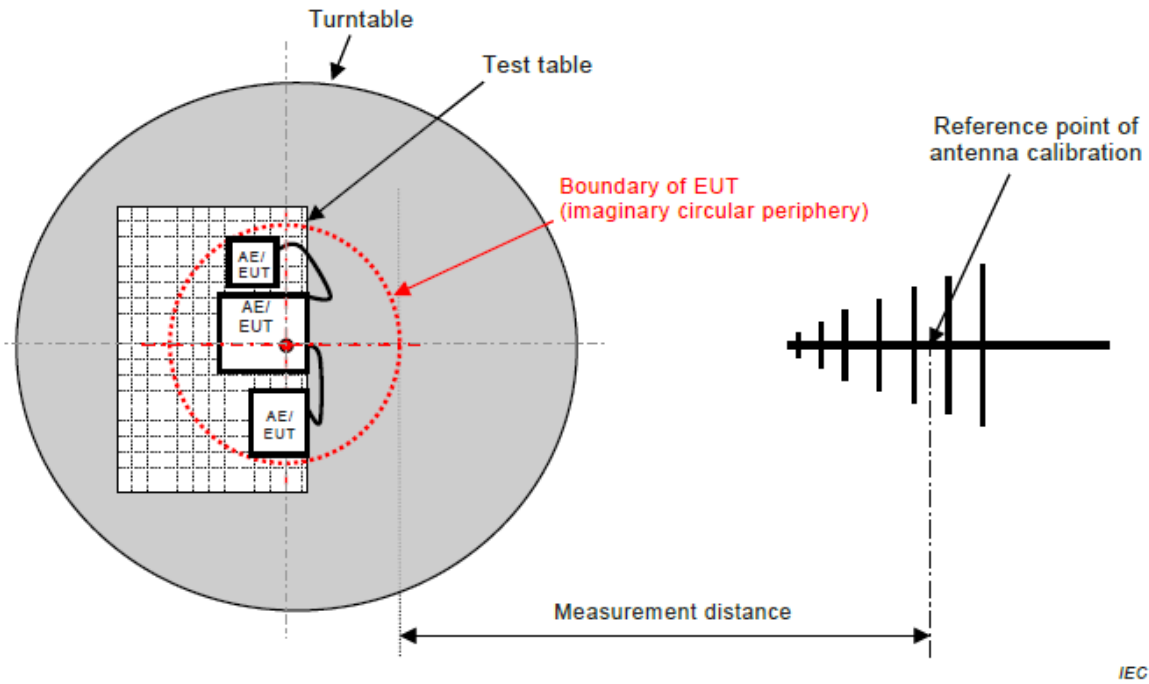

IEC

Figure C.1 – Measurement distance

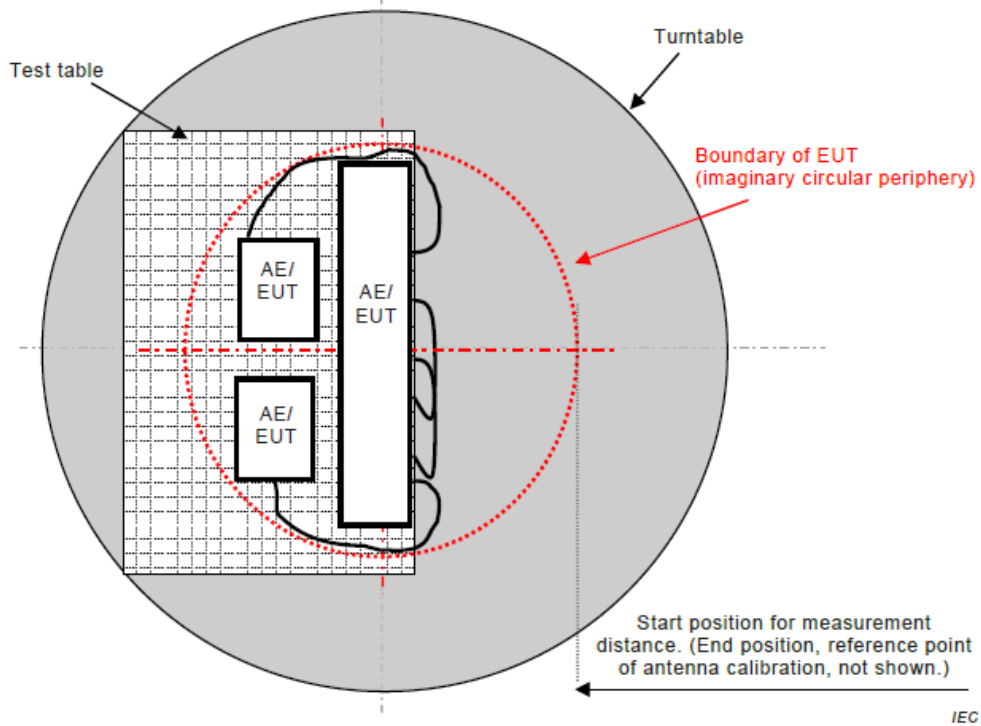

IEC

Figure C.2 – Boundary of EUT, Local AE and associated cabling

4.1.7 TEST RESULTS (UP TO 1 GHz)

| | | | |
|--------------|--------------|--------------|----------|
| Test Voltage | AC 230V/50Hz | Polarization | Vertical |
| Test Mode | Mode 1 | | |

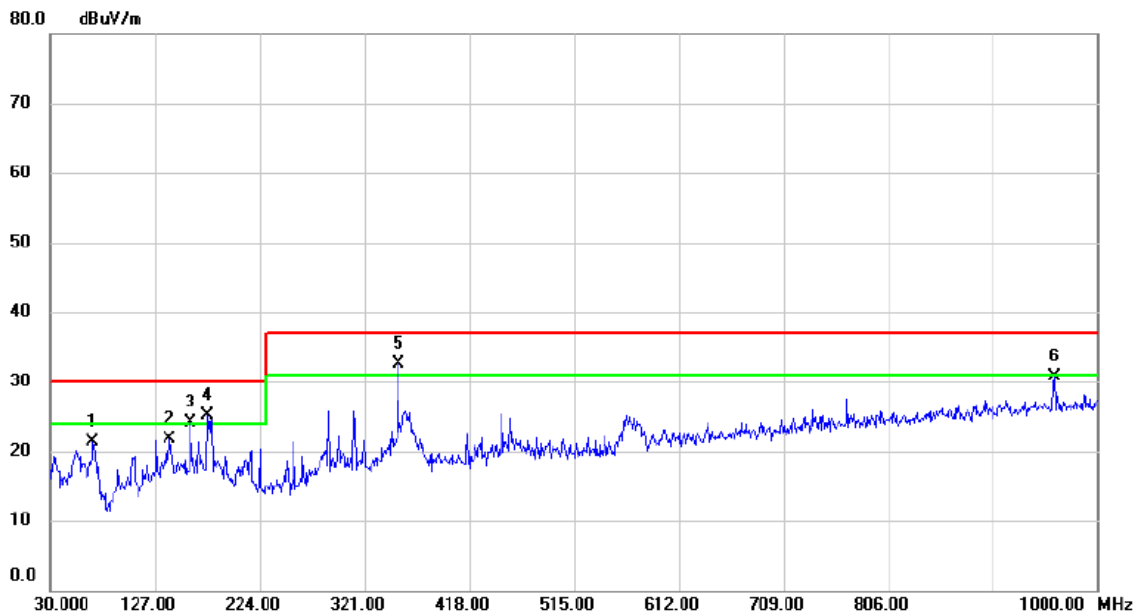

| No. Mk. | Freq. MHz | Reading Level dBuV | Correct Factor dB | Measure- ment dBuV/m | Limit dBuV/m | Margin dB | Detector | Comment |
|---------|--------------|--------------------------|-------------------------|----------------------------|-----------------|--------------|----------|---------|
| 1 | 69.7700 | 40.78 | -19.42 | 21.36 | 30.00 | -8.64 | QP | |
| 2 | 140.5800 | 39.17 | -17.50 | 21.67 | 30.00 | -8.33 | QP | |
| 3 ! | 159.9800 | 41.01 | -16.96 | 24.05 | 30.00 | -5.95 | QP | |
| 4 ! | 175.5000 | 42.93 | -17.75 | 25.18 | 30.00 | -4.82 | QP | |
| 5 * | 352.0400 | 46.68 | -14.23 | 32.45 | 37.00 | -4.55 | QP | |
| 6 | 960.2300 | 36.22 | -5.45 | 30.77 | 37.00 | -6.23 | QP | |

| | | | |
|--------------|--------------|--------------|------------|
| Test Voltage | AC 230V/50Hz | Polarization | Horizontal |
| Test Mode | Mode 1 | | |

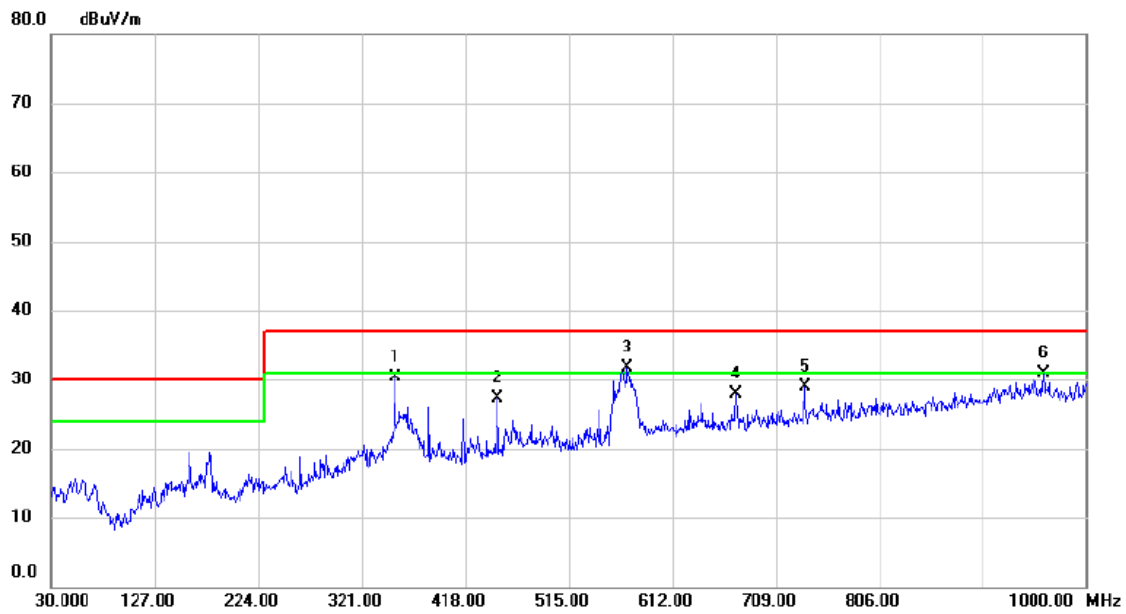

| No. | Mk. | Freq. MHz | Reading Level dBuV | Correct Factor dB | Measure- ment dBuV/m | Limit dBuV/m | Margin dB | Detector | Comment |
|-----|-----|--------------|--------------------------|-------------------------|----------------------------|-----------------|--------------|----------|---------|
| 1 | | 352.0400 | 44.20 | -13.84 | 30.36 | 37.00 | -6.64 | QP | |
| 2 | | 448.0700 | 38.63 | -11.34 | 27.29 | 37.00 | -9.71 | QP | |
| 3 | * | 570.2900 | 41.06 | -9.44 | 31.62 | 37.00 | -5.38 | QP | |
| 4 | | 672.1400 | 35.83 | -8.01 | 27.82 | 37.00 | -9.18 | QP | |
| 5 | | 736.1600 | 36.08 | -7.20 | 28.88 | 37.00 | -8.12 | QP | |
| 6 | | 960.2300 | 35.65 | -4.69 | 30.96 | 37.00 | -6.04 | QP | |

4.2 RADIATED EMISSIONS ABOVE 1 GHZ

4.2.1 LIMITS

Class B equipment above 1000MHz

| Frequency Range MHz | Measurement | | | Class B limits dB(μ V/m) |
|------------------------|-------------|---------------|----------------------------|----------------------------------|
| | Facility | Distance m | Detector type/bandwidth | |
| 1000 - 3000 | FSOATS | 3 | Average / 1 MHz | 50 |
| 3000 - 6000 | | | | 54 |
| 1000 - 3000 | | | Peak / 1 MHz | 70 |
| 3000 - 6000 | | | | 74 |

Notes:

- (1) The limit for radiated test was performed according to as following: EN 55032
- (2) The tighter limit applies at the band edges.
- (3) Emission level (dBuV/m)=20log Emission level (uV/m).
- (4) The test result calculated as following:
 Measurement Value = Reading Level + Correct Factor
 Correct Factor = Antenna Factor + Cable Loss - Amplifier Gain(if use)
 Margin Level = Measurement Value - Limit Value

Required highest frequency for radiated measurement

| Highest internal frequency (F_x) MHz | Highest measured frequency MHz |
|---|--|
| $F_x \leq 108$ | 1000 |
| $108 < F_x \leq 500$ | 2000 |
| $500 < F_x \leq 1000$ | 5000 |
| $F_x > 1000$ | 5 th up to a maximum 6 GHz, |

Note for FM and TV broadcast receiver, F_x is determined from the highest frequency generated or used excluding the local oscillator and tuned frequencies.

4.2.1 MEASUREMENT INSTRUMENTS LIST

| Item | Kind of Equipment | Manufacturer | Type No. | Series Model | Calibrated until |
|------|-------------------------|--------------|--------------------------|--------------|------------------|
| 1 | Horn Antenna | EMCO | 3115 | 9605-4803 | May 10, 2022 |
| 2 | Amplifier | Agilent | 8449B | 3008A02333 | Feb. 28, 2022 |
| 3 | MXE EMI Receiver | Agilent | N9038A | MY53220133 | Feb. 28, 2022 |
| 4 | Measurement Software | Farad | EZ-EMC Ver.BTL-2ANT-1 | N/A | N/A |
| 5 | Multi-Device Controller | ETS-Lindgren | 2090 | N/A | N/A |
| 6 | Controller | MF | MF-7802 | MF780208159 | N/A |
| 7 | Cable | Mlcable Inc. | B10-01-01-5M | 18047123 | Jan. 06, 2022 |
| 8 | Cable | Mlcable Inc. | B10-01-01-12M | 18072743 | Jan. 06, 2022 |
| 9 | Cable | RegalWay | RWLPS50-7.9A- SMSM-1M | 20200102 001 | Jan. 06, 2022 |

Remark: "N/A" denotes no model no., no serial no. or no calibration specified.

All calibration period of equipment list is one year.

4.2.1.1 TEST PROCEDURE

- The measuring distance of 3 m shall be used for measurements. The EUT was placed on the top of a rotating table 0.8 meter above the ground at a 10 meter semi-anechoic chamber. The table was rotated 360 degrees to determine the position of the highest radiation.
- The height of the equipment or of the substitution antenna shall be 0.8 m, the height of the test antenna shall vary between 1 m to 4 m. Both horizontal and vertical polarizations of the antenna are set to make the measurement.
- The initial step in collecting radiated emission data is a receiver peak detector mode pre-scanning the measurement frequency range. Significant peaks are then marked and then Quasi Peak detector mode re-measured.
- All readings are Peak Mode value unless otherwise stated AVG in column of Note. If the Peak Mode Measured value compliance with the Peak Limits and lower than AVG Limits, the EUT shall be deemed to meet both Peak & AVG Limits and then only Peak Mode was measured, but AVG Mode didn't perform. (above 1GHz)
- For the actual test configuration, please refer to the related Item - Block Diagram of system tested.

4.2.1.2 DEVIATION FROM TEST STANDARD

No deviation

4.2.1.3 TEST SETUP

ABOVE 1 GHz

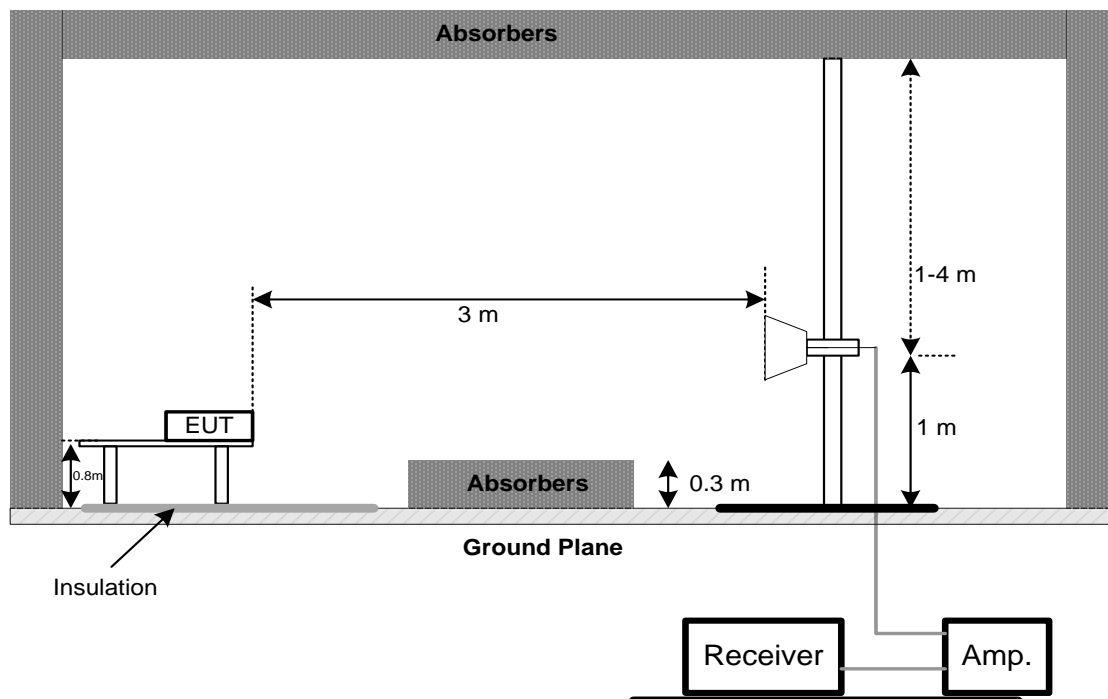

4.2.1.4 MEASUREMENT DISTANCE

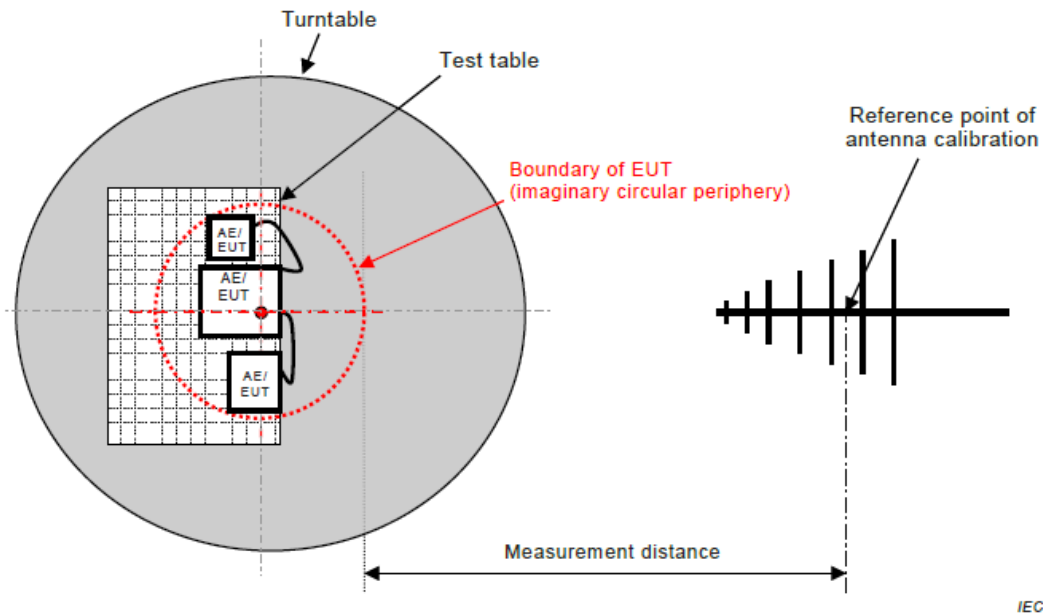

Figure C.1 – Measurement distance

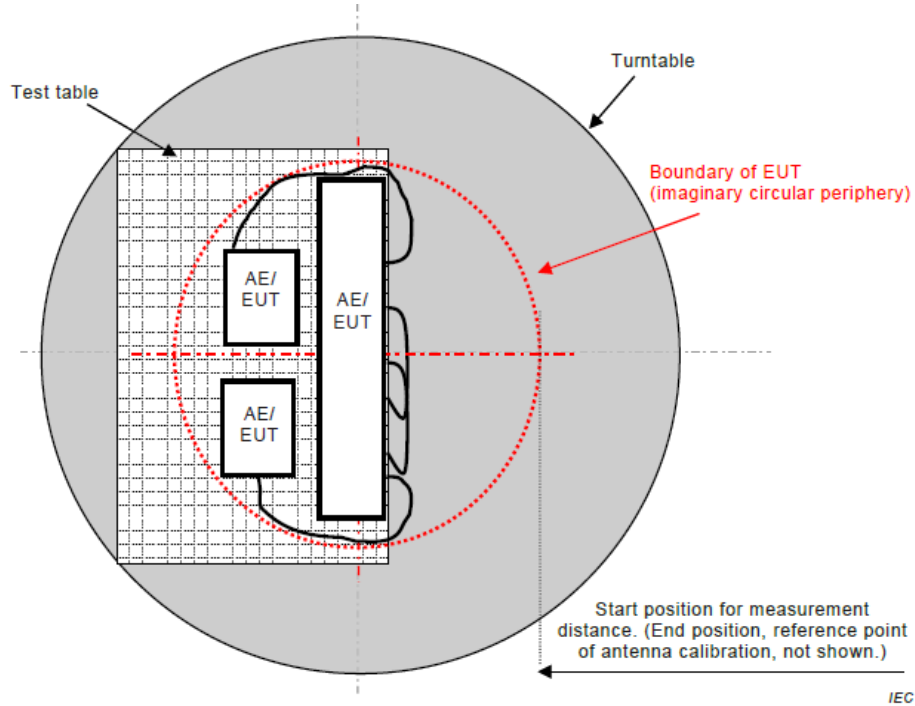
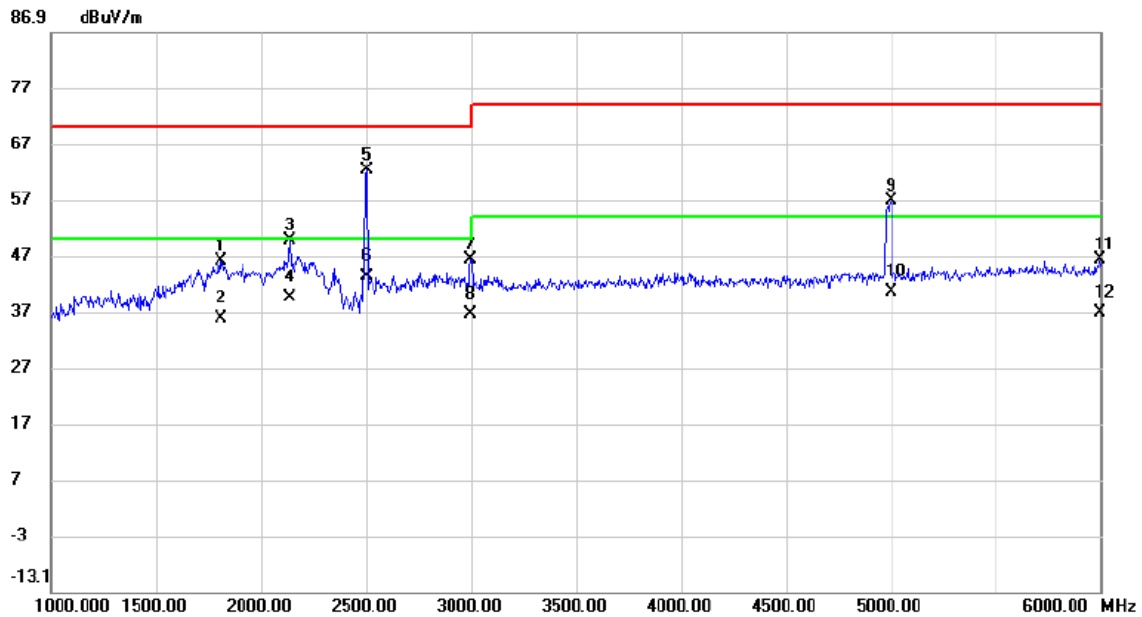

Figure C.2 – Boundary of EUT, Local AE and associated cabling

4.2.1.5 TEST RESULTS (ABOVE 1 GHZ)

| | | | |
|--------------|--------------|--------------|----------|
| Test Voltage | AC 230V/50Hz | Polarization | Vertical |
| Test Mode | Mode 1 | | |



| No. | Mk. | Freq. | Reading Level | Correct Factor | Measurement | Limit | Margin | Detector | Comment |
|-----|-----|----------|---------------|----------------|-------------|--------|--------|----------|---------|
| | | MHz | dBuV | dB | dBuV/m | dBuV/m | dB | | |
| 1 | | 1807.500 | 47.05 | -1.06 | 45.99 | 70.00 | -24.01 | peak | |
| 2 | | 1807.500 | 36.84 | -1.06 | 35.78 | 50.00 | -14.22 | AVG | |
| 3 | | 2135.000 | 49.16 | 0.67 | 49.83 | 70.00 | -20.17 | peak | |
| 4 | | 2135.000 | 38.97 | 0.67 | 39.64 | 50.00 | -10.36 | AVG | |
| 5 | | 2500.000 | 60.14 | 2.02 | 62.16 | 70.00 | -7.84 | peak | |
| 6 | * | 2500.000 | 41.18 | 2.02 | 43.20 | 50.00 | -6.80 | AVG | |
| 7 | | 2995.000 | 42.05 | 4.23 | 46.28 | 70.00 | -23.72 | peak | |
| 8 | | 2995.000 | 32.31 | 4.23 | 36.54 | 50.00 | -13.46 | AVG | |
| 9 | | 5000.000 | 46.67 | 10.09 | 56.76 | 74.00 | -17.24 | peak | |
| 10 | | 5000.000 | 30.46 | 10.09 | 40.55 | 54.00 | -13.45 | AVG | |
| 11 | | 5995.000 | 34.03 | 12.18 | 46.21 | 74.00 | -27.79 | peak | |
| 12 | | 5995.000 | 24.69 | 12.18 | 36.87 | 54.00 | -17.13 | AVG | |

| | | | |
|--------------|--------------|--------------|------------|
| Test Voltage | AC 230V/50Hz | Polarization | Horizontal |
| Test Mode | Mode 1 | | |

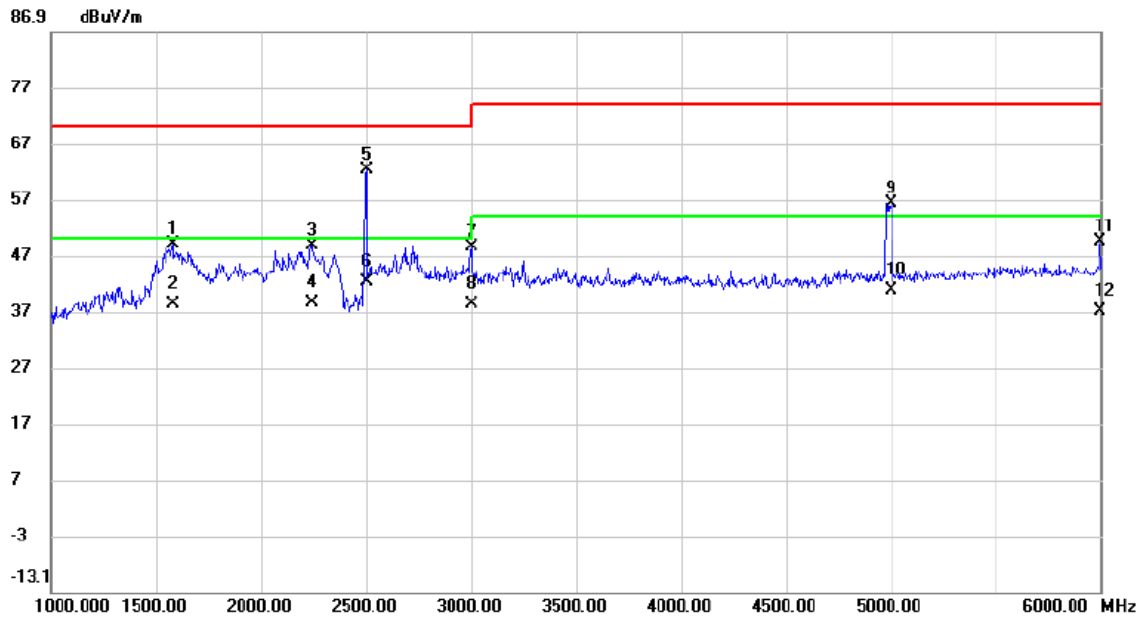

| No. | Mk. | Freq. MHz | Reading Level dBuV | Correct Factor dB | Measure- ment dBuV/m | Limit dBuV/m | Margin dB | Detector | Comment |
|-----|-----|--------------|--------------------------|-------------------------|----------------------------|-----------------|--------------|----------|---------|
| 1 | | 1582.500 | 51.41 | -2.49 | 48.92 | 70.00 | -21.08 | peak | |
| 2 | | 1582.500 | 40.80 | -2.49 | 38.31 | 50.00 | -11.69 | AVG | |
| 3 | | 2240.000 | 47.65 | 1.06 | 48.71 | 70.00 | -21.29 | peak | |
| 4 | | 2240.000 | 37.57 | 1.06 | 38.63 | 50.00 | -11.37 | AVG | |
| 5 | | 2500.000 | 60.18 | 2.02 | 62.20 | 70.00 | -7.80 | peak | |
| 6 | * | 2500.000 | 40.31 | 2.02 | 42.33 | 50.00 | -7.67 | AVG | |
| 7 | | 3000.000 | 44.29 | 4.25 | 48.54 | 70.00 | -21.46 | peak | |
| 8 | | 3000.000 | 33.91 | 4.25 | 38.16 | 50.00 | -11.84 | AVG | |
| 9 | | 5000.000 | 46.11 | 10.09 | 56.20 | 74.00 | -17.80 | peak | |
| 10 | | 5000.000 | 30.65 | 10.09 | 40.74 | 54.00 | -13.26 | AVG | |
| 11 | | 5995.000 | 37.29 | 12.18 | 49.47 | 74.00 | -24.53 | peak | |
| 12 | | 5995.000 | 24.79 | 12.18 | 36.97 | 54.00 | -17.03 | AVG | |

4.3 CONDUCTED EMISSION MEASUREMENT AT AC MAINS POWER PORTS

4.3.1 LIMITS

Requirements for conducted emissions from AC mains power ports of Class B equipment

| Frequency Range MHz | Coupling Device | Detector Type / bandwidth | Class B Limits (dB(μV)) |
|------------------------|--------------------|------------------------------|-----------------------------|
| 0.15 - 0.5 | AMN | Quasi Peak / 9 kHz | 66-56 |
| 0.5 - 5 | | | 56 |
| 5 - 30 | | | 60 |
| 0.15 - 0.5 | AMN | Average / 9 kHz | 56-46 |
| 0.5 - 5 | | | 46 |
| 5 - 30 | | | 50 |

NOTE:

(1) The test result calculated as following:

Measurement Value = Reading Level + Correct Factor

Correct Factor = Insertion Loss + Cable Loss + Attenuator Factor(if use)

Margin Level = Measurement Value – Limit Value

4.3.2 MEASUREMENT INSTRUMENTS LIST

| Item | Kind of Equipment | Manufacturer | Type No. | Series Model | Calibrated until |
|------|-----------------------------|--------------|--------------------------|--------------|------------------|
| 1 | 50Ω Terminator | SHX | TF2-3G-A | 8122901 | Feb. 27, 2022 |
| 2 | TWO-LINE V-NETWORK | R&S | ENV216 | 100526 | Nov. 04, 2021 |
| 3 | EMI Test Receiver | R&S | ESR3 | 101862 | Jul. 25, 2021 |
| 4 | Artificial-Mains Network | SCHWARZBECK | NSLK 8127 | 8127685 | Feb. 28, 2022 |
| 5 | Cable | N/A | RG400 | N/A(12m) | Mar. 09, 2022 |
| 6 | Measurement Software | Farad | EZ-EMC Ver.NB-03A1-01 | N/A | N/A |

Remark: "N/A" denotes no model name, serial no. or calibration specified.

All calibration period of equipment list is one year.

4.3.3 TEST PROCEDURE

- The EUT was placed 0.8 meters from the horizontal ground plane with EUT being connected to the power mains through a line impedance stabilization network (LISN). All other support equipments powered from additional LISN(s). The LISN provide 50 Ohm/ 50uH of coupling impedance for the measuring instrument.
- Interconnecting cables that hang closer than 40 cm to the ground plane shall be folded back and forth in the center forming a bundle 30 to 40 cm long.
- I/O cables that are not connected to a peripheral shall be bundled in the center. The end of the cable may be terminated, if required, using the correct terminating impedance. The overall length shall not exceed 1 m.
- LISN at least 80 cm from nearest part of EUT chassis.
- For the actual test configuration, please refer to the related Item –EUT Test Photos.

4.3.4 TEST SETUP

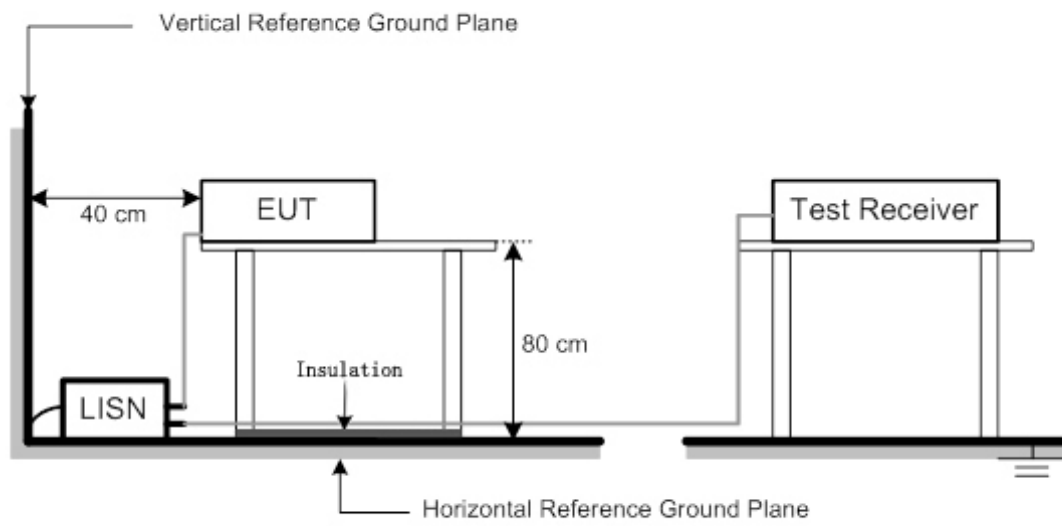

4.3.5 TEST RESULTS

| | | | |
|--------------|--------------|-------|------|
| Test Voltage | AC 230V/50Hz | Phase | Line |
| Test Mode | Mode 1 | | |

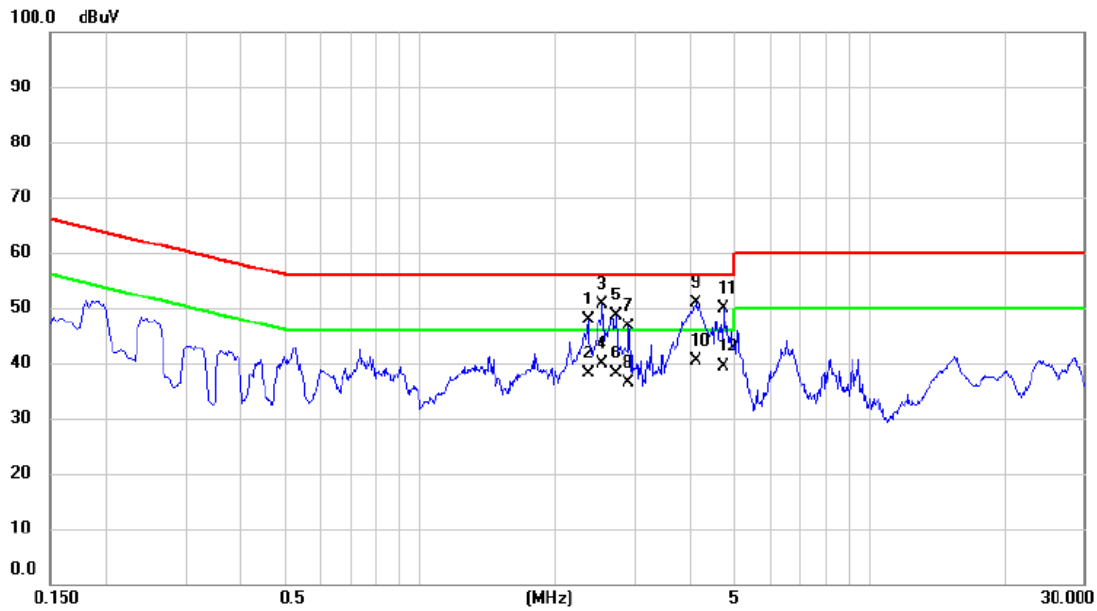

| No. | Mk. | Freq. MHz | Reading Level dBuV | Correct Factor dB | Measure- ment dBuV | Limit dBuV | Margin dB | Detector | Comment |
|-----|-----|--------------|--------------------------|-------------------------|--------------------------|---------------|--------------|----------|---------|
| 1 | | 2.3663 | 38.13 | 9.82 | 47.95 | 56.00 | -8.05 | QP | |
| 2 | | 2.3663 | 28.40 | 9.82 | 38.22 | 46.00 | -7.78 | AVG | |
| 3 | | 2.5485 | 40.80 | 9.83 | 50.63 | 56.00 | -5.37 | QP | |
| 4 | | 2.5485 | 30.10 | 9.83 | 39.93 | 46.00 | -6.07 | AVG | |
| 5 | | 2.7240 | 38.86 | 9.84 | 48.70 | 56.00 | -7.30 | QP | |
| 6 | | 2.7240 | 28.30 | 9.84 | 38.14 | 46.00 | -7.86 | AVG | |
| 7 | | 2.9130 | 36.65 | 9.86 | 46.51 | 56.00 | -9.49 | QP | |
| 8 | | 2.9130 | 26.40 | 9.86 | 36.26 | 46.00 | -9.74 | AVG | |
| 9 | * | 4.1190 | 40.91 | 9.93 | 50.84 | 56.00 | -5.16 | QP | |
| 10 | | 4.1190 | 30.40 | 9.93 | 40.33 | 46.00 | -5.67 | AVG | |
| 11 | | 4.7333 | 39.91 | 9.97 | 49.88 | 56.00 | -6.12 | QP | |
| 12 | | 4.7333 | 29.40 | 9.97 | 39.37 | 46.00 | -6.63 | AVG | |

| | | | |
|--------------|--------------|-------|---------|
| Test Voltage | AC 230V/50Hz | Phase | Neutral |
| Test Mode | Mode 1 | | |

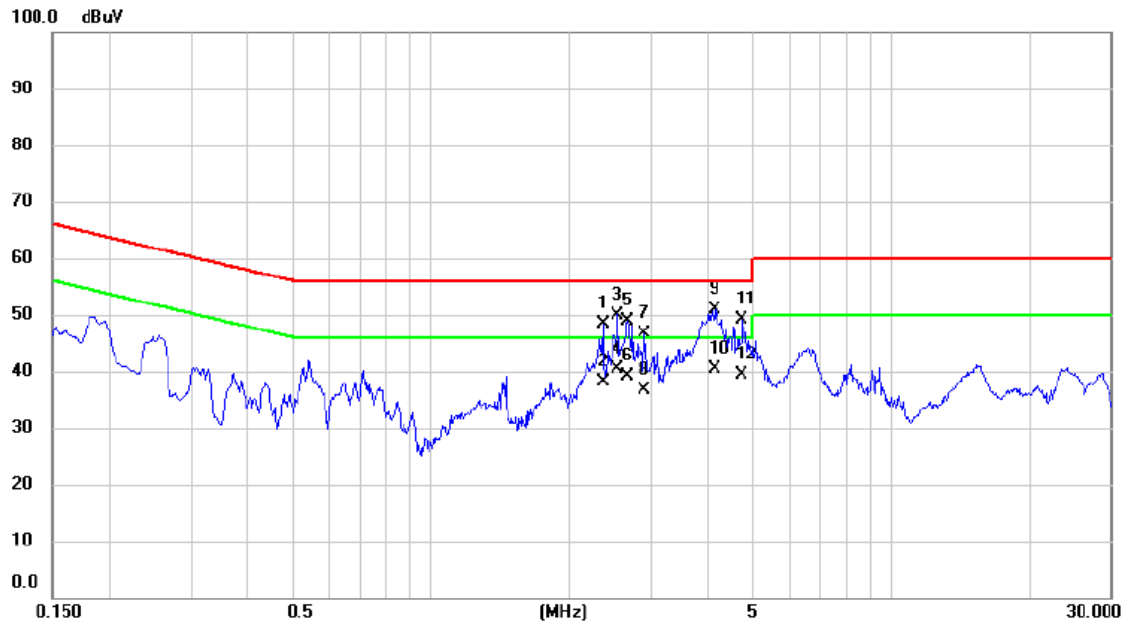

| No. | Mk. | Freq. MHz | Reading Level dBuV | Correct Factor dB | Measure- ment dBuV | Limit dBuV | Margin dB | Detector | Comment |
|-----|-----|--------------|--------------------------|-------------------------|--------------------------|---------------|--------------|----------|---------|
| 1 | | 2.3663 | 38.49 | 9.82 | 48.31 | 56.00 | -7.69 | QP | |
| 2 | | 2.3663 | 28.40 | 9.82 | 38.22 | 46.00 | -7.78 | AVG | |
| 3 | | 2.5463 | 40.17 | 9.83 | 50.00 | 56.00 | -6.00 | QP | |
| 4 | | 2.5463 | 30.60 | 9.83 | 40.43 | 46.00 | -5.57 | AVG | |
| 5 | | 2.6745 | 39.05 | 9.84 | 48.89 | 56.00 | -7.11 | QP | |
| 6 | | 2.6745 | 29.40 | 9.84 | 39.24 | 46.00 | -6.76 | AVG | |
| 7 | | 2.9085 | 36.83 | 9.86 | 46.69 | 56.00 | -9.31 | QP | |
| 8 | | 2.9085 | 26.70 | 9.86 | 36.56 | 46.00 | -9.44 | AVG | |
| 9 | * | 4.1235 | 40.91 | 9.93 | 50.84 | 56.00 | -5.16 | QP | |
| 10 | | 4.1235 | 30.50 | 9.93 | 40.43 | 46.00 | -5.57 | AVG | |
| 11 | | 4.7310 | 39.08 | 9.97 | 49.05 | 56.00 | -6.95 | QP | |
| 12 | | 4.7310 | 29.40 | 9.97 | 39.37 | 46.00 | -6.63 | AVG | |

5. HARMONIC AND FLICKER TEST

5.1 HARMONIC CURRENT EMISSIONS

5.1.1 LIMITS

The power consumption is less than 75W, there is no limit applied.

5.1.2 MEASUREMENT INSTRUMENTS LIST

| Item | Kind of Equipment | Manufacturer | Type No. | Series Model | Calibrated until |
|------|--------------------------------|------------------------|------------------------|--------------|------------------|
| 1 | Harmonics and Flicker Analyzer | California Instruments | PACS-1 | 72344 | Jul. 25, 2021 |
| 2 | 3KVA AC Power source | California Instruments | 3001ix | 56309 | Jul. 25, 2021 |
| 3 | Measurement Software | California | CTS4.0 Version 4.23 | N/A | N/A |

Remark: "N/A" denotes no model no., no serial No. or no calibration specified.

All calibration period of equipment list is one year.

5.1.3 TEST PROCEDURE

- The EUT was placed on the top of a wooden table 0.8 meters above the ground and operated to produce the maximum harmonic components under normal operating conditions.
- The correspondent test program of test instrument to measure the current harmonics emanated from EUT is chosen. The measure time shall be not less than the time necessary for the EUT to be exercised.

5.1.4 DEVIATION FROM TEST STANDARD

No deviation

5.1.5 TEST SETUP

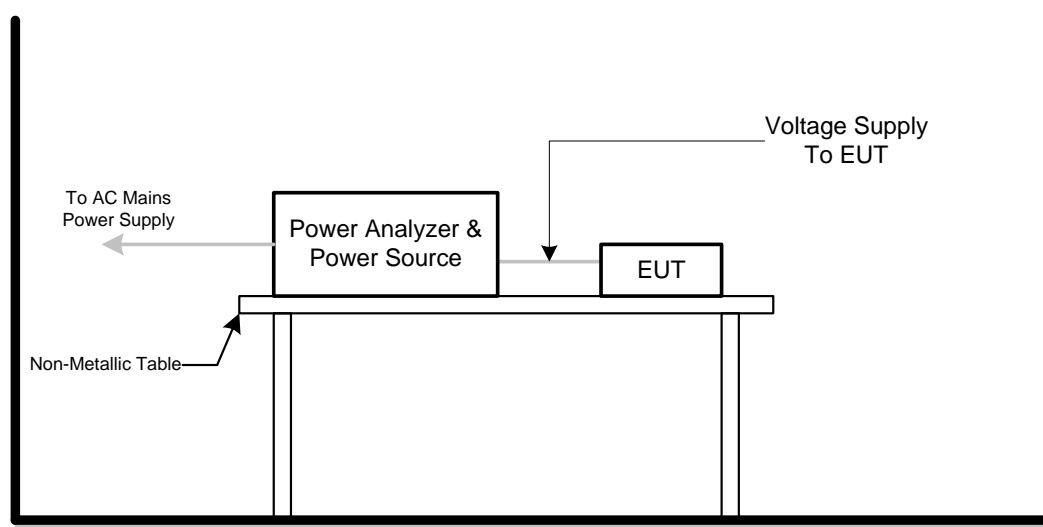

5.1.6 TEST RESULTS

| Harmonic - Class D | |
|--------------------|--------------|
| Test Voltage | AC 230V/50Hz |
| Test Mode | Mode 1 |

Current & voltage waveforms

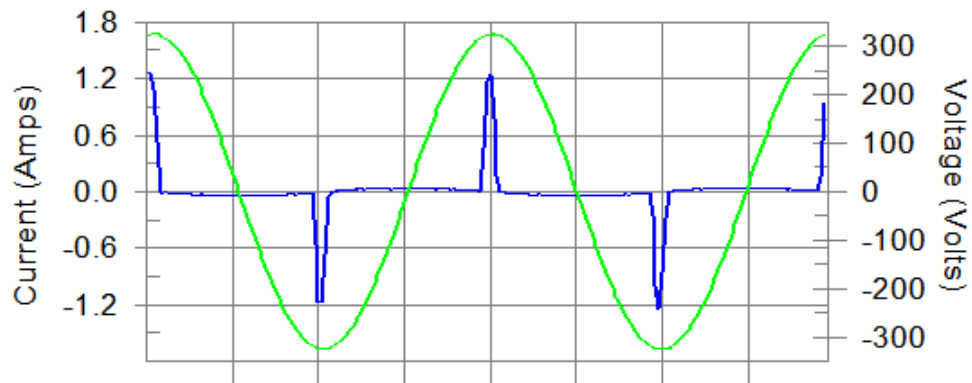

Harmonics and Class D limit line European Limits

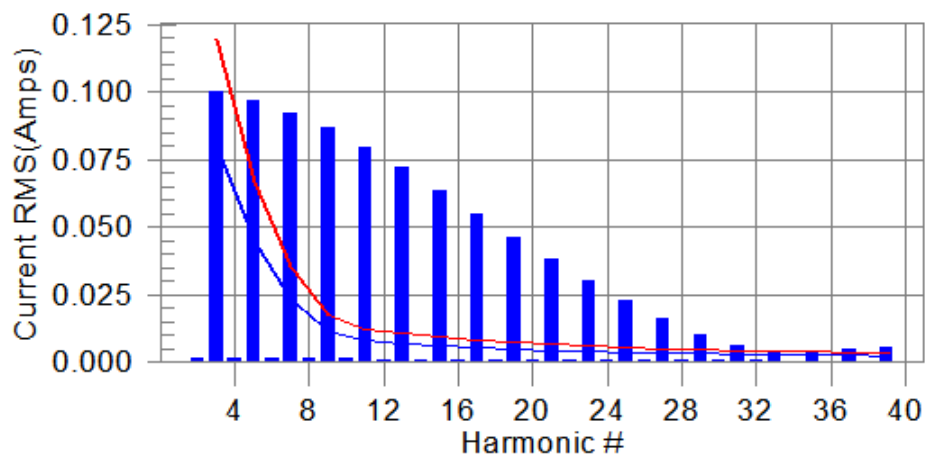

Test result: N/L Worst harmonics H0-0.0% of 150% limit, H0-0% of 100% limit

Current Test Result Summary (Run time)

| | |
|--------------|--------------|
| Test Voltage | AC 230V/50Hz |
| Test Mode | Mode 1 |

Highest parameter values during test:

| | | | |
|----------------|--------|----------------|-------|
| V RMS (Volts): | 229.95 | Frequency(Hz): | 50.00 |
| I Peak (Amps): | 1.301 | I RMS (Amps): | 0.268 |
| I Fund (Amps): | 0.109 | Crest Factor: | 4.875 |
| Power (Watts): | 23.5 | Power Factor: | 0.384 |

| Harm# | Harms(avg) | 100%Limit | %of Limit | Harms(max) | 150%Limit | %of Limit | Status |
|-------|------------|-----------|-----------|------------|-----------|-----------|--------|
| 2 | 0.001 | 0.000 | N/A | 0.002 | 0.000 | N/A | N/L |
| 3 | 0.100 | 0.080 | N/A | 0.102 | 0.120 | N/A | N/L |
| 4 | 0.002 | 0.000 | N/A | 0.002 | 0.000 | N/A | N/L |
| 5 | 0.097 | 0.045 | N/A | 0.097 | 0.067 | N/A | N/L |
| 6 | 0.001 | 0.000 | N/A | 0.002 | 0.000 | N/A | N/L |
| 7 | 0.093 | 0.024 | N/A | 0.093 | 0.035 | N/A | N/L |
| 8 | 0.001 | 0.000 | N/A | 0.002 | 0.000 | N/A | N/L |
| 9 | 0.087 | 0.012 | N/A | 0.087 | 0.018 | N/A | N/L |
| 10 | 0.001 | 0.000 | N/A | 0.002 | 0.000 | N/A | N/L |
| 11 | 0.080 | 0.008 | N/A | 0.080 | 0.012 | N/A | N/L |
| 12 | 0.001 | 0.000 | N/A | 0.001 | 0.000 | N/A | N/L |
| 13 | 0.072 | 0.007 | N/A | 0.072 | 0.011 | N/A | N/L |
| 14 | 0.001 | 0.000 | N/A | 0.001 | 0.000 | N/A | N/L |
| 15 | 0.064 | 0.006 | N/A | 0.064 | 0.009 | N/A | N/L |
| 16 | 0.001 | 0.000 | N/A | 0.001 | 0.000 | N/A | N/L |
| 17 | 0.055 | 0.005 | N/A | 0.055 | 0.008 | N/A | N/L |
| 18 | 0.001 | 0.000 | N/A | 0.001 | 0.000 | N/A | N/L |
| 19 | 0.046 | 0.005 | N/A | 0.046 | 0.007 | N/A | N/L |
| 20 | 0.001 | 0.000 | N/A | 0.001 | 0.000 | N/A | N/L |
| 21 | 0.038 | 0.004 | N/A | 0.038 | 0.006 | N/A | N/L |
| 22 | 0.001 | 0.000 | N/A | 0.001 | 0.000 | N/A | N/L |
| 23 | 0.030 | 0.004 | N/A | 0.030 | 0.006 | N/A | N/L |
| 24 | 0.001 | 0.000 | N/A | 0.001 | 0.000 | N/A | N/L |
| 25 | 0.022 | 0.004 | N/A | 0.023 | 0.005 | N/A | N/L |
| 26 | 0.000 | 0.000 | N/A | 0.001 | 0.000 | N/A | N/L |
| 27 | 0.016 | 0.003 | N/A | 0.016 | 0.005 | N/A | N/L |
| 28 | 0.000 | 0.000 | N/A | 0.001 | 0.000 | N/A | N/L |
| 29 | 0.010 | 0.003 | N/A | 0.010 | 0.005 | N/A | N/L |
| 30 | 0.000 | 0.000 | N/A | 0.001 | 0.000 | N/A | N/L |
| 31 | 0.006 | 0.003 | N/A | 0.006 | 0.004 | N/A | N/L |
| 32 | 0.000 | 0.000 | N/A | 0.001 | 0.000 | N/A | N/L |
| 33 | 0.004 | 0.003 | N/A | 0.004 | 0.004 | N/A | N/L |
| 34 | 0.000 | 0.000 | N/A | 0.001 | 0.000 | N/A | N/L |
| 35 | 0.004 | 0.003 | N/A | 0.004 | 0.004 | N/A | N/L |
| 36 | 0.000 | 0.000 | N/A | 0.001 | 0.000 | N/A | N/L |
| 37 | 0.005 | 0.002 | N/A | 0.005 | 0.004 | N/A | N/L |
| 38 | 0.000 | 0.000 | N/A | 0.000 | 0.000 | N/A | N/L |
| 39 | 0.006 | 0.002 | N/A | 0.006 | 0.003 | N/A | N/L |
| 40 | 0.000 | 0.000 | N/A | 0.000 | 0.000 | N/A | N/L |

Note: The EUT power level is below 75.0 Watts and therefore has no defined limits

Voltage Source Verification Data (Run time)

| | |
|--------------|--------------|
| Test Voltage | AC 230V/50Hz |
| Test Mode | Mode 1 |

Highest parameter values during test:

| | |
|------------------------|----------------------|
| Voltage (Vrms): 229.95 | Frequency(Hz): 50.00 |
| I Peak (Amps): 1.301 | I RMS (Amps): 0.268 |
| I Fund (Amps): 0.109 | Crest Factor: 4.875 |
| Power (Watts): 23.5 | Power Factor: 0.384 |

| Harm# | Harmonics V-rms | Limit V-rms | % of Limit | Status |
|-------|-----------------|-------------|------------|--------|
| 2 | 0.132 | 0.460 | 28.75 | OK |
| 3 | 0.531 | 2.069 | 25.66 | OK |
| 4 | 0.063 | 0.460 | 13.71 | OK |
| 5 | 0.029 | 0.920 | 3.19 | OK |
| 6 | 0.034 | 0.460 | 7.41 | OK |
| 7 | 0.060 | 0.690 | 8.75 | OK |
| 8 | 0.020 | 0.460 | 4.40 | OK |
| 9 | 0.030 | 0.460 | 6.61 | OK |
| 10 | 0.021 | 0.460 | 4.54 | OK |
| 11 | 0.059 | 0.230 | 25.81 | OK |
| 12 | 0.016 | 0.230 | 6.94 | OK |
| 13 | 0.047 | 0.230 | 20.62 | OK |
| 14 | 0.017 | 0.230 | 7.24 | OK |
| 15 | 0.053 | 0.230 | 22.85 | OK |
| 16 | 0.016 | 0.230 | 6.87 | OK |
| 17 | 0.042 | 0.230 | 18.22 | OK |
| 18 | 0.012 | 0.230 | 5.12 | OK |
| 19 | 0.048 | 0.230 | 21.08 | OK |
| 20 | 0.018 | 0.230 | 7.72 | OK |
| 21 | 0.033 | 0.230 | 14.51 | OK |
| 22 | 0.011 | 0.230 | 4.91 | OK |
| 23 | 0.037 | 0.230 | 16.17 | OK |
| 24 | 0.006 | 0.230 | 2.53 | OK |
| 25 | 0.024 | 0.230 | 10.63 | OK |
| 26 | 0.008 | 0.230 | 3.28 | OK |
| 27 | 0.027 | 0.230 | 11.66 | OK |
| 28 | 0.008 | 0.230 | 3.32 | OK |
| 29 | 0.011 | 0.230 | 4.68 | OK |
| 30 | 0.006 | 0.230 | 2.50 | OK |
| 31 | 0.012 | 0.230 | 5.06 | OK |
| 32 | 0.006 | 0.230 | 2.82 | OK |
| 33 | 0.006 | 0.230 | 2.46 | OK |
| 34 | 0.003 | 0.230 | 1.16 | OK |
| 35 | 0.007 | 0.230 | 3.13 | OK |
| 36 | 0.003 | 0.230 | 1.35 | OK |
| 37 | 0.014 | 0.230 | 5.99 | OK |
| 38 | 0.003 | 0.230 | 1.44 | OK |
| 39 | 0.009 | 0.230 | 3.81 | OK |
| 40 | 0.006 | 0.230 | 2.66 | OK |

5.2 VOLTAGE CHANGES, VOLTAGE FLUCTUATIONS AND FLICKER TEST

5.2.1 LIMITS

| Tests | Limits | Descriptions |
|-------|--------------------------|----------------------------------|
| | EN 61000-3-3 | |
| Pst | ≤ 1.0 , Tp= 10 min. | Short Term Flicker Indicator |
| Plt | ≤ 0.65 , Tp=2 hr. | Long Term Flicker Indicator |
| dc | $\leq 3.3\%$ | Relative Steady-State V-Chang |
| dmax | $\leq 4\%$ | Maximum Relative V-change |
| d (t) | ≤ 500 ms | Relative V-change characteristic |

5.2.2 MEASUREMENT INSTRUMENTS LIST

| Item | Kind of Equipment | Manufacturer | Type No. | Series Model | Calibrated until |
|------|--------------------------------|------------------------|------------------------|--------------|------------------|
| 1 | Harmonics and Flicker Analyzer | California Instruments | PACS-1 | 72344 | Jul. 25, 2021 |
| 2 | 3KVA AC Power source | California Instruments | 3001ix | 56309 | Jul. 25, 2021 |
| 3 | Measurement Software | California | CTS4.0 Version 4.23 | N/A | N/A |

Remark: "N/A" denotes no model no., no serial No. or no calibration specified.

All calibration period of equipment list is one year.

5.2.3 TEST PROCEDURE

- a. Tests was performed according to the Test Conditions/Assessment of Voltage Fluctuations specified in EN 61000-3-3 depend on which standard adopted for compliance measurement.
- b. All types of harmonic current and/or voltage fluctuation in this report are assessed by direct measurement using flicker-meter.

5.2.4 DEVIATION FROM TEST STANDARD

No deviation

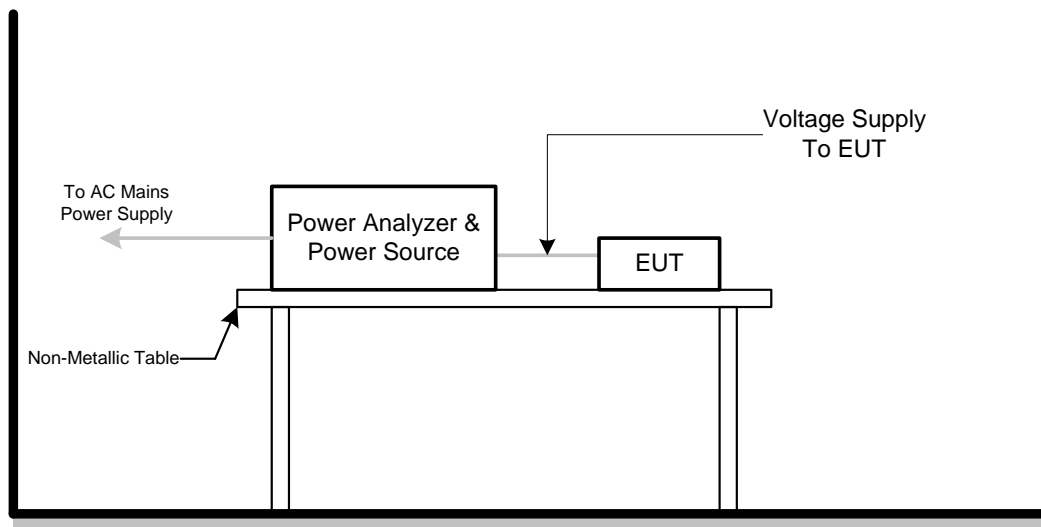
5.2.5 TEST SETUP

5.2.6 TEST RESULTS

| | |
|--------------|--------------|
| Test Voltage | AC 230V/50Hz |
| Test Mode | Mode 1 |

Pst and limit line

European Limits

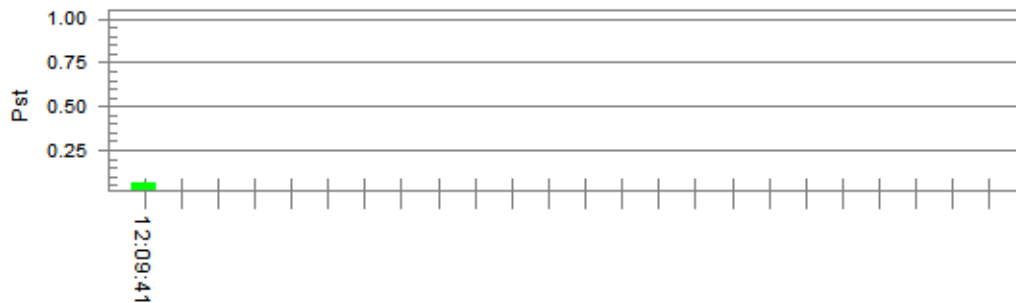

Plt and limit line



Parameter values recorded during the test:

| | | | | |
|---------------------------------|--------|------------------|-------|------|
| Vrms at the end of test (Volt): | 229.91 | Test limit (mS): | 500.0 | Pass |
| T-max (mS): | 0 | Test limit (%): | 3.30 | Pass |
| Highest dc (%): | 0.00 | Test limit (%): | 4.00 | Pass |
| Highest dmax (%): | 0.00 | Test limit: | 1.000 | Pass |
| Highest Pst (10 min. period): | 0.064 | Test limit: | 0.650 | Pass |
| Highest Plt (2 hr. period): | 0.028 | | | |

6. EMC IMMUNITY TEST

6.1 STANDARD COMPLIANCE/SEVERITY LEVEL/CRITERIA

| Tests Standard No. | Test Specification Level / Test Mode | Test Ports | Criteria |
|---|---|--|----------|
| Electrostatic discharge IEC 61000-4-2 (ESD) | ±8kV air discharge ±4kV contact discharge (Direct Mode) | Enclosure | B |
| | ±4kV HCP discharge ±4kV VCP discharge (Indirect Mode) | Enclosure | B |
| Continuous RF electromagnetic field disturbances,swept test IEC 61000-4-3 (RS) | 80 MHz to 1000 MHz 3V/m(unmodulated, r.m.s), 1 kHz, 80%, AM modulated | Enclosure | A |
| Continuous RF electromagnetic field disturbances,spot test IEC 61000-4-3 (RS) | 1800 MHz, 2600MHz, 3500 MHz, 5000MHz(±1 %) 3V/m(unmodulated, r.m.s), 1 kHz, 80%, AM modulated | Enclosure | A |
| Electrical fast transient/burst immunity IEC 61000-4-4 (EFT) | ±0.5kV(peak) 5/50ns Tr/Th 5kHz Repetition Frequency (100kHz Repetition Frequency for xDSL port) | Analogue/digital data ports (NOTE 2) | B |
| | ±0.5kV(peak) 5/50ns Tr/Th 5kHz Repetition Frequency | DC network power ports (NOTE 2) | B |
| | ±1 kV(peak) 5/50ns Tr/Th 5kHz Repetition Frequency | AC mains power ports | B |

| | | | |
|---|--|---|---|
| Surge immunity IEC 61000-4-5 (Surge) | Port Type: unshielded symmetrical | | |
| | Apply: lines to ground | | |
| | Primary protection is Intended ±1 kV 10/700(5/320)Tr/Th µs | Analogue/digital data ports (NOTE 1) & (NOTE 2) | C |
| | Primary protection is not Intended ±1 kV 10/700(5/320) Tr/Th µs | | C |
| | Port type: coaxial or shielded | | |
| | Apply: shield to ground | | |
| ±0.5 kV 1.2/50(8/20) Tr/Th µs | Analogue/digital data ports (NOTE 1) & (NOTE 2) | B | |
| line to reference ground for each individual line: ±0.5 kV(peak) 1.2/50(8/20) Tr/Th µs | DC network power ports (NOTE 2) | B | |
| ±1 kV(peak) 1.2/50(8/20) Tr/Th µs (line to line) ±2 kV(peak) 1.2/50(8/20) Tr/Th µs (line to earth or ground) | AC mains power ports | B | |
| Continuous induced RF disturbances IEC 61000-4-6 (CS) | 0.15 MHz to 10 MHz 3V(unmodulated, r.m.s), 10 MHz to 30 MHz 3V to 1V(unmodulated, r.m.s), 30 MHz to 80 MHz 1V(unmodulated, r.m.s), 1kHz 80%, AM 150Ω source impedance | Analogue/digital data ports (NOTE 2) | A |
| | 0.15 MHz to 10 MHz 3V(unmodulated, r.m.s), 10 MHz to 30 MHz 3V to 1V(unmodulated, r.m.s), 30 MHz to 80 MHz 1V(unmodulated, r.m.s), 1kHz 80%, AM 150Ω source impedance | DC network power ports (NOTE 2) | A |
| | 0.15 MHz to 10 MHz 3V(unmodulated, r.m.s), 10 MHz to 30 MHz 3V to 1V(unmodulated, r.m.s), 30 MHz to 80 MHz 1V(unmodulated, r.m.s), 1kHz 80%, AM 150Ω source impedance | AC mains power ports | A |

| | | | |
|---|--|--|-------------|
| Power frequency magnetic field immunity IEC 61000-4-8 (PFMF) | 50 Hz or 60Hz, 1A/m(r.m.s) | Enclosure | A |
| Voltage dips, short interruptions and voltage variations immunity IEC 61000-4-11 (Dips) | Voltage dips: Residual voltage < 5% 0.5 cycle Residual voltage < 70% 25 cycle(50Hz), 30 cycle (60Hz) Voltage interruptions: Residual voltage < 5% 250 cycle (50Hz), 300 cycle (60Hz) | AC Power Ports | B C C |
| Broadband impulse noise disturbances, repetitive (BIN-R) | 0.15MHz to 0.5 MHz 107dBuV 0.5 MHz to 10 MHz 107dBuV to 36dBuV 10 MHz to 30 MHz 36dBuV to 30 dBuV | Analogue/digital data ports (Applicable only to CPE xDSL ports) | A |
| | 0.70 ms 8.3 ms(for 60Hz) 10 ms(for 50Hz) | Analogue/digital data ports (Apply period based on the AC mains frequency) | A |
| Broadband impulse noise disturbances, isolated (BIN-I) | 0.15MHz to 30 MHz 110dBuV | Analogue/digital data ports (Applicable only to CPE xDSL ports) | B |
| | 0.24 ms 10 ms 300 ms | Analogue/digital data ports (Apply all burst durations) | B |

Note.

- 1) Applicable only to ports which, according to the manufacturer's specification, may connect directly to outdoor cables.
- 2) Applicable only to ports which, according to the manufacturer's specification, support cable lengths greater than 3 m.

6.2 GENERAL PERFORMANCE CRITERIA

According to **EN55035** standard, the general performance criteria as following:

| | |
|--------------------|---|
| Criterion A | <p>The equipment shall continue to operate as intended without operator intervention. No degradation of performance, loss of function or change of operating state is allowed below a performance level specified by the manufacturer when the equipment is used as intended. The performance level may be replaced by a permissible loss of performance. If the minimum performance level or the permissible performance loss is not specified by the manufacturer, then either of these may be derived from the product description and documentation, and by what the user may reasonably expect from the equipment if used as intended.</p> |
| Criterion B | <p>During the application of the disturbance, degradation of performance is allowed. However, nonintended change of actual operating state or stored data is allowed to persist after the test.</p> <p>After the test, the equipment shall continue to operate as intended without operator intervention; no degradation of performance or loss of function is allowed, below a performance level specified by the manufacturer, when the equipment is used as intended. The performance level may be replaced by a permissible loss of performance. If the minimum performance level (or the permissible performance loss), or recovery time, is not specified by the manufacturer, then either of these may be derived from the product description and documentation, and by what the user may reasonably expect from the equipment if used as intended.</p> |
| Criterion C | <p>Loss of function is allowed, provided the function is self-recoverable, or can be restored by the operation of the controls by the user in accordance with the manufacturer's instructions. Areboot or re-start operation is allowed.</p> <p>Information stored in non-volatile memory, or protected by a battery backup, shall not be lost.</p> |

6.3 ANNEX D (NORMATIVE) - DISPLAY AND DISPLAY OUTPUT FUNCTION

6.3.1 PERFORMANCE CRITERIA

Performance criterion A

for continuous radiated and conducted disturbances tests:

Apply criterion A as defined in GENERAL PERFORMANCE CRITERIA. Additionally, an increase in any degradation greater than just perceptible by observation of the image shall not occur as a consequence of the application of the test. Examples of such degradations are:

- superimposed patterning;
- positional disturbances due to synchronisation errors;
- geometric distortion;
- change of contrast or brightness;
- picture artefacts;
- freezing or disturbance of motion;
- image loss;
- video data or decoding errors.

Performance criterion A

for the power frequency magnetic field tests:

Alternative 1: A continuous magnetic field of 1 A/m:

The jitter (in mm) shall not exceed the value
$$\frac{(\text{character height in mm} + 0,3) \times 2,5}{33,3}$$

Performance criterion B:

Apply criterion B as defined in GENERAL PERFORMANCE CRITERIA.

Performance criterion C:

Apply criterion C as defined in GENERAL PERFORMANCE CRITERIA.

6.4 ANNEX G (NORMATIVE) - AUDIO OUTPUT FUNCTION

6.4.1 PERFORMANCE CRITERIA

Performance criterion A:

For devices that support telephony functions the limits of Table G.3 shall apply.

With respect to Table G.3:

- the interference ratio (electrical or acoustic) shall meet the limits in column 3; or,
- the acoustic level of the demodulated audio shall be less than the limits in column 4; or,
- the digitally coded level of demodulated audio shall be less than limits in column 5; or,
- the analogue level of the demodulated audio shall be less than the limits in column 6.

Table G.3 – Performance criterion A – Limits for devices supporting telephony

| Type of immunity test | Frequency range MHz | Acoustic or electrical interference ratio | Equivalent direct measurement | | |
|-----------------------|---------------------|---|-------------------------------|--------------|--------------|
| | | | dB (SPL) | Digital dBm0 | Analogue dBm |
| Conducted | 0,15 to 30 | -20 dB | 55 | -50 | -50 |
| | 30 to 80 | -10 dB | 65 | -40 | -40 |
| Radiated | 80 to 1000 | 0 dB | 75 | -30 | -30 |

For terminals connected to digital wired network ports (such as Ethernet, ISDN), measurements of the demodulated 1 kHz may be performed on a remote AE, ideally of the same design.

For all other devices:

The measured acoustic interference ratio and/or the measured electrical interference ratio during the test shall be -20 dB or better.

Performance criterion B:

Use the general performance criterion B. See GENERAL PERFORMANCE CRITERIA.

Performance criterion C:

Use the general performance criterion C. See GENERAL PERFORMANCE CRITERIA.

6.5 ELECTROSTATIC DISCHARGE IMMUNITY TEST (ESD)

6.5.1 TEST SPECIFICATION

| | |
|----------------------|---|
| Basic Standard | IEC 61000-4-2 |
| Discharge Impedance | 330 ohm / 150 pF |
| Required Performance | B |
| Discharge Voltage | Air Discharge: $\pm 2\text{kV}$, $\pm 4\text{kV}$, $\pm 8\text{kV}$ Contact Discharge: $\pm 2\text{kV}$, $\pm 4\text{kV}$ |
| Polarity | Positive & Negative |
| Number of Discharge | 20 times at each test point |
| Discharge Mode | Single Discharge |
| Discharge Period | 1 second |

6.5.2 MEASUREMENT INSTRUMENTS

| Item | Kind of Equipment | Manufacturer | Type No. | Series Model | Calibrated until |
|------|-------------------|--------------|----------|--------------|------------------|
| 1 | ESD Generator | TESEQ AG | NSG 437 | 450 | Dec. 03, 2021 |

Remark: "NA" denotes no model no., no serial No. or no calibration specified.

All calibration period of equipment list is one year.

6.5.3 TEST PROCEDURE

The test generator necessary to perform direct and indirect application of discharges to the EUT in the following manner:

- a. The test shall be performed with single discharges. On each pre-selected point at least 10 single discharges (in the most sensitive polarity) shall be applied.

NOTE 1 The minimum number of discharges applied is depending on the EUT; for products with synchronized circuits the number of discharges should be larger.

For the time interval between successive single discharges an initial value of 1 s is recommended. Longer intervals may be necessary to determine whether a system failure has occurred.

NOTE 2 The points to which the discharges should be applied may be selected by means of an exploration carried out at a repetition rate of 20 discharges per second, or more.

Vertical Coupling Plane (VCP):

The coupling plane, of dimensions 0.5m x 0.5m, is placed parallel to, and positioned at a distance 0.1m from, the EUT, with the Discharge Electrode touching the coupling plane.

The four faces of the EUT will be performed with electrostatic discharge.

Horizontal Coupling Plane (HCP):

The coupling plane is placed under to the EUT. The generator shall be positioned vertically at a distance of 0.1m from the EUT, with the Discharge Electrode touching the coupling plane.

The four faces of the EUT will be performed with electrostatic discharge.

- b. For TABLE-TOP equipment:

The configuration consisted of a wooden table 0.8 meters high standing on the Ground Reference Plane. The GRP consisted of a sheet of aluminum at least 0.25mm thick, and 2.5 meters square connected to the protective grounding system. A Horizontal Coupling Plane (1.6m x 0.8m) was placed on the table and attached to the GRP by means of a cable with 940k total impedance. The equipment under test was installed in a representative system as described in IEC 61000-4-2, and its cables were placed on the HCP and isolated by an insulating support of 0.5mm thickness. A distance of 1-meter minimum was provided between the EUT and the walls of the laboratory and any other metallic structure.

6.5.4 DEVIATION FROM TEST STANDARD

No deviation

6.5.5 TEST SETUP

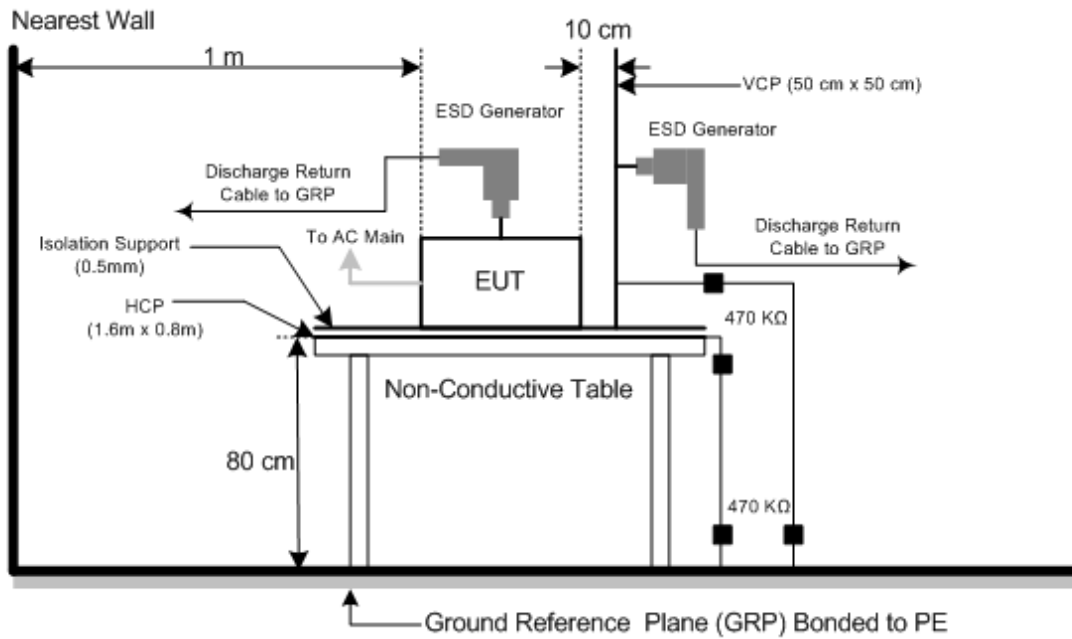

6.5.6 TEST RESULTS

| | |
|--------------|---------------------|
| Test Voltage | AC 230V/50Hz |
| Test Mode | Mode 1-6, Mode 9-10 |

| Mode | Air Discharge | | | | | | | | Contact Discharge | | | | | |
|------------|---------------|---|-----|---|-----|---|------|---|-------------------|---|-----|---|------|---|
| | 2kV | | 4kV | | 8kV | | - kV | | 2kV | | 4kV | | - kV | |
| Test Level | P | N | P | N | P | N | P | N | P | N | P | N | P | N |
| Location | P | N | P | N | P | N | P | N | P | N | P | N | P | N |
| 1 | A | A | A | A | B | B | - | - | A | A | B | B | - | - |
| 2 | A | A | A | A | A | A | - | - | - | - | - | - | - | - |
| 3 | A | A | A | A | B | B | - | - | - | - | - | - | - | - |
| 4 | A | A | A | A | A | A | - | - | - | - | - | - | - | - |
| 5 | A | A | A | A | B | B | - | - | - | - | - | - | - | - |
| Criteria | B | | | | | | - | | B | | | | - | |
| Result | B | | | | | | - | | B | | | | - | |

| Mode | HCP Contact Discharge | | | | | | VCP Contact Discharge | | | | | |
|------------|-----------------------|---|-----|---|------|---|-----------------------|---|-----|---|------|---|
| | 2kV | | 4kV | | - kV | | 2kV | | 4kV | | - kV | |
| Test Level | P | N | P | N | P | N | P | N | P | N | P | N |
| Location | P | N | P | N | P | N | P | N | P | N | P | N |
| Left side | A | A | A | A | - | - | A | A | A | A | - | - |
| Right side | A | A | A | A | - | - | A | A | A | A | - | - |
| Front side | A | A | A | A | - | - | A | A | A | A | - | - |
| Rear side | A | A | A | A | - | - | A | A | A | A | - | - |
| Criteria | B | | | | - | | B | | | | - | |
| Result | A | | | | - | | A | | | | - | |

Note:

- 1) P/N denotes the Positive/Negative polarity of the output voltage.
- 2) N/A - denotes test is not applicable in this test report

PHOTO(S) SHOWN THE LOCATION(S) OF ESD EVALUATED

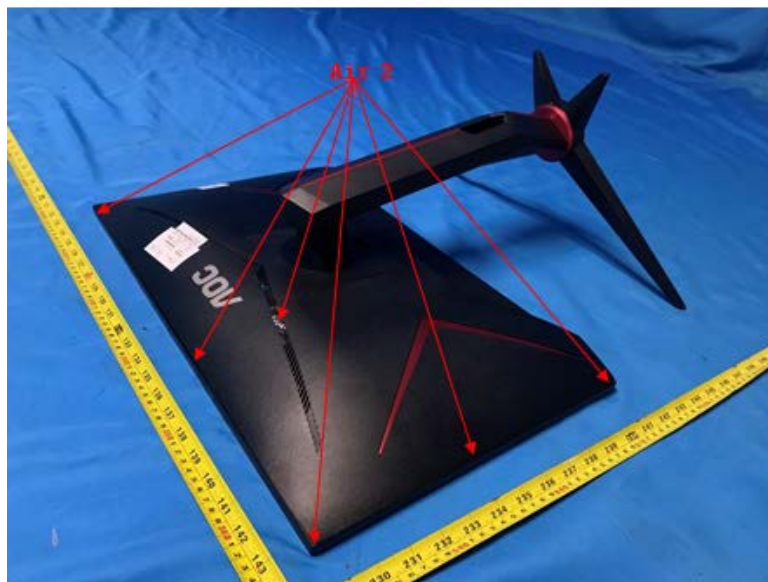
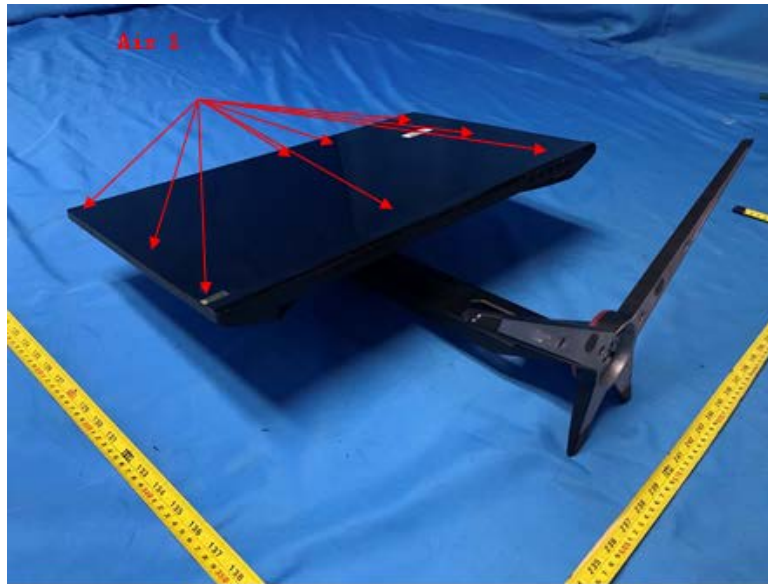

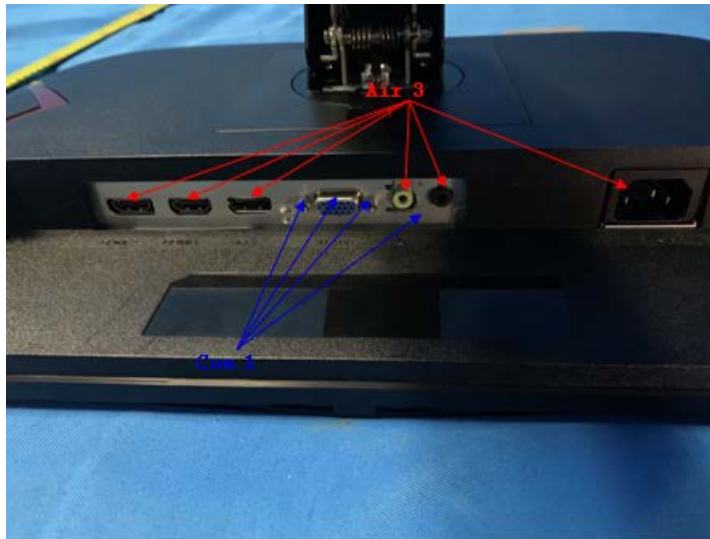

6.6 RADIATED, RADIO-FREQUENCY, ELECTROMAGNETIC FIELD IMMUNITY TEST (RS)

6.6.1 TEST SPECIFICATION

| | |
|----------------------|---|
| Basic Standard | IEC 61000-4-3 |
| Required Performance | A |
| Frequency Range | 80 MHz - 1000 MHz, 1800 MHz, 2600 MHz, 3500 MHz, 5000MHz |
| Field Strength | 3 V/m(unmodulated, r.m.s) |
| Modulation | 1 kHz Sine Wave, 80%, AM Modulation |
| Frequency Step | 1% of fundamental |
| Polarity of Antenna | Horizontal and Vertical |
| Test Distance | 3 m |
| Antenna Height | 1.55 m |
| Dwell Time | 3 seconds |

6.6.2 MEASUREMENT INSTRUMENTS

| Item | Kind of Equipment | Manufacturer | Type No. | Series Model | Calibrated until |
|------|-----------------------------|--------------|--------------------|--------------|------------------|
| 1 | Antenna | ETS | 3142C | 47662 | Jun. 03, 2021 |
| 2 | Amplifier | AR | 50S1G4A | 326720 | Feb. 28, 2022 |
| 3 | MXG Analog Signal Generator | Agilent | N5181A | MY49060710 | Jul. 25, 2021 |
| 4 | Power amplifier | MILMEGA | AS1860-50 | 1064834 | Feb. 28, 2022 |
| 5 | Microwave Log.-Per. Antenna | TESEQ | STLP 9149 | 9149-277 | Apr. 13, 2022 |
| 6 | Power amplifier | MILMEGA | 80RF1000-250 | 1064833 | Feb. 28, 2022 |
| 7 | Measurement Software | TOYO | IM5/RS Ver 3.8.050 | N/A | N/A |
| 8 | Conditioning Amplifier | B&K | _2690_0F2_ | 2723746 | Jun. 18, 2021 |
| 9 | Free-field 1/2` Microphone | B&K | 4190-L-001 | 2878077 | Jun. 17, 2021 |
| 10 | UPV Audio Analyzer | R&S | UPV | 104259 | Feb. 27, 2022 |

Remark: "N/A" denotes no model no., no serial No. or no calibration specified.

"**" calibration period of equipment list is three year.

Except * item, all calibration period of equipment list is one year.

6.6.3 TEST PROCEDURE

The EUT and support equipment are in a fully-anechoic chamber.

The testing distance from antenna to the EUT was 3 meters.

For TABLE-TOP equipment:

The EUT installed in a representative system as described in IEC 61000-4-3 was placed on a non-conductive table 0.8 meters in height. The system under test was connected to the power and signal wire according to relevant installation instructions.

The other condition as following manner:

- The field strength level was 3 V/m(unmodulated, r.m.s).
- The frequency range is swept from 80 MHz to 1000 MHz, with the signal 80%amplitude modulated with a 1 kHz sine wave. The rate of sweep did not exceed 1.5×10^{-3} decade/s. Where the frequency range is swept incrementally, the step size was 1% of fundamental.
- The dwell time at each frequency shall be not less than the time necessary for the EUT to be able to respond.
- The test was performed with the EUT exposed to both vertically and horizontally polarized fields on each of the four sides.

For Display and display output functions:

- a. The display quality evaluated by direct observation.
- b. For display output function evaluation, a suitable display device shall be connected. This device shall meet the immunity requirements for displays specified in this document. The screen size shall be typical for the display output. the diagonal screen size shall be at least 0,50 m.
- c. The display shall be observed under normal viewing conditions including viewing distance using a reduced ambient light level preferably in the range 15 lx to 20 lx. The viewing distance or settings of the video camera monitoring system shall be sufficient to provide visibility of the whole display. In the case of direct observation the selected viewing distance shall be recorded in the test report.

For Acoustic measurements:

- a. Apply an appropriate input signal to the EUT so that a sine wave (tone) at the frequency that will be used to modulate the applied disturbance (typically 1 kHz) is generated from the port under test at a level equal to the acoustic reference level.
- b. Record the resulting dB (SPL) level (or other appropriate dB unit) as the value of L0. (BTL lab uses the software to take L0 as the reference value and make it return to zero.)
- c. Change the input to the EUT so that the port under test is silent, or represents silence. This change shall not alter the terminating impedance at the EUT's input.
- d. Apply the RF disturbance to the applicable port of the EUT and record the resulting demodulated audio level in dB (SPL) (or other dB unit used in step d)) as the value of L1.
- e. Ensure that non-linear processing does not impact the measurements.
- f. Calculate the acoustic interference ratio using the following formula:
Acoustic interference ratio = L1 – L0.
(For step e-g, BTL lab proceeds the test with software and calculate Acoustic interference ratio = L1 – L0).

6.6.4 DEVIATION FROM TEST STANDARD

No deviation

6.6.5 TEST SETUP

a) For Continuous induced RF disturbances

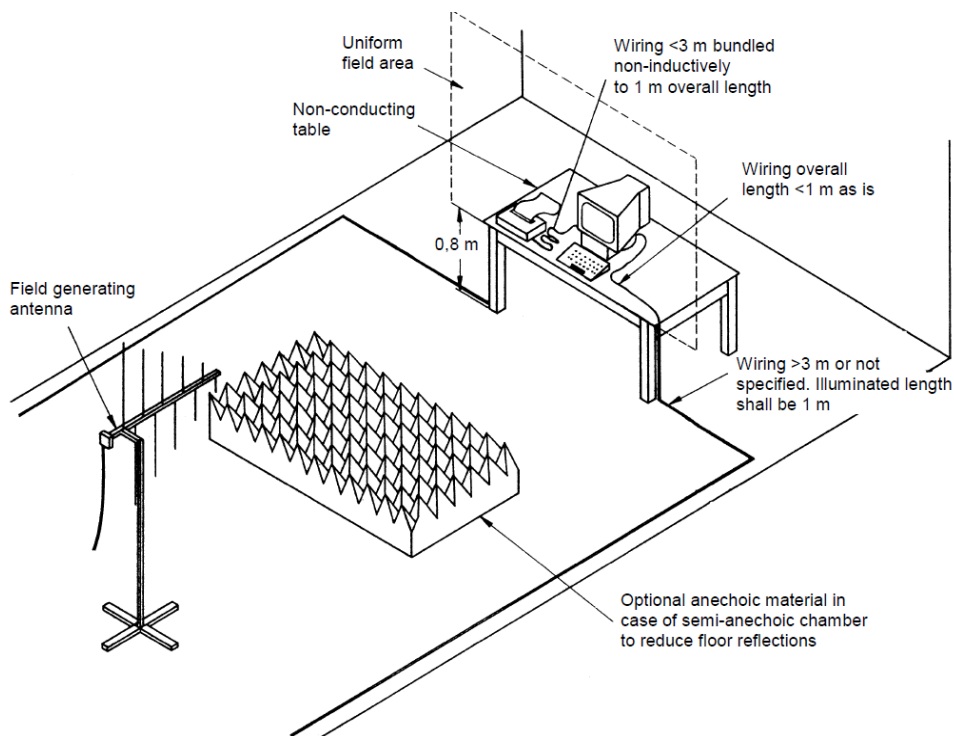

For Audio output function

(1) Audio output port

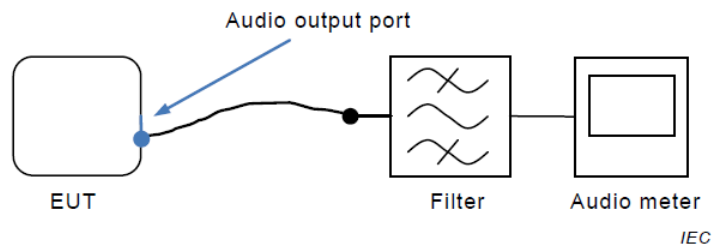

The filter is the audio filter specified in G.6.1 and is typically incorporated into the audio meter. Additional filtering might be necessary to ensure that the RF disturbance signal does not interfere with the measurement.

(2) Loudspeaker

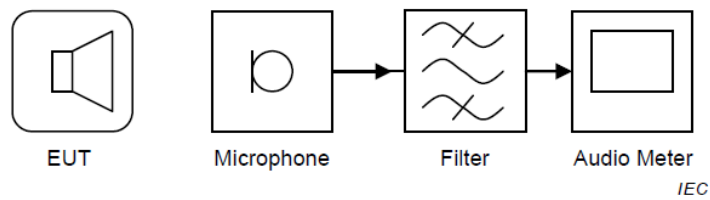

The filter is the audio filter specified in G.6.1 and is typically incorporated into the audio meter. Additional filtering might be necessary to ensure that the RF disturbance signal does not interfere with the measurement.

6.6.6 TEST RESULTS

| | |
|--------------|---------------------|
| Test Voltage | AC 230V/50Hz |
| Test Mode | Mode 1-6, Mode 9-10 |

| Frequency Range (MHz) | RF Field Position | R.F. Field Strength | Modulation | Azimuth | Criterion | Result |
|------------------------------------|-------------------|---------------------|-----------------------------|---------|-----------|--------|
| 80 - 1000 | H / V | 3V/m | AM Modulated 1000Hz, 80% | 0 | A | A |
| | | | | 90 | | |
| | | | | 180 | | |
| | | | | 270 | | |
| 1800, 2600, 3500, 5000 (±1%) | H / V | 3V/m | AM Modulated 1000Hz, 80% | 0 | A | A |
| | | | | 90 | | |
| | | | | 180 | | |
| | | | | 270 | | |

For Audio output function

(1) Audio output port:

| | |
|--------------|-----------------------|
| Test Voltage | AC 230V/50Hz |
| Test Mode | Mode 1_Vertical_Front |

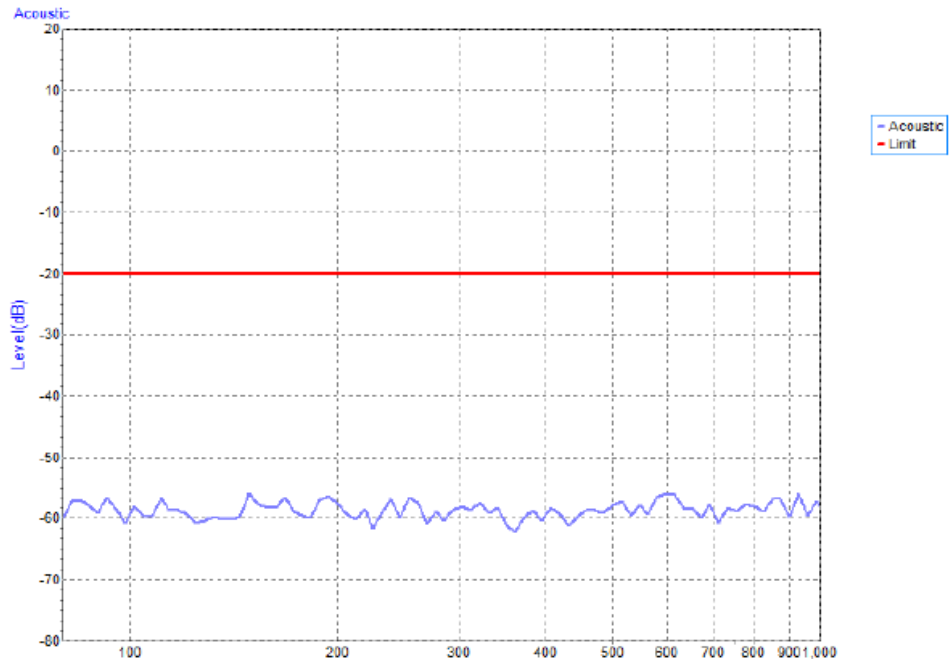

| | |
|--------------|-------------------------|
| Test Voltage | AC 230V/50Hz |
| Test Mode | Mode 1_Horizontal_Front |

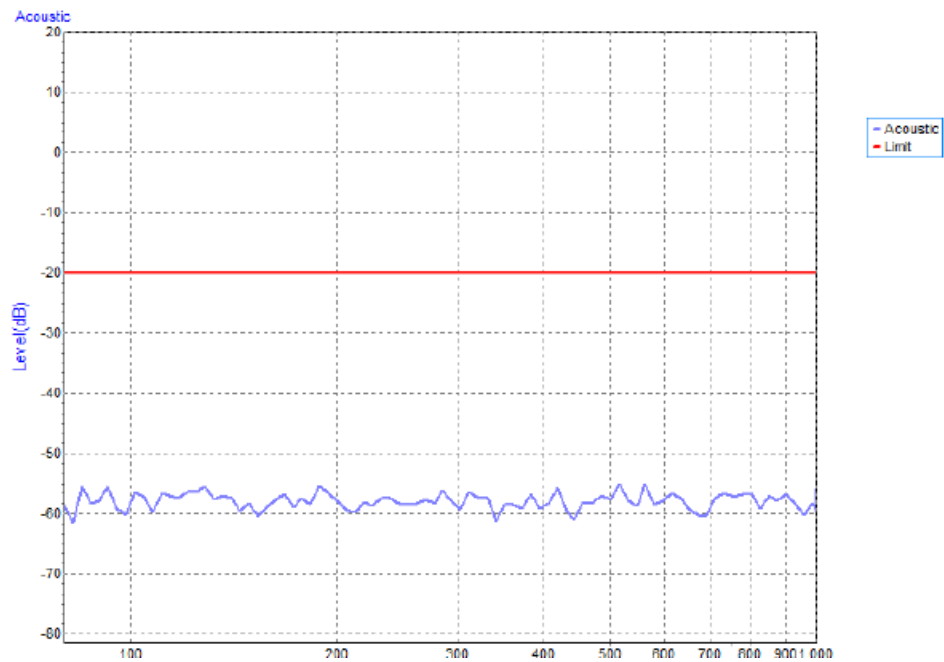

(2) Loudspeaker:

| | |
|--------------|-----------------------|
| Test Voltage | AC 230V/50Hz |
| Test Mode | Mode 1_Vertical_Front |

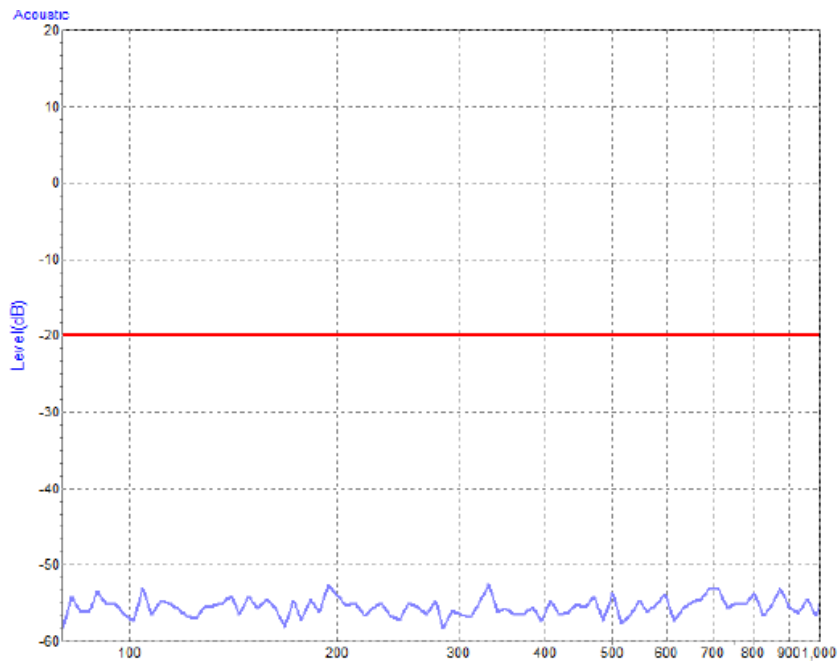

| | |
|--------------|-------------------------|
| Test Voltage | AC 230V/50Hz |
| Test Mode | Mode 1_Horizontal_Front |

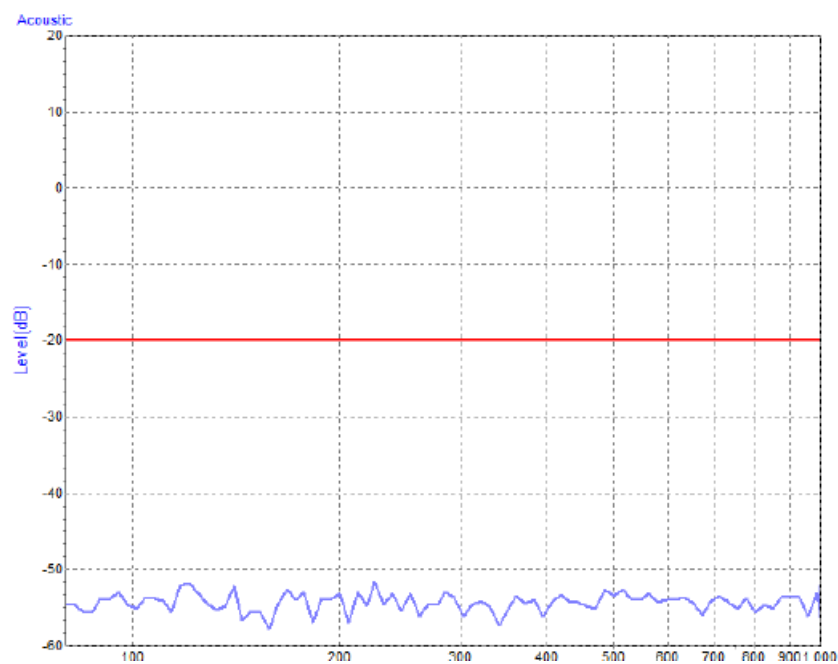

6.7 ELECTRICAL FAST TRANSIENT/BURST IMMUNITY TEST (EFT/BURST)

6.7.1 TEST SPECIFICATION

| | |
|----------------------|-------------------------------|
| Basic Standard | IEC 61000-4-4 |
| Required Performance | B |
| Test Voltage | AC Power Ports:±1 kV |
| Polarity | Positive & Negative |
| Impulse Frequency | 5 kHz: except for xDSL ports. |
| Impulse Wave shape | 5/50 ns |
| Burst Duration | 15 ms |
| Burst Period | 300 ms |
| Test Duration | 1 min. |

6.7.2 MEASUREMENT INSTRUMENTS

| Item | Kind of Equipment | Manufacturer | Type No. | Series Model | Calibrated until |
|------|--------------------------------|--------------|------------|--------------|------------------|
| 1 | Fast Transient Burst Simulator | Prima | EFT61004TA | PR190741004 | Jul. 25, 2021 |

Remark: "N/A" denotes no model no., no serial No. or no calibration specified.

All calibration period of equipment list is one year.

6.7.3 TEST PROCEDURE

For TABLE-TOP equipment:

The configuration consisted of a wooden table (0.8m high) standing on the Ground Reference Plane and should be located 0.1 m+/- 0.01m above the Ground Reference Plane. The GRP consisted of a sheet of aluminum (at least 0.25mm thick and 2.5m square) connected to the protective grounding system. A minimum distance of 0.5m was provided between the EUT and the walls of the laboratory or any other metallic structure.

The other condition as following manner:

- a. Both positive and negative polarity discharges were applied.
- b. The duration time of each test sequential was 1 minute.

6.7.4 DEVIATION FROM TEST STANDARD

No deviation

6.7.5 TEST SETUP

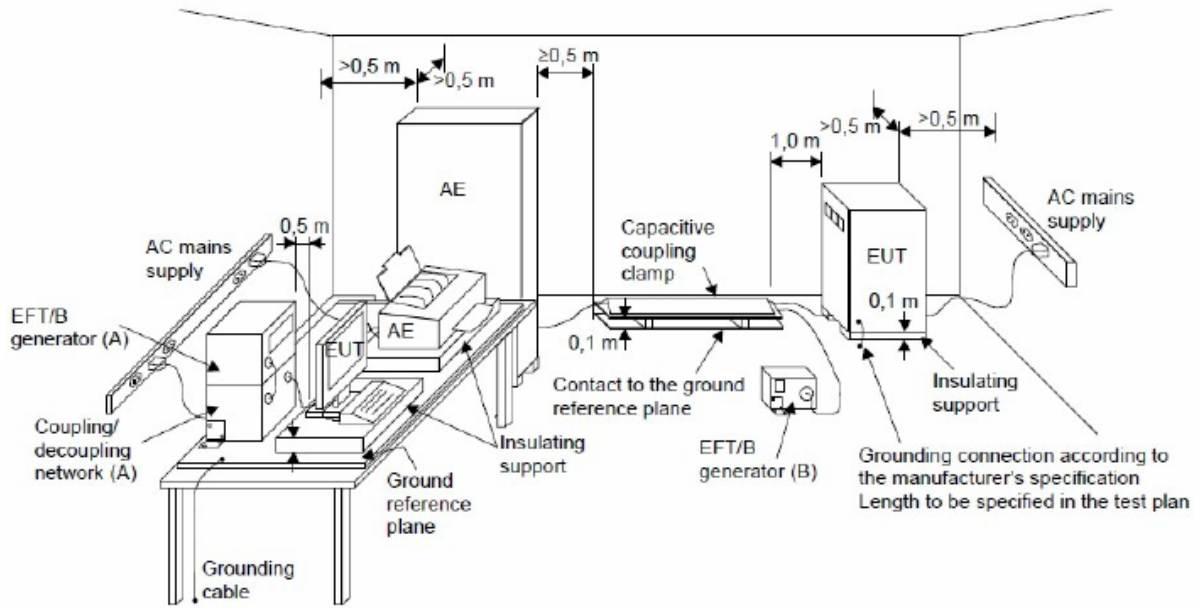

6.7.6 TEST RESULTS

| | |
|--------------|---------------------|
| Test Voltage | AC 230V/50Hz |
| Test Mode | Mode 1-6, Mode 9-10 |

| EUT Ports Tested | | Polarity | Repetition Frequency | Test Level | Criterion | Result |
|------------------|-------------|----------|----------------------|------------|-----------|--------|
| | | | | 1kV | | |
| AC Power Port | Line (L) | + | 5 kHz | A | B | A |
| | | - | 5 kHz | A | | |
| | Neutral (N) | + | 5 kHz | A | B | A |
| | | - | 5 kHz | A | | |
| | Ground (PE) | + | 5 kHz | A | B | A |
| | | - | 5 kHz | A | | |
| | L+N | + | 5 kHz | A | B | A |
| | | - | 5 kHz | A | | |
| | L+PE | + | 5 kHz | A | B | A |
| | | - | 5 kHz | A | | |
| | N+PE | + | 5 kHz | A | B | A |
| | | - | 5 kHz | A | | |
| | L+N+PE | + | 5 kHz | A | B | A |
| | | - | 5 kHz | A | | |

6.8 SURGE IMMUNITY TEST

6.8.1 TEST SPECIFICATION

| | |
|---|---|
| Basic Standard | IEC 61000-4-5 |
| Required Performance | B |
| Wave-Shape | 1.2/50(8/20) Tr/Th μ s combination wave |
| Test Voltage | AC Power Port: ± 0.5 kV, ± 1 kV, ± 2 kV |
| Generator Source Impedance | 2 Ω of the low-voltage power supply network. 12 Ω (10 Ω +2 Ω) of the low-voltage power supply network and ground. |
| Phase Angle, Polarity and Number of Tests | Five positive pulses line-to-neutral at 90° phase Five negative pulses line-to-neutral at 270° phase Five positive pulses line-to-earth at 90° phase Five negative pulses line-to-earth at 270° phase Five negative pulses neutral-to-earth at 90° phase Five positive pulses neutral-to-earth at 270° phase |
| Pulse Repetition Rate | 1 time / min. |

6.8.2 MEASUREMENT INSTRUMENTS

| Item | Kind of Equipment | Manufacturer | Type No. | Series Model | Calibrated until |
|------|---------------------------|--------------|------------|--------------|------------------|
| 1 | Lightning Surge Generator | Prima | SUG61005TB | PR190854067 | Jul. 25, 2021 |

Remark: "N/A" denotes no model no., no serial No. or no calibration specified.

All calibration period of equipment list is one year.

6.8.3 TEST PROCEDURE

a. For EUT power supply:

The surge is to be applied to the EUT power supply terminals via the capacitive coupling network. Decoupling networks are required in order to avoid possible adverse effects on equipment not under test that may be powered by the same lines, and to provide sufficient decoupling impedance to the surge wave. The power cord between the EUT and the coupling/decoupling networks shall be 2meters in length (or shorter).

b. For test applied to unshielded unsymmetrically operated interconnection lines of EUT :

The surge is applied to the lines via the capacitive coupling. The coupling /decoupling networks shall not influence the specified functional conditions of the EUT. The interconnection line between the EUT and the coupling/decoupling networks shall be 2 meters in length (or shorter).

c. For test applied to unshielded symmetrically operated interconnection /telecommunication lines of EUT :

The surge is applied to the lines via gas arrestors coupling. Test levels below the ignition point of the coupling arrestor cannot be specified. The interconnection line between the EUT and the coupling/decoupling networks shall be 2 meters in length (or shorter).

6.8.4 DEVIATION FROM TEST STANDARD

No deviation

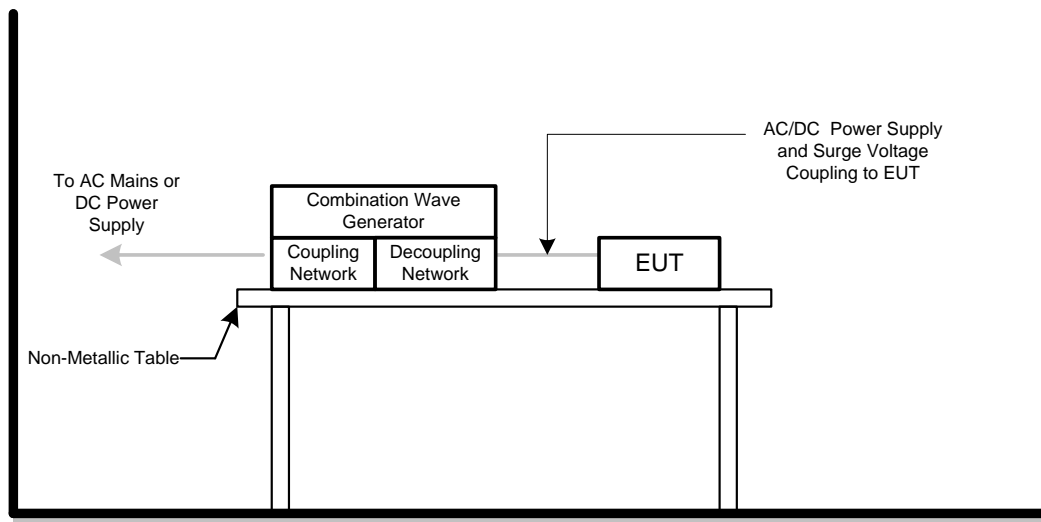
6.8.5 TEST SETUP

6.8.6 TEST RESULTS

| | |
|--------------|---------------------|
| Test Voltage | AC 230V/50Hz |
| Test Mode | Mode 1-6, Mode 9-10 |

| Wave Form EUT Ports Tested | | 1.2/50(8/20)Tr/Thµs | | | | | | Criterion | Result |
|-------------------------------|-------|---------------------|-------|---------|-----|-------|-------|-----------|--------|
| | | Polarity | Phase | Voltage | | | | | |
| | | | | 0.5kV | 1kV | -- kV | -- kV | | |
| AC | L – N | + | 90° | A | A | - | - | B | A |
| | | - | 270° | A | A | - | - | | |

| Wave Form EUT Ports Tested | | 1.2/50(8/20)Tr/Thµs | | | | | | Criterion | Result |
|-------------------------------|--------|---------------------|-------|---------|-----|-----|-------|-----------|--------|
| | | Polarity | Phase | Voltage | | | | | |
| | | | | 0.5kV | 1kV | 2kV | -- kV | | |
| AC | L – PE | + | 90° | A | A | A | - | B | A |
| | | - | 270° | A | A | A | - | | |
| | N – PE | - | 90° | A | A | A | - | B | A |
| | | + | 270° | A | A | A | - | | |

6.9 IMMUNITY TO CONDUCTED DISTURBANCES, INDUCED BY RADIO-FREQUENCY FIELDS TEST (CS)

6.9.1 TEST SPECIFICATION

| | |
|--------------------------------|---|
| Basic Standard | IEC 61000-4-6 |
| Required Performance | A |
| Frequency Range&Field Strength | 0.15 MHz - 10 MHz: 3V (unmodulated, r.m.s.) 10 MHz - 30 MHz: 3V to 1V (unmodulated, r.m.s.) 30 MHz - 80 MHz: 1V (unmodulated, r.m.s.) |
| Modulation | 1 kHz Sine Wave, 80%, AM Modulation |
| Frequency Step | 1% of fundamental |
| Dwell Time | 3 seconds |

6.9.2 MEASUREMENT INSTRUMENTS

| Item | Kind of Equipment | Manufacturer | Type No. | Series Model | Calibrated until |
|------|---|--------------|------------------------|--------------|------------------|
| 1 | Power CDN | FCC | FCC-801-M2/M3 -16A | 100270 | Feb. 27, 2022 |
| 2 | TEST SYSTEM FOR CONDUCTED AND RADIATED IMMUNITY | TESEQ | NSG 4070B | 37513 | Jul. 25, 2021 |
| 3 | Measurement Software | Farad | EZ-CS(V2.0.1.2) | N/A | N/A |
| 4 | Conditioning Amplifier | B&K | <u>2690</u> <u>0F2</u> | 2723746 | Jun. 18, 2021 |
| 5 | Free-field 1/2` Microphone | B&K | 4190-L-001 | 2878077 | Jun. 17, 2021 |
| 6 | UPV Audio Analyzer | R&S | UPV | 104259 | Feb. 27, 2022 |

Remark: "N/A" denotes no model no., no serial No. or no calibration specified.

All calibration period of equipment list is one year.

6.9.3 TEST PROCEDURE

The equipment to be tested is placed on an insulating support of 0.1m height above a reference ground plane. All cables exiting the EUT shall be supported at a height of at least 30 mm above the reference ground plane. All relevant cables shall be provided with the appropriate coupling and decoupling devices at a distance between 0.1 meters and 0.3 meters from the projected geometry of the EUT on the ground reference plane.

The other condition as following manner:

- The field strength level was 3 V (unmodulated, r.m.s.)
- The frequency range is swept from 150 kHz to 80 MHz, with the signal 80%amplitude modulated with a 1 kHz sine wave. The rate of sweep did not exceed 1.5×10^{-3} decade/s. Where the frequency range is swept incrementally, the step size was 1% of fundamental.
- The dwell time at each frequency shall be not less than the time necessary for the EUT to be able to respond.

For Display and display output functions:

- The display quality evaluated by direct observation.
- For display output function evaluation, a suitable display device shall be connected. This device shall meet the immunity requirements for displays specified in this document. The screen size shall be typical for the display output.the diagonal screen size shall be at least 0,50 m.
- The display shall be observed under normal viewing conditions including viewing distance using a reduced ambient light level preferably in the range 15 lx to 20 lx. The viewing distance or settings of the video camera monitoring system shall be sufficient to provide visibility of the whole display. In the case of direct observation the selected viewing distance shall be recorded in the test report.

For Acoustic measurements:

- a. Apply an appropriate input signal to the EUT so that a sine wave (tone) at the frequency that will be used to modulate the applied disturbance (typically 1 kHz) is generated from the port under test at a level equal to the acoustic reference level.
- b. Record the resulting dB (SPL) level (or other appropriate dB unit) as the value of L_0 . (BTL lab uses the software to take L_0 as the reference value and make it return to zero.)
- c. Change the input to the EUT so that the port under test is silent, or represents silence. This change shall not alter the terminating impedance at the EUT's input.
- d. Apply the RF disturbance to the applicable port of the EUT and record the resulting demodulated audio level in dB (SPL) (or other dB unit used in step d)) as the value of L_1 .
- e. Ensure that non-linear processing does not impact the measurements.
- f. Calculate the acoustic interference ratio using the following formula:
 Acoustic interference ratio = $L_1 - L_0$.
 (For step e-g, BTL lab proceeds the test with software and calculate Acoustic interference ratio = $L_1 - L_0$).

6.9.4 DEVIATION FROM TEST STANDARD

No deviation

6.9.5 TEST SETUP

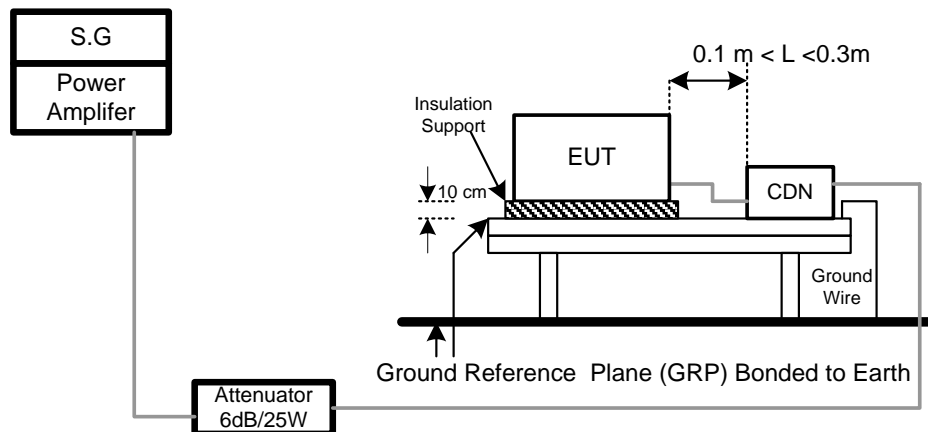

For Audio output function

(1) Audio output port

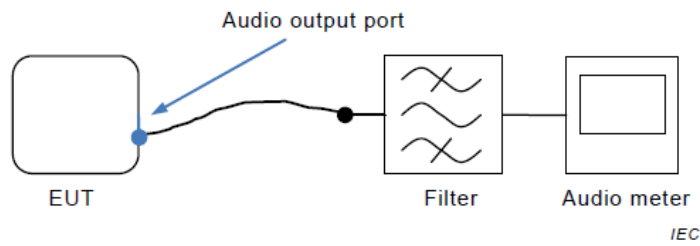

The filter is the audio filter specified in G.6.1 and is typically incorporated into the audio meter. Additional filtering might be necessary to ensure that the RF disturbance signal does not interfere with the measurement.

(2) Loudspeaker

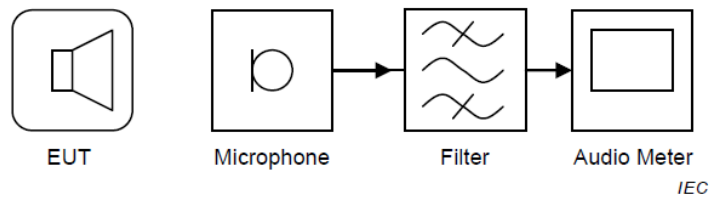

The filter is the audio filter specified in G.6.1 and is typically incorporated into the audio meter. Additional filtering might be necessary to ensure that the RF disturbance signal does not interfere with the measurement.

6.9.6 TEST RESULTS

| | |
|--------------|---------------------|
| Test Voltage | AC 230V/50Hz |
| Test Mode | Mode 1-6, Mode 9-10 |

| Test Ports (Mode) | Freq.Range (MHz) | Field Strength | Modulation | Criteria | Results |
|----------------------|------------------|----------------|-----------------------------|----------|---------|
| AC mains power ports | 0.15 - 10 | 3V | AM Modulated 1000Hz, 80% | A | A |
| | 10 - 30 | 3V to 1V | | | |
| | 30 - 80 | 1V | | | |

For Audio output function

(1) Audio output port:

| | |
|--------------|---------------|
| Test Voltage | AC 230V/50Hz |
| Test Mode | Mode 1_CDN M3 |

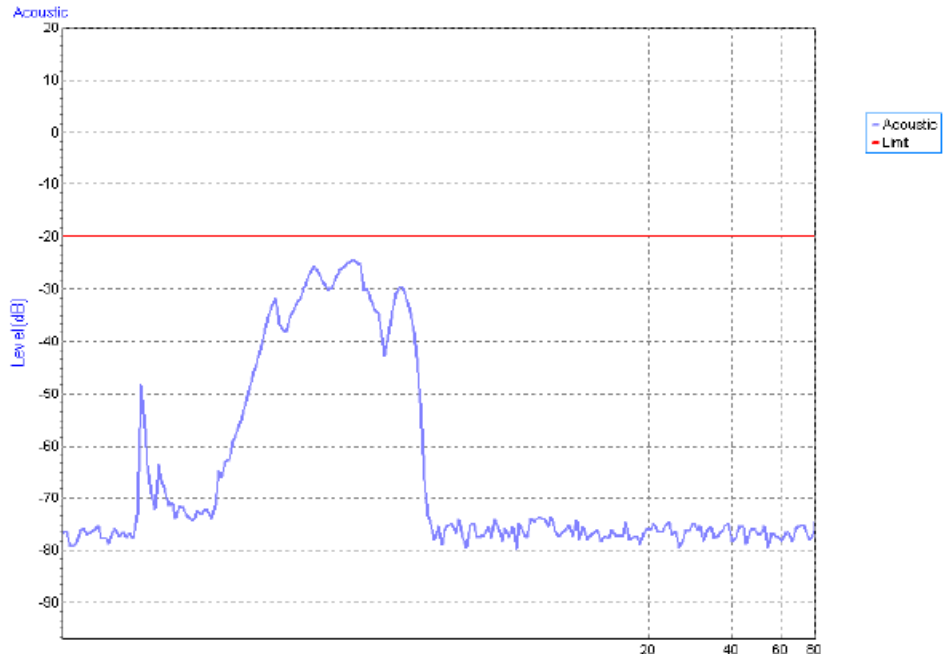

(2) Loudspeaker:

| | |
|--------------|---------------|
| Test Voltage | AC 230V/50Hz |
| Test Mode | Mode 1_CDN M3 |

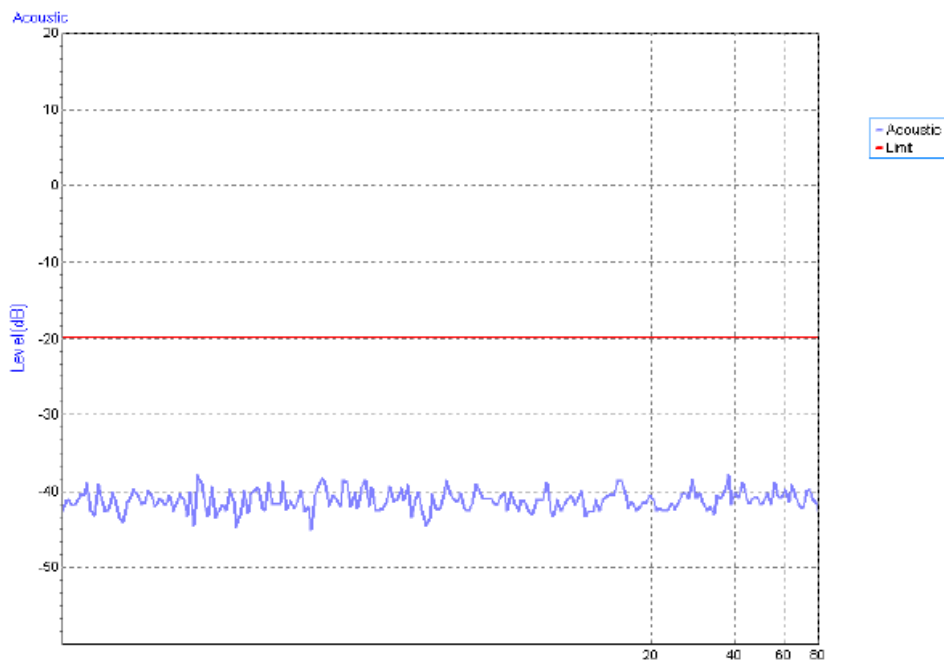

6.10 POWER FREQUENCY MAGNETIC FIELD IMMUNITY TEST (PFMF)

6.10.1 TEST SPECIFICATION

| | |
|----------------------|-------------------------|
| Basic Standard | IEC 61000-4-8 |
| Required Performance | A |
| Frequency Range | 50/60 Hz |
| Field Strength | 1 A/m |
| Observation Time | 1 minute |
| Inductance Coil | Rectangular type, 1mx1m |

6.10.2 MEASUREMENT INSTRUMENTS

| Item | Kind of Equipment | Manufacturer | Type No. | Series Model | Calibrated until |
|------|-------------------------------|---------------|----------------------|--------------|------------------|
| 1 | Magnetic Field test Generator | FCC | F-1000-4-8-G-125A | 4032 | Feb. 28, 2022 |
| 2 | Magnetic Field immunity loop | Thermo KeyTek | F-1000-4-8/9/10-L-1M | 4024 | Feb. 28, 2022 |

Remark: "N/A" denotes no model no., no serial No. or no calibration specified.

All calibration period of equipment list is one year.

6.10.3 TEST PROCEDURE

For TABLE-TOP equipment:

The equipment shall be subjected to the test magnetic field by using the induction coil of standard dimension (1 m x 1 m). The induction coil shall then be rotated by 90 degrees in order to expose the EUT to the test field with different orientations.

The other condition as following manner:

- a. The equipment cabinets shall be connected to the safety earth directly on the GRP via the earth terminal of the EUT.
- b. The cables supplied or recommended by the equipment manufacturer shall be used. 1 meter of all cables used shall be exposed to the magnetic field.

6.10.4 DEVIATION FROM TEST STANDARD

No deviation

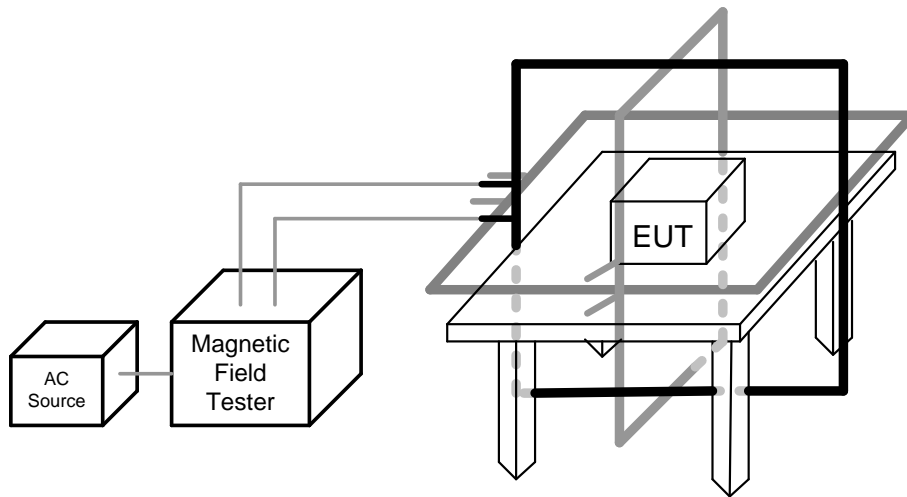
6.10.5 TEST SETUP

6.10.6 TEST RESULTS

| | |
|--------------|---------------------|
| Test Voltage | AC 230V/50Hz |
| Test Mode | Mode 1-6, Mode 9-10 |

50Hz

| Test Mode | Test Level | Antenna aspect | Duration (s) | Criteria | Results |
|-----------|------------|----------------|--------------|----------|---------|
| Enclosure | 1 A/m | X | 60 | A | A |
| Enclosure | 1 A/m | Y | 60 | A | A |
| Enclosure | 1 A/m | Z | 60 | A | A |

60Hz

| Test Mode | Test Level | Antenna aspect | Duration (s) | Criteria | Results |
|-----------|------------|----------------|--------------|----------|---------|
| Enclosure | 1 A/m | X | 60 | A | A |
| Enclosure | 1 A/m | Y | 60 | A | A |
| Enclosure | 1 A/m | Z | 60 | A | A |

6.11 VOLTAGE DIPS, SHORT INTERRUPTIONS AND VOLTAGE VARIATIONS IMMUNITY TEST (DIPS)

6.11.1 TEST SPECIFICATION

| | |
|------------------------|--|
| Basic Standard | IEC 61000-4-11 |
| Required Performance | Voltage dips: B (For <5% residual voltage, dips) C (For 70% residual voltage, dips) C (For <5% residual voltage, Interruptions) |
| Interval between Event | Ten seconds |
| Phase Angle | 0°/180° |
| Test Cycle | 3 times |

6.11.2 MEASUREMENT INSTRUMENTS

| Item | Kind of Equipment | Manufacturer | Type No. | Series Model | Calibrated until |
|------|---------------------|--------------|------------|--------------|------------------|
| 1 | Cycle Sag Simulator | Prima | DRP61011TA | PR19076452 | Dec. 03, 2021 |

Remark: "N/A" denotes no model no., no serial No. or no calibration specified.

All calibration period of equipment list is one year.

6.11.3 TEST PROCEDURE

The EUT shall be tested for each selected combination of test levels and duration with a sequence of three dips/interruptions with intervals of 10 s minimum (between each test event). Each representative mode of operation shall be tested. Abrupt changes in supply voltage shall occur at zero crossings of the voltage waveform.

6.11.4 DEVIATION FROM TEST STANDARD

No deviation

6.11.5 TEST SETUP

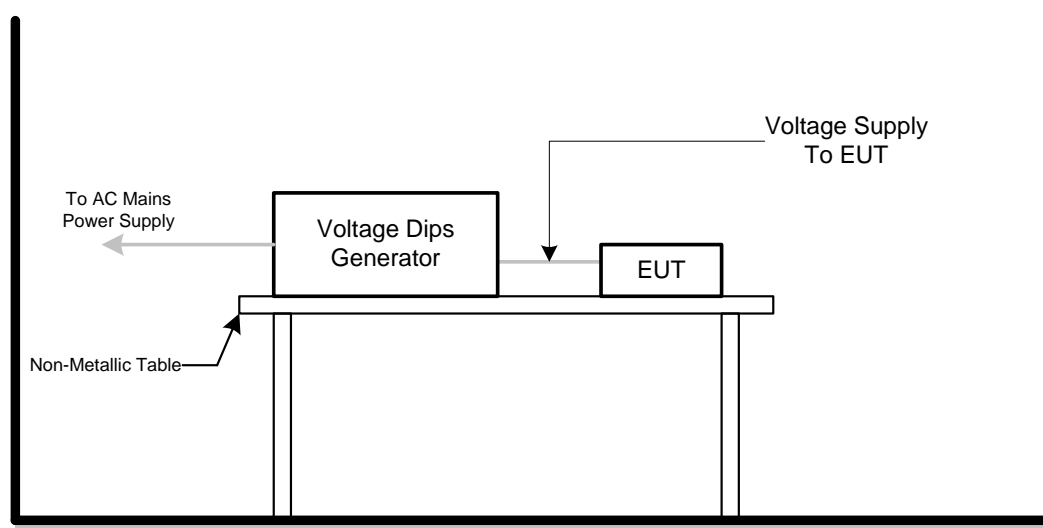

6.11.6 TEST RESULTS

| | |
|--------------|--|
| Test Voltage | AC 100V/50Hz, AC 230V/50Hz, AC 240V/50Hz |
| Test Mode | Mode 1-6, Mode 9-10 |

| AC 100V/50Hz | | | | |
|----------------------|------------------|-------|----------|---------|
| Item | Residual Voltage | Cycle | Criteria | Results |
| Voltage dips | <5% | 0.5 | B | A |
| Voltage dips | 70% | 25 | C | A |
| Voltage Interruption | <5% | 250 | C | C |

| AC 230V/50Hz | | | | |
|----------------------|------------------|-------|----------|---------|
| Item | Residual Voltage | Cycle | Criteria | Results |
| Voltage dips | <5% | 0.5 | B | A |
| Voltage dips | 70% | 25 | C | A |
| Voltage Interruption | <5% | 250 | C | C |

| AC 240V/50Hz | | | | |
|----------------------|------------------|-------|----------|---------|
| Item | Residual Voltage | Cycle | Criteria | Results |
| Voltage dips | <5% | 0.5 | B | A |
| Voltage dips | 70% | 25 | C | A |
| Voltage Interruption | <5% | 250 | C | C |

7. EUT TEST PHOTO

EN 55032: 2015

Radiated emissions up to 1 GHz

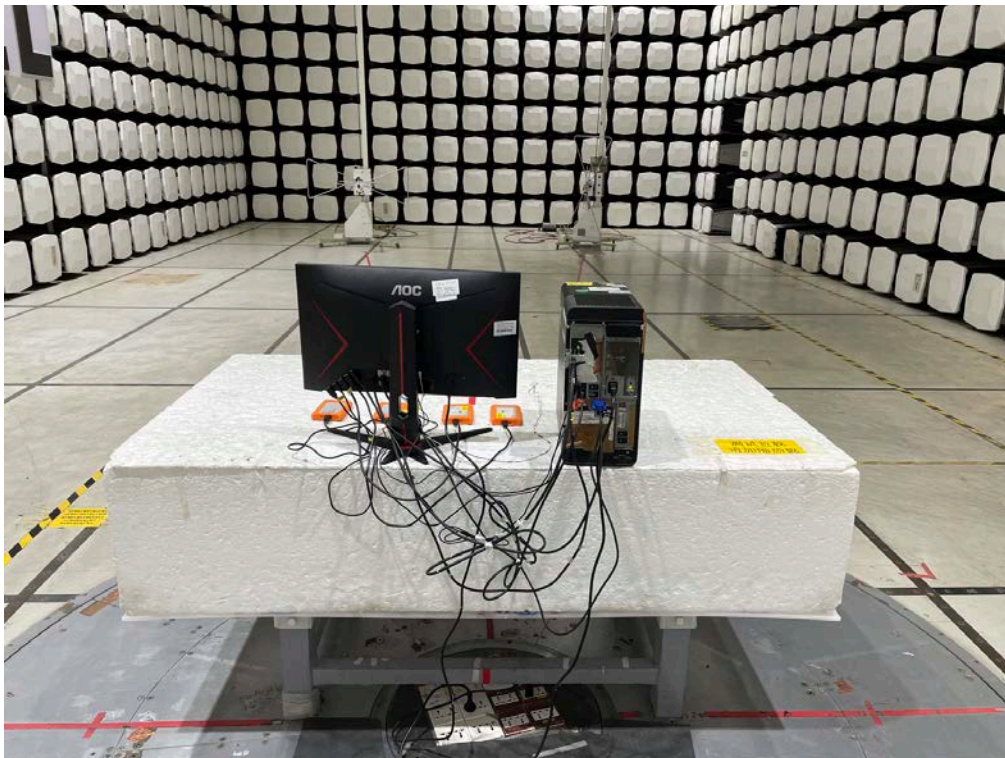
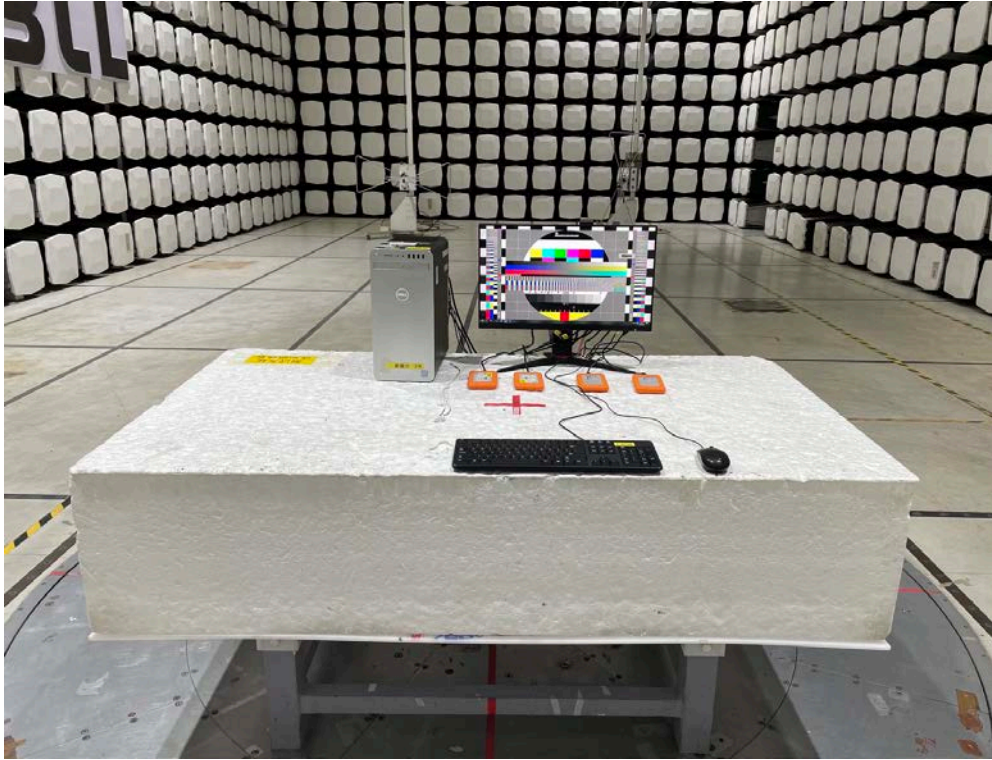

Radiated emissions above 1 GHz

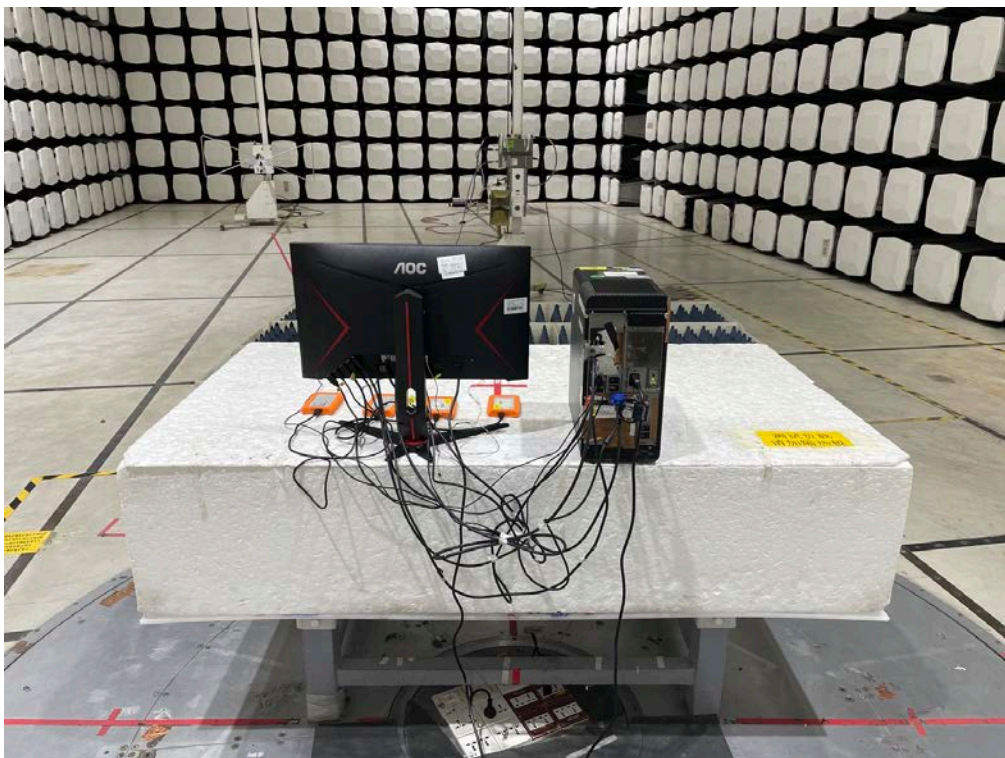
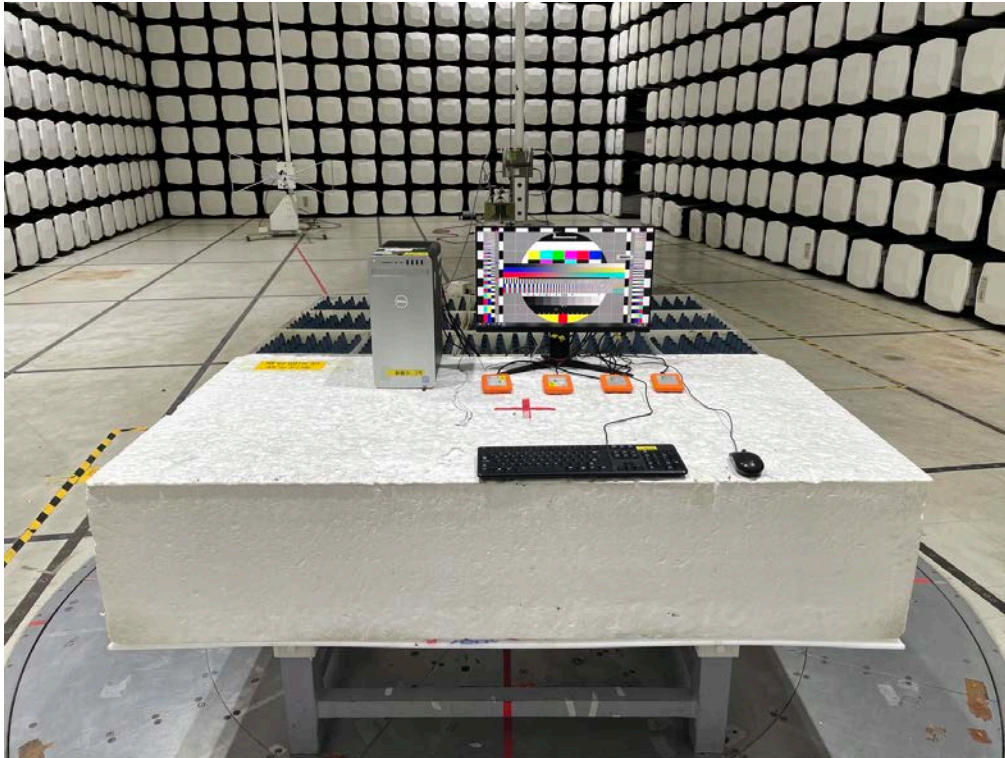

Conducted emissions AC mains power port



EN 55032:2015+AC:2016

Radiated emissions up to 1 GHz

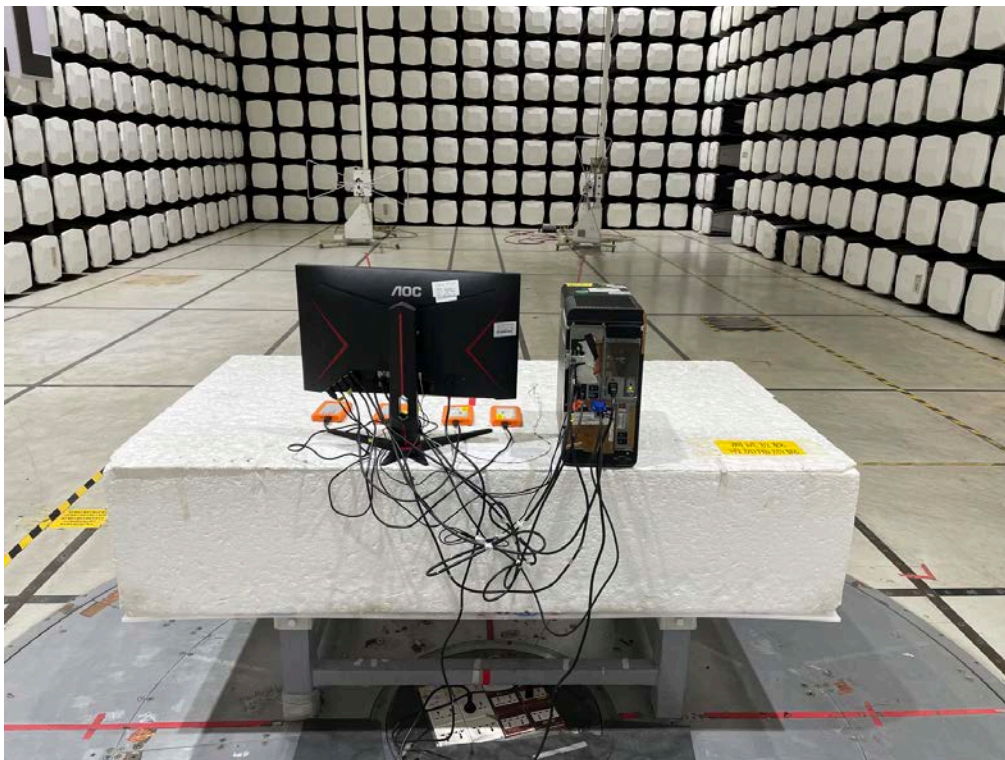

Radiated emissions above 1 GHz

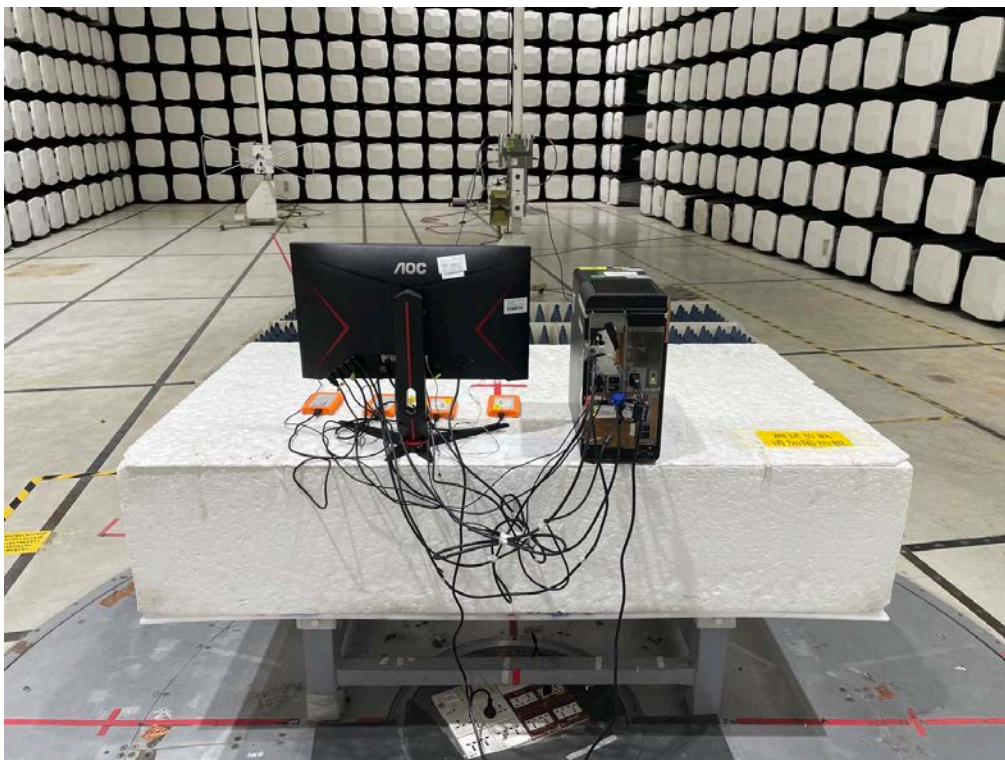
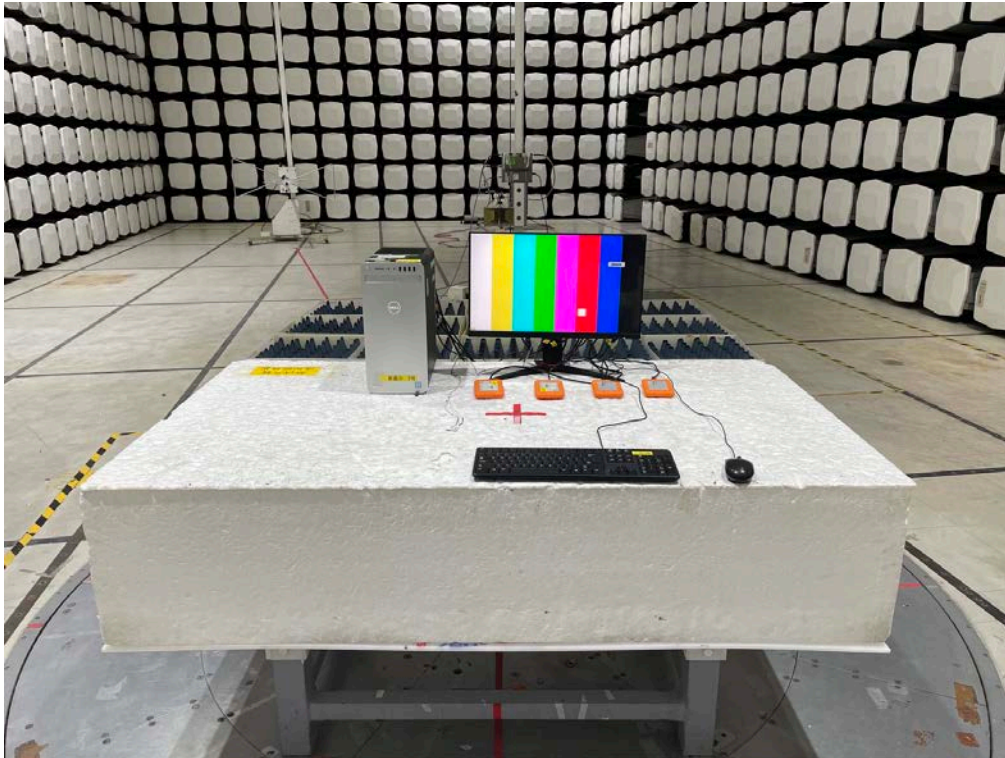

Conducted emissions AC mains power port



Harmonic current emissions



Voltage fluctuations (Flicker)



Electrostatic discharge immunity



Radiated, radio-frequency, electromagnetic field immunity – up to 1GHz

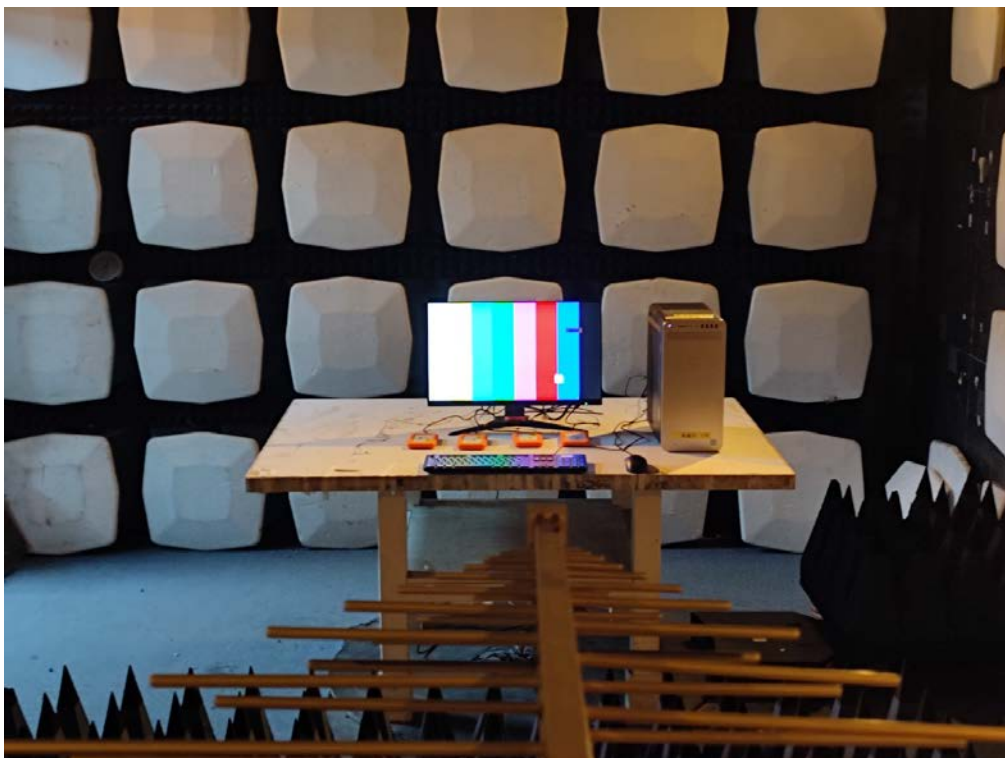

Radiated, radio-frequency, electromagnetic field immunity – above 1GHz



Electrical fast transient/burst immunity



Surge immunity



Immunity to conducted disturbances, induced by radio-frequency fields

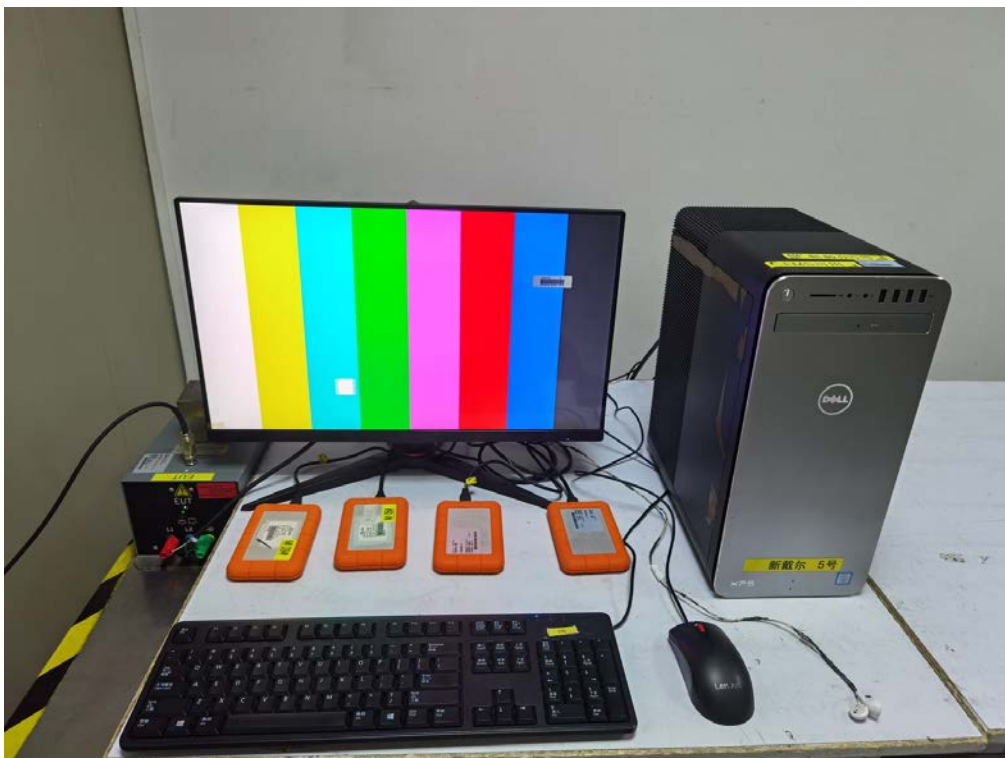

Power frequency magnetic field immunity

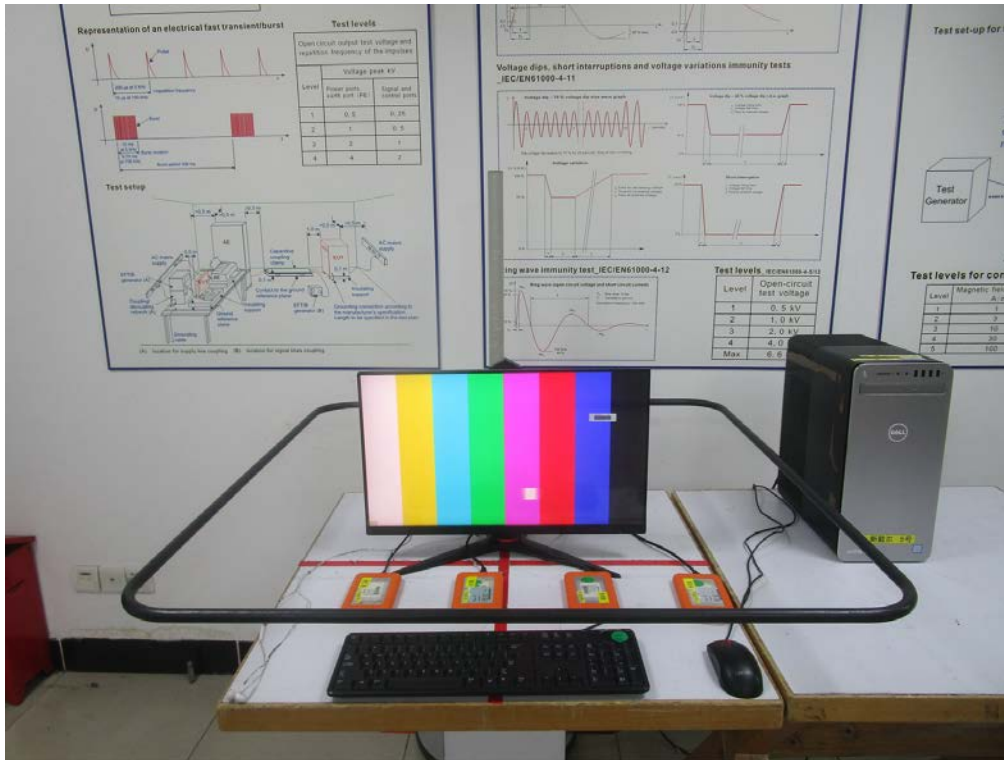

Voltage dips, short interruptions and voltage variations immunity



End of Test Report