



# EMC TEST REPORT

Authorized under Declaration of Conformity

According to

|                                  |                                      |
|----------------------------------|--------------------------------------|
| EN 55032: 2012+AC 2013 (Class B) | EN 55024 : 2010                      |
| EN 61000-3-2 : 2014              | IEC 61000-4-2 : 2008                 |
| EN 61000-3-3 : 2013              | IEC 61000-4-3 : 2006+A1:2007+A2:2010 |
| CISPR 32 : 2015                  | IEC 61000-4-4 : 2012                 |
| AS/NZS CISPR 32 : 2013           | IEC 61000-4-5 : 2014                 |
|                                  | IEC 61000-4-6 : 2013                 |
|                                  | IEC 61000-4-8 : 2009                 |
|                                  | IEC 61000-4-11 : 2004                |

Applicant : TPV Electronics (Fujian) Co., Ltd.  
Address : Rongqiao Economic and Technological  
Development Zone, Fuqing City, Fujian Province,  
P.R. China  
Equipment : LCD Monitor  
238LM00023; I2490\*\*\*  
Model No. : (The “\*” could be any alphanumeric character  
including blank for marketing differentiation.)

## I HEREBY CERTIFY THAT :

The sample was received on Mar 16, 2017 and the testing was carried out on Mar 23, 2017 at CerpPASS Technology Corp. The test result refers exclusively to the test presented test model / sample. Without written approval of CerpPASS Technology Corp., the test report shall not be reproduced except in full.



# EMC TEST REPORT

Issued by:

**CerpPASS Technology (Suzhou) Co.,Ltd**

**No.66,Tangzhuang Road, Suzhou Industrial Park, Jiangsu 215006, China**

**Tel:86-512-6917-5888**

**Fax:86-512-6917-5666**

The test record, data evaluation & Equipment Under Test configurations represented herein are true and accurate accounts of the measurements of the samples EMC characteristics under the conditions specified in this report.

The above equipment was tested by CerpPASS Technology Corp. for compliance with the requirements of technical standards specified above under the EMC Directive. The results of testing in this report apply only to the product/system, which was tested. Other similar equipment will not necessarily produce the same results due to production tolerance and measurement uncertainties

Approved by:

Miro Chueh  
EMC/RF B.U. Manager

Laboratory Accreditation:

CerpPASS Technology Corporation Test Laboratory

|                        |                 |
|------------------------|-----------------|
| <b>NVLAP LAB Code:</b> | <b>200954-0</b> |
| <b>TAF LAB Code:</b>   | <b>1439</b>     |

CerpPASS Technology(SuZhou) Co., Ltd.

|                        |                 |
|------------------------|-----------------|
| <b>NVLAP LAB Code:</b> | <b>200814-0</b> |
| <b>CNAS LAB Code:</b>  | <b>L5515</b>    |



## Contents

|  |           |
|--|-----------|
| <b>1. Summary of Test Procedure and Test Results</b>       | <b>6</b>  |
| <b>2. Immunity Testing Performance Criteria Definition</b> | <b>7</b>  |
| <b>3. Test Configuration of Equipment under Test</b>       | <b>8</b>  |
| 3.1. Feature of Equipment under Test                       | 8         |
| 3.2. Test Manner   | 9         |
| 3.3. Description of Support Unit                           | 11        |
| 3.4. General Information of Test                           | 12        |
| 3.5. Measurement Uncertainty                               | 13        |
| <b>4. Test of Conducted Emission</b>                       | <b>15</b> |
| 4.1. Test Limit  | 15        |
| 4.2. Test Procedures                                       | 18        |
| 4.3. Typical Test Setup                                    | 18        |
| 4.4. Measurement Equipment                                 | 19        |
| 4.5. Test Result and Data                                  | 20        |
| 4.6. Test Photographs of Power Port                        | 33        |
| <b>5. Test of Radiated Emission</b>                        | <b>34</b> |
| 5.1. Test Limit  | 34        |
| 5.2. Test Procedures                                       | 37        |
| 5.3. Typical Test Setup                                    | 37        |
| 5.4. Measurement Equipment                                 | 38        |
| 5.5. Test Result and Data (30MHz ~ 1GHz)                   | 39        |
| 5.6. Test Result and Data (1GHz ~ 6GHz)                    | 51        |
| 5.7. Test Photographs (30MHz~1GHz)                         | 63        |
| 5.8. Test Photographs (1GHz~6GHz)                          | 64        |
| <b>6. Harmonics Test</b>                                   | <b>65</b> |
| 6.1. Limits of Harmonics Current Measurement               | 65        |
| 6.2. Measurement Equipment                                 | 66        |
| 6.3. Test Result and Data                                  | 67        |
| 6.4. Test Photographs                                      | 69        |
| <b>7. Voltage Fluctuations Test</b>                        | <b>70</b> |
| 7.1. Test Procedure  | 70        |
| 7.2. Measurement Equipment                                 | 70        |
| 7.3. Test Result and Data                                  | 71        |
| 7.4. Test Photographs                                      | 73        |
| <b>8. Electrostatic Discharge Immunity Test</b>            | <b>74</b> |
| 8.1. Test Procedure  | 74        |
| 8.2. Test Setup for Tests Performed in Laboratory          | 75        |
| 8.3. Test Severity Levels                                  | 76        |
| 8.4. Measurement Equipment                                 | 76        |
| 8.5. Test Result and Data                                  | 77        |
| 8.6. Test Photographs                                      | 78        |



- 9. Radio Frequency electromagnetic field immunity test ..... 79**
  - 9.1. Test Procedure ..... 79
  - 9.2. Test Severity Levels ..... 79
  - 9.3. TEST SETUP ..... 80
  - 9.4. Measurement Equipment..... 81
  - 9.5. Test Result and Data ..... 82
  - 9.6. Test Photographs ..... 83
- 10. Electrical Fast Transient/ Burst Immunity Test ..... 84**
  - 10.1. Test Procedure ..... 84
  - 10.2. Test Severity Levels ..... 84
  - 10.3. TEST SETUP ..... 85
  - 10.4. Measurement Equipment..... 85
  - 10.5. Test Result and Data ..... 86
  - 10.6. Test Photographs ..... 87
- 11. Surge Immunity Test ..... 88**
  - 11.1. Test Procedure ..... 88
  - 11.2. Test Severity Level ..... 88
  - 11.3. TEST SETUP ..... 89
  - 11.4. Measurement Equipment..... 89
  - 11.5. Test Result and Data ..... 90
  - 11.6. Test Photographs ..... 91
- 12. Conduction Disturbances induced by Radio-Frequency Fields ..... 92**
  - 12.1. Test Procedure ..... 92
  - 12.2. Test Severity Levels ..... 92
  - 12.3. TEST SETUP ..... 93
  - 12.4. Measurement Equipment..... 93
  - 12.5. Test Result and Data ..... 94
  - 12.6. Test Photographs ..... 95
- 13. Power Frequency Magnetic Field Immunity Test ..... 96**
  - 13.1. Test Setup ..... 96
  - 13.2. Test Severity Levels ..... 96
  - 13.3. Measurement Equipment..... 96
  - 13.4. Test Result and Data ..... 97
  - 13.5. Test Photographs ..... 98
- 14. Voltage Dips and Voltage Interruptions Immunity Test Setup ..... 99**
  - 14.1. Test Conditions..... 99
  - 14.2. TEST SETUP ..... 99
  - 14.3. Measurement Equipment..... 99
  - 14.4. Test Result and Data ..... 100
  - 14.5. Test Photographs ..... 101
- 15. Photographs of EUT ..... 102**



### History of this test report

ORIGINAL.

Additional attachment as following record:

| Report No   | Version | Date         | Description   |
|-------------|---------|--------------|---------------|
| SECE1703205 | Rev 01  | Mar 24, 2017 | Initial Issue |
|             |         |              |               |
|             |         |              |               |
|             |         |              |               |
|             |         |              |               |
|             |         |              |               |
|             |         |              |               |
|             |         |              |               |
|             |         |              |               |
|             |         |              |               |
|             |         |              |               |
|             |         |              |               |
|             |         |              |               |
|             |         |              |               |
|             |         |              |               |
|             |         |              |               |
|             |         |              |               |
|             |         |              |               |
|             |         |              |               |
|             |         |              |               |



### 1. Summary of Test Procedure and Test Results

| EMISSION [ EN55032 ]   |                                |        |   |
|--|--------------------------------|--------|---|
| Standard   | Item                           | Result | Remarks   |
| EN55032: 2012+AC 2013<br>AS/NZS CISPR 32 : 2013<br>CISPR 32 : 2015 | Conducted (Power Port)         | PASS   | Meet Class B Limit<br>Minimum passing margin(AV) is -9.47 dB at 0.7260 MHz    |
|  | Conducted (Telecom port)       | N/A    | N/A   |
|  | Radiated                       | PASS   | Meets Class B Limit<br>Minimum passing margin(QP) is -4.02 dB at 282.1999 MHz |
| EN 61000-3-2: 2014   | Harmonic current emissions     | PASS   | Meet Class D Limit  |
| EN61000-3-3:2013   | Voltage fluctuations & flicker | PASS   | Meets the requirements  |

| IMMUNITY [EN 55024:2010]               |                                   |        |  |
|--|-----------------------------------|--------|--|
| Standard                               | Item                              | Result | Remarks  |
| IEC 61000-4-2: 2008                    | ESD                               | PASS   | Meets the requirements of Performance Criterion A  |
| IEC 61000-4-3:<br>2006+A1:2007+A2:2010 | RS                                | PASS   | Meets the requirements of Performance Criterion A  |
| IEC 61000-4-4: 2012                    | EFT                               | PASS   | Meets the requirements of Performance Criterion A  |
| IEC 61000-4-5:2014                     | Surge                             | PASS   | Meets the requirements of Performance Criterion A  |
| IEC 61000-4-6:2013                     | CS                                | PASS   | Meets the requirements of Performance Criterion A  |
| IEC 61000-4-8:2009                     | PFMF                              | PASS   | Meets the requirements of Performance Criterion A  |
| IEC 61000-4-11:2004                    | Voltage dips & voltage variations | PASS   | Meets the requirements of<br>Voltage Dips:<br>1) >95% reduction Performance Criterion B<br>2) 30% reduction Performance Criterion B<br><br>Voltage Interruptions:<br>1) >95% reduction Performance Criterion C |



## 2. Immunity Testing Performance Criteria Definition

|                    |  |
|--------------------|--|
| <b>Criteria A:</b> | The apparatus shall continue to operate as intended without operator intervention. No degradation of performance or loss of function is allowed below a performance level specified by the manufacturer, when the apparatus is used as intended. The performance level may be replaced by a permissible loss of performance. If the manufacturer does not specify the minimum performance level or the permissible performance loss, then either of these may be derived from the product description and documentation, and by what the user may reasonably expect from the equipment if used as intended.  |
| <b>Criteria B:</b> | After test, the apparatus shall continue to operate as intended without operator intervention. No degradation of performance or loss of function is allowed, after the application of the phenomenon below a performance level specified by the manufacturer, when the apparatus is used as intended. The performance level may be replaced by a permissible loss of performance.<br><br>During the test, degradation of performance is however allowed. However, no change of operating state if stored data is allowed to persist after the test. If the manufacturer does not specify the minimum performance level or the permissible performance loss, then either of these may be derived from the product description and documentation, and by what the user may reasonably expect from the equipment if used as intended. |
| <b>Criteria C:</b> | Temporary loss of function is allowed, provided the functions is self-recoverable or can be restored by the operation of controls by the user in accordance with the manufacturer instructions.<br><br>Functions, and/or information stored in non-volatile memory, or protected by a battery backup, shall not be lost.   |



### 3. Test Configuration of Equipment under Test

#### 3.1. Feature of Equipment under Test

|                               |  |
|-------------------------------|--|
| <b>Product Name:</b>          | LCD Monitor  |
| <b>Model Name:</b>            | 238LM00023; I2490***<br>(The "*" could be any alphanumeric character including blank for marketing differentiation.) |
| <b>Housing material:</b>      | Plastic case   |
| <b>EUT Highest Frequency:</b> | 170MHz   |
| <b>EUT Power Rating:</b>      | Input:100-240V,50-60Hz<br>3Pin Power Port  |
| <b>AC Power Cord Type:</b>    | Non-shielded, 1.2m&1.5m&1.8m   |

Note: Please refer to user manual.

#### I/O PORT:

| I/O PORT TYPE     | Quantity |
|-------------------|----------|
| 1). HDMI Port     | 1        |
| 2). DP Port       | 1        |
| 3). VGA Port      | 1        |
| 4). Audio Port    | 2        |
| 5). AC Power Port | 1        |





### 3.2. Test Manner

- a. During testing, the interface cables and equipment positions were varied according to Europe Standard .
- b. An executive program, “MyHwin” under Win 7, which generates a complete line of continuously repeating “H” pattern was used as the test software.

The program was executed as follows:

1. Turn on the power of all equipment.
2. The EUT reads the test program from the hard disk drive and runs it.
3. PC sends “H” messages to the EUT, and the monitor displays “H” patterns on the screen.
4. Run the Color bars.
5. Repeat the steps from 2 to 4.

- c. The complete test system included Computer, USB Keyboard, USB Mouse, Earphone and EUT for EMI&EMS test.

- d. The test modes for CE/RE as follow

|              |  |
|--------------|--|
| Test Mode 1  | Full system (HDMI mode 2560*1440@60Hz) Signal from PC (230V/50Hz)    |
| Test Mode 2  | Full system (HDMI mode 1280*1024@75Hz) Signal from PC (230V/50Hz)    |
| Test Mode 3  | Full system (HDMI mode 640*480@60Hz) Signal from PC (230V/50Hz)      |
| Test Mode 4  | Full system (HDMI mode 1080P) Signal from DVD (230V/50Hz)            |
| Test Mode 5  | Full system (VGA mode 1920*1080@60Hz) Signal from PC (230V/50Hz)     |
| Test Mode 6  | Full system (VGA mode 1280*1024@75Hz) Signal from PC (230V/50Hz)     |
| Test Mode 7  | Full system (VGA mode 640*480@60Hz) Signal from PC (230V/50Hz)       |
| Test Mode 8  | Full system (DISPLAY mode 2560*1440@60Hz) Signal from PC (230V/50Hz) |
| Test Mode 9  | Full system (DISPLAY mode 1280*1024@75Hz) Signal from PC (230V/50Hz) |
| Test Mode 10 | Full system (DISPLAY mode 640*480@60Hz) Signal from PC (230V/50Hz)   |
| Test Mode 11 | Full system (HDMI mode 2560*1440@60Hz) Signal from PC (110V/60Hz)    |
| Test Mode 12 | Full system (VGA mode 1920*1080@60Hz) Signal from PC (110V/60Hz)     |
| Test Mode 13 | Full system (DISPLAY mode 2560*1440@60Hz) Signal from PC (110V/60Hz) |

“Test mode 1,5,8,11,12,13” were reported as final data.

- e. The test modes for EMS H&F as follow

|             |   |
|-------------|---|
| Test Mode 1 | Full system (HDMI mode 2560*1440@60Hz) Signal from PC |
| Test Mode 2 | Full system (HDMI mode 1280*1024@75Hz) Signal from PC |
| Test Mode 3 | Full system (HDMI mode 640*480@60Hz) Signal from PC   |
| Test Mode 4 | Full system (HDMI mode 1080P) Signal from DVD         |
| Test Mode 5 | Full system (VGA mode 1920*1080@60Hz) Signal from PC  |
| Test Mode 6 | Full system (VGA mode 1280*1024@75Hz) Signal from PC  |
| Test Mode 7 | Full system (VGA mode 640*480@60Hz) Signal from PC    |



Test Mode 8 Full system (Display mode 2560\*1440@60Hz) Signal from PC  
Test Mode 9 Full system (Display mode 1280\*1024@75Hz) Signal from PC  
Test Mode 10 Full system (Display mode 640\*480@60Hz) Signal from PC

“Test mode 1,5,8” were reported as final data.

- f. The maximum operating frequency is above 108MHz, the test frequency range is from 1GHz to 6GHz.



### 3.3. Description of Support Unit

| No. | Device       | Manufacturer | Model No.                 | Description                 |
|-----|--------------|--------------|---------------------------|-----------------------------|
| 1   | Computer     | HP           | HP Compaq Elite 8200 MTPC | Non-Shielded ,1.8m (R33001) |
| 2   | USB Keyboard | DELL         | SK-8115                   | T3A002                      |
| 3   | USB Mouse    | DELL         | G0K02XYK                  | R41108                      |
| 4   | Earphone     | Salar        | V81                       | N/A                         |

| No. | Cable         | Quantity | Description                                  |
|-----|---------------|----------|--|
| A   | USB Cable     | 1        | Shielded, 1.8m, with one ferrite core bonded |
| B   | USB Cable     | 1        | Shielded, 1.2m                               |
| C   | Audio Cable   | 1        | Non-Shielded, 1.8m                           |
| D   | HDMI Cable    | 1        | Shielded, 1.2m&1.5m&1.8m with two core       |
| E   | VGA Cable     | 1        | Shielded, 1.2m&1.5m&1.8m with two core       |
| F   | DISPLAY Cable | 1        | Shielded, 1.2m&1.5m&1.8m                     |
| G   | Audio Cable   | 1        | Shielded, 1.2m&1.5m&1.8m                     |



**3.4. General Information of Test**

|                                     |           |  |
|-------------------------------------|-----------|--|
| <input type="checkbox"/>            | Test Site | <p><b>CerpPASS Technology Corporation Test Laboratory</b><br/>                 Address: No.10, Ln. 2, Lianfu St., Luzhu Dist., Taoyuan City 33848, Taiwan (R.O.C.)<br/>                 Tel:+886-3-3226-888<br/>                 Fax:+886-3-3226-881<br/>                 Address: No.68-1, Shihbachongsi, Shihding Township, New Taipei City 223, Taiwan, R.O.C.<br/>                 Tel: +886-2-2663-8582</p> |
|                                     | FCC       | TW1079, TW1061,390316, 228391, 641184  |
|                                     | IC        | 4934B-1, 4934E-1, 4934E-2  |
|                                     | VCCI      | T-2205 for Telecommunication Test<br>C-4663 for Conducted emission test<br>R-3428, R-4218 for Radiated emission test<br>G-812, G-813 for radiated disturbance above 1GHz   |
| <input checked="" type="checkbox"/> | Test Site | <p><b>CerpPASS Technology (Suzhou) Co.,Ltd</b><br/>                 Address: No.66,Tangzhuang Road, Suzhou Industrial Park, Jiangsu 215006, China<br/>                 Tel: +86-512-6917-5888<br/>                 Fax: +86-512-6917-5666</p>  |
|                                     | FCC       | 331395   |
|                                     | IC        | 7290A-1, 7290A-2   |
|                                     | VCCI      | T-1945 for Telecommunication Test<br>C-2919 for Conducted emission test<br>R-2670 for Radiated emission test<br>G-227 for radiated disturbance above 1GHz  |
| Frequency Range Investigated:       |           | Conducted: from 150kHz to 30 MHz<br>Radiation: from 30 MHz to 6000MHz  |
| Test Distance :                     |           | The test distance of radiated emission below 1GHz from antenna to EUT is 10 M.<br>The test distance of radiated emission above 1GHz from antenna to EUT is 3 M.  |



### 3.5. Measurement Uncertainty

Where relevant, the following measurement uncertainty levels have been estimated for tests performed on the EUT as specified in CISPR 16-4-2:

| Measurement                  | Frequency  | Uncertainty   |
|------------------------------|------------|---------------|
| Conducted emissions(LINE)    | 9KHz-30MHz | +/- 0.7738 dB |
| Conducted emissions(NEUTRAL) | 9KHz-30MHz | +/- 0.7886 dB |

| Measurement                        | Polarity | Frequency          | Uncertainty   |
|------------------------------------|----------|--------------------|---------------|
| Radiated emissions<br>(below 1GHz) | H        | 30MHz ~ 200MHz     | +/- 3.8909dB  |
|                                    |          | 200MHz ~1000MHz    | +/- 3.6555dB  |
|                                    | V        | 30MHz ~ 200MHz     | +/- 3.8948dB  |
|                                    |          | 200MHz ~1000MHz    | +/- 3.6538dB  |
| Radiated emissions<br>(above 1GHz) | H        | 1000MHz ~18000MHz  | +/- 3.8948 dB |
|                                    |          | 18000MHz ~40000MHz | +/-3.8844dB   |
|                                    | V        | 1000MHz ~18000MHz  | +/- 3.8906dB  |
|                                    |          | 18000MHz ~40000MHz | +/- 3.8744dB  |

| Measurement           | Uncertainty |
|-----------------------|-------------|
| ESD—Rise time tr      | 10%         |
| ESD—Peak current Ip   | 6%          |
| ESD—Current at 30 ns  | 6%          |
| ESD—Current at 60 ns  | 6%          |
| ESD- Charging voltage | 1%          |
| RS above 1GHz         | ±2.37dB     |
| RS under 1GHz         | ±3.83dB     |
| EFT—Rise time tr      | 4%          |
| EFT—Peak current Ip   | 4%          |
| EFT—Current           | 4%          |
| Surge—Rise time tr    | 4%          |



|                          |                     |
|--------------------------|---------------------|
| Surge—Peak current $I_p$ | 4%                  |
| Surge—Current            | 4%                  |
| CS-CND                   | $\pm 0.80\text{dB}$ |
| CS-Clamp                 | $\pm 1.06\text{dB}$ |

This uncertainty represents an expanded uncertainty expressed at approximately the 95% confidence level using a coverage factor of  $k=2$ .

Consistent with industry standard (e.g. CISPR 22: 2008, clause 11, Measurement Uncertainty) determining compliance with the limits shall be based on the results of the compliance measurement. Consequently the measured emissions being less than the maximum allowed emission result in this being a compliant test or passing test.



## 4. Test of Conducted Emission

### 4.1. Test Limit

Conducted Emissions were measured from 150 kHz to 30 MHz with a bandwidth of 9 kHz and return leads of the EUT according to the methods defined in European Standard EN 55032.

**Table A.8 – Requirements for conducted emissions from the AC mains power ports of Class A equipment**

| Applicable to   |                     |                                 |                           |                       |
|---|---------------------|---------------------------------|---------------------------|-----------------------|
| 1. AC mains power ports (3.1.1)                             |                     |                                 |                           |                       |
| Table clause  | Frequency range MHz | Coupling device (see Table A.7) | Detector type / bandwidth | Class A limits dB(μV) |
| A8.1  | 0,15 – 0,5          | AMN                             | Quasi Peak / 9 kHz        | 79                    |
|   | 0,5 – 30            |                                 |                           | 73                    |
| A8.2  | 0,15 – 0,5          | AMN                             | Average / 9 kHz           | 66                    |
|   | 0,5 – 30            |                                 |                           | 60                    |
| NOTE Apply A8.1 and A8.2 across the entire frequency range. |                     |                                 |                           |                       |

**Table A.9 – Requirements for conducted emissions from the AC mains power ports of Class B equipment**

| Applicable to   |                     |                                 |                           |                       |
|---|---------------------|---------------------------------|---------------------------|-----------------------|
| 1. AC mains power ports (3.1.1)                             |                     |                                 |                           |                       |
| Table clause  | Frequency range MHz | Coupling device (see Table A.7) | Detector type / bandwidth | Class B limits dB(μV) |
| A9.1  | 0,15 – 0,5          | AMN                             | Quasi Peak / 9 kHz        | 66 – 56               |
|   | 0,5 – 5             |                                 |                           | 56                    |
|   | 5 – 30              |                                 |                           | 60                    |
| A9.2  | 0,15 – 0,5          | AMN                             | Average / 9 kHz           | 56 – 46               |
|   | 0,5 – 5             |                                 |                           | 46                    |
|   | 5 – 30              |                                 |                           | 50                    |
| NOTE Apply A9.1 and A9.2 across the entire frequency range. |                     |                                 |                           |                       |



**Table A.10 – Requirements for asymmetric mode conducted emissions from Class A equipment**

| <b>Applicable to</b>   |                            |  |                                  |                                      |                                      |
|--|----------------------------|--|----------------------------------|--------------------------------------|--------------------------------------|
| 1. wired network ports (3.1.30)<br>2. optical fibre ports (3.1.24) with metallic shield or tension members<br>3. antenna ports (3.1.3)   |                            |  |                                  |                                      |                                      |
| <b>Table clause</b>  | <b>Frequency range MHz</b> | <b>Coupling device (see Table A.7)</b> | <b>Detector type / bandwidth</b> | <b>Class A voltage limits dB(μV)</b> | <b>Class A current limits dB(μA)</b> |
| A10.1  | 0,15 – 0,5                 | AAN                                    | Quasi Peak / 9 kHz               | 97 – 87                              | n/a                                  |
|  | 0,5 – 30                   |  |                                  | 87                                   |                                      |
|  | 0,15 – 0,5                 | AAN                                    | Average / 9 kHz                  | 84 – 74                              |                                      |
|  | 0,5 – 30                   |  |                                  | 74                                   |                                      |
| A10.2  | 0,15 – 0,5                 | CVP and current probe                  | Quasi Peak / 9 kHz               | 97 – 87                              | 53 – 43                              |
|  | 0,5 – 30                   |  |                                  | 87                                   | 43                                   |
|  | 0,15 – 0,5                 | CVP and current probe                  | Average / 9 kHz                  | 84 – 74                              | 40 – 30                              |
|  | 0,5 – 30                   |  |                                  | 74                                   | 30                                   |
| A10.3  | 0,15 – 0,5                 | Current Probe                          | Quasi Peak / 9 kHz               | n/a                                  | 53 – 43                              |
|  | 0,5 – 30                   |  |                                  |                                      | 43                                   |
|  | 0,15 – 0,5                 | Current Probe                          | Average / 9 kHz                  |                                      | 40 – 30                              |
|  | 0,5 – 30                   |  |                                  |                                      | 30                                   |
| NOTE 1 The choice of coupling device and measurement procedure is defined in Annex C.<br>NOTE 2 AC mains power ports shall meet the limits given in Table A.8.<br>NOTE 3 The test shall cover the entire frequency range.<br>NOTE 4 The application of the voltage and/or current limits is dependent on the measurement procedure used. Refer to Table C.1 for applicability.<br>NOTE 5 Testing is required at only one EUT supply voltage and frequency.<br>NOTE 6 Applicable to ports listed above and intended to connect to cables longer than 3 m. |                            |  |                                  |                                      |                                      |





**Table A.11 – Requirements for asymmetric mode conducted emissions from Class B equipment**

| <b>Applicable to</b>   |                            |  |                                  |                                      |                                      |
|--|----------------------------|--|----------------------------------|--------------------------------------|--------------------------------------|
| 1. wired network ports (3.1.30)<br>2. optical fibre ports (3.1.24) with metallic shield or tension members<br>3. broadcast receiver tuner ports (3.1.8)<br>4. antenna ports (3.1.3)  |                            |  |                                  |                                      |                                      |
| <b>Table clause</b>  | <b>Frequency range MHz</b> | <b>Coupling device (see Table A.7)</b> | <b>Detector type / bandwidth</b> | <b>Class B voltage limits dB(μV)</b> | <b>Class B current limits dB(μA)</b> |
| A11.1  | 0,15 – 0,5                 | AAN                                    | Quasi Peak / 9 kHz               | 84 – 74                              | n/a                                  |
|  | 0,5 – 30                   |  |                                  | 74                                   |                                      |
|  | 0,15 – 0,5                 | AAN                                    | Average / 9 kHz                  | 74 – 64                              |                                      |
|  | 0,5 – 30                   |  |                                  | 64                                   |                                      |
| A11.2  | 0,15 – 0,5                 | CVP and current probe                  | Quasi Peak / 9 kHz               | 84 – 74                              | 40 – 30                              |
|  | 0,5 – 30                   |  |                                  | 74                                   | 30                                   |
|  | 0,15 – 0,5                 | CVP and current probe                  | Average / 9 kHz                  | 74 – 64                              | 30 – 20                              |
|  | 0,5 – 30                   |  |                                  | 64                                   | 20                                   |
| A11.3  | 0,15 – 0,5                 | Current Probe                          | Quasi Peak / 9 kHz               | n/a                                  | 40 – 30                              |
|  | 0,5 – 30                   |  |                                  |                                      | 30                                   |
|  | 0,15 – 0,5                 | Current Probe                          | Average / 9 kHz                  |                                      | 30 – 20                              |
|  | 0,5 – 30                   |  |                                  |                                      | 20                                   |
| NOTE 1 The choice of coupling device and measurement procedure is defined in Annex C.<br><br>NOTE 2 Screened ports including TV broadcast receiver tuner ports are tested with a common-mode impedance of 150 Ω. This is typically accomplished with the screen terminated by 150 Ω to earth.<br><br>NOTE 3 AC mains power ports shall meet the limits given in Table A.9.<br><br>NOTE 4 The test shall cover the entire frequency range.<br><br>NOTE 5 The application of the voltage and/or current limits is dependent on the measurement procedure used. Refer to Table C.1 for applicability.<br><br>NOTE 6 Testing is required at only one EUT supply voltage and frequency.<br><br>NOTE 7 Applicable to ports listed above and intended to connect to cables longer than 3 m. |                            |  |                                  |                                      |                                      |

## 4.2. Test Procedures

- The EUT was placed on a desk 0.8 meters height from the metal ground plane and 0.4 meter from the conducting wall of the shielding room and it was kept at least 0.8 meters from any other grounded conducting surface.
- Connect EUT to the power mains through a line impedance stabilization network (LISN).
- All the support units are connecting to the other LISN.
- The LISN provides 50 ohm coupling impedance for the measuring instrument.
- The CISPR states that a 50 ohm, 50 micro-Henry LISN should be used.
- Both sides of AC line were checked for maximum conducted interference.
- The frequency range from 150 kHz to 30 MHz was searched
- Set the test-receiver system to Peak Detect Function and Specified Bandwidth with Maximum Hold Mode.

## 4.3. Typical Test Setup

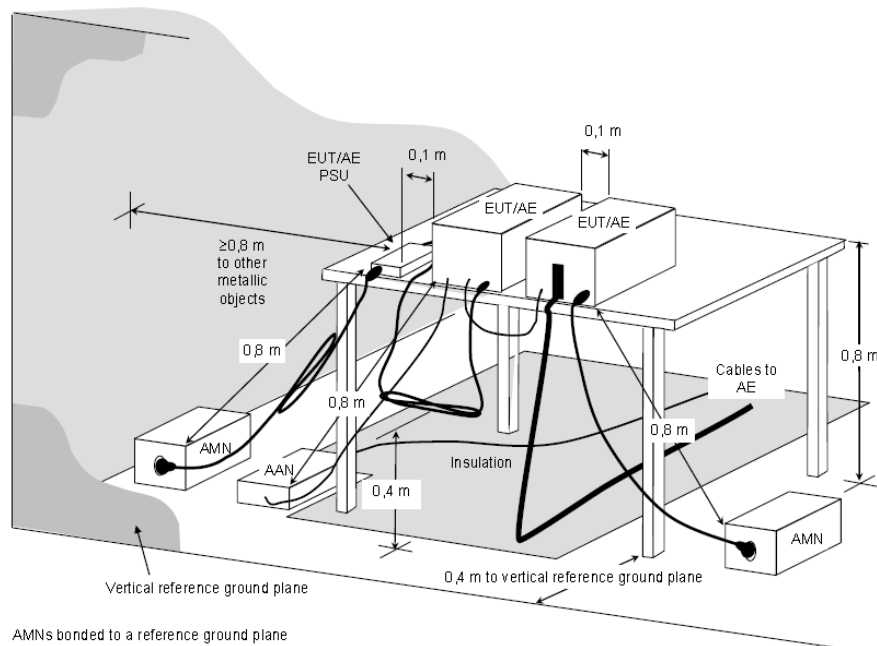

NOTE The 0,8 m distance specified between EUT/AE/PSU and AMN/AAN, is applicable only to the EUT being measured. If the device is AE then it shall be  $\geq 0,8$  m.

**Figure D.2 – Example measurement arrangement for table-top EUT  
(Conducted emission measurement – alternative 1)**



#### 4.4. Measurement Equipment

| Instrument/Ancillary        | Manufacturer | Model No.       | Serial No. | Calibration Date | Valid Date. |
|-----------------------------|--------------|-----------------|------------|------------------|-------------|
| Test Receiver               | R&S          | ESCI            | 100565     | 2016.07.07       | 2017.07.06  |
| AMN                         | R&S          | ESH2-Z5         | 100182     | 2016.08.31       | 2017.08.30  |
| Two-Line V-Network          | R&S          | ENV216          | 100325     | /                | /           |
| ISN                         | FCC          | FCC-TLISN-T2-02 | 20379      | 2016.03.26       | 2017.03.25  |
| ISN                         | FCC          | FCC-TLISN-T4-02 | 20380      | 2016.06.24       | 2017.06.24  |
| ISN                         | FCC          | FCC-TLISN-T8-02 | 20381      | 2016.03.26       | 2017.03.25  |
| ISN                         | TESEQ        | ISN ST08        | 30175      | 2016.03.26       | 2017.03.25  |
| Current Probe               | R&S          | EZ-17           | 100303     | 2016.03.26       | 2017.03.25  |
| Passive Voltage Probe       | R&S          | ESH2-Z3         | 100026     | 2016.03.26       | 2017.03.25  |
| Pulse Limiter               | R&S          | ESH3-Z2         | 100529     | 2016.03.26       | 2017.03.25  |
| Temperature/ Humidity Meter | Zhicheng     | ZC1-11          | CEP-TH-004 | 2016.03.29       | 2017.03.28  |
| EZ-EMC                      | Fala         | Ver CT3A1       | N/A        | N/A              | N/A         |



### 4.5. Test Result and Data

#### 4.5.1 Conducted Emission for Power Port Test Data

|                  |   |            |            |
|------------------|---|------------|------------|
| Test Mode :      | Mode 1: Full system (HDMI mode 2560*1440@60Hz) Signal from PC (230V/50Hz) |            |            |
| AC Power :       | AC 230V/50Hz  | Phase :    | LINE       |
| Equipment :      | LCD Monitor   | Model No : | 238LM00023 |
| Temperature :    | 23°C  | Humidity : | 54%        |
| Pressure(mbar) : | 1001  | Date:      | 2017/03/21 |

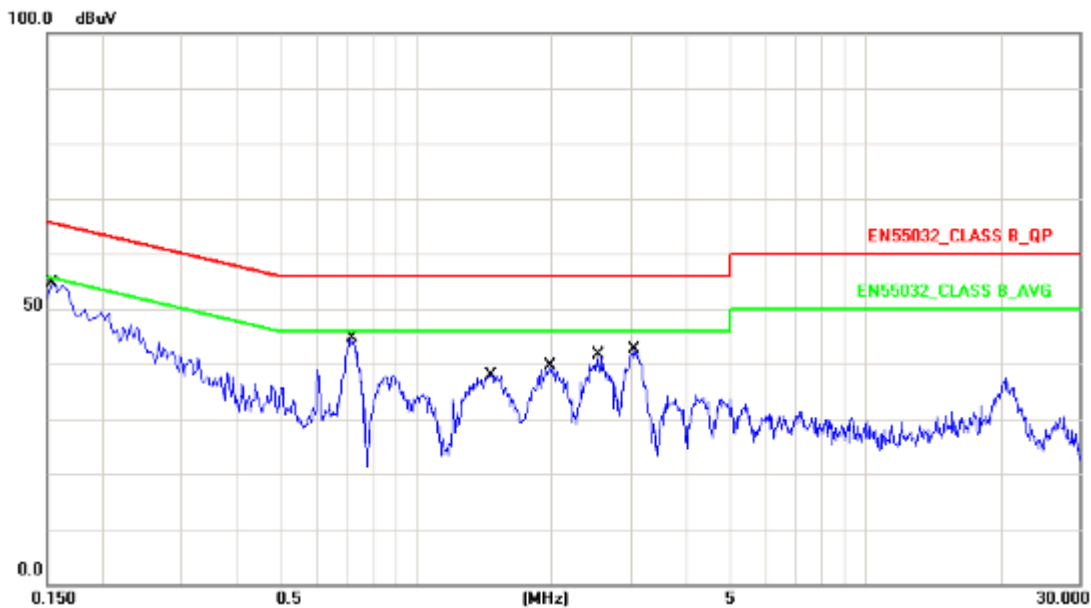

| No. | Frequency (MHz) | Factor (dB) | Reading (dBuV) | Level (dBuV) | Limit (dBuV) | Margin (dB) | Detector |
|-----|-----------------|-------------|----------------|--------------|--------------|-------------|----------|
| 1   | 0.1539          | 10.13       | 40.75          | 50.88        | 65.78        | -14.90      | QP       |
| 2   | 0.1539          | 10.13       | 28.99          | 39.12        | 55.78        | -16.66      | AVG      |
| 3   | 0.7180          | 10.15       | 31.75          | 41.90        | 56.00        | -14.10      | QP       |
| 4   | 0.7180          | 10.15       | 24.72          | 34.87        | 46.00        | -11.13      | AVG      |
| 5   | 1.4700          | 10.16       | 24.17          | 34.33        | 56.00        | -21.67      | QP       |
| 6   | 1.4700          | 10.16       | 18.79          | 28.95        | 46.00        | -17.05      | AVG      |
| 7   | 1.9820          | 10.17       | 25.28          | 35.45        | 56.00        | -20.55      | QP       |
| 8   | 1.9820          | 10.17       | 19.79          | 29.96        | 46.00        | -16.04      | AVG      |
| 9   | 2.5500          | 10.18       | 25.80          | 35.98        | 56.00        | -20.02      | QP       |
| 10  | 2.5500          | 10.18       | 19.04          | 29.22        | 46.00        | -16.78      | AVG      |
| 11  | 3.0620          | 10.19       | 27.64          | 37.83        | 56.00        | -18.17      | QP       |
| 12  | 3.0620          | 10.19       | 18.22          | 28.41        | 46.00        | -17.59      | AVG      |

Note: Measurement Level = Reading Level + Correct Factor



|                  |   |            |            |
|------------------|---|------------|------------|
| Test Mode :      | Mode 1: Full system (HDMI mode 2560*1440@60Hz) Signal from PC (230V/50Hz) |            |            |
| AC Power :       | AC 230V/50Hz  | Phase :    | NEUTRAL    |
| Equipment :      | LCD Monitor   | Model No : | 238LM00023 |
| Temperature :    | 23°C  | Humidity : | 54%        |
| Pressure(mbar) : | 1001  | Date:      | 2017/03/21 |

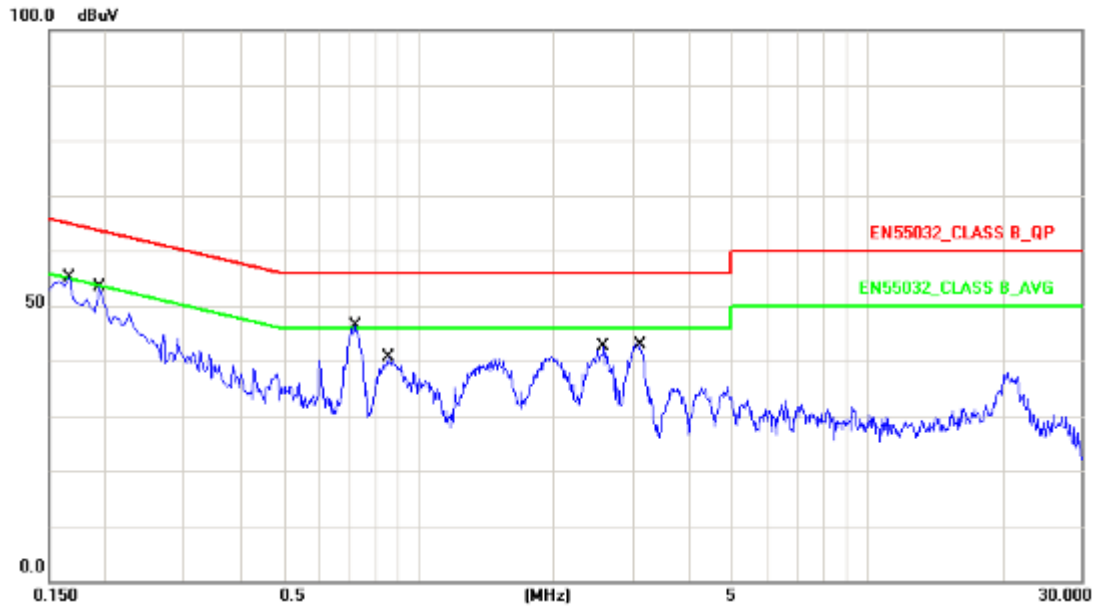

| No. | Frequency (MHz) | Factor (dB) | Reading (dBuV) | Level (dBuV) | Limit (dBuV) | Margin (dB) | Detector |
|-----|-----------------|-------------|----------------|--------------|--------------|-------------|----------|
| 1   | 0.1660          | 10.13       | 38.34          | 48.47        | 65.15        | -16.68      | QP       |
| 2   | 0.1660          | 10.13       | 25.57          | 35.70        | 55.15        | -19.45      | AVG      |
| 3   | 0.1940          | 10.13       | 36.43          | 46.56        | 63.86        | -17.30      | QP       |
| 4   | 0.1940          | 10.13       | 25.02          | 35.15        | 53.86        | -18.71      | AVG      |
| 5   | 0.7260          | 10.16       | 32.74          | 42.90        | 56.00        | -13.10      | QP       |
| 6   | 0.7260          | 10.16       | 26.37          | 36.53        | 46.00        | -9.47       | AVG      |
| 7   | 0.8540          | 10.17       | 26.95          | 37.12        | 56.00        | -18.88      | QP       |
| 8   | 0.8540          | 10.17       | 20.63          | 30.80        | 46.00        | -15.20      | AVG      |
| 9   | 2.5900          | 10.19       | 26.66          | 36.85        | 56.00        | -19.15      | QP       |
| 10  | 2.5900          | 10.19       | 19.90          | 30.09        | 46.00        | -15.91      | AVG      |
| 11  | 3.1180          | 10.20       | 27.34          | 37.54        | 56.00        | -18.46      | QP       |
| 12  | 3.1180          | 10.20       | 18.30          | 28.50        | 46.00        | -17.50      | AVG      |

Note: Measurement Level = Reading Level + Correct Factor



|                  |  |            |            |
|------------------|--|------------|------------|
| Test Mode :      | Mode 5: Full system (VGA mode 1920*1080@60Hz) Signal from PC (230V/50Hz) |            |            |
| AC Power :       | AC 230V/50Hz   | Phase :    | LINE       |
| Equipment :      | LCD Monitor  | Model No : | 238LM00023 |
| Temperature :    | 23°C   | Humidity : | 54%        |
| Pressure(mbar) : | 1001   | Date:      | 2017/03/21 |

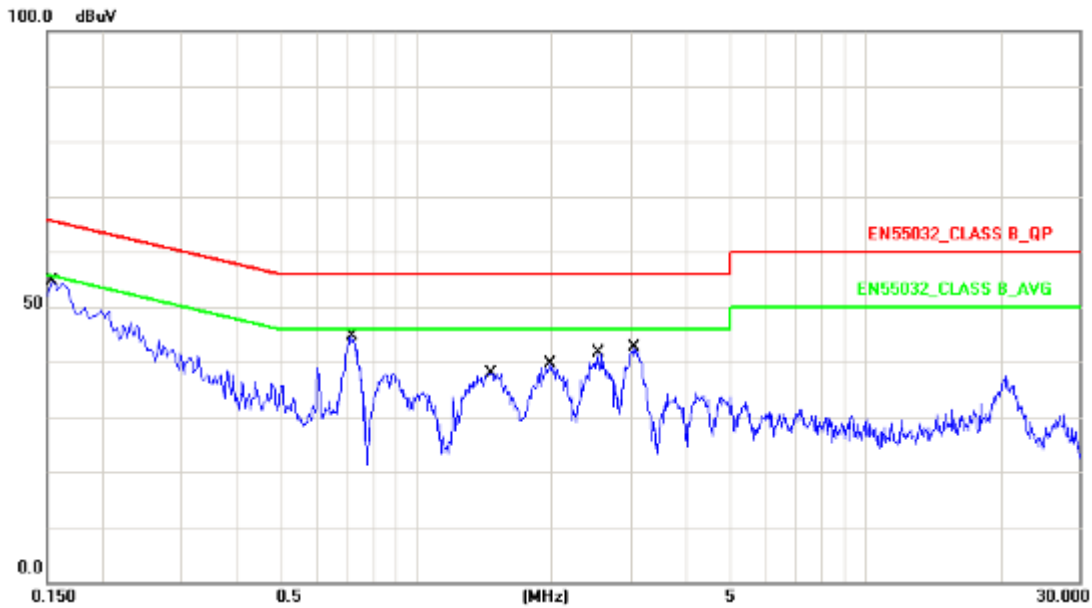

| No. | Frequency (MHz) | Factor (dB) | Reading (dBuV) | Level (dBuV) | Limit (dBuV) | Margin (dB) | Detector |
|-----|-----------------|-------------|----------------|--------------|--------------|-------------|----------|
| 1   | 0.1539          | 10.13       | 40.75          | 50.88        | 65.78        | -14.90      | QP       |
| 2   | 0.1539          | 10.13       | 28.99          | 39.12        | 55.78        | -16.66      | AVG      |
| 3   | 0.7180          | 10.15       | 31.75          | 41.90        | 56.00        | -14.10      | QP       |
| 4   | 0.7180          | 10.15       | 24.72          | 34.87        | 46.00        | -11.13      | AVG      |
| 5   | 1.4700          | 10.16       | 24.17          | 34.33        | 56.00        | -21.67      | QP       |
| 6   | 1.4700          | 10.16       | 18.79          | 28.95        | 46.00        | -17.05      | AVG      |
| 7   | 1.9820          | 10.17       | 25.28          | 35.45        | 56.00        | -20.55      | QP       |
| 8   | 1.9820          | 10.17       | 19.79          | 29.96        | 46.00        | -16.04      | AVG      |
| 9   | 2.5500          | 10.18       | 25.80          | 35.98        | 56.00        | -20.02      | QP       |
| 10  | 2.5500          | 10.18       | 19.04          | 29.22        | 46.00        | -16.78      | AVG      |
| 11  | 3.0620          | 10.19       | 27.64          | 37.83        | 56.00        | -18.17      | QP       |
| 12  | 3.0620          | 10.19       | 18.22          | 28.41        | 46.00        | -17.59      | AVG      |

Note: Measurement Level = Reading Level + Correct Factor



|                  |  |            |            |
|------------------|--|------------|------------|
| Test Mode :      | Mode 5: Full system (VGA mode 1920*1080@60Hz) Signal from PC (230V/50Hz) |            |            |
| AC Power :       | AC 230V/50Hz   | Phase :    | NEUTRAL    |
| Equipment :      | LCD Monitor  | Model No : | 238LM00023 |
| Temperature :    | 23°C   | Humidity : | 54%        |
| Pressure(mbar) : | 1001   | Date:      | 2017/03/21 |

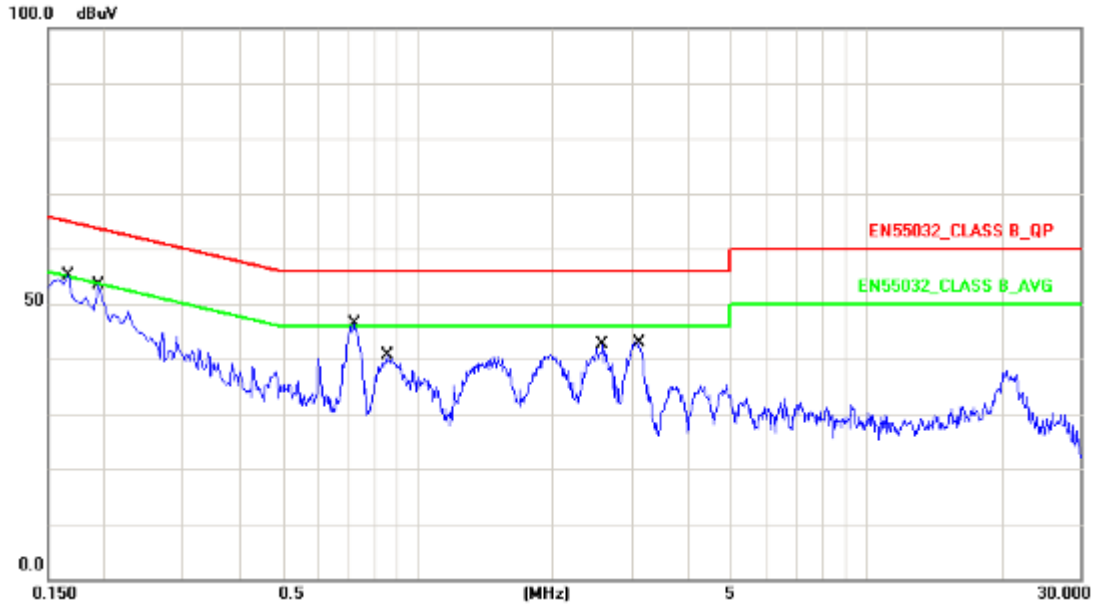

| No. | Frequency (MHz) | Factor (dB) | Reading (dBuV) | Level (dBuV) | Limit (dBuV) | Margin (dB) | Detector |
|-----|-----------------|-------------|----------------|--------------|--------------|-------------|----------|
| 1   | 0.1660          | 10.13       | 38.34          | 48.47        | 65.15        | -16.68      | QP       |
| 2   | 0.1660          | 10.13       | 25.57          | 35.70        | 55.15        | -19.45      | AVG      |
| 3   | 0.1940          | 10.13       | 36.43          | 46.56        | 63.86        | -17.30      | QP       |
| 4   | 0.1940          | 10.13       | 25.02          | 35.15        | 53.86        | -18.71      | AVG      |
| 5   | 0.7260          | 10.16       | 32.74          | 42.90        | 56.00        | -13.10      | QP       |
| 6   | 0.7260          | 10.16       | 26.37          | 36.53        | 46.00        | -9.47       | AVG      |
| 7   | 0.8540          | 10.17       | 26.95          | 37.12        | 56.00        | -18.88      | QP       |
| 8   | 0.8540          | 10.17       | 20.63          | 30.80        | 46.00        | -15.20      | AVG      |
| 9   | 2.5900          | 10.19       | 26.66          | 36.85        | 56.00        | -19.15      | QP       |
| 10  | 2.5900          | 10.19       | 19.90          | 30.09        | 46.00        | -15.91      | AVG      |
| 11  | 3.1180          | 10.20       | 27.34          | 37.54        | 56.00        | -18.46      | QP       |
| 12  | 3.1180          | 10.20       | 18.30          | 28.50        | 46.00        | -17.50      | AVG      |

Note: Measurement Level = Reading Level + Correct Factor



|                  |  |            |            |
|------------------|--|------------|------------|
| Test Mode :      | Mode 8: Full system (DISPLAY mode 2560*1440@60Hz) Signal from PC (230V/50Hz) |            |            |
| AC Power :       | AC 230V/50Hz   | Phase :    | LINE       |
| Equipment :      | LCD Monitor  | Model No : | 238LM00023 |
| Temperature :    | 23°C   | Humidity : | 54%        |
| Pressure(mbar) : | 1001   | Date:      | 2017/03/21 |

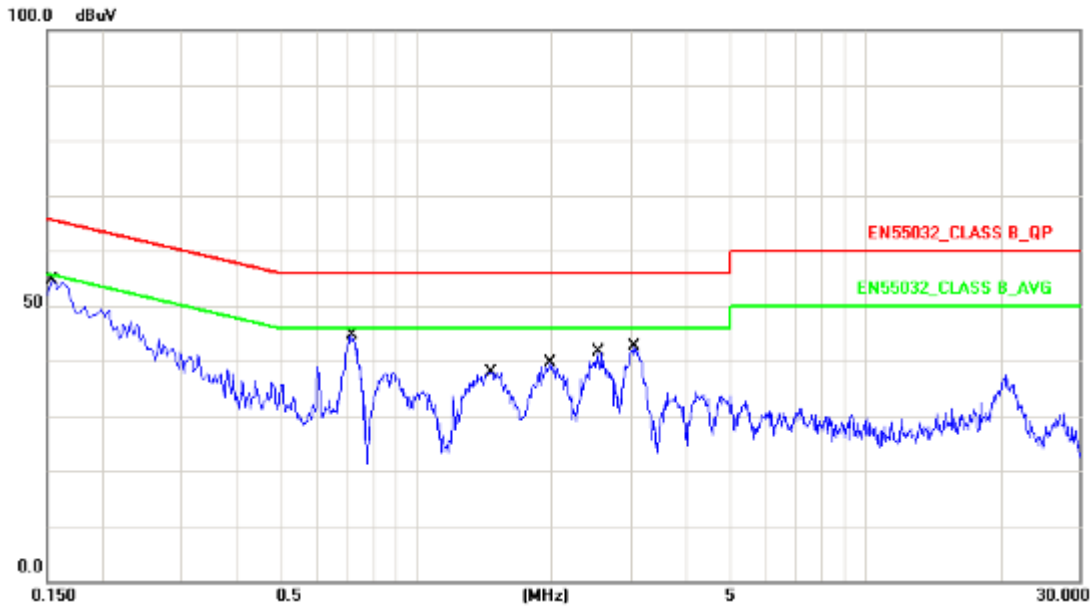

| No. | Frequency (MHz) | Factor (dB) | Reading (dBuV) | Level (dBuV) | Limit (dBuV) | Margin (dB) | Detector |
|-----|-----------------|-------------|----------------|--------------|--------------|-------------|----------|
| 1   | 0.1539          | 10.13       | 40.75          | 50.88        | 65.78        | -14.90      | QP       |
| 2   | 0.1539          | 10.13       | 28.99          | 39.12        | 55.78        | -16.66      | AVG      |
| 3   | 0.7180          | 10.15       | 31.75          | 41.90        | 56.00        | -14.10      | QP       |
| 4   | 0.7180          | 10.15       | 24.72          | 34.87        | 46.00        | -11.13      | AVG      |
| 5   | 1.4700          | 10.16       | 24.17          | 34.33        | 56.00        | -21.67      | QP       |
| 6   | 1.4700          | 10.16       | 18.79          | 28.95        | 46.00        | -17.05      | AVG      |
| 7   | 1.9820          | 10.17       | 25.28          | 35.45        | 56.00        | -20.55      | QP       |
| 8   | 1.9820          | 10.17       | 19.79          | 29.96        | 46.00        | -16.04      | AVG      |
| 9   | 2.5500          | 10.18       | 25.80          | 35.98        | 56.00        | -20.02      | QP       |
| 10  | 2.5500          | 10.18       | 19.04          | 29.22        | 46.00        | -16.78      | AVG      |
| 11  | 3.0620          | 10.19       | 27.64          | 37.83        | 56.00        | -18.17      | QP       |
| 12  | 3.0620          | 10.19       | 18.22          | 28.41        | 46.00        | -17.59      | AVG      |

Note: Measurement Level = Reading Level + Correct Factor





|                  |  |            |            |
|------------------|--|------------|------------|
| Test Mode :      | Mode 8: Full system (DISPLAY mode 2560*1440@60Hz) Signal from PC (230V/50Hz) |            |            |
| AC Power :       | AC 230V/50Hz   | Phase :    | NEUTRAL    |
| Equipment :      | LCD Monitor  | Model No : | 238LM00023 |
| Temperature :    | 23°C   | Humidity : | 54%        |
| Pressure(mbar) : | 1001   | Date:      | 2017/03/21 |

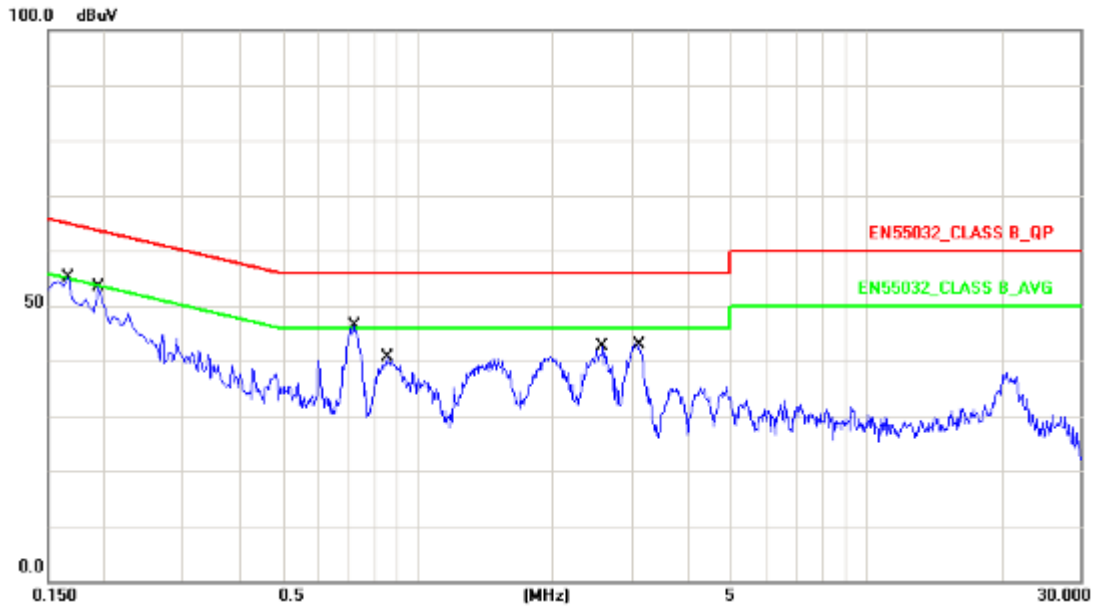

| No. | Frequency (MHz) | Factor (dB) | Reading (dBuV) | Level (dBuV) | Limit (dBuV) | Margin (dB) | Detector |
|-----|-----------------|-------------|----------------|--------------|--------------|-------------|----------|
| 1   | 0.1660          | 10.13       | 38.34          | 48.47        | 65.15        | -16.68      | QP       |
| 2   | 0.1660          | 10.13       | 25.57          | 35.70        | 55.15        | -19.45      | AVG      |
| 3   | 0.1940          | 10.13       | 36.43          | 46.56        | 63.86        | -17.30      | QP       |
| 4   | 0.1940          | 10.13       | 25.02          | 35.15        | 53.86        | -18.71      | AVG      |
| 5   | 0.7260          | 10.16       | 32.74          | 42.90        | 56.00        | -13.10      | QP       |
| 6   | 0.7260          | 10.16       | 26.37          | 36.53        | 46.00        | -9.47       | AVG      |
| 7   | 0.8540          | 10.17       | 26.95          | 37.12        | 56.00        | -18.88      | QP       |
| 8   | 0.8540          | 10.17       | 20.63          | 30.80        | 46.00        | -15.20      | AVG      |
| 9   | 2.5900          | 10.19       | 26.66          | 36.85        | 56.00        | -19.15      | QP       |
| 10  | 2.5900          | 10.19       | 19.90          | 30.09        | 46.00        | -15.91      | AVG      |
| 11  | 3.1180          | 10.20       | 27.34          | 37.54        | 56.00        | -18.46      | QP       |
| 12  | 3.1180          | 10.20       | 18.30          | 28.50        | 46.00        | -17.50      | AVG      |

Note: Measurement Level = Reading Level + Correct Factor



|                  |  |            |            |
|------------------|--|------------|------------|
| Test Mode :      | Mode 11: Full system (HDMI mode 2560*1440@60Hz) Signal from PC (110V/60Hz) |            |            |
| AC Power :       | AC 110V/60Hz   | Phase :    | LINE       |
| Equipment :      | LCD Monitor  | Model No : | 238LM00023 |
| Temperature :    | 23°C   | Humidity : | 54%        |
| Pressure(mbar) : | 1001   | Date:      | 2017/03/21 |

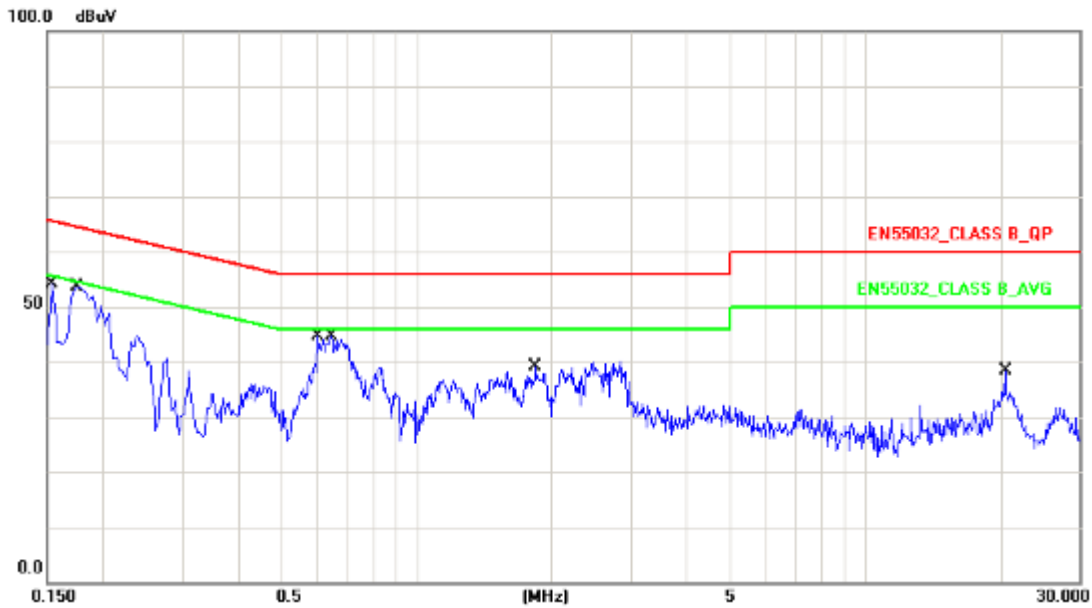

| No. | Frequency (MHz) | Factor (dB) | Reading (dBuV) | Level (dBuV) | Limit (dBuV) | Margin (dB) | Detector |
|-----|-----------------|-------------|----------------|--------------|--------------|-------------|----------|
| 1   | 0.1539          | 10.13       | 33.17          | 43.30        | 65.78        | -22.48      | QP       |
| 2   | 0.1539          | 10.13       | 10.85          | 20.98        | 55.78        | -34.80      | AVG      |
| 3   | 0.1740          | 10.13       | 39.85          | 49.98        | 64.76        | -14.78      | QP       |
| 4   | 0.1740          | 10.13       | 24.23          | 34.36        | 54.76        | -20.40      | AVG      |
| 5   | 0.6020          | 10.15       | 29.78          | 39.93        | 56.00        | -16.07      | QP       |
| 6   | 0.6020          | 10.15       | 26.01          | 36.16        | 46.00        | -9.84       | AVG      |
| 7   | 0.6460          | 10.15       | 32.01          | 42.16        | 56.00        | -13.84      | QP       |
| 8   | 0.6460          | 10.15       | 22.35          | 32.50        | 46.00        | -13.50      | AVG      |
| 9   | 1.8420          | 10.17       | 24.16          | 34.33        | 56.00        | -21.67      | QP       |
| 10  | 1.8420          | 10.17       | 17.02          | 27.19        | 46.00        | -18.81      | AVG      |
| 11  | 20.5140         | 10.36       | 25.00          | 35.36        | 60.00        | -24.64      | QP       |
| 12  | 20.5140         | 10.36       | 20.44          | 30.80        | 50.00        | -19.20      | AVG      |

Note: Measurement Level = Reading Level + Correct Factor



|                  |  |            |            |
|------------------|--|------------|------------|
| Test Mode :      | Mode 11: Full system (HDMI mode 2560*1440@60Hz) Signal from PC (110V/60Hz) |            |            |
| AC Power :       | AC 110V/60Hz   | Phase :    | NEUTRAL    |
| Equipment :      | LCD Monitor  | Model No : | 238LM00023 |
| Temperature :    | 23°C   | Humidity : | 54%        |
| Pressure(mbar) : | 1001   | Date:      | 2017/03/21 |

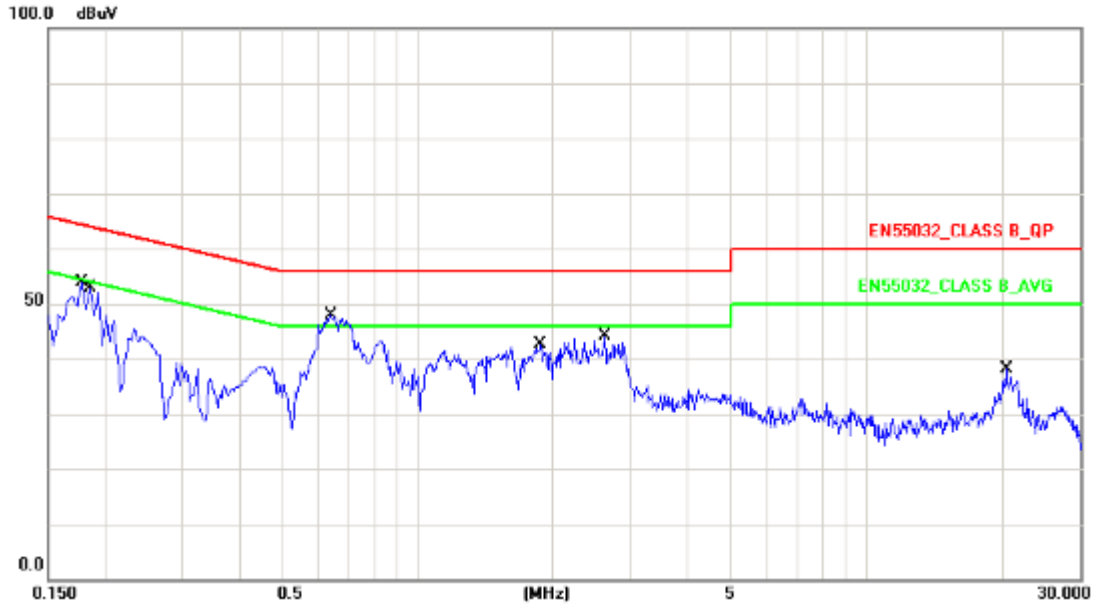

| No. | Frequency (MHz) | Factor (dB) | Reading (dBuV) | Level (dBuV) | Limit (dBuV) | Margin (dB) | Detector |
|-----|-----------------|-------------|----------------|--------------|--------------|-------------|----------|
| 1   | 0.1780          | 10.13       | 40.04          | 50.17        | 64.57        | -14.40      | QP       |
| 2   | 0.1780          | 10.13       | 27.22          | 37.35        | 54.57        | -17.22      | AVG      |
| 3   | 0.1860          | 10.13       | 39.87          | 50.00        | 64.21        | -14.21      | QP       |
| 4   | 0.1860          | 10.13       | 27.58          | 37.71        | 54.21        | -16.50      | AVG      |
| 5   | 0.6419          | 10.16       | 35.11          | 45.27        | 56.00        | -10.73      | QP       |
| 6   | 0.6419          | 10.16       | 25.49          | 35.65        | 46.00        | -10.35      | AVG      |
| 7   | 1.8780          | 10.18       | 26.16          | 36.34        | 56.00        | -19.66      | QP       |
| 8   | 1.8780          | 10.18       | 18.99          | 29.17        | 46.00        | -16.83      | AVG      |
| 9   | 2.6099          | 10.19       | 23.95          | 34.14        | 56.00        | -21.86      | QP       |
| 10  | 2.6099          | 10.19       | 15.33          | 25.52        | 46.00        | -20.48      | AVG      |
| 11  | 20.5140         | 10.44       | 25.59          | 36.03        | 60.00        | -23.97      | QP       |
| 12  | 20.5140         | 10.44       | 20.98          | 31.42        | 50.00        | -18.58      | AVG      |

Note: Measurement Level = Reading Level + Correct Factor



|                  |   |            |            |
|------------------|---|------------|------------|
| Test Mode :      | Mode 12: Full system (VGA mode 1920*1080@60Hz) Signal from PC (110V/60Hz) |            |            |
| AC Power :       | AC 110V/60Hz  | Phase :    | LINE       |
| Equipment :      | LCD Monitor   | Model No : | 238LM00023 |
| Temperature :    | 23°C  | Humidity : | 54%        |
| Pressure(mbar) : | 1001  | Date:      | 2017/03/21 |

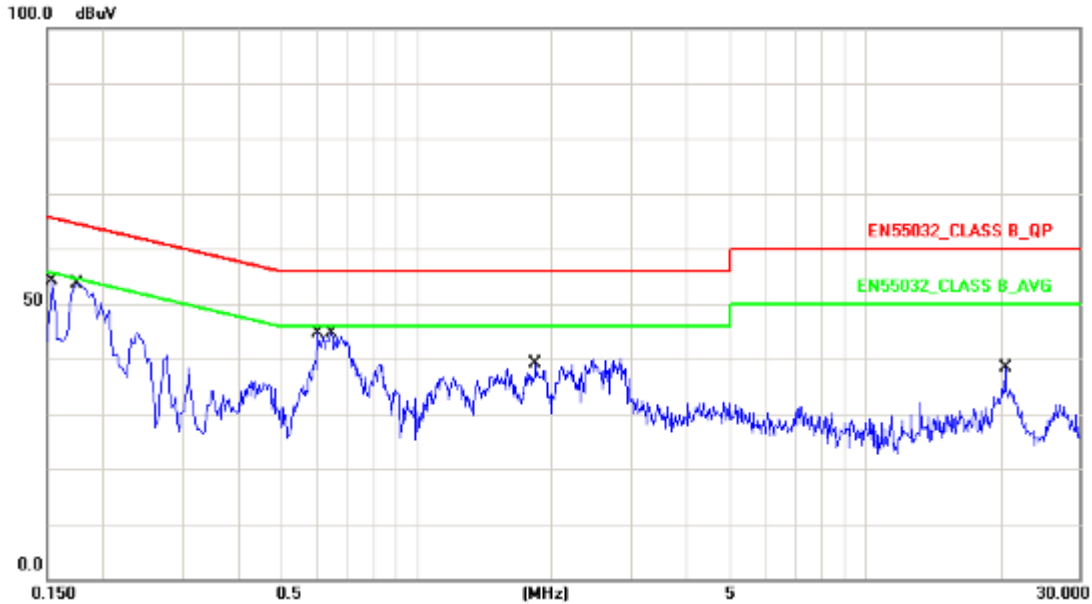

| No. | Frequency (MHz) | Factor (dB) | Reading (dBuV) | Level (dBuV) | Limit (dBuV) | Margin (dB) | Detector |
|-----|-----------------|-------------|----------------|--------------|--------------|-------------|----------|
| 1   | 0.1539          | 10.13       | 33.17          | 43.30        | 65.78        | -22.48      | QP       |
| 2   | 0.1539          | 10.13       | 10.85          | 20.98        | 55.78        | -34.80      | AVG      |
| 3   | 0.1740          | 10.13       | 39.85          | 49.98        | 64.76        | -14.78      | QP       |
| 4   | 0.1740          | 10.13       | 24.23          | 34.36        | 54.76        | -20.40      | AVG      |
| 5   | 0.6020          | 10.15       | 29.78          | 39.93        | 56.00        | -16.07      | QP       |
| 6   | 0.6020          | 10.15       | 26.01          | 36.16        | 46.00        | -9.84       | AVG      |
| 7   | 0.6460          | 10.15       | 32.01          | 42.16        | 56.00        | -13.84      | QP       |
| 8   | 0.6460          | 10.15       | 22.35          | 32.50        | 46.00        | -13.50      | AVG      |
| 9   | 1.8420          | 10.17       | 24.16          | 34.33        | 56.00        | -21.67      | QP       |
| 10  | 1.8420          | 10.17       | 17.02          | 27.19        | 46.00        | -18.81      | AVG      |
| 11  | 20.5140         | 10.36       | 25.00          | 35.36        | 60.00        | -24.64      | QP       |
| 12  | 20.5140         | 10.36       | 20.44          | 30.80        | 50.00        | -19.20      | AVG      |

Note: Measurement Level = Reading Level + Correct Factor



|                  |   |            |            |
|------------------|---|------------|------------|
| Test Mode :      | Mode 12: Full system (VGA mode 1920*1080@60Hz) Signal from PC (110V/60Hz) |            |            |
| AC Power :       | AC 110V/60Hz  | Phase :    | NEUTRAL    |
| Equipment :      | LCD Monitor   | Model No : | 238LM00023 |
| Temperature :    | 23°C  | Humidity : | 54%        |
| Pressure(mbar) : | 1001  | Date:      | 2017/03/21 |

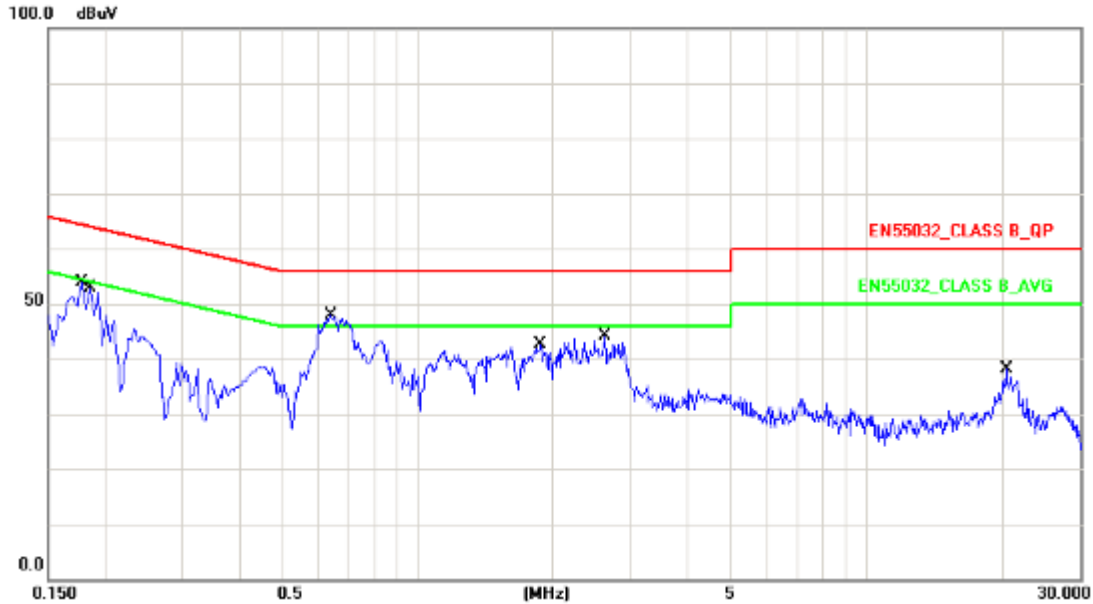

| No. | Frequency (MHz) | Factor (dB) | Reading (dBuV) | Level (dBuV) | Limit (dBuV) | Margin (dB) | Detector |
|-----|-----------------|-------------|----------------|--------------|--------------|-------------|----------|
| 1   | 0.1780          | 10.13       | 40.04          | 50.17        | 64.57        | -14.40      | QP       |
| 2   | 0.1780          | 10.13       | 27.22          | 37.35        | 54.57        | -17.22      | AVG      |
| 3   | 0.1860          | 10.13       | 39.87          | 50.00        | 64.21        | -14.21      | QP       |
| 4   | 0.1860          | 10.13       | 27.58          | 37.71        | 54.21        | -16.50      | AVG      |
| 5   | 0.6419          | 10.16       | 35.11          | 45.27        | 56.00        | -10.73      | QP       |
| 6   | 0.6419          | 10.16       | 25.49          | 35.65        | 46.00        | -10.35      | AVG      |
| 7   | 1.8780          | 10.18       | 26.16          | 36.34        | 56.00        | -19.66      | QP       |
| 8   | 1.8780          | 10.18       | 18.99          | 29.17        | 46.00        | -16.83      | AVG      |
| 9   | 2.6099          | 10.19       | 23.95          | 34.14        | 56.00        | -21.86      | QP       |
| 10  | 2.6099          | 10.19       | 15.33          | 25.52        | 46.00        | -20.48      | AVG      |
| 11  | 20.5140         | 10.44       | 25.59          | 36.03        | 60.00        | -23.97      | QP       |
| 12  | 20.5140         | 10.44       | 20.98          | 31.42        | 50.00        | -18.58      | AVG      |

Note: Measurement Level = Reading Level + Correct Factor



|                  |   |            |            |
|------------------|---|------------|------------|
| Test Mode :      | Mode 13: Full system (DISPLAY mode 2560*1440@60Hz) Signal from PC (110V/60Hz) |            |            |
| AC Power :       | AC 110V/60Hz  | Phase :    | LINE       |
| Equipment :      | LCD Monitor   | Model No : | 238LM00023 |
| Temperature :    | 23°C  | Humidity : | 54%        |
| Pressure(mbar) : | 1001  | Date:      | 2017/03/21 |

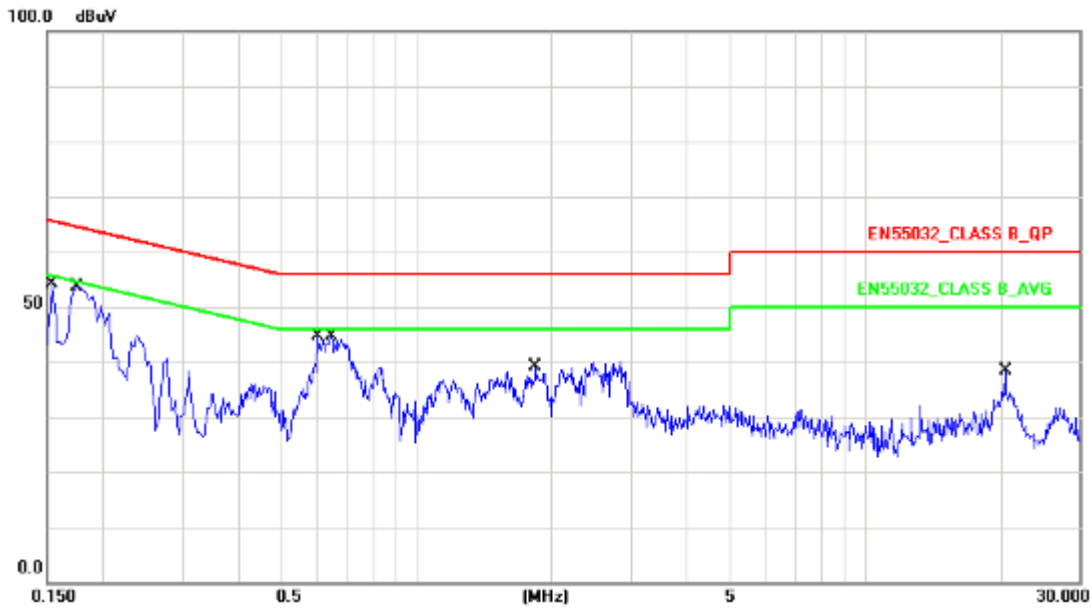

| No. | Frequency (MHz) | Factor (dB) | Reading (dBuV) | Level (dBuV) | Limit (dBuV) | Margin (dB) | Detector |
|-----|-----------------|-------------|----------------|--------------|--------------|-------------|----------|
| 1   | 0.1539          | 10.13       | 33.17          | 43.30        | 65.78        | -22.48      | QP       |
| 2   | 0.1539          | 10.13       | 10.85          | 20.98        | 55.78        | -34.80      | AVG      |
| 3   | 0.1740          | 10.13       | 39.85          | 49.98        | 64.76        | -14.78      | QP       |
| 4   | 0.1740          | 10.13       | 24.23          | 34.36        | 54.76        | -20.40      | AVG      |
| 5   | 0.6020          | 10.15       | 29.78          | 39.93        | 56.00        | -16.07      | QP       |
| 6   | 0.6020          | 10.15       | 26.01          | 36.16        | 46.00        | -9.84       | AVG      |
| 7   | 0.6460          | 10.15       | 32.01          | 42.16        | 56.00        | -13.84      | QP       |
| 8   | 0.6460          | 10.15       | 22.35          | 32.50        | 46.00        | -13.50      | AVG      |
| 9   | 1.8420          | 10.17       | 24.16          | 34.33        | 56.00        | -21.67      | QP       |
| 10  | 1.8420          | 10.17       | 17.02          | 27.19        | 46.00        | -18.81      | AVG      |
| 11  | 20.5140         | 10.36       | 25.00          | 35.36        | 60.00        | -24.64      | QP       |
| 12  | 20.5140         | 10.36       | 20.44          | 30.80        | 50.00        | -19.20      | AVG      |

Note: Measurement Level = Reading Level + Correct Factor



|                  |   |            |            |
|------------------|---|------------|------------|
| Test Mode :      | Mode 13: Full system (DISPLAY mode 2560*1440@60Hz) Signal from PC (110V/60Hz) |            |            |
| AC Power :       | AC 110V/60Hz  | Phase :    | NEUTRAL    |
| Equipment :      | LCD Monitor   | Model No : | 238LM00023 |
| Temperature :    | 23°C  | Humidity : | 54%        |
| Pressure(mbar) : | 1001  | Date:      | 2017/03/21 |

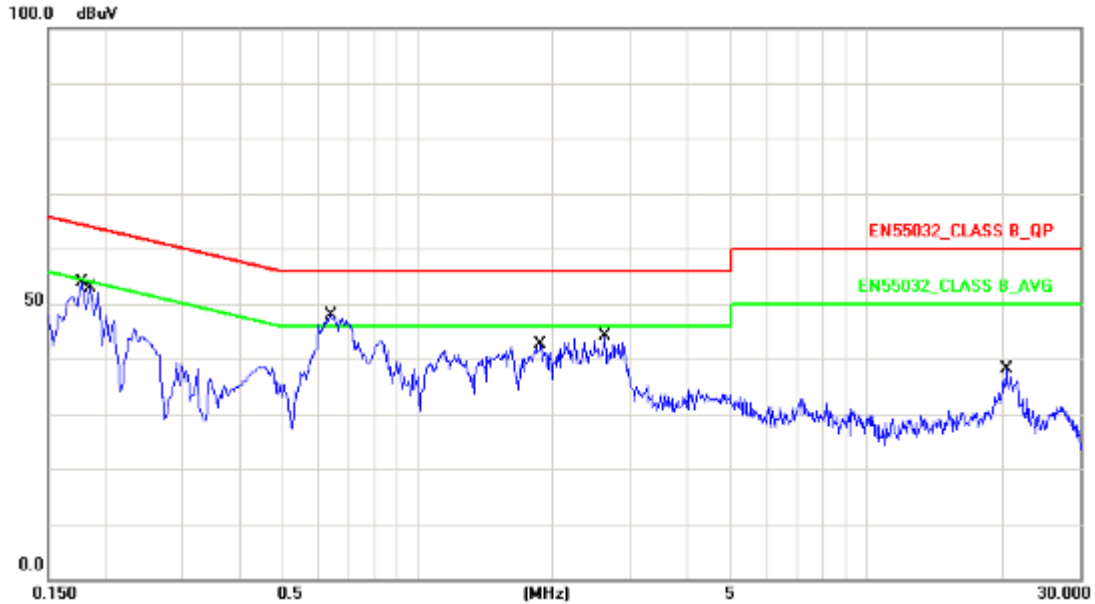

| No. | Frequency (MHz) | Factor (dB) | Reading (dBuV) | Level (dBuV) | Limit (dBuV) | Margin (dB) | Detector |
|-----|-----------------|-------------|----------------|--------------|--------------|-------------|----------|
| 1   | 0.1780          | 10.13       | 40.04          | 50.17        | 64.57        | -14.40      | QP       |
| 2   | 0.1780          | 10.13       | 27.22          | 37.35        | 54.57        | -17.22      | AVG      |
| 3   | 0.1860          | 10.13       | 39.87          | 50.00        | 64.21        | -14.21      | QP       |
| 4   | 0.1860          | 10.13       | 27.58          | 37.71        | 54.21        | -16.50      | AVG      |
| 5   | 0.6419          | 10.16       | 35.11          | 45.27        | 56.00        | -10.73      | QP       |
| 6   | 0.6419          | 10.16       | 25.49          | 35.65        | 46.00        | -10.35      | AVG      |
| 7   | 1.8780          | 10.18       | 26.16          | 36.34        | 56.00        | -19.66      | QP       |
| 8   | 1.8780          | 10.18       | 18.99          | 29.17        | 46.00        | -16.83      | AVG      |
| 9   | 2.6099          | 10.19       | 23.95          | 34.14        | 56.00        | -21.86      | QP       |
| 10  | 2.6099          | 10.19       | 15.33          | 25.52        | 46.00        | -20.48      | AVG      |
| 11  | 20.5140         | 10.44       | 25.59          | 36.03        | 60.00        | -23.97      | QP       |
| 12  | 20.5140         | 10.44       | 20.98          | 31.42        | 50.00        | -18.58      | AVG      |

Note: Measurement Level = Reading Level + Correct Factor

Test engineer: Sun. Zhang



#### 4.5.2 Conducted Emission for Telecommunication Port Test Data

Note: The EUT doesn't have the telecommunication port.





#### 4.6. Test Photographs of Power Port

Front View



Rear View





## 5. Test of Radiated Emission

### 5.1. Test Limit

The EUT shall meet the limits of below Table when measured at the measuring distance R in accordance with the methods described in European Standard EN 55032. If the reading on the measuring receiver shows fluctuations close to the limit, the reading shall be observed for at least 15 s at each measurement frequency; the highest reading shall be recorded, with the exception of any brief isolated high reading, which shall be ignored.

**Table 1 – Required highest frequency for radiated measurement**

| Highest internal frequency<br>( $F_x$ ) | Highest measured frequency              |
|---|---|
| $F_x \leq 108$ MHz                      | 1 GHz                                   |
| $108$ MHz $< F_x \leq 500$ MHz          | 2 GHz                                   |
| $500$ MHz $< F_x \leq 1$ GHz            | 5 GHz                                   |
| $F_x > 1$ GHz                           | $5 \times F_x$ up to a maximum of 6 GHz |

NOTE 1 For FM and TV broadcast receivers,  $F_x$  is determined from the highest frequency generated or used excluding the local oscillator and tuned frequencies.

NOTE 2  $F_x$  is defined in 3.1.19.

Where the  $F_x$  is unknown, the radiated emission measurements shall be performed up to 6 GHz.

**Table A.2 – Requirements for radiated emissions at frequencies up to 1 GHz for Class A equipment**

| Table clause | Frequency range<br>MHz | Measurement   |                             | Class A limits dB( $\mu$ V/m) |
|--------------|------------------------|---------------|-----------------------------|-------------------------------|
|              |                        | Distance<br>m | Detector type/<br>bandwidth | OATS/SAC<br>(see Table A.1)   |
| A2.1         | 30 – 230               | 10            | Quasi Peak /<br>120 kHz     | 40                            |
|              | 230 – 1 000            |               |                             | 47                            |
| A2.2         | 30 – 230               | 3             |                             | 50                            |
|              | 230 – 1 000            |               |                             | 57                            |

NOTE Apply only A2.1 or A2.2 across the entire frequency range.

**Table A.3 – Requirements for radiated emissions at frequencies above 1 GHz for Class A equipment**

| Table clause | Frequency range<br>MHz | Measurement   |                             | Class A limits dB( $\mu$ V/m) |
|--------------|------------------------|---------------|-----------------------------|-------------------------------|
|              |                        | Distance<br>m | Detector type/<br>bandwidth | FSOATS<br>(see Table A.1)     |
| A3.1         | 1 000 – 3 000          | 3             | Average /<br>1 MHz          | 56                            |
|              | 3 000 – 6 000          |               |                             | 60                            |
| A3.2         | 1 000 – 3 000          |               | Peak /<br>1 MHz             | 76                            |
|              | 3 000 – 6 000          |               |                             | 80                            |

NOTE Apply A3.1 and A3.2 across the frequency range from 1 000 MHz to the highest required frequency of measurement derived from Table 1.



**Table A.4 – Requirements for radiated emissions at frequencies up to 1 GHz for Class B equipment**

| Table clause | Frequency range<br>MHz | Measurement   |                             | Class B limits dB(μV/m)     |  |
|--------------|------------------------|---------------|-----------------------------|-----------------------------|--|
|              |                        | Distance<br>m | Detector type/<br>bandwidth | OATS/SAC<br>(see Table A.1) |  |
| A4.1         | 30 – 230               | 10            | Quasi Peak /<br>120 kHz     | 30                          |  |
|              | 230 – 1 000            |               |                             | 37                          |  |
| A4.2         | 30 – 230               | 3             |                             | 40                          |  |
|              | 230 – 1 000            |               |                             | 47                          |  |

NOTE Apply only table clause A4.1 or A4.2 across the entire frequency range.

**Table A.5 – Requirements for radiated emissions at frequencies above 1 GHz for Class B equipment**

| Table clause | Frequency range<br>MHz | Measurement   |                             | Class B limits dB(μV/m)   |  |
|--------------|------------------------|---------------|-----------------------------|---------------------------|--|
|              |                        | Distance<br>m | Detector type/<br>bandwidth | FSOATS<br>(see Table A.1) |  |
| A5.1         | 1 000 – 3 000          | 3             | Average/<br>1 MHz           | 50                        |  |
|              | 3 000 – 6 000          |               |                             | 54                        |  |
| A5.2         | 1 000 – 3 000          |               | Peak/<br>1 MHz              | 70                        |  |
|              | 3 000 – 6 000          |               |                             | 74                        |  |

NOTE Apply A5.1 and A5.2 across the frequency range from 1 000 MHz to the highest required frequency of measurement derived from Table 1.

**Table A.6 – Requirements for radiated emissions from FM receivers**

| Table clause | Frequency range<br>MHz | Measurement   |                             | Class B limit dB(μV/m)      |                             |    |
|--------------|------------------------|---------------|-----------------------------|-----------------------------|-----------------------------|----|
|              |                        | Distance<br>m | Detector type/<br>bandwidth | Fundamental                 | Harmonics                   |    |
|              |                        |               |                             | OATS/SAC<br>(see Table A.1) | OATS/SAC<br>(see Table A.1) |    |
| A6.1         | 30 – 230               | 10            | Quasi peak/<br>120 kHz      | 50                          | 42                          |    |
|              | 230 – 300              |               |                             |                             | 42                          |    |
|              | 300 – 1 000            |               |                             |                             | 46                          |    |
| A6.2         | 30 – 230               | 3             |                             | Quasi peak/<br>120 kHz      | 60                          | 52 |
|              | 230 – 300              |               |                             |                             |                             | 52 |
|              | 300 – 1 000            |               |                             |                             |                             | 56 |

NOTE 1 Apply only A.6.1 or A.6.2 across the entire frequency range.

NOTE 2 These relaxed limits apply only to emissions at the fundamental and harmonic frequencies of the local oscillator. Signals at all other frequencies shall be compliant with the limits given in Table A.4.



**Table A.12 – Requirements for conducted differential voltage emissions from Class B equipment**

| <b>Applicable to</b>  |                     |                          |                            |                              |                            |               |
|---|---------------------|--------------------------|----------------------------|------------------------------|----------------------------|---------------|
| 1. TV broadcast receiver tuner ports (3.1.8) with an accessible connector |                     |                          |                            |                              |                            |               |
| 2. RF modulator output ports (3.1.27)                                     |                     |                          |                            |                              |                            |               |
| 3. FM broadcast receiver tuner ports (3.1.8) with an accessible connector |                     |                          |                            |                              |                            |               |
| Table clause  | Frequency range MHz | Detector type/ bandwidth | Class B limits dB(μV) 75 Ω |                              |                            | Applicability |
|   |                     |                          | Other                      | Local Oscillator Fundamental | Local Oscillator Harmonics |               |
| A12.1   | 30 – 950            | For frequencies ≤1 GHz   | 46                         | 46                           | 46                         | See NOTE 1    |
|   | 950 – 2 150         |                          | 46                         | 54                           | 54                         |               |
| A12.2   | 950 – 2 150         |                          | 46                         | 54                           | 54                         | See NOTE 2    |
| A12.3   | 30 – 300            |                          | Quasi Peak/ 120 kHz        | 46                           | 54                         | 50            |
|   | 300 – 1 000         | 52                       |                            |                              |                            |               |
| A12.4   | 30 – 300            | For frequencies ≥1 GHz   | 46                         | 66                           | 59                         | See NOTE 4    |
|   | 300 – 1 000         |                          |                            |                              | 52                         |               |
| A12.5   | 30 – 950            | Peak/ 1 MHz              | 46                         | 76                           | 46                         | See NOTE 5    |
|   | 950 – 2 150         |                          |                            | n/a                          | 54                         |               |

NOTE 1 Television receivers (analogue or digital), video recorders and PC TV broadcast receiver tuner cards working in channels between 30 MHz and 1 GHz, and digital audio receivers.

NOTE 2 Tuner units (not the LNB) for satellite signal reception.

NOTE 3 Frequency modulation audio receivers and PC tuner cards.

NOTE 4 Frequency modulation car radios.

NOTE 5 Applicable to EUTs with RF modulator output ports (for example DVD equipment, video recorders, camcorders and decoders etc.) designed to connect to TV broadcast receiver tuner ports.

NOTE 6 Testing is required at only one EUT supply voltage and frequency.

NOTE 7 The term 'other' refers to all emissions other than the fundamental and the harmonics of the local oscillator.

NOTE 8 The test shall be performed with the device operating at each reception channel.

NOTE 9 The test shall cover the entire frequency range.

## 5.2. Test Procedures

- a. The EUT was placed on a rotatable table top 0.8 meter above ground.
- b. The EUT was set 3/10 meters from the interference receiving antenna which was mounted on the top of a variable height antenna tower.
- c. The table was rotated 360 degrees to determine the position of the highest radiation.
- d. The antenna is a half wave dipole and its height is varied between one meter and four meters above ground to find the maximum value of the field strength both horizontal polarization and vertical polarization of the antenna are set to make the measurement.
- e. For each suspected emission the EUT was arranged to its worst case and then tune the antenna tower (from 1 M to 4 M) and turn table (from 0 degree to 360 degrees) to find the maximum reading.
- f. Set the test-receiver system to Peak Detect Function and specified bandwidth with Maximum Hold Mode.
- g. If the emission level of the EUT in peak mode was 3 dB lower than the limit specified, then testing will be stopped and peak values of EUT will be reported, otherwise, the emissions which do not have 3 dB margin will be repeated one by one using the quasi-peak method and reported.

## 5.3. Typical Test Setup

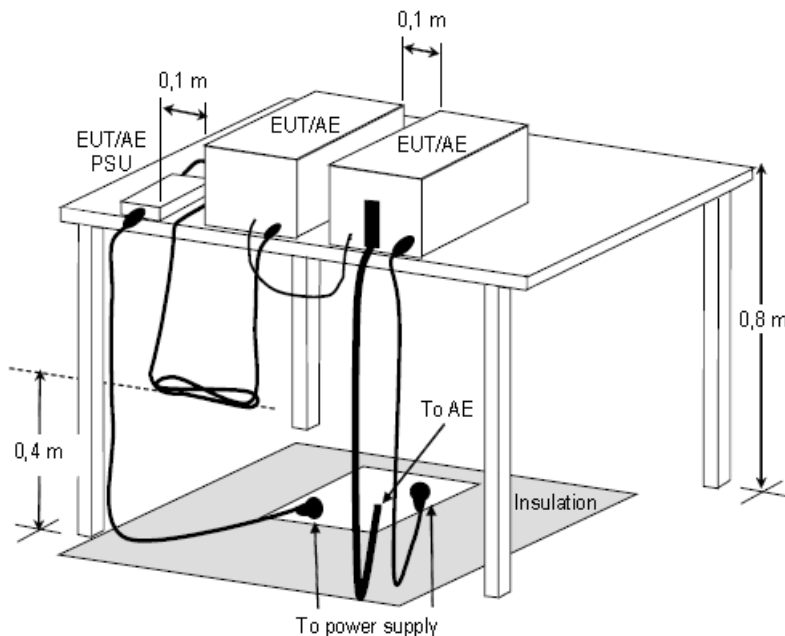

**Figure D.8 – Example measurement arrangement for table-top EUT (Radiated emission measurement)**



#### 5.4. Measurement Equipment

| Instrument/Ancillary        | Manufacturer  | Model No. | Serial No. | Calibration Date | Valid Date. |
|-----------------------------|---------------|-----------|------------|------------------|-------------|
| EMI Test Receiver           | R&S           | ESCI7     | 100968     | 2016.03.26       | 2017.03.25  |
| Preamplifier                | Agilent       | 87405B    | My39500554 | 2016.03.26       | 2017.03.25  |
| Preamplifier                | Agilent       | 8449B     | 3008A02342 | 2016.03.26       | 2017.03.25  |
| Bilog Antenna               | Sunol Science | JB1       | A072414-1  | 2016.04.16       | 2017.04.15  |
| Broad-Band Horn Antenna     | Schwarzbeck   | BBHA9120D | 9120D-618  | 2016.04.16       | 2017.04.15  |
| Spectrum Analyzer           | R&S           | FSP40     | 100324     | 2016.03.26       | 2017.03.25  |
| Temperature/ Humidity Meter | Zhicheng      | ZC1-11    | CEP-TH-001 | 2016.03.29       | 2017.03.28  |
| EZ-EMC                      | Fala          | Ver CT3A1 | N/A        | N/A              | N/A         |



5.5. Test Result and Data (30MHz ~ 1GHz)

|                  |   |                    |            |
|------------------|---|--------------------|------------|
| Test Mode :      | Mode 1: Full system (HDMI mode 2560*1440@60Hz) Signal from PC (230V/50Hz) |                    |            |
| AC Power :       | AC 230V/50Hz  | Ant. Polarization: | Horizontal |
| Equipment :      | LCD Monitor   | Model No :         | 238LM00023 |
| Temperature :    | 22°C  | Humidity :         | 53%        |
| Pressure(mbar) : | 1001  | Date:              | 2017/03/21 |

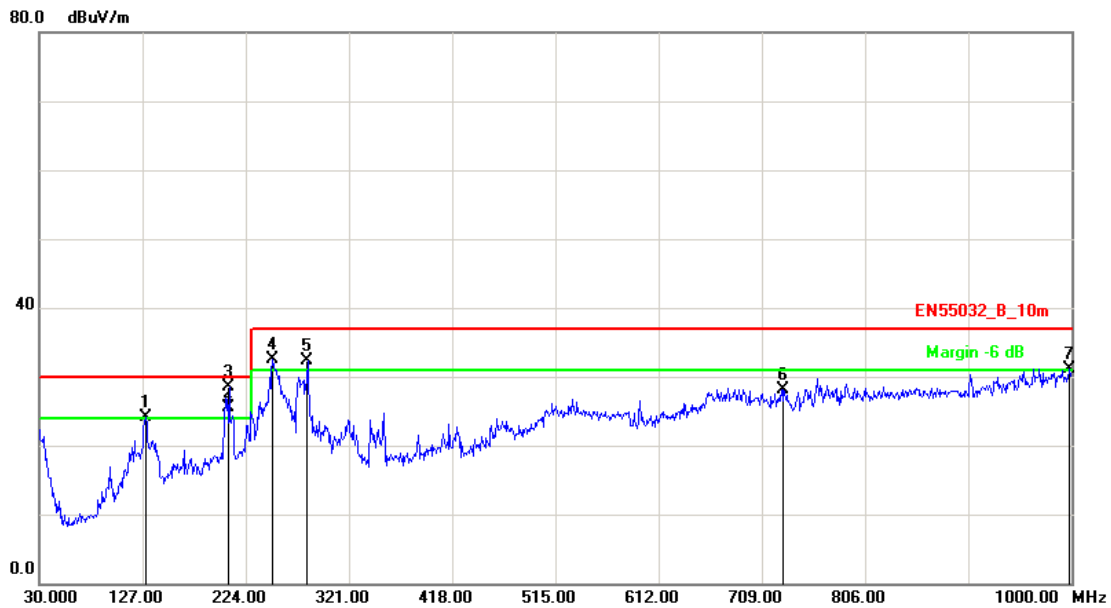

| No. | Frequency (MHz) | Factor (dB/m) | Reading (dBuV) | Level (dBuV/m) | Limit (dBuV/m) | Margin (dB) | Det. | Height (cm) | Azimuth (deg) |
|-----|-----------------|---------------|----------------|----------------|----------------|-------------|------|-------------|---------------|
| 1   | 129.9098        | -9.98         | 34.09          | 24.11          | 30.00          | -5.89       | peak | 100         | 15            |
| 2   | 207.9850        | -10.72        | 36.17          | 25.45          | 30.00          | -4.55       | QP   | 200         | 50            |
| 3   | 208.4798        | -10.77        | 39.29          | 28.52          | 30.00          | -1.48       | peak | 200         | 45            |
| 4   | 249.2199        | -10.48        | 43.01          | 32.53          | 37.00          | -4.47       | peak | 200         | 156           |
| 5   | 282.1999        | -8.82         | 41.11          | 32.29          | 37.00          | -4.71       | peak | 300         | 45            |
| 6   | 729.3700        | 0.58          | 27.58          | 28.16          | 37.00          | -8.84       | peak | 300         | 5             |
| 7   | 998.0599        | 4.69          | 26.51          | 31.20          | 37.00          | -5.80       | peak | 200         | 325           |

Note: Measurement Level = Reading Level + Correct Factor



|                  |   |                    |            |
|------------------|---|--------------------|------------|
| Test Mode :      | Mode 1: Full system (HDMI mode 2560*1440@60Hz) Signal from PC (230V/50Hz) |                    |            |
| AC Power :       | AC 230V/50Hz  | Ant. Polarization: | Vertical   |
| Equipment :      | LCD Monitor   | Model No :         | 238LM00023 |
| Temperature :    | 22°C  | Humidity :         | 53%        |
| Pressure(mbar) : | 1001  | Date:              | 2017/03/21 |

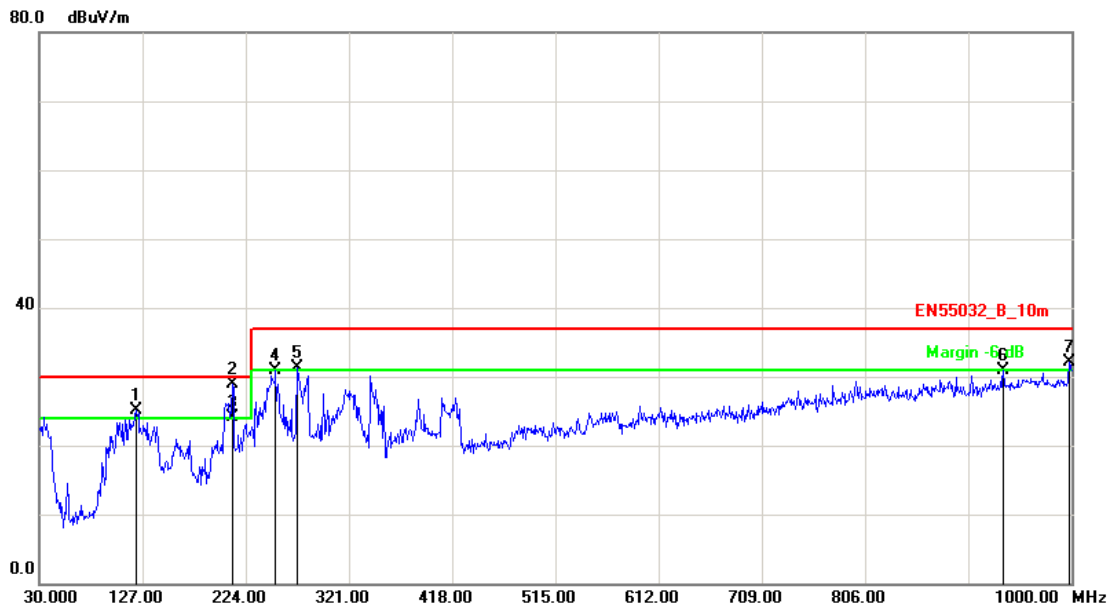

| No. | Frequency (MHz) | Factor (dB/m) | Reading (dBuV) | Level (dBuV/m) | Limit (dBuV/m) | Margin (dB) | Det. | Height (cm) | Azimuth (deg) |
|-----|-----------------|---------------|----------------|----------------|----------------|-------------|------|-------------|---------------|
| 1   | 121.1800        | -9.60         | 34.67          | 25.07          | 30.00          | -4.93       | peak | 200         | 36            |
| 2   | 211.3899        | -11.06        | 39.91          | 28.85          | 30.00          | -1.15       | peak | 100         | 54            |
| 3   | 211.5980        | -11.09        | 35.12          | 24.03          | 30.00          | -5.97       | QP   | 100         | 52            |
| 4   | 252.1299        | -10.36        | 41.20          | 30.84          | 37.00          | -6.16       | peak | 200         | 236           |
| 5   | 272.5000        | -9.28         | 40.55          | 31.27          | 37.00          | -5.73       | peak | 100         | 45            |
| 6   | 935.9800        | 3.87          | 27.05          | 30.92          | 37.00          | -6.08       | peak | 100         | 2             |
| 7   | 998.0599        | 4.69          | 27.45          | 32.14          | 37.00          | -4.86       | peak | 300         | 148           |

Note: Measurement Level = Reading Level + Correct Factor





|                  |  |                    |            |
|------------------|--|--------------------|------------|
| Test Mode :      | Mode 5: Full system (VGA mode 1920*1080@60Hz) Signal from PC (230V/50Hz) |                    |            |
| AC Power :       | AC 230V/50Hz   | Ant. Polarization: | Horizontal |
| Equipment :      | LCD Monitor  | Model No :         | 238LM00023 |
| Temperature :    | 22°C   | Humidity :         | 53%        |
| Pressure(mbar) : | 1001   | Date:              | 2017/03/21 |

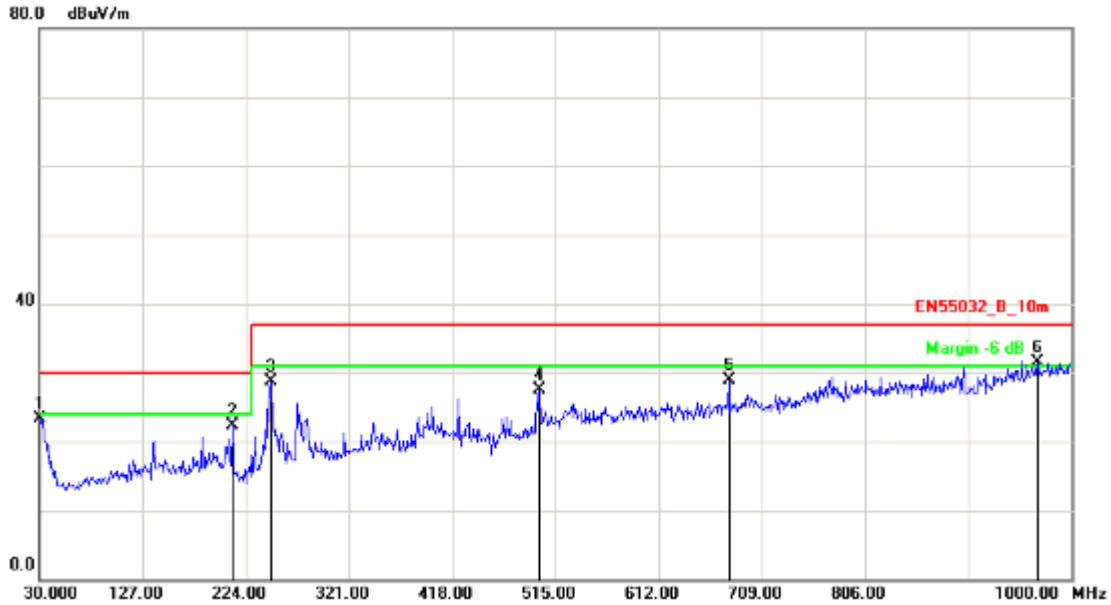

| No. | Frequency (MHz) | Factor (dB/m) | Reading (dBuV) | Level (dBuV/m) | Limit (dBuV/m) | Margin (dB) | Det. | Height (cm) | Azimuth (deg) |
|-----|-----------------|---------------|----------------|----------------|----------------|-------------|------|-------------|---------------|
| 1   | 30.0000         | -3.26         | 26.65          | 23.39          | 30.00          | -6.61       | peak | 100         | 2             |
| 2   | 211.3899        | -11.06        | 33.32          | 22.26          | 30.00          | -7.74       | peak | 300         | 145           |
| 3   | 247.2800        | -10.55        | 39.20          | 28.65          | 37.00          | -8.35       | peak | 200         | 69            |
| 4   | 500.4499        | -3.00         | 30.54          | 27.54          | 37.00          | -9.46       | peak | 100         | 25            |
| 5   | 677.9600        | -0.14         | 29.14          | 29.00          | 37.00          | -8.00       | peak | 100         | 26            |
| 6   | 967.9900        | 4.53          | 26.98          | 31.51          | 37.00          | -5.49       | peak | 200         | 236           |

Note: Measurement Level = Reading Level + Correct Factor



|                  |  |                    |            |
|------------------|--|--------------------|------------|
| Test Mode :      | Mode 5: Full system (VGA mode 1920*1080@60Hz) Signal from PC (230V/50Hz) |                    |            |
| AC Power :       | AC 230V/50Hz   | Ant. Polarization: | Vertical   |
| Equipment :      | LCD Monitor  | Model No :         | 238LM00023 |
| Temperature :    | 22°C   | Humidity :         | 53%        |
| Pressure(mbar) : | 1001   | Date:              | 2017/03/21 |

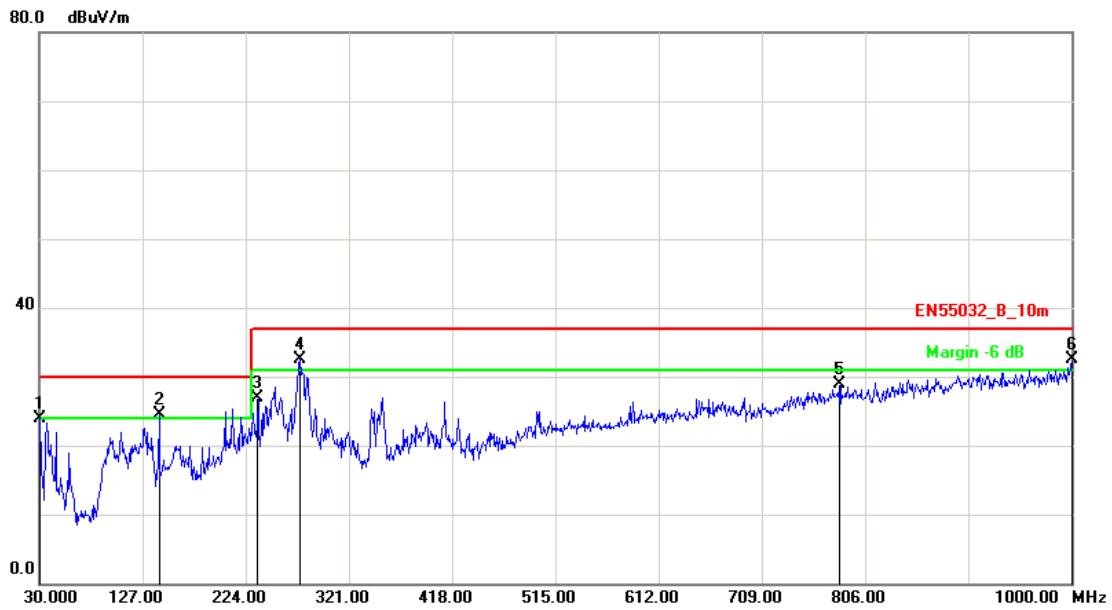

| No. | Frequency (MHz) | Factor (dB/m) | Reading (dBuV) | Level (dBuV/m) | Limit (dBuV/m) | Margin (dB) | Det. | Height (cm) | Azimuth (deg) |
|-----|-----------------|---------------|----------------|----------------|----------------|-------------|------|-------------|---------------|
| 1   | 30.0000         | -3.26         | 27.11          | 23.85          | 30.00          | -6.15       | peak | 200         | 55            |
| 2   | 142.5200        | -10.48        | 34.93          | 24.45          | 30.00          | -5.55       | peak | 100         | 2             |
| 3   | 235.6399        | -11.09        | 38.08          | 26.99          | 37.00          | -10.01      | peak | 300         | 45            |
| 4   | 275.4100        | -9.11         | 41.62          | 32.51          | 37.00          | -4.49       | peak | 400         | 219           |
| 5   | 782.7199        | 1.84          | 27.03          | 28.87          | 37.00          | -8.13       | peak | 100         | 58            |
| 6   | 1000.0000       | 4.68          | 27.82          | 32.50          | 37.00          | -4.50       | peak | 100         | 0             |

Note: Measurement Level = Reading Level + Correct Factor



|                  |  |                    |            |
|------------------|--|--------------------|------------|
| Test Mode :      | Mode 8: Full system (DISPLAY mode 2560*1440@60Hz) Signal from PC (230V/50Hz) |                    |            |
| AC Power :       | AC 230V/50Hz   | Ant. Polarization: | Horizontal |
| Equipment :      | LCD Monitor  | Model No :         | 238LM00023 |
| Temperature :    | 22°C   | Humidity :         | 53%        |
| Pressure(mbar) : | 1001   | Date:              | 2017/03/21 |

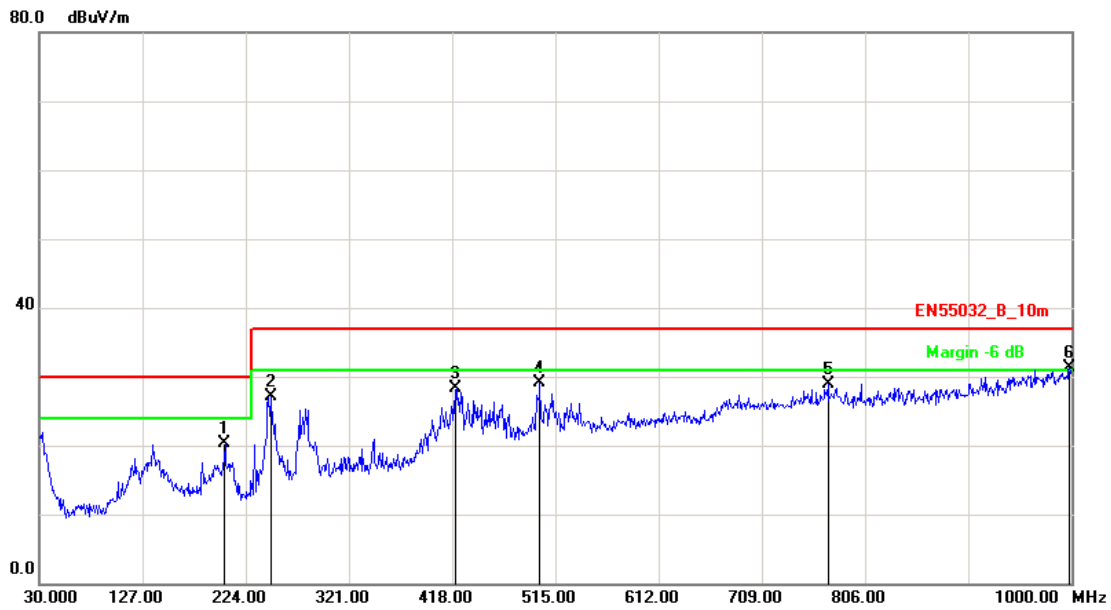

| No. | Frequency (MHz) | Factor (dB/m) | Reading (dBuV) | Level (dBuV/m) | Limit (dBuV/m) | Margin (dB) | Det. | Height (cm) | Azimuth (deg) |
|-----|-----------------|---------------|----------------|----------------|----------------|-------------|------|-------------|---------------|
| 1   | 204.5999        | -10.38        | 30.66          | 20.28          | 30.00          | -9.72       | peak | 100         | 269           |
| 2   | 247.2800        | -10.55        | 37.63          | 27.08          | 37.00          | -9.92       | peak | 100         | 360           |
| 3   | 421.8799        | -5.22         | 33.61          | 28.39          | 37.00          | -8.61       | peak | 200         | 25            |
| 4   | 500.4499        | -3.00         | 32.13          | 29.13          | 37.00          | -7.87       | peak | 200         | 43            |
| 5   | 771.0800        | 1.59          | 27.30          | 28.89          | 37.00          | -8.11       | peak | 100         | 1             |
| 6   | 998.0599        | 4.69          | 26.69          | 31.38          | 37.00          | -5.62       | peak | 300         | 35            |

Note: Measurement Level = Reading Level + Correct Factor



|                  |  |                    |            |
|------------------|--|--------------------|------------|
| Test Mode :      | Mode 8: Full system (DISPLAY mode 2560*1440@60Hz) Signal from PC (230V/50Hz) |                    |            |
| AC Power :       | AC 230V/50Hz   | Ant. Polarization: | Vertical   |
| Equipment :      | LCD Monitor  | Model No :         | 238LM00023 |
| Temperature :    | 22°C   | Humidity :         | 53%        |
| Pressure(mbar) : | 1001   | Date:              | 2017/03/21 |

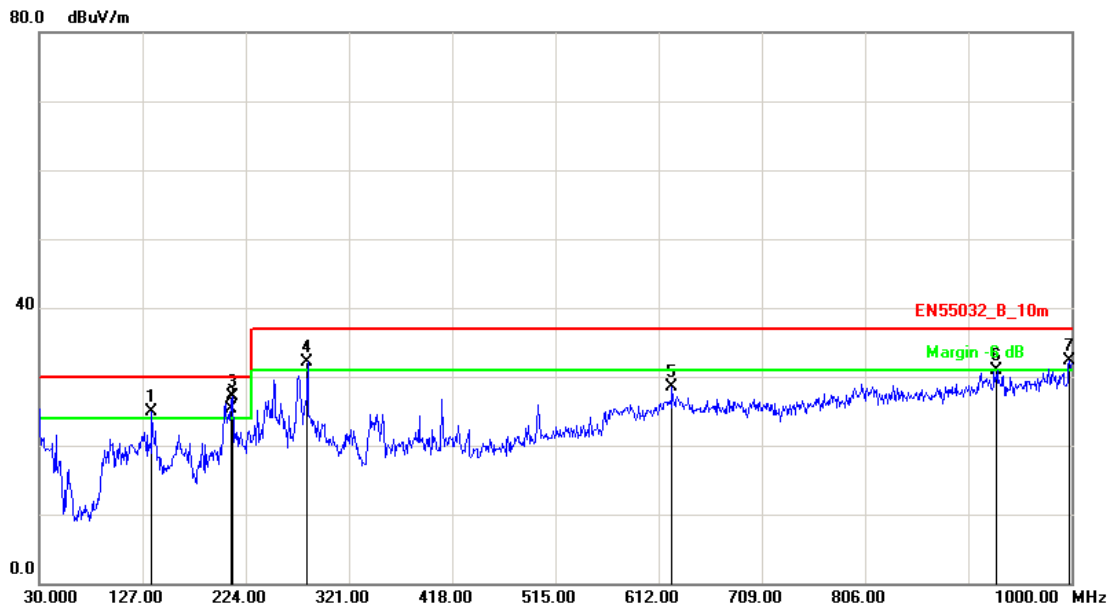

| No. | Frequency (MHz) | Factor (dB/m) | Reading (dBuV) | Level (dBuV/m) | Limit (dBuV/m) | Margin (dB) | Det. | Height (cm) | Azimuth (deg) |
|-----|-----------------|---------------|----------------|----------------|----------------|-------------|------|-------------|---------------|
| 1   | 135.7298        | -10.23        | 35.11          | 24.88          | 30.00          | -5.12       | peak | 200         | 25            |
| 2   | 211.0150        | -11.03        | 36.42          | 25.39          | 30.00          | -4.61       | QP   | 100         | 300           |
| 3   | 211.3899        | -11.06        | 38.09          | 27.03          | 30.00          | -2.97       | peak | 100         | 306           |
| 4   | 282.1999        | -8.82         | 40.85          | 32.03          | 37.00          | -4.97       | peak | 200         | 4             |
| 5   | 624.6100        | -0.87         | 29.37          | 28.50          | 37.00          | -8.50       | peak | 200         | 265           |
| 6   | 930.1598        | 3.81          | 27.14          | 30.95          | 37.00          | -6.05       | peak | 100         | 7             |
| 7   | 998.0599        | 4.69          | 27.55          | 32.24          | 37.00          | -4.76       | peak | 100         | 78            |

Note: Measurement Level = Reading Level + Correct Factor



|                  |  |                    |            |
|------------------|--|--------------------|------------|
| Test Mode :      | Mode 11: Full system (HDMI mode 2560*1440@60Hz) Signal from PC (110V/60Hz) |                    |            |
| AC Power :       | AC 110V/60Hz   | Ant. Polarization: | Horizontal |
| Equipment :      | LCD Monitor  | Model No :         | 238LM00023 |
| Temperature :    | 22°C   | Humidity :         | 53%        |
| Pressure(mbar) : | 1001   | Date:              | 2017/03/21 |

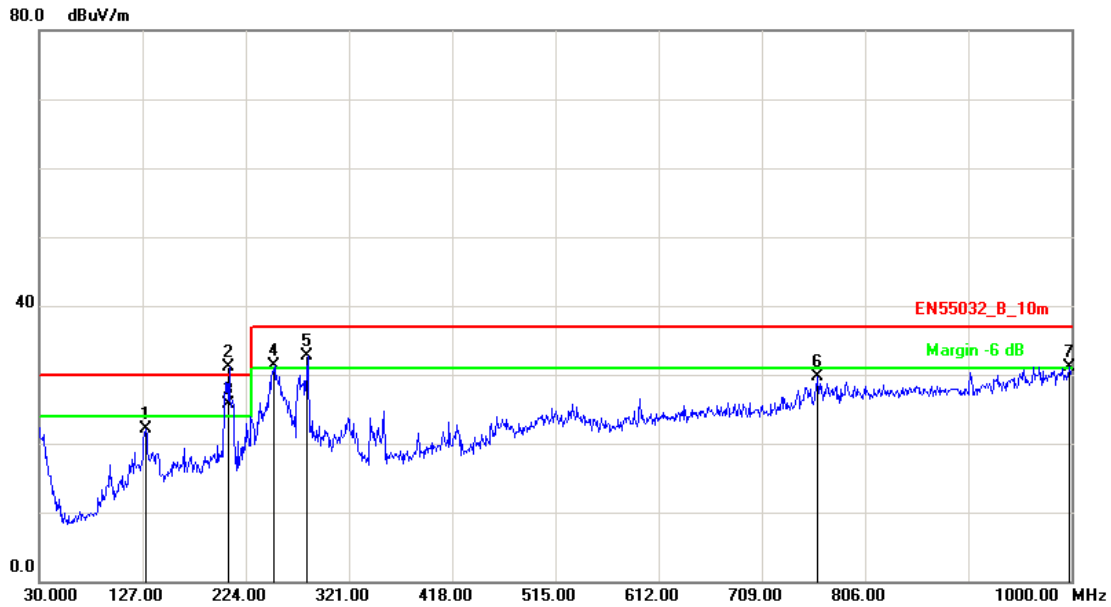

| No. | Frequency (MHz) | Factor (dB/m) | Reading (dBuV) | Level (dBuV/m) | Limit (dBuV/m) | Margin (dB) | Det. | Height (cm) | Azimuth (deg) |
|-----|-----------------|---------------|----------------|----------------|----------------|-------------|------|-------------|---------------|
| 1   | 129.9099        | -9.98         | 32.09          | 22.11          | 30.00          | -7.89       | peak | 400         | 1             |
| 2   | 208.4798        | -10.77        | 41.79          | 31.02          | 30.00          | 1.02        | peak | 400         | 353           |
| 3   | 208.4798        | -10.77        | 36.46          | 25.69          | 30.00          | -4.31       | QP   | 400         | 360           |
| 4   | 251.1599        | -10.40        | 41.72          | 31.32          | 37.00          | -5.68       | peak | 400         | 84            |
| 5   | 282.1999        | -8.82         | 41.61          | 32.79          | 37.00          | -4.21       | peak | 400         | 112           |
| 6   | 761.3799        | 1.36          | 28.30          | 29.66          | 37.00          | -7.34       | peak | 100         | 360           |
| 7   | 998.0599        | 4.69          | 26.51          | 31.20          | 37.00          | -5.80       | peak | 100         | 40            |

Note: Measurement Level = Reading Level + Correct Factor



|                  |  |                    |            |
|------------------|--|--------------------|------------|
| Test Mode :      | Mode 11: Full system (HDMI mode 2560*1440@60Hz) Signal from PC (110V/60Hz) |                    |            |
| AC Power :       | AC 110V/60Hz   | Ant. Polarization: | Vertical   |
| Equipment :      | LCD Monitor  | Model No :         | 238LM00023 |
| Temperature :    | 22°C   | Humidity :         | 53%        |
| Pressure(mbar) : | 1001   | Date:              | 2017/03/21 |

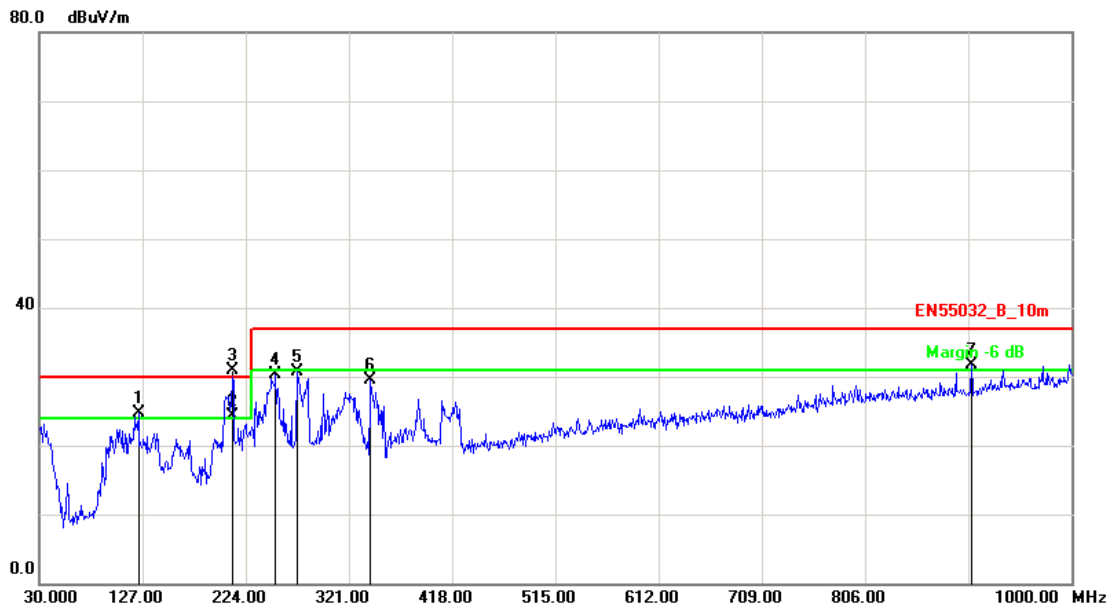

| No. | Frequency (MHz) | Factor (dB/m) | Reading (dBuV) | Level (dBuV/m) | Limit (dBuV/m) | Margin (dB) | Det. | Height (cm) | Azimuth (deg) |
|-----|-----------------|---------------|----------------|----------------|----------------|-------------|------|-------------|---------------|
| 1   | 123.1200        | -9.69         | 34.32          | 24.63          | 30.00          | -5.37       | peak | 100         | 284           |
| 2   | 211.3899        | -11.06        | 35.42          | 24.36          | 30.00          | -5.64       | QP   | 100         | 100           |
| 3   | 211.3900        | -11.06        | 41.91          | 30.85          | 30.00          | 0.85        | peak | 100         | 90            |
| 4   | 252.1300        | -10.36        | 40.70          | 30.34          | 37.00          | -6.66       | peak | 100         | 289           |
| 5   | 272.5000        | -9.28         | 40.05          | 30.77          | 37.00          | -6.23       | peak | 399         | 200           |
| 6   | 341.3700        | -7.73         | 37.30          | 29.57          | 37.00          | -7.43       | peak | 399         | 17            |
| 7   | 905.9100        | 3.57          | 28.12          | 31.69          | 37.00          | -5.31       | peak | 399         | 284           |

Note: Measurement Level = Reading Level + Correct Factor



|                  |   |                    |            |
|------------------|---|--------------------|------------|
| Test Mode :      | Mode 12: Full system (VGA mode 1920*1080@60Hz) Signal from PC (110V/60Hz) |                    |            |
| AC Power :       | AC 110V/60Hz  | Ant. Polarization: | Horizontal |
| Equipment :      | LCD Monitor   | Model No :         | 238LM00023 |
| Temperature :    | 22°C  | Humidity :         | 53%        |
| Pressure(mbar) : | 1001  | Date:              | 2017/03/21 |

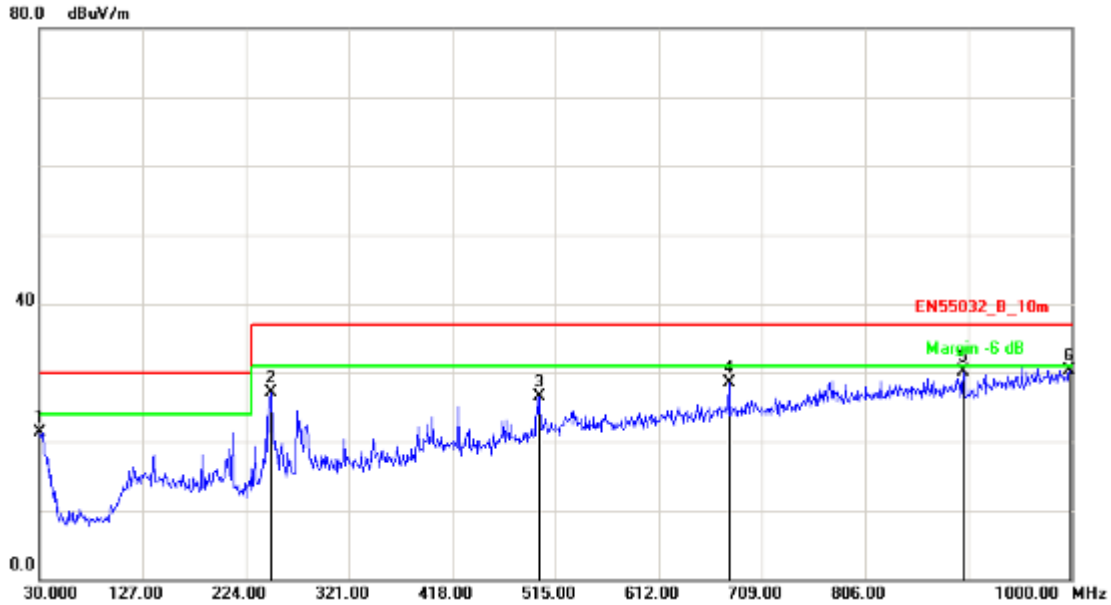

| No. | Frequency (MHz) | Factor (dB/m) | Reading (dBuV) | Level (dBuV/m) | Limit (dBuV/m) | Margin (dB) | Det. | Height (cm) | Azimuth (deg) |
|-----|-----------------|---------------|----------------|----------------|----------------|-------------|------|-------------|---------------|
| 1   | 30.0000         | -3.26         | 24.65          | 21.39          | 30.00          | -8.61       | peak | 100         | 55            |
| 2   | 247.2800        | -10.55        | 37.70          | 27.15          | 37.00          | -9.85       | peak | 100         | 35            |
| 3   | 500.4499        | -3.00         | 29.54          | 26.54          | 37.00          | -10.46      | peak | 100         | 196           |
| 4   | 677.9600        | -0.14         | 28.64          | 28.50          | 37.00          | -8.50       | peak | 100         | 161           |
| 5   | 898.1499        | 3.47          | 26.69          | 30.16          | 37.00          | -6.84       | peak | 100         | 318           |
| 6   | 998.0599        | 4.69          | 25.62          | 30.31          | 37.00          | -6.69       | peak | 100         | 77            |

Note: Measurement Level = Reading Level + Correct Factor



|                  |   |                    |            |
|------------------|---|--------------------|------------|
| Test Mode :      | Mode 12: Full system (VGA mode 1920*1080@60Hz) Signal from PC (110V/60Hz) |                    |            |
| AC Power :       | AC 110V/60Hz  | Ant. Polarization: | Vertical   |
| Equipment :      | LCD Monitor   | Model No :         | 238LM00023 |
| Temperature :    | 22°C  | Humidity :         | 53%        |
| Pressure(mbar) : | 1001  | Date:              | 2017/03/21 |

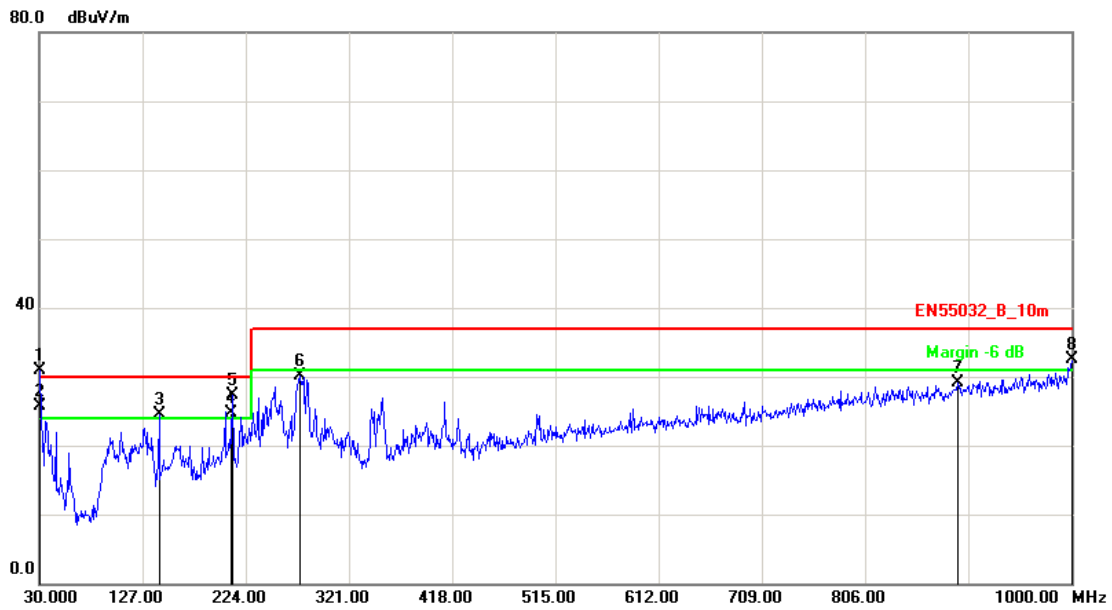

| No. | Frequency (MHz) | Factor (dB/m) | Reading (dBuV) | Level (dBuV/m) | Limit (dBuV/m) | Margin (dB) | Det. | Height (cm) | Azimuth (deg) |
|-----|-----------------|---------------|----------------|----------------|----------------|-------------|------|-------------|---------------|
| 1   | 30.0000         | -3.26         | 34.11          | 30.85          | 30.00          | 0.85        | peak | 100         | 300           |
| 2   | 30.3200         | -3.49         | 29.14          | 25.65          | 30.00          | -4.35       | QP   | 100         | 288           |
| 3   | 142.5200        | -10.48        | 34.93          | 24.45          | 30.00          | -5.55       | peak | 100         | 65            |
| 4   | 211.0150        | -11.03        | 35.72          | 24.69          | 30.00          | -5.31       | QP   | 100         | 320           |
| 5   | 211.3899        | -11.06        | 38.36          | 27.30          | 30.00          | -2.70       | peak | 100         | 325           |
| 6   | 275.4100        | -9.11         | 39.12          | 30.01          | 37.00          | -6.99       | peak | 100         | 344           |
| 7   | 893.3000        | 3.36          | 25.73          | 29.09          | 37.00          | -7.91       | peak | 100         | 45            |
| 8   | 1000.0000       | 4.68          | 27.82          | 32.50          | 37.00          | -4.50       | peak | 100         | 145           |

Note: Measurement Level = Reading Level + Correct Factor





|                  |   |                    |            |
|------------------|---|--------------------|------------|
| Test Mode :      | Mode 13: Full system (DISPLAY mode 2560*1440@60Hz) Signal from PC (110V/60Hz) |                    |            |
| AC Power :       | AC 110V/60Hz  | Ant. Polarization: | Horizontal |
| Equipment :      | LCD Monitor   | Model No :         | 238LM00023 |
| Temperature :    | 22°C  | Humidity :         | 53%        |
| Pressure(mbar) : | 1001  | Date:              | 2017/03/21 |

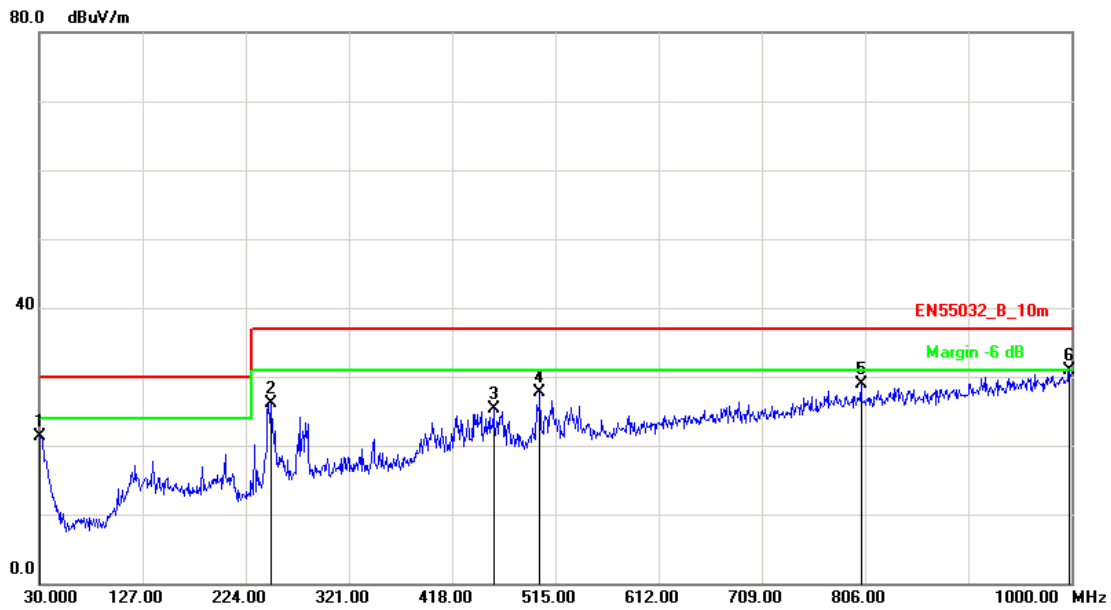

| No. | Frequency (MHz) | Factor (dB/m) | Reading (dBuV) | Level (dBuV/m) | Limit (dBuV/m) | Margin (dB) | Det. | Height (cm) | Azimuth (deg) |
|-----|-----------------|---------------|----------------|----------------|----------------|-------------|------|-------------|---------------|
| 1   | 30.0000         | -3.26         | 24.62          | 21.36          | 30.00          | -8.64       | peak | 100         | 146           |
| 2   | 247.2800        | -10.55        | 36.63          | 26.08          | 37.00          | -10.92      | peak | 100         | 219           |
| 3   | 456.8000        | -4.40         | 29.62          | 25.22          | 37.00          | -11.78      | peak | 100         | 122           |
| 4   | 500.4499        | -3.00         | 30.63          | 27.63          | 37.00          | -9.37       | peak | 100         | 272           |
| 5   | 802.1200        | 2.09          | 26.72          | 28.81          | 37.00          | -8.19       | peak | 100         | 89            |
| 6   | 998.0599        | 4.69          | 26.19          | 30.88          | 37.00          | -6.12       | peak | 100         | 179           |

Note: Measurement Level = Reading Level + Correct Factor



|                  |   |                    |            |
|------------------|---|--------------------|------------|
| Test Mode :      | Mode 13: Full system (DISPLAY mode 2560*1440@60Hz) Signal from PC (110V/60Hz) |                    |            |
| AC Power :       | AC 110V/60Hz  | Ant. Polarization: | Vertical   |
| Equipment :      | LCD Monitor   | Model No :         | 238LM00023 |
| Temperature :    | 22°C  | Humidity :         | 53%        |
| Pressure(mbar) : | 1001  | Date:              | 2017/03/21 |

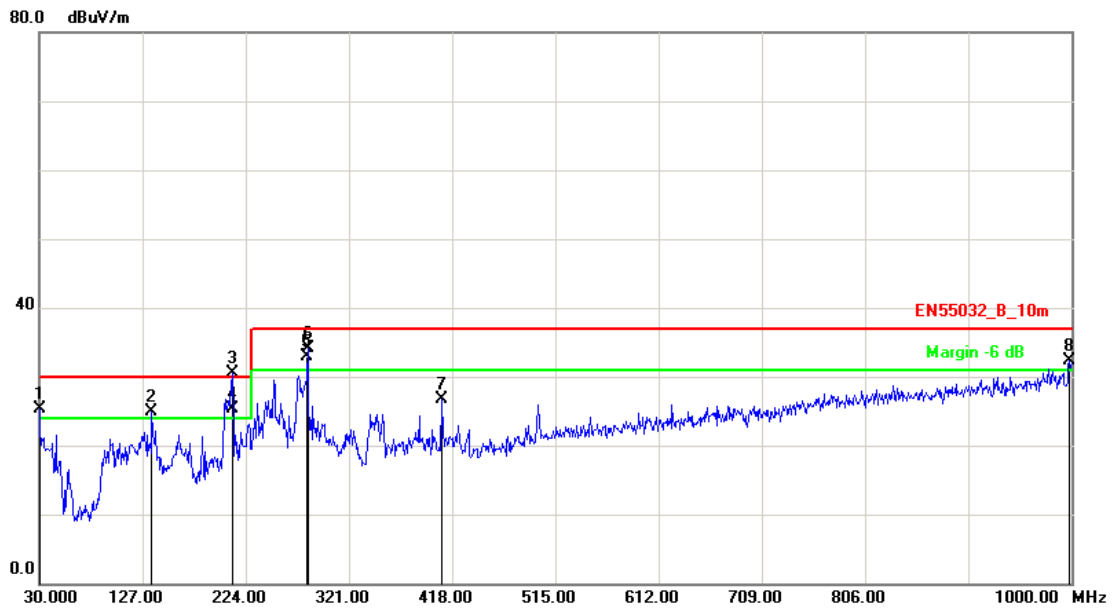

| No. | Frequency (MHz) | Factor (dB/m) | Reading (dBuV) | Level (dBuV/m) | Limit (dBuV/m) | Margin (dB) | Det. | Height (cm) | Azimuth (deg) |
|-----|-----------------|---------------|----------------|----------------|----------------|-------------|------|-------------|---------------|
| 1   | 30.0000         | -3.26         | 28.63          | 25.37          | 30.00          | -4.63       | peak | 200         | 35            |
| 2   | 135.7300        | -10.23        | 35.11          | 24.88          | 30.00          | -5.12       | peak | 100         | 123           |
| 3   | 211.3900        | -11.06        | 41.59          | 30.53          | 30.00          | 0.53        | peak | 100         | 322           |
| 4   | 211.6890        | -11.09        | 36.40          | 25.31          | 30.00          | -4.69       | QP   | 100         | 315           |
| 5   | 282.1999        | -8.82         | 41.80          | 32.98          | 37.00          | -4.02       | QP   | 100         | 360           |
| 6   | 282.2000        | -8.82         | 42.85          | 34.03          | 37.00          | -2.97       | peak | 100         | 349           |
| 7   | 408.3000        | -5.26         | 32.03          | 26.77          | 37.00          | -10.23      | peak | 100         | 280           |
| 8   | 998.0600        | 4.69          | 27.55          | 32.24          | 37.00          | -4.76       | peak | 100         | 159           |

Note: Measurement Level = Reading Level + Correct Factor



### 5.6. Test Result and Data (1GHz ~ 6GHz)

|                  |   |                    |            |
|------------------|---|--------------------|------------|
| Test Mode :      | Mode 1: Full system (HDMI mode 2560*1440@60Hz) Signal from PC (230V/50Hz) |                    |            |
| AC Power :       | AC 230V/50Hz  | Ant. Polarization: | Horizontal |
| Equipment :      | LCD Monitor   | Model No :         | 238LM00023 |
| Temperature :    | 22°C  | Humidity :         | 53%        |
| Pressure(mbar) : | 1001  | Date:              | 2017/03/21 |

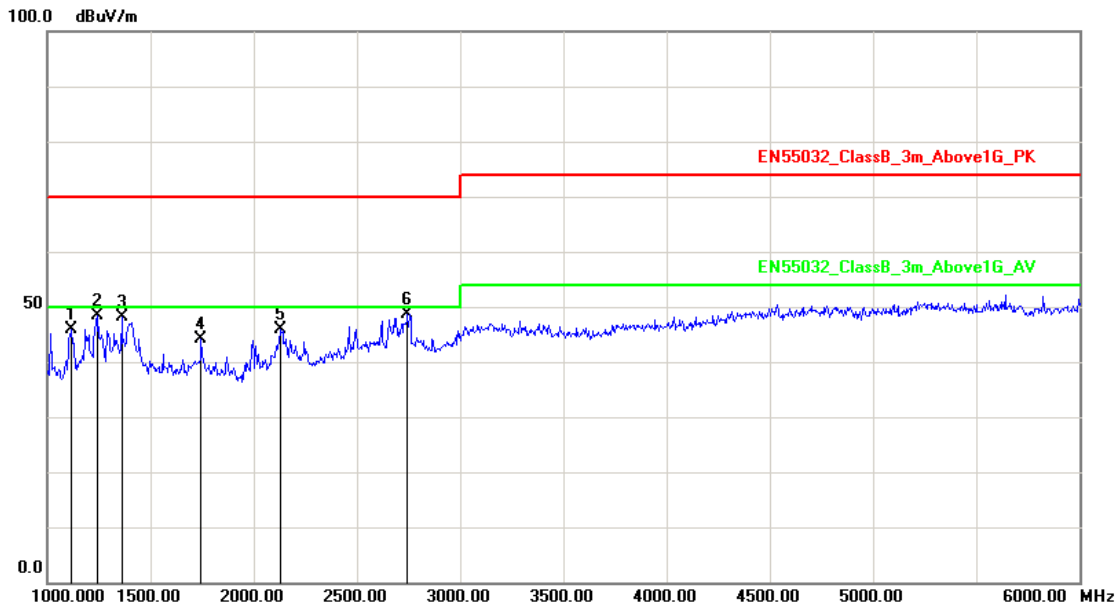

| No. | Frequency (MHz) | Factor (dB/m) | Reading (dBuV) | Level (dBuV/m) | Limit (dBuV/m) | Margin (dB) | Det. | Height (cm) | Azimuth (deg) |
|-----|-----------------|---------------|----------------|----------------|----------------|-------------|------|-------------|---------------|
| 1   | 1115.000        | -5.21         | 51.12          | 45.91          | 70.00          | -24.09      | peak | 200         | 64            |
| 2   | 1245.000        | -4.34         | 52.82          | 48.48          | 70.00          | -21.52      | peak | 200         | 157           |
| 3   | 1360.000        | -3.58         | 51.75          | 48.17          | 70.00          | -21.83      | peak | 100         | 42            |
| 4   | 1745.000        | -1.93         | 46.16          | 44.23          | 70.00          | -25.77      | peak | 200         | 36            |
| 5   | 2130.000        | -0.54         | 46.50          | 45.96          | 70.00          | -24.04      | peak | 100         | 192           |
| 6   | 2745.000        | 2.71          | 45.87          | 48.58          | 70.00          | -21.42      | peak | 200         | 0             |

Note: Measurement Level = Reading Level + Correct Factor



|                  |   |                    |            |
|------------------|---|--------------------|------------|
| Test Mode :      | Mode 1: Full system (HDMI mode 2560*1440@60Hz) Signal from PC (230V/50Hz) |                    |            |
| AC Power :       | AC 230V/50Hz  | Ant. Polarization: | Vertical   |
| Equipment :      | LCD Monitor   | Model No :         | 238LM00023 |
| Temperature :    | 22°C  | Humidity :         | 53%        |
| Pressure(mbar) : | 1001  | Date:              | 2017/03/21 |

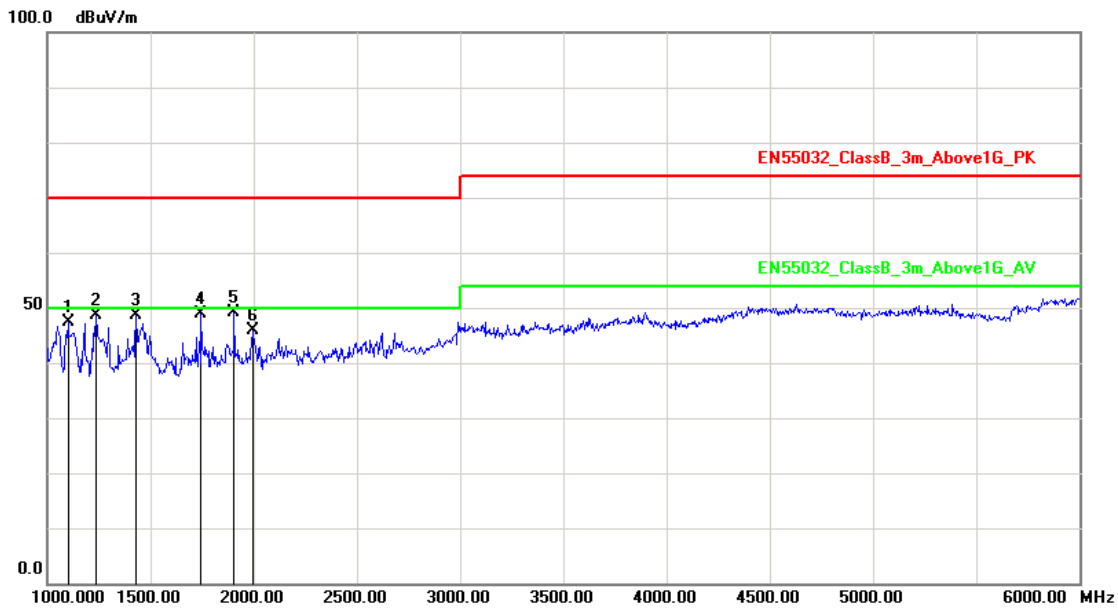

| No. | Frequency (MHz) | Factor (dB/m) | Reading (dBuV) | Level (dBuV/m) | Limit (dBuV/m) | Margin (dB) | Det. | Height (cm) | Azimuth (deg) |
|-----|-----------------|---------------|----------------|----------------|----------------|-------------|------|-------------|---------------|
| 1   | 1100.000        | -5.31         | 52.57          | 47.26          | 70.00          | -22.74      | peak | 200         | 253           |
| 2   | 1235.000        | -4.41         | 53.15          | 48.74          | 70.00          | -21.26      | peak | 200         | 154           |
| 3   | 1430.000        | -3.11         | 51.76          | 48.65          | 70.00          | -21.35      | peak | 100         | 0             |
| 4   | 1745.000        | -1.93         | 50.76          | 48.83          | 70.00          | -21.17      | peak | 100         | 218           |
| 5   | 1905.000        | -1.47         | 50.70          | 49.23          | 70.00          | -20.77      | peak | 100         | 330           |
| 6   | 1995.000        | -1.21         | 47.19          | 45.98          | 70.00          | -24.02      | peak | 100         | 16            |

Note: Measurement Level = Reading Level + Correct Factor



|                  |  |                    |            |
|------------------|--|--------------------|------------|
| Test Mode :      | Mode 5: Full system (VGA mode 1920*1080@60Hz) Signal from PC (230V/50Hz) |                    |            |
| AC Power :       | AC 230V/50Hz   | Ant. Polarization: | Horizontal |
| Equipment :      | LCD Monitor  | Model No :         | 238LM00023 |
| Temperature :    | 22°C   | Humidity :         | 53%        |
| Pressure(mbar) : | 1001   | Date:              | 2017/03/21 |

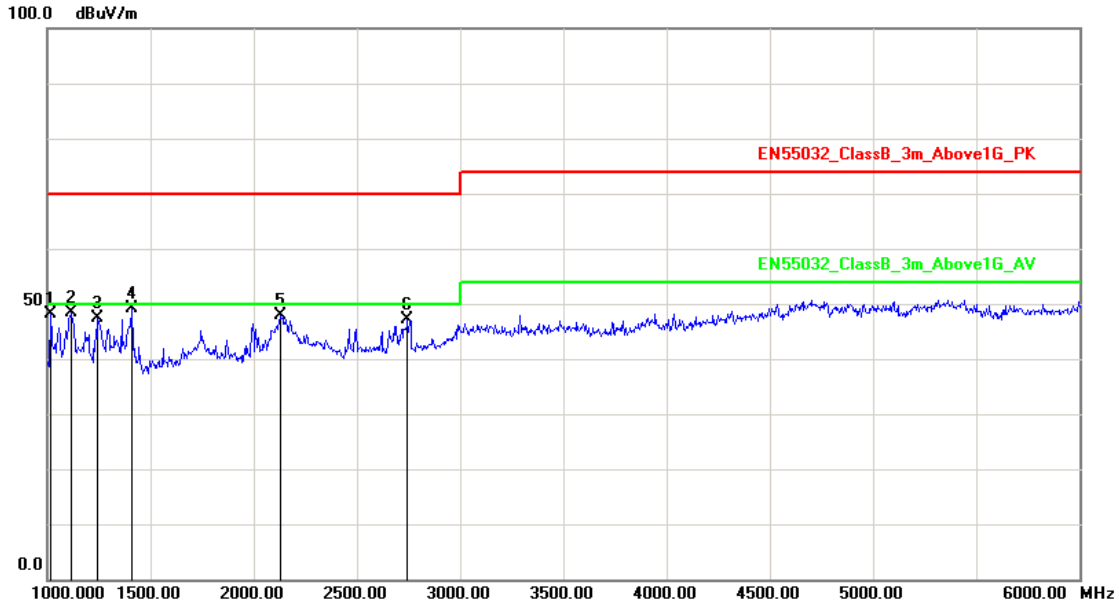

| No. | Frequency (MHz) | Factor (dB/m) | Reading (dBuV) | Level (dBuV/m) | Limit (dBuV/m) | Margin (dB) | Det. | Height (cm) | Azimuth (deg) |
|-----|-----------------|---------------|----------------|----------------|----------------|-------------|------|-------------|---------------|
| 1   | 1015.000        | -5.88         | 54.13          | 48.25          | 70.00          | -21.75      | peak | 200         | 284           |
| 2   | 1115.000        | -5.21         | 53.62          | 48.41          | 70.00          | -21.59      | peak | 200         | 339           |
| 3   | 1245.000        | -4.34         | 51.82          | 47.48          | 70.00          | -22.52      | peak | 200         | 115           |
| 4   | 1410.000        | -3.24         | 52.28          | 49.04          | 70.00          | -20.96      | peak | 100         | 0             |
| 5   | 2130.000        | -0.54         | 48.50          | 47.96          | 70.00          | -22.04      | peak | 200         | 324           |
| 6   | 2745.000        | 2.71          | 44.37          | 47.08          | 70.00          | -22.92      | peak | 100         | 187           |

Note: Measurement Level = Reading Level + Correct Factor



|                  |  |                    |            |
|------------------|--|--------------------|------------|
| Test Mode :      | Mode 5: Full system (VGA mode 1920*1080@60Hz) Signal from PC (230V/50Hz) |                    |            |
| AC Power :       | AC 230V/50Hz   | Ant. Polarization: | Vertical   |
| Equipment :      | LCD Monitor  | Model No :         | 238LM00023 |
| Temperature :    | 22°C   | Humidity :         | 53%        |
| Pressure(mbar) : | 1001   | Date:              | 2017/03/21 |

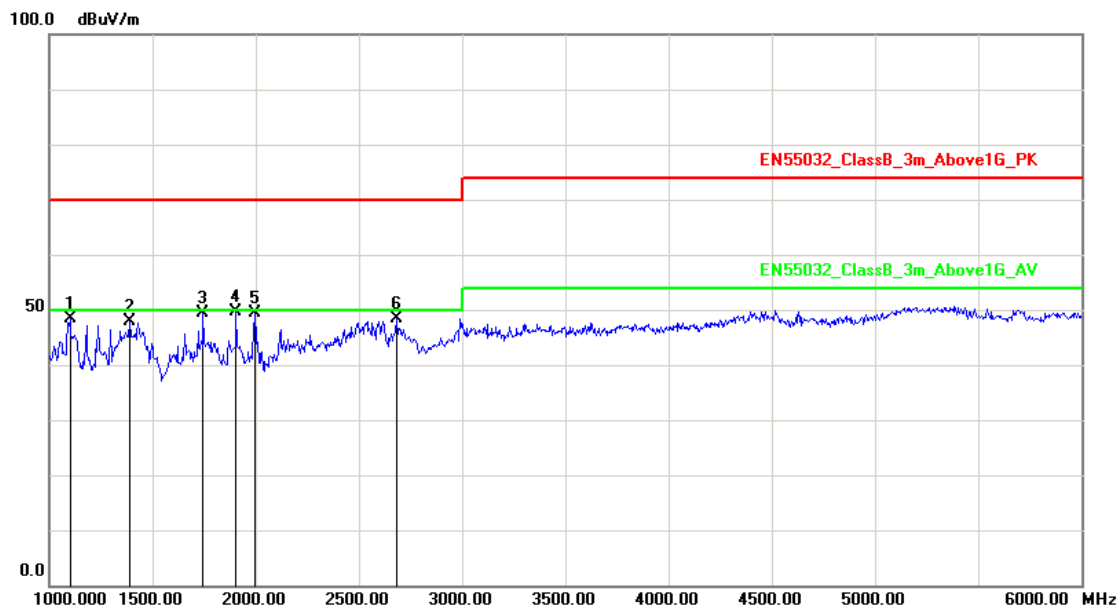

| No. | Frequency (MHz) | Factor (dB/m) | Reading (dBuV) | Level (dBuV/m) | Limit (dBuV/m) | Margin (dB) | Det. | Height (cm) | Azimuth (deg) |
|-----|-----------------|---------------|----------------|----------------|----------------|-------------|------|-------------|---------------|
| 1   | 1100.000        | -5.31         | 53.57          | 48.26          | 70.00          | -21.74      | peak | 200         | 69            |
| 2   | 1390.000        | -3.37         | 51.37          | 48.00          | 70.00          | -22.00      | peak | 100         | 355           |
| 3   | 1745.000        | -1.93         | 51.26          | 49.33          | 70.00          | -20.67      | peak | 100         | 332           |
| 4   | 1905.000        | -1.47         | 51.20          | 49.73          | 70.00          | -20.27      | peak | 100         | 61            |
| 5   | 1995.000        | -1.21         | 50.69          | 49.48          | 70.00          | -20.52      | peak | 200         | 0             |
| 6   | 2680.000        | 2.35          | 46.03          | 48.38          | 70.00          | -21.62      | peak | 200         | 148           |

Note: Measurement Level = Reading Level + Correct Factor



|                  |  |                    |            |
|------------------|--|--------------------|------------|
| Test Mode :      | Mode 8: Full system (DISPLAY mode 2560*1440@60Hz) Signal from PC (230V/50Hz) |                    |            |
| AC Power :       | AC 230V/50Hz   | Ant. Polarization: | Horizontal |
| Equipment :      | LCD Monitor  | Model No :         | 238LM00023 |
| Temperature :    | 22°C   | Humidity :         | 53%        |
| Pressure(mbar) : | 1001   | Date:              | 2017/03/21 |

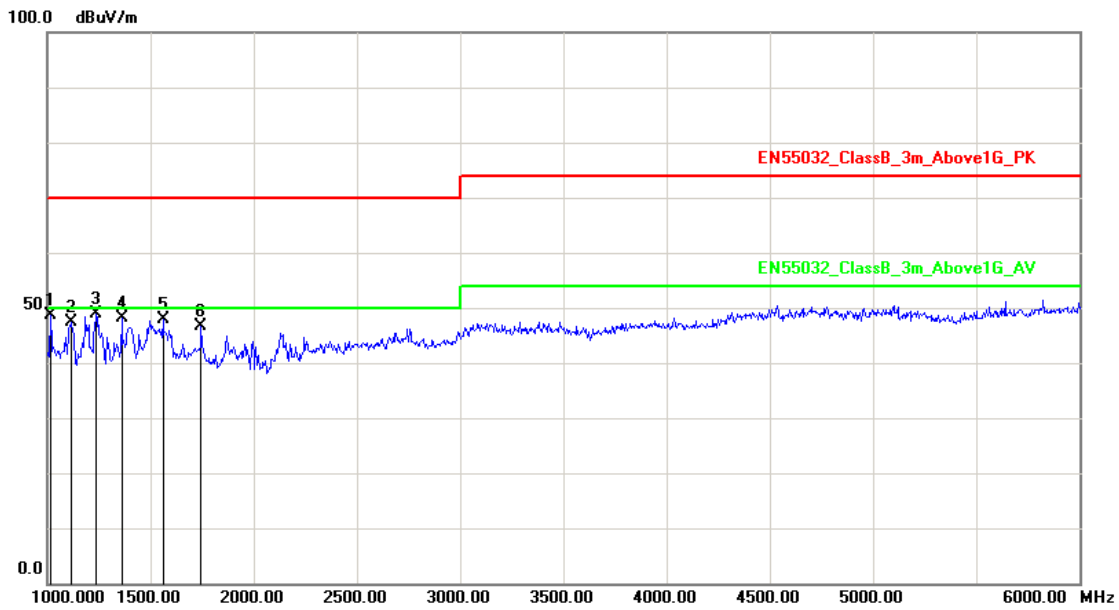

| No. | Frequency (MHz) | Factor (dB/m) | Reading (dBuV) | Level (dBuV/m) | Limit (dBuV/m) | Margin (dB) | Det. | Height (cm) | Azimuth (deg) |
|-----|-----------------|---------------|----------------|----------------|----------------|-------------|------|-------------|---------------|
| 1   | 1015.000        | -5.88         | 54.63          | 48.75          | 70.00          | -21.25      | peak | 200         | 61            |
| 2   | 1115.000        | -5.21         | 52.62          | 47.41          | 70.00          | -22.59      | peak | 200         | 0             |
| 3   | 1235.000        | -4.41         | 53.21          | 48.80          | 70.00          | -21.20      | peak | 200         | 187           |
| 4   | 1360.000        | -3.58         | 51.75          | 48.17          | 70.00          | -21.83      | peak | 100         | 0             |
| 5   | 1560.000        | -2.47         | 50.31          | 47.84          | 70.00          | -22.16      | peak | 200         | 49            |
| 6   | 1745.000        | -1.93         | 48.66          | 46.73          | 70.00          | -23.27      | peak | 200         | 215           |

Note: Measurement Level = Reading Level + Correct Factor



|                  |  |                    |            |
|------------------|--|--------------------|------------|
| Test Mode :      | Mode 8: Full system (DISPLAY mode 2560*1440@60Hz) Signal from PC (230V/50Hz) |                    |            |
| AC Power :       | AC 230V/50Hz   | Ant. Polarization: | Vertical   |
| Equipment :      | LCD Monitor  | Model No :         | 238LM00023 |
| Temperature :    | 22°C   | Humidity :         | 53%        |
| Pressure(mbar) : | 1001   | Date:              | 2017/03/21 |

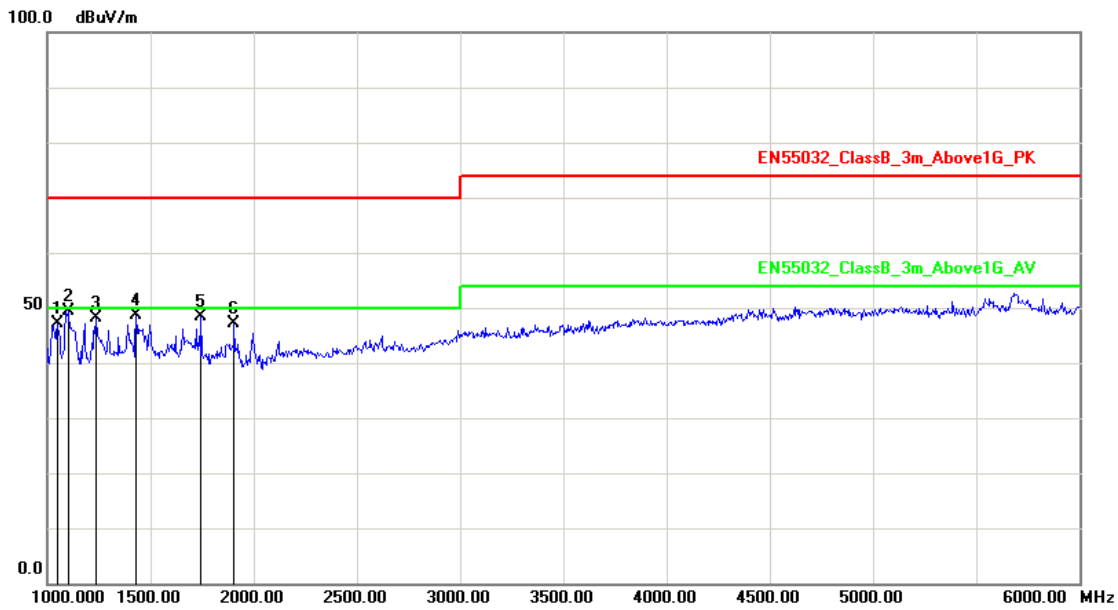

| No. | Frequency (MHz) | Factor (dB/m) | Reading (dBuV) | Level (dBuV/m) | Limit (dBuV/m) | Margin (dB) | Det. | Height (cm) | Azimuth (deg) |
|-----|-----------------|---------------|----------------|----------------|----------------|-------------|------|-------------|---------------|
| 1   | 1050.000        | -5.65         | 52.77          | 47.12          | 70.00          | -22.88      | peak | 100         | 156           |
| 2   | 1100.000        | -5.31         | 54.57          | 49.26          | 70.00          | -20.74      | peak | 100         | 61            |
| 3   | 1235.000        | -4.41         | 52.65          | 48.24          | 70.00          | -21.76      | peak | 200         | 0             |
| 4   | 1430.000        | -3.11         | 51.76          | 48.65          | 70.00          | -21.35      | peak | 100         | 223           |
| 5   | 1745.000        | -1.93         | 50.26          | 48.33          | 70.00          | -21.67      | peak | 100         | 298           |
| 6   | 1905.000        | -1.47         | 48.70          | 47.23          | 70.00          | -22.77      | peak | 200         | 7             |

Note: Measurement Level = Reading Level + Correct Factor





|                  |  |                    |            |
|------------------|--|--------------------|------------|
| Test Mode :      | Mode 11: Full system (HDMI mode 2560*1440@60Hz) Signal from PC (110V/60Hz) |                    |            |
| AC Power :       | AC 110V/60Hz   | Ant. Polarization: | Horizontal |
| Equipment :      | LCD Monitor  | Model No :         | 238LM00023 |
| Temperature :    | 22°C   | Humidity :         | 53%        |
| Pressure(mbar) : | 1001   | Date:              | 2017/03/21 |

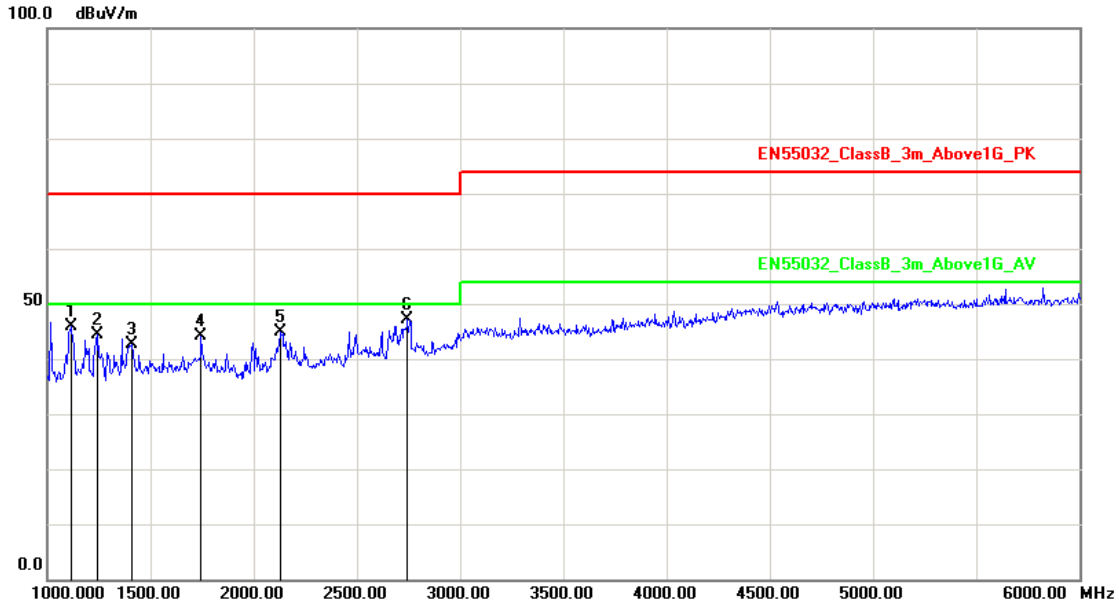

| No. | Frequency (MHz) | Factor (dB/m) | Reading (dBuV) | Level (dBuV/m) | Limit (dBuV/m) | Margin (dB) | Det. | Height (cm) | Azimuth (deg) |
|-----|-----------------|---------------|----------------|----------------|----------------|-------------|------|-------------|---------------|
| 1   | 1115.000        | -5.21         | 51.12          | 45.91          | 70.00          | -24.09      | peak | 180         | 360           |
| 2   | 1245.000        | -4.34         | 48.82          | 44.48          | 70.00          | -25.52      | peak | 130         | 360           |
| 3   | 1410.000        | -3.24         | 45.78          | 42.54          | 70.00          | -27.46      | peak | 100         | 334           |
| 4   | 1745.000        | -1.93         | 46.16          | 44.23          | 70.00          | -25.77      | peak | 100         | 230           |
| 5   | 2130.000        | -0.54         | 45.50          | 44.96          | 70.00          | -25.04      | peak | 171         | 360           |
| 6   | 2745.000        | 2.71          | 44.37          | 47.08          | 70.00          | -22.92      | peak | 100         | 1             |

Note: Measurement Level = Reading Level + Correct Factor



|                  |  |                    |            |
|------------------|--|--------------------|------------|
| Test Mode :      | Mode 11: Full system (HDMI mode 2560*1440@60Hz) Signal from PC (110V/60Hz) |                    |            |
| AC Power :       | AC 110V/60Hz   | Ant. Polarization: | Vertical   |
| Equipment :      | LCD Monitor  | Model No :         | 238LM00023 |
| Temperature :    | 22°C   | Humidity :         | 53%        |
| Pressure(mbar) : | 1001   | Date:              | 2017/03/21 |

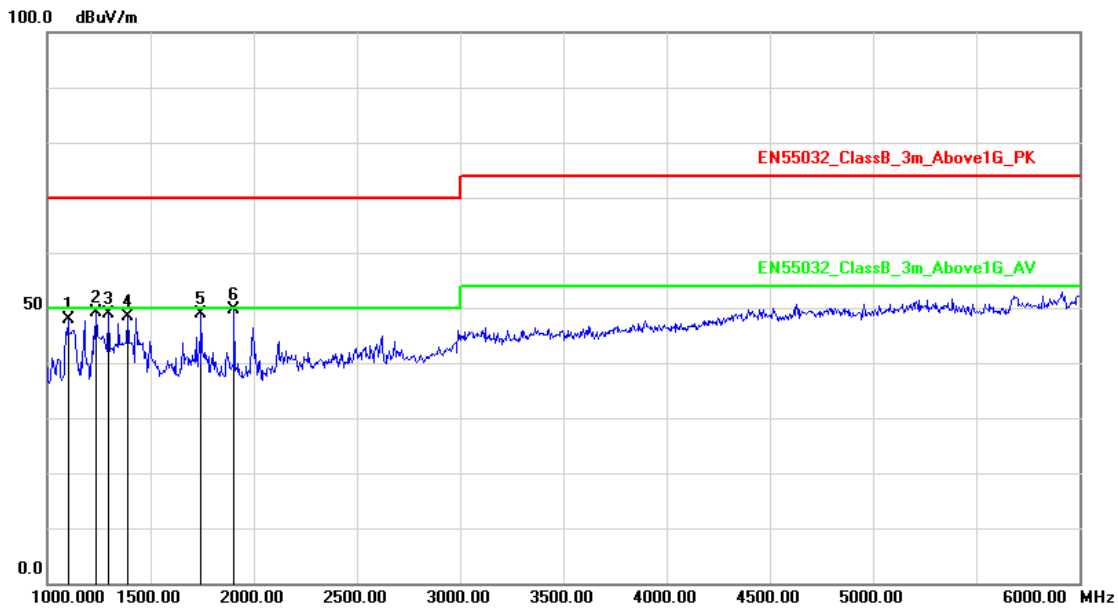

| No. | Frequency (MHz) | Factor (dB/m) | Reading (dBuV) | Level (dBuV/m) | Limit (dBuV/m) | Margin (dB) | Det. | Height (cm) | Azimuth (deg) |
|-----|-----------------|---------------|----------------|----------------|----------------|-------------|------|-------------|---------------|
| 1   | 1100.000        | -5.31         | 53.07          | 47.76          | 70.00          | -22.24      | peak | 200         | 0             |
| 2   | 1235.000        | -4.41         | 53.65          | 49.24          | 70.00          | -20.76      | peak | 100         | 157           |
| 3   | 1295.000        | -4.01         | 52.78          | 48.77          | 70.00          | -21.23      | peak | 200         | 48            |
| 4   | 1390.000        | -3.37         | 51.87          | 48.50          | 70.00          | -21.50      | peak | 200         | 329           |
| 5   | 1745.000        | -1.93         | 50.76          | 48.83          | 70.00          | -21.17      | peak | 100         | 61            |
| 6   | 1905.000        | -1.47         | 51.20          | 49.73          | 70.00          | -20.27      | peak | 100         | 241           |

Note: Measurement Level = Reading Level + Correct Factor



|                  |   |                    |            |
|------------------|---|--------------------|------------|
| Test Mode :      | Mode 12: Full system (VGA mode 1920*1080@60Hz) Signal from PC (110V/60Hz) |                    |            |
| AC Power :       | AC 110V/60Hz  | Ant. Polarization: | Horizontal |
| Equipment :      | LCD Monitor   | Model No :         | 238LM00023 |
| Temperature :    | 22°C  | Humidity :         | 53%        |
| Pressure(mbar) : | 1001  | Date:              | 2017/03/21 |

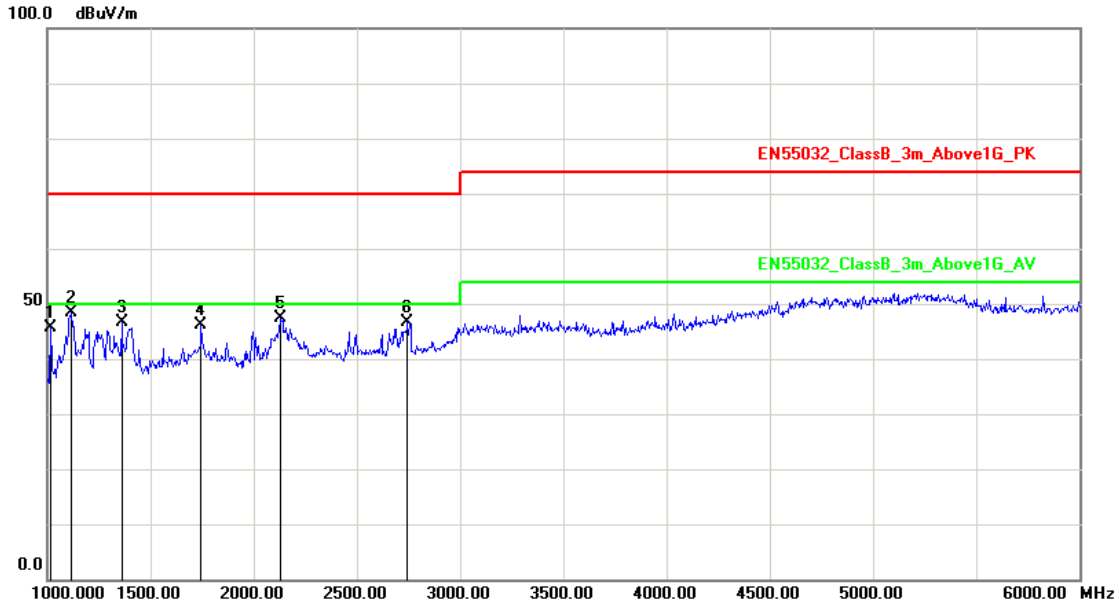

| No. | Frequency (MHz) | Factor (dB/m) | Reading (dBuV) | Level (dBuV/m) | Limit (dBuV/m) | Margin (dB) | Det. | Height (cm) | Azimuth (deg) |
|-----|-----------------|---------------|----------------|----------------|----------------|-------------|------|-------------|---------------|
| 1   | 1015.000        | -5.88         | 51.63          | 45.75          | 70.00          | -24.25      | peak | 200         | 198           |
| 2   | 1115.000        | -5.21         | 53.62          | 48.41          | 70.00          | -21.59      | peak | 100         | 0             |
| 3   | 1360.000        | -3.58         | 50.25          | 46.67          | 70.00          | -23.33      | peak | 200         | 214           |
| 4   | 1745.000        | -1.93         | 48.16          | 46.23          | 70.00          | -23.77      | peak | 200         | 63            |
| 5   | 2130.000        | -0.54         | 48.00          | 47.46          | 70.00          | -22.54      | peak | 200         | 115           |
| 6   | 2745.000        | 2.71          | 43.87          | 46.58          | 70.00          | -23.42      | peak | 100         | 47            |

Note: Measurement Level = Reading Level + Correct Factor



|                  |   |                    |            |
|------------------|---|--------------------|------------|
| Test Mode :      | Mode 12: Full system (VGA mode 1920*1080@60Hz) Signal from PC (110V/60Hz) |                    |            |
| AC Power :       | AC 110V/60Hz  | Ant. Polarization: | Vertical   |
| Equipment :      | LCD Monitor   | Model No :         | 238LM00023 |
| Temperature :    | 22°C  | Humidity :         | 53%        |
| Pressure(mbar) : | 1001  | Date:              | 2017/03/21 |

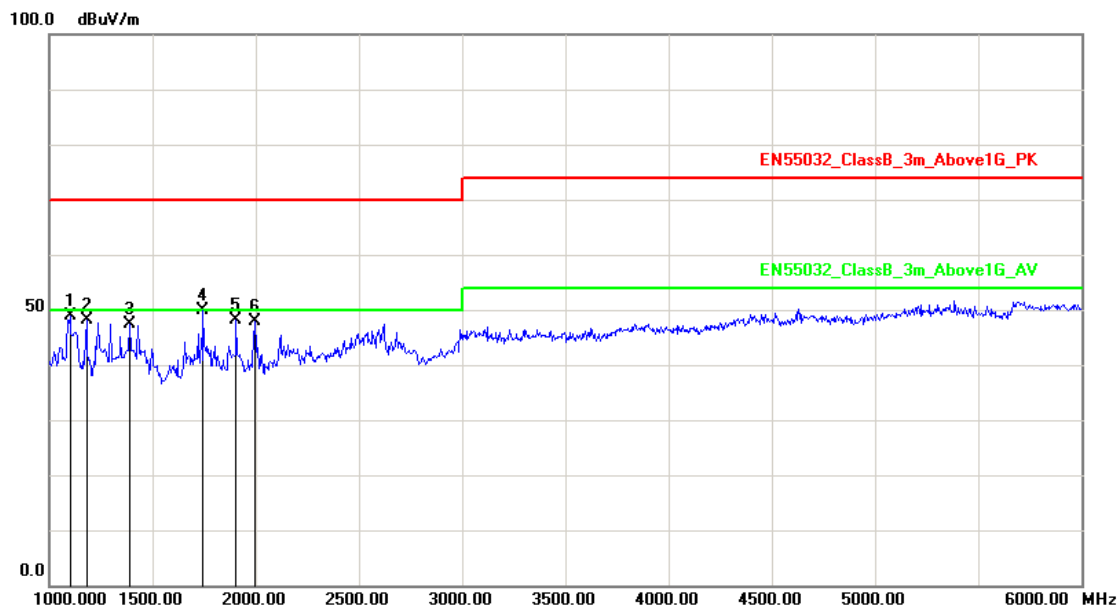

| No. | Frequency (MHz) | Factor (dB/m) | Reading (dBuV) | Level (dBuV/m) | Limit (dBuV/m) | Margin (dB) | Det. | Height (cm) | Azimuth (deg) |
|-----|-----------------|---------------|----------------|----------------|----------------|-------------|------|-------------|---------------|
| 1   | 1100.000        | -5.31         | 54.07          | 48.76          | 70.00          | -21.24      | peak | 100         | 0             |
| 2   | 1180.000        | -4.78         | 52.96          | 48.18          | 70.00          | -21.82      | peak | 100         | 115           |
| 3   | 1390.000        | -3.37         | 50.87          | 47.50          | 70.00          | -22.50      | peak | 200         | 0             |
| 4   | 1745.000        | -1.93         | 51.76          | 49.83          | 70.00          | -20.17      | peak | 200         | 326           |
| 5   | 1905.000        | -1.47         | 49.70          | 48.23          | 70.00          | -21.77      | peak | 100         | 326           |
| 6   | 1995.000        | -1.21         | 49.19          | 47.98          | 70.00          | -22.02      | peak | 100         | 31            |

Note: Measurement Level = Reading Level + Correct Factor



|                  |   |                    |            |
|------------------|---|--------------------|------------|
| Test Mode :      | Mode 13: Full system (DISPLAY mode 2560*1440@60Hz) Signal from PC (110V/60Hz) |                    |            |
| AC Power :       | AC 110V/60Hz  | Ant. Polarization: | Horizontal |
| Equipment :      | LCD Monitor   | Model No :         | 238LM00023 |
| Temperature :    | 22°C  | Humidity :         | 53%        |
| Pressure(mbar) : | 1001  | Date:              | 2017/03/21 |

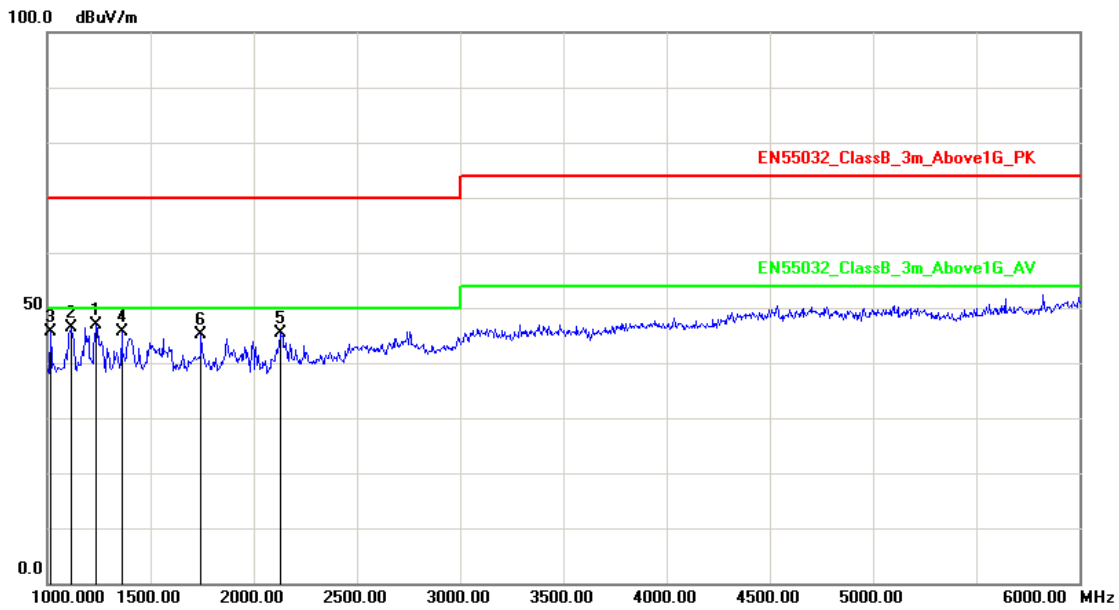

| No. | Frequency (MHz) | Factor (dB/m) | Reading (dBuV) | Level (dBuV/m) | Limit (dBuV/m) | Margin (dB) | Det. | Height (cm) | Azimuth (deg) |
|-----|-----------------|---------------|----------------|----------------|----------------|-------------|------|-------------|---------------|
| 1   | 1235.000        | -4.41         | 51.21          | 46.80          | 70.00          | -23.20      | peak | 200         | 331           |
| 2   | 1115.000        | -5.21         | 51.62          | 46.41          | 70.00          | -23.59      | peak | 200         | 268           |
| 3   | 1015.000        | -5.88         | 51.63          | 45.75          | 70.00          | -24.25      | peak | 100         | 54            |
| 4   | 1360.000        | -3.58         | 49.25          | 45.67          | 70.00          | -24.33      | peak | 200         | 0             |
| 5   | 2130.000        | -0.54         | 46.00          | 45.46          | 70.00          | -24.54      | peak | 100         | 188           |
| 6   | 1745.000        | -1.93         | 47.16          | 45.23          | 70.00          | -24.77      | peak | 200         | 49            |

Note: Measurement Level = Reading Level + Correct Factor



|                  |   |                    |            |
|------------------|---|--------------------|------------|
| Test Mode :      | Mode 13: Full system (DISPLAY mode 2560*1440@60Hz) Signal from PC (110V/60Hz) |                    |            |
| AC Power :       | AC 110V/60Hz  | Ant. Polarization: | Vertical   |
| Equipment :      | LCD Monitor   | Model No :         | 238LM00023 |
| Temperature :    | 22°C  | Humidity :         | 53%        |
| Pressure(mbar) : | 1001  | Date:              | 2017/03/21 |

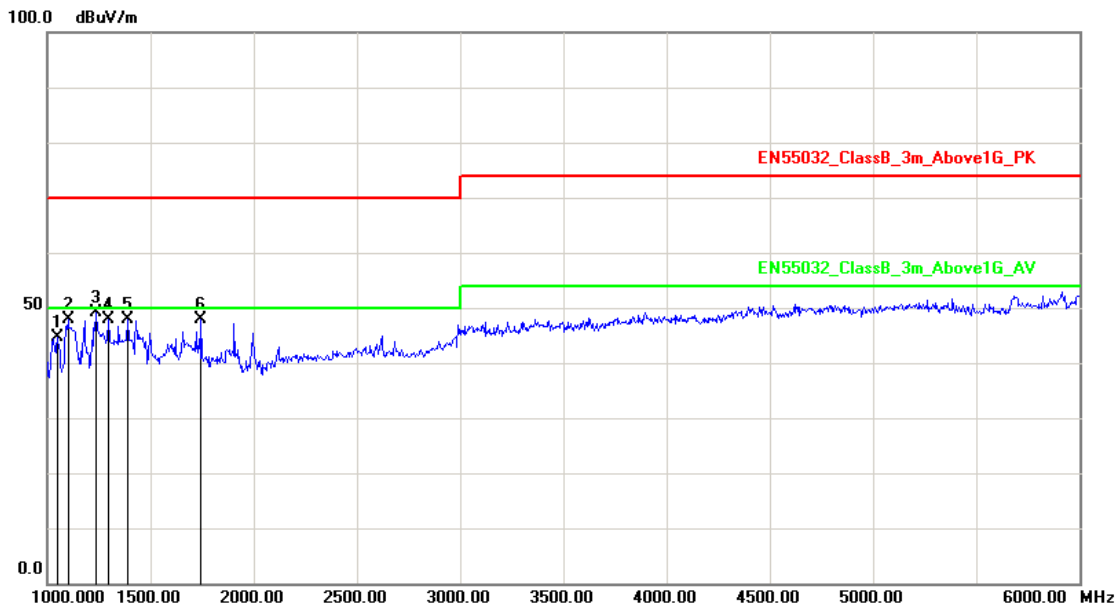

| No. | Frequency (MHz) | Factor (dB/m) | Reading (dBuV) | Level (dBuV/m) | Limit (dBuV/m) | Margin (dB) | Det. | Height (cm) | Azimuth (deg) |
|-----|-----------------|---------------|----------------|----------------|----------------|-------------|------|-------------|---------------|
| 1   | 1050.000        | -5.65         | 50.27          | 44.62          | 70.00          | -25.38      | peak | 200         | 0             |
| 2   | 1100.000        | -5.31         | 53.07          | 47.76          | 70.00          | -22.24      | peak | 100         | 52            |
| 3   | 1235.000        | -4.41         | 53.65          | 49.24          | 70.00          | -20.76      | peak | 100         | 132           |
| 4   | 1295.000        | -4.01         | 51.78          | 47.77          | 70.00          | -22.23      | peak | 200         | 116           |
| 5   | 1390.000        | -3.37         | 51.37          | 48.00          | 70.00          | -22.00      | peak | 200         | 168           |
| 6   | 1745.000        | -1.93         | 49.76          | 47.83          | 70.00          | -22.17      | peak | 100         | 0             |

Note: Measurement Level = Reading Level + Correct Factor

Test engineer: Sun. Zhang



### 5.7. Test Photographs (30MHz~1GHz)

Front View



Rear View

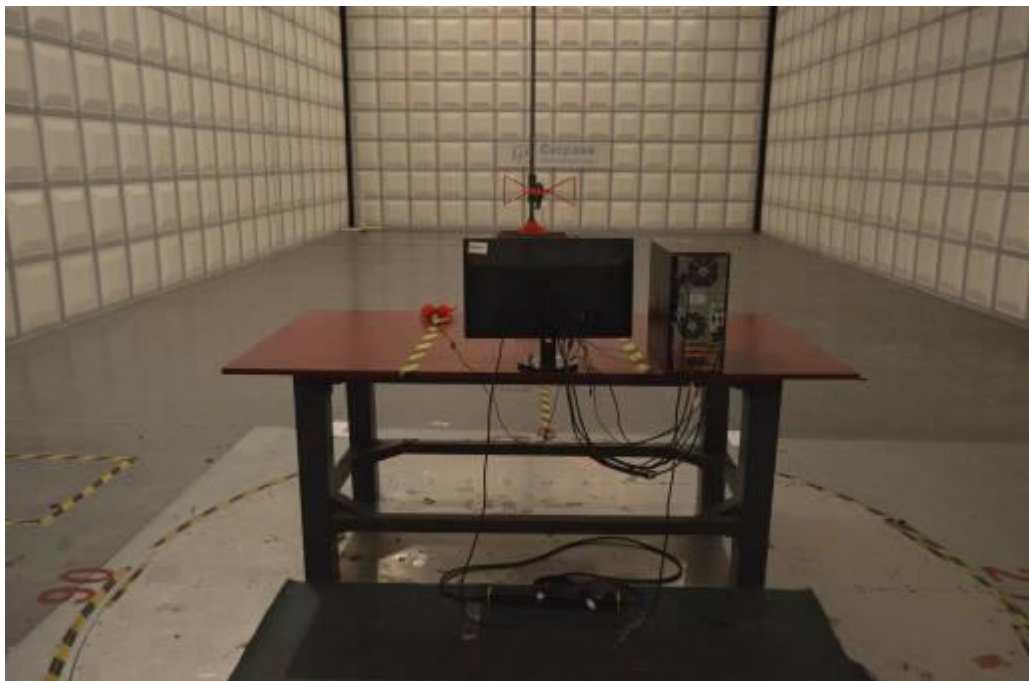



### 5.8. Test Photographs (1GHz~6GHz)

Front View



Rear View

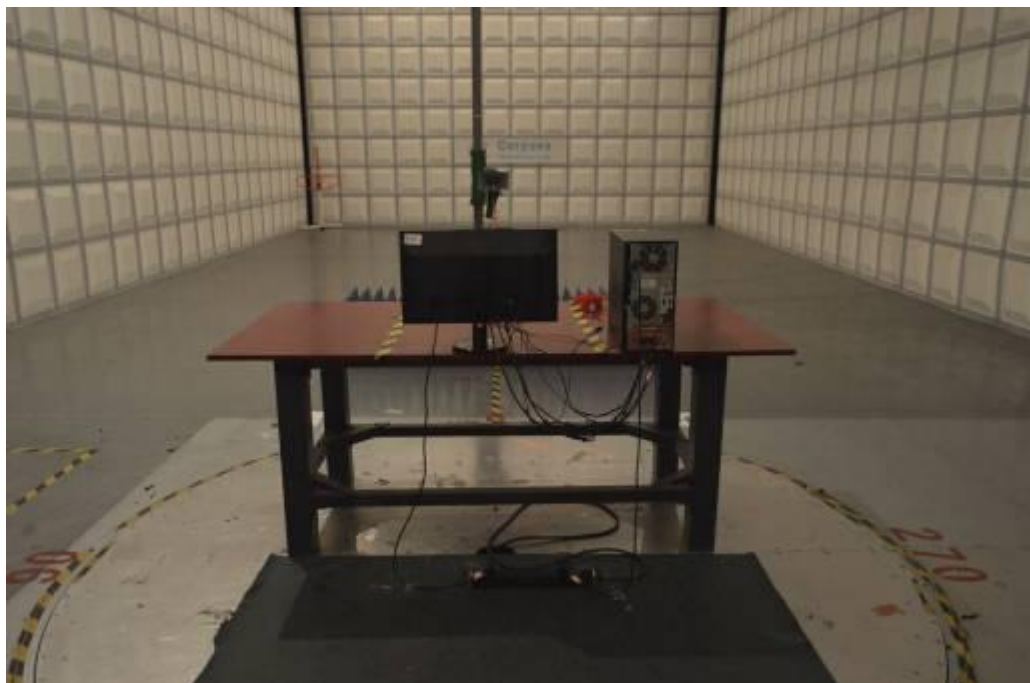





## 6. Harmonics Test

### 6.1. Limits of Harmonics Current Measurement

#### Limits for Class A equipment

| Harmonics Order<br>n | Max. permissible<br>harmonics current<br>A | Harmonics Order<br>n | Max. permissible<br>harmonics current<br>A |
|----------------------|--|----------------------|--|
| Odd harmonics        |  | Even harmonics       |  |
| 3                    | 2.30                                       | 2                    | 1.08                                       |
| 5                    | 1.14                                       | 4                    | 0.43                                       |
| 7                    | 0.77                                       | 6                    | 0.30                                       |
| 9                    | 0.40                                       | 8<=n<=40             | 0.23x8/n                                   |
| 11                   | 0.33                                       |                      |  |
| 13                   | 0.21                                       |                      |  |
| 15<=n<=39            | 0.15x15/n                                  |                      |  |

#### (b) Limits for Class B equipment

For Class B equipment, the harmonics of the input current shall not exceed the values given in Table that is the limit of Class A multiplied by a factor of 1,5.

#### (c) Limits for Class C equipment

| Harmonics Order<br>n            | Maximum permissible harmonic current expressed as a percentage of the input current at the fundamental frequency<br>% |
|---------------------------------|---|
| 2                               | 2   |
| 3                               | $30 \cdot \lambda^*$  |
| 5                               | 10  |
| 7                               | 7   |
| 9                               | 5   |
| 11<n<39<br>(odd harmonics only) | 3   |

\*  $\lambda$  is the circuit power factor

#### (d) Limits for Class D equipment

| Harmonics Order<br>n                | Maximum permissible<br>harmonic current per watt<br>mA/W | Maximum permissible<br>harmonic current<br>A |
|-------------------------------------|--|--|
| 3                                   | 3.4  | 2.30   |
| 5                                   | 1.9  | 1.14   |
| 7                                   | 1.0  | 0.77   |
| 9                                   | 0.5  | 0.40   |
| 11                                  | 0.35   | 0.33   |
| 11 < n < 39<br>(odd harmonics only) | 3.85/n   | See limit of Class A                         |

**NOTE:** According to section 7 of EN 61000-3-2, the above limits for all equipment except for lighting equipment having an active input power > 75 W and no limits apply for equipment with an active input power up to and including 75 W.



### 6.2. Measurement Equipment

| Instrument/Ancillary           | Manufacturer      | Model No.      | Serial No. | Calibration Date | Valid Date. |
|--------------------------------|-------------------|----------------|------------|------------------|-------------|
| EMC Emission Tester            | EMCPARTNER        | Harmonics-1000 | 159        | 2016.03.26       | 2017.03.25  |
| Temperature/<br>Humidity Meter | Zhicheng          | ZC1-11         | CEP-TH-004 | 2016.03.29       | 2017.03.28  |
| HARCS                          | EMC Partner<br>AG | Ver 4.18       | N/A        | N/A              | N/A         |



6.3. Test Result and Data

|                      |   |              |
|----------------------|---|--------------|
| Basic Standard       | : | EN 61000-3-2 |
| Final Test Result    | : | PASS         |
| Test Mode            | : | Mode 1,5,8   |
| Model No.            | : | 238LM00023   |
| Temperature          | : | 22°C         |
| Humidity             | : | 56%          |
| Atmospheric Pressure | : | 100 kPa      |
| Test Date            | : | Mar 22, 2017 |

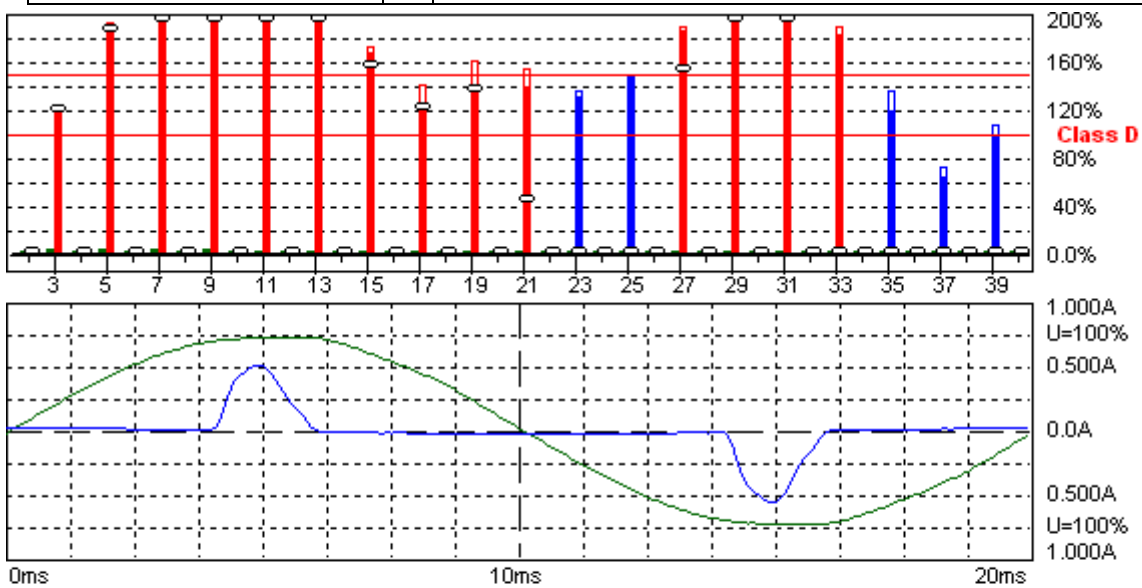

Harmonic Emission - IEC 61000-3-2 , EN 61000-3-2 , (EN60555-2)

2017-3-22 9:23:30 harmonic.hsu

|                |             |                |                         |
|----------------|-------------|----------------|-------------------------|
| Urms = 229.9 V | P = 19.71 W | THC = 0.136 A  | Range: 1 A              |
| Irms = 0.160 A | pf = 0.535  | Pmax = 19.78 W | V-nom: 230 V            |
|                |             |                | TestTime: 15 min (100%) |

HAR-1000 EMC-Parber

Full Bar : Actual Values

Empty Bar : Maximum Values

Blue : Current , Green : Voltage , Red : Failed

Urms = 229.9V Freq = 50.013 Range: 1 A  
 Irms = 0.160A lpk = 0.562A cf = 3.509  
 P = 19.71W S = 36.82VA pf = 0.535  
 THDi = 83.5 % THDu = 1.40 % Class D  
 Test - Time : 15min ( 100 %)  
 Limit Reference: Pmax = 19.781W  
 Test completed, Result: PASSED



| Order | Freq. [Hz] | Irms [A] | Irms%L [%] | I <sub>max</sub> [A] | I <sub>max</sub> %L [%] | Limit [A] | Status |
|-------|------------|----------|------------|----------------------|-------------------------|-----------|--------|
| 1     | 50         | 0.0894   |            | 0.0897               |                         |           |        |
| 2     | 100        | 0.0038   |            | 0.0039               |                         |           |        |
| 3     | 150        | 0.0812   | 120.70     | 0.0813               | 120.88                  | 0.00      | N/L    |
| 4     | 200        | 0.0040   |            | 0.0043               |                         |           |        |
| 5     | 250        | 0.0714   | 189.84     | 0.0715               | 190.33                  | 0.00      | N/L    |
| 6     | 300        | 0.0039   |            | 0.0040               |                         |           |        |
| 7     | 350        | 0.0583   | 294.67     | 0.0587               | 296.83                  | 0.00      | N/L    |
| 8     | 400        | 0.0033   |            | 0.0034               |                         |           |        |
| 9     | 450        | 0.0428   | 432.59     | 0.0432               | 436.30                  | 0.00      | N/L    |
| 10    | 500        | 0.0026   |            | 0.0027               |                         |           |        |
| 11    | 550        | 0.0287   | 415.23     | 0.0292               | 421.40                  | 0.00      | N/L    |
| 12    | 600        | 0.0014   |            | 0.0015               |                         |           |        |
| 13    | 650        | 0.0167   | 284.43     | 0.0171               | 291.72                  | 0.00      | N/L    |
| 14    | 700        | 0.0006   |            | 0.0009               |                         |           |        |
| 15    | 750        | 0.0084   | 165.90     | 0.0087               | 170.71                  | 0.00      | N/L    |
| 16    | 800        | 0.0007   |            | 0.0007               |                         |           |        |
| 17    | 850        | 0.0053   | 118.53     | 0.0062               | 138.97                  | 0.00      | N/L    |
| 18    | 900        | 0.0012   |            | 0.0013               |                         |           |        |
| 19    | 950        | 0.0053   | 132.48     | 0.0064               | 159.89                  | 0.00      | N/L    |
| 20    | 1000       | 0.0014   |            | 0.0015               |                         |           |        |
| 21    | 1050       | 0.0049   | 136.32     | 0.0055               | 151.47                  | 0.00      | N/L    |
| 22    | 1100       | 0.0013   |            | 0.0013               |                         |           |        |
| 23    | 1150       | 0.0043   | 129.03     | 0.0044               | 132.72                  | 0.00      | N/L    |
| 24    | 1200       | 0.0010   |            | 0.0010               |                         |           |        |
| 25    | 1250       | 0.0044   | 144.26     | 0.0045               | 146.26                  | 0.00      | N/L    |
| 26    | 1300       | 0.0005   |            | 0.0006               |                         |           |        |
| 27    | 1350       | 0.0052   | 183.93     | 0.0052               | 186.09                  | 0.00      | N/L    |
| 28    | 1400       | 0.0005   |            | 0.0006               |                         |           |        |
| 29    | 1450       | 0.0058   | 220.80     | 0.0059               | 223.12                  | 0.00      | N/L    |
| 30    | 1500       | 0.0007   |            | 0.0008               |                         |           |        |
| 31    | 1550       | 0.0054   | 221.12     | 0.0056               | 226.09                  | 0.00      | N/L    |
| 32    | 1600       | 0.0009   |            | 0.0009               |                         |           |        |
| 33    | 1650       | 0.0042   | 182.49     | 0.0043               | 187.78                  | 0.00      | N/L    |
| 34    | 1700       | 0.0007   |            | 0.0008               |                         |           |        |
| 35    | 1750       | 0.0026   | 117.81     | 0.0029               | 134.64                  | 0.00      | N/L    |
| 36    | 1800       | 0.0007   |            | 0.0007               |                         |           |        |
| 37    | 1850       | 0.0013   | 62.272     | 0.0015               | 71.168                  | 0.00      | N/L    |
| 38    | 1900       | 0.0005   |            | 0.0007               |                         |           |        |
| 39    | 1950       | 0.0019   | 96.894     | 0.0021               | 106.27                  | 0.00      | N/L    |
| 40    | 2000       | 0.0007   |            | 0.0007               |                         |           |        |

EUT is PASSED if:

- all Average values of the Individual Harmonic Currents (I<sub>avg</sub>) are below 100% of the Individual Limits.
- all Maximum values of the Individual Harmonic Currents (I<sub>max</sub>) are below 150% of the Individual Limits.

Test engineer:     Sun. Zhang



#### 6.4. Test Photographs





## 7. Voltage Fluctuations Test

### 7.1. Test Procedure

The equipment shall be tested under the conditions of **Clause 5**.

The total impedance of the test circuit, excluding the appliance under test, but including the internal impedance of the supply source, shall be equal to the reference impedance.

The stability and tolerance of the reference impedance shall be adequate to ensure that the overall accuracy of  $\pm 8\%$  is achieved during the whole assessment procedure.

### 7.2. Measurement Equipment

| Instrument/Ancillary           | Manufacturer      | Model No.      | Serial No. | Calibration Date | Valid Date. |
|--------------------------------|-------------------|----------------|------------|------------------|-------------|
| EMC Emission Tester            | EMCPARTNER        | Harmonics-1000 | 159        | 2016.03.26       | 2017.03.25  |
| Temperature/<br>Humidity Meter | Zhicheng          | ZC1-11         | CEP-TH-004 | 2016.03.29       | 2017.03.28  |
| HARCS                          | EMC Partner<br>AG | Ver 4.18       | N/A        | N/A              | N/A         |



### 7.3. Test Result and Data

|                      |   |              |
|----------------------|---|--------------|
| Basic Standard       | : | EN 61000-3-3 |
| Final Test Result    | : | PASS         |
| Test Mode            | : | Mode 1,5,8   |
| Model No.            | : | 238LM00023   |
| Temperature          | : | 22°C         |
| Humidity             | : | 56%          |
| Atmospheric Pressure | : | 100 kPa      |
| Test Date            | : | Mar 22, 2017 |

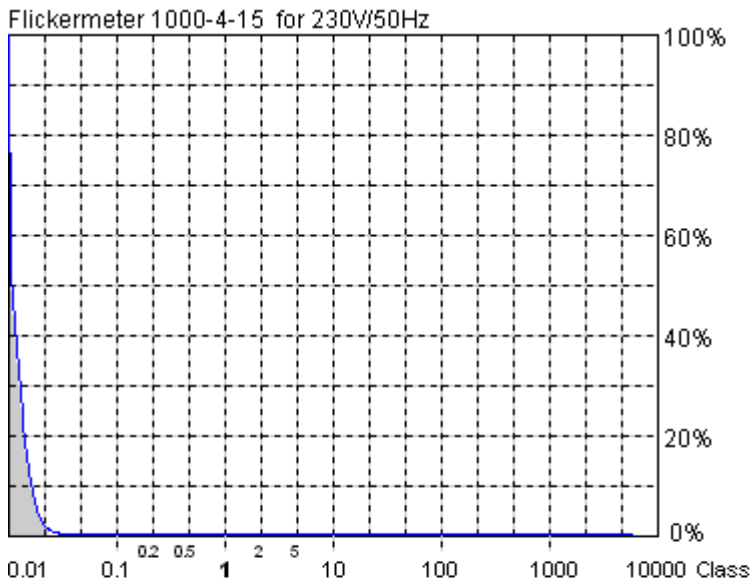

|   |               |
|---|---------------|
| <b>Actual Flicker (Fli):</b>                      | <b>0.01</b>   |
| <b>Short-term Flicker (Pst):</b>                  | <b>0.09</b>   |
| Limit (Pst):                                      | 1.00          |
| <b>Long-term Flicker (Plt):</b>                   | <b>0.09</b>   |
| Limit (Plt):                                      | 0.65          |
| <b>Maximum Relative Volt. Change (dmax):</b>      | <b>0.00%</b>  |
| Limit (dmax):                                     | 4.00%         |
| <b>Relative Steady-state Voltage Change (dc):</b> | <b>0.13%</b>  |
| Limit (dc):                                       | 3.30%         |
| <b>Maximum Interval exceeding 3.30% (dt):</b>     | <b>0.00ms</b> |
| Limit (dt>Lim):                                   | 500ms         |

**Flicker Emission - IEC 61000-3-3 , EN 61000-3-3 , (EN60555-3)**

Urms = 229.9 V    P = 19.63 W  
 Irms = 0.161 A    pf = 0.532

2017-3-22 9:35:13 harmonic.hsu

Range: 1 A  
 V-nom: 230 V  
 TestTime: 10 min (100%)

**Test completed, Result: PASSED**

HAR-1000 EMC-Parber

- Full Bar : Actual Values
- Empty Bar : Maximum Values
- Circles : Average Values
- Blue : Current , Green : Voltage , Red : Failed



Urms = 229.9V Freq = 50.000 Range: 1 A  
Irms = 0.161A Ipk = 0.566A cf = 3.526  
P = 19.63W S = 36.93VA pf = 0.532

Test - Time : 1 x 10min = 10min ( 100 %)

LIN (Line Impedance Network) : No LIN

Limits : Plt : 0.65 Pst : 1.00  
dmax : 4.00 % dc : 3.30 %  
dtLim: 3.30 % dt>Lim: 500ms

Test completed, Result: PASSED

Test engineer: Sun. Zhang





#### 7.4. Test Photographs





## 8. Electrostatic Discharge Immunity Test

### 8.1. Test Procedure

- a. In the case of air discharge testing the climatic conditions shall be within the following ranges:
  - ambient temperature: 15°C to 35°C;
  - relative humidity : 30% to 60%;
  - atmospheric pressure : 86 KPa (860 mbar) to 106 KPa (1060 mbar).
- b. Test programs and software shall be chosen so as to exercise all normal modes of operation of the EUT. The use of special exercising software is encouraged, but permitted only where it can be shown that the EUT is being comprehensively exercised.
- c. The test voltage shall be increased from the minimum to the selected test severity level, in order to determine any threshold of failure. The final severity level should not exceed the product specification value in order to avoid damage to the equipment.
- d. The test shall be performed with both air discharge and contact discharge. On reselected points at least 10 single discharges (in the most sensitive polarity) shall be applied on air discharge. On reselected points at least 25 single discharges (in the most sensitive polarity) shall be applied on contact discharge.
- e. For the time interval between successive single discharges an initial value of one second is recommended. Longer intervals may be necessary to determine whether a system failure has occurred.
- f. In the case of contact discharges, the tip of the discharge electrode shall touch the EUT before the discharge switch is operated.
- g. In the case of painted surface covering a conducting substrate, the following procedure shall be adopted :
  - If the coating is not declared to be an insulating coating by the equipment manufacturer, then the pointed tip of the generator shall penetrate the coating so as to make contact with the conducting substrate.
  - Coating declared as insulating by the manufacturer shall only be submitted to the air discharge.
  - The contact discharge test shall not be applied to such surfaces.
- h. In the case of air discharges, the round discharge tip of the discharge electrode shall be approached as fast as possible (without causing mechanical damage) to touch the EUT . After each discharge, the ESD generator (discharge electrode) shall be removed from the EUT. The generator is then retriggered for a new single discharge. This procedure shall be repeated until the discharges are completed. In the case of an air discharge test, the discharge switch, which is used for contact discharge, shall be closed.

## 8.2. Test Setup for Tests Performed in Laboratory

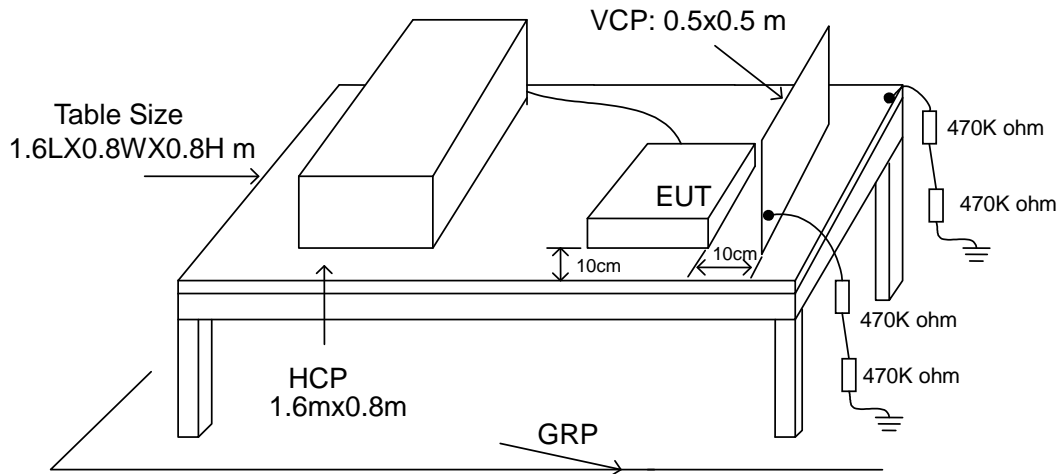

The test setup consists of the test generator, EUT and auxiliary instrumentation necessary to perform DIRECT and INDIRECT application of discharges to the EUT as applicable, in the follow manner :

- a. Contact Discharge to the conductive surfaces and to coupling plane;
- b. Air Discharge at insulating surfaces.

The preferred test method is that of type tests performed in laboratories and the only accepted method of demonstrating conformance with this standard. The EUT was arranged as closely as possible to arrangement in final installed conditions.

A ground reference plane was provided on the floor of the test site. It was a metallic sheet (copper or aluminum) of 0.25 mm, minimum thickness; other metallic may be used but they shall have at least 0.65 mm thickness. In the CerpPASS Technology Corp., we provided 1 mm thickness stainless steel ground reference plane. The minimum size of the ground reference plane is 2.5 m x 2.5 m, the exact size depending on the dimensions of the EUT. It was connected to the protective grounding system.

The EUT was arranged and connected according to its functional requirements. A distance of 1m minimum was provided between the EUT and the wall of the lab. and any other metallic structure. In cases where this length exceeds the length necessary to apply the discharges to the selected points, the excess length shall, where possible, be placed non-inductively off the ground reference plane and shall not come closer than 0.2m to other conductive parts in the test setup.

Where the EUT is installed on a metal table, the table was connected to the reference plane via a cable with a 470k ohm resistor located at each end, to prevent a build-up of charge. The test setup was consist a wooden table, 0.8m high, standing on the ground reference plane. A HCP, 1.6 m x 0.8 m, was placed on the table. The EUT and cables was isolated from the HCP by an insulating support 0.5 mm thick. The VCP size, 0.5 m x 0.5 m.



### 8.3. Test Severity Levels

| Contact Discharge |  | Air Discharge |                                    |
|-------------------|--|---------------|------------------------------------|
| Level             | Test Voltage (KV) of Contact discharge | Level         | Test Voltage (KV) of Air Discharge |
| 1                 | ±2                                     | 1             | ±2                                 |
| 2                 | ±4                                     | 2             | ±4                                 |
| 3                 | ±6                                     | 3             | ±8                                 |
| 4                 | ±8                                     | 4             | ±15                                |
| X                 | Specified                              | X             | Specified                          |

Remark: "X" is an open level.

### 8.4. Measurement Equipment

| Instrument/Ancillary           | Manufacturer    | Model No.  | Serial No.          | Calibration Date | Valid Date. |
|--------------------------------|-----------------|------------|---------------------|------------------|-------------|
| ESD Simulator                  | EM Test         | dito       | V0714102399         | 2016.04.21       | 2017.04.20  |
| Tonometer                      | shanghaifengyun | DYM3       | 3251                | 2016.12.21       | 2017.12.20  |
| Dehumidifier                   | ZEDO            | ZD-220LB   | CEP-TH-01           | N/A              | N/A         |
| Humidifier                     | YADU            | YZ-DS251C  | CEP-TH-02           | N/A              | N/A         |
| Temperature/<br>Humidity Meter | feiyang         | N/A        | 102                 | 2016.03.29       | 2017.03.28  |
| ESD Simulator                  | NoiseKen        | ESS-B3011A | AEC00315-00<br>C-0A | 2016.12.12       | 2017.12.11  |



8.5. Test Result and Data

Final Test Result : **PASS**  
 Pass performance criteria : B  
 Basic Standard : IEC 61000-4-2  
 Model No. : 238LM00023  
 Test Voltage : ±2 / ±4 / ±8 KV for air discharge,  
 ±2 / ±4 KV for contact discharge  
 Temperature : 22 °C  
 Relative Humidity : 49 %  
 Atmospheric Pressure : 100 kPa  
 Test Date : Mar 22, 2017

Test Mode : Mode 1,5,8

|              | Contact Discharge |     |      |     |      |     |      |     | Air Discharge   |     |      |     |      |     |       |     |
|--------------|-------------------|-----|------|-----|------|-----|------|-----|-----------------|-----|------|-----|------|-----|-------|-----|
|              | 25 times / each   |     |      |     |      |     |      |     | 10 times / each |     |      |     |      |     |       |     |
| Voltage      | 2 kV              |     | 4 kV |     | 6 kV |     | 8 kV |     | 2 kV            |     | 4 kV |     | 8 kV |     | 10 kV |     |
| HCP          | A                 | A   | A    | A   | ---  | --- | ---  | --- | ---             | --- | ---  | --- | ---  | --- | ---   | --- |
| VCP          | A                 | A   | A    | A   | ---  | --- | ---  | --- | ---             | --- | ---  | --- | ---  | --- | ---   | --- |
| Screw        | A                 | A   | A    | A   | ---  | --- | ---  | --- | ---             | --- | ---  | --- | ---  | --- | ---   | --- |
| Case         | ---               | --- | ---  | --- | ---  | --- | ---  | --- | A               | A   | A    | A   | A    | A   | ---   | --- |
| Panel        | ---               | --- | ---  | --- | ---  | --- | ---  | --- | A               | A   | A    | A   | A    | A   | ---   | --- |
| VGA Port     | A                 | A   | A    | A   | ---  | --- | ---  | --- | A               | A   | A    | A   | A    | A   | ---   | --- |
| Display Port | A                 | A   | A    | A   | ---  | --- | ---  | --- | A               | A   | A    | A   | A    | A   | ---   | --- |
| HDMI Port    | A                 | A   | A    | A   | ---  | --- | ---  | --- | A               | A   | A    | A   | A    | A   | ---   | --- |
| Audio Port   | ---               | --- | ---  | --- | ---  | --- | ---  | --- | A               | A   | A    | A   | A    | A   | ---   | --- |
| Power Port   | ---               | --- | ---  | --- | ---  | --- | ---  | --- | A               | A   | A    | A   | A    | A   | ---   | --- |
| Button       | ---               | --- | ---  | --- | ---  | --- | ---  | --- | A               | A   | A    | A   | A    | A   | ---   | --- |
| LED Light    | ---               | --- | ---  | --- | ---  | --- | ---  | --- | A               | A   | A    | A   | A    | A   | ---   | --- |

Test engineer: Sun. Zhang



### 8.6. Test Photographs





## 9. Radio Frequency electromagnetic field immunity test

### 9.1. Test Procedure

- a. The equipment to be tested is placed in the center of the enclosure on a wooden table. The equipment is then connected to power and signal leads according to pertinent installation instructions.
- b. The antenna which is enabling the complete frequency range of 80-1000 MHz is placed 3m away from the equipment. The required field strength is determined by placing the field strength meter(s) on top of or directly alongside the equipment under test and monitoring the field strength meter via a remote field strength indicator outside the enclosure while adjusting the continuous-wave to the applicable antennae.
- c. The test is normally performed with the antenna facing the most sensitive side of the EUT. The polarization of the field generated by the bucolical antenna necessitates testing each position twice, once with the antenna positioned vertically and again with the antenna positioned horizontally. The circular polarization of the field from the log-spiral antenna makes a change of position of the antenna unnecessary.
- d. At each of the above conditions, the frequency range is swept 80-1000 MHz, pausing to adjust the R.F. signal level or to switch oscillators and antenna. The rate of sweep is in the order of  $1.5 \times 10^{-3}$  decades/s. The sensitive frequencies or frequencies of dominant interest may be discretely analyzed.

### 9.2. Test Severity Levels

| Frequency Band : 80-1000 MHz  |                           |
|-------------------------------|---------------------------|
| Level                         | Test field strength (V/m) |
| 1                             | 1                         |
| 2                             | 3                         |
| 3                             | 10                        |
| X                             | Specified                 |
| Remark: "X" is an open class. |                           |

### 9.3. TEST SETUP

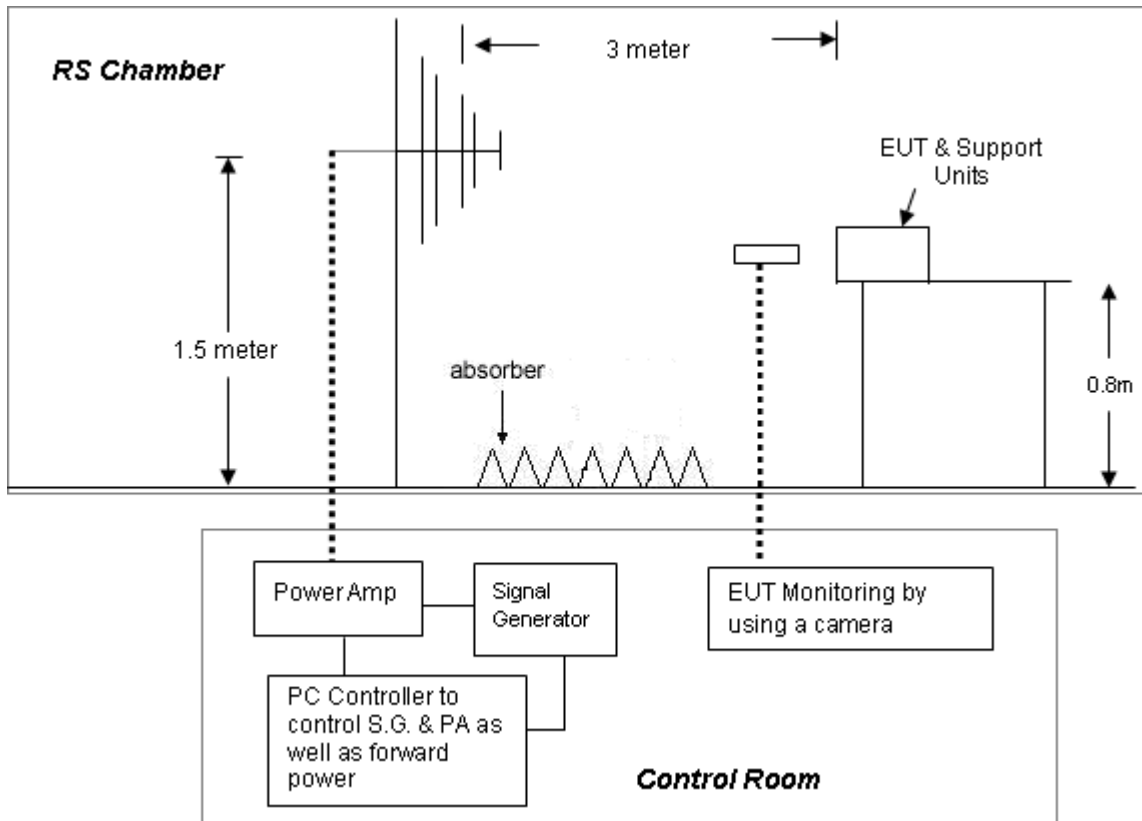

- For the actual test configuration, please refer to the related item – Photographs of the Test Configuration.

#### NOTE:

##### TABLETOP EQUIPMENT

The EUT installed in a representative system as described in section 7 of IEC 61000-4-3 was placed on a non-conductive table 0.8 meters in height. The system under test was connected to the power and signal wire according to relevant installation instructions.

##### FLOOR STANDING EQUIPMENT

The EUT installed in a representative system as described in section 7 of IEC 61000-4-3 was placed on a non-conductive wood support 0.1 meters in height. The system under test was connected to the power and signal wire according to relevant installation instructions.





#### 9.4. Measurement Equipment

| Instrument/Ancillary           | Manufacturer  | Model No.                | Serial No. | Calibration Date | Valid Date. |
|--------------------------------|---------------|--------------------------|------------|------------------|-------------|
| Signal Generator               | R&S           | SML03                    | 103287     | 2016.03.26       | 2017.03.25  |
| Power Sensor                   | R&S           | NR P-Z91                 | 100383     | 2016.03.26       | 2017.03.25  |
| Power Sensor                   | R&S           | NRP-Z91                  | 100384     | 2016.03.26       | 2017.03.25  |
| Power Meter                    | R&S           | NRP                      | 101206     | 2016.03.26       | 2017.03.25  |
| Power Amplifier                | BONN          | BLWA0830-16<br>0/100/40D | 076659     | 2016.03.26       | 2017.03.25  |
| Istropic Electric Field Probe  | EST.LINDGREN  | HI-6105                  | 137445     | 2016.11.20       | 2017.11.19  |
| EMS Antenna                    | R&S           | HL046E                   | 100028     | N/A              | N/A         |
| Temperature/<br>Humidity Meter | feiyang       | N/A                      | 101        | 2016.03.29       | 2017.03.28  |
| EMC-32                         | Rohde&Schwarz | Ver 6.10.0               | N/A        | N/A              | N/A         |



9.5. Test Result and Data

Final Test Result : **PASS**  
 Pass performance criteria : A  
 Basic Standard : IEC 61000-4-3  
 Model No. : 238LM00023  
 Frequency Range : 80~1000 MHz  
 Temperature : 22°C  
 Relative Humidity : 53%  
 Atmospheric Pressure : 100 kPa  
 Test Date : Mar 22, 2017

Test Mode: Mode 1,5,8

| Modulation : AM 80% , 1KHz sine wave , Dwell time: 3.0 S |                      |       |                      |        |
|--|----------------------|-------|----------------------|--------|
| Frequency Step Size : 1 % of preceding frequency value   |                      |       |                      |        |
| Frequency (MHz)  | Antenna Polarization | face  | Field strength (V/m) | Result |
| 80~1000  | Vertical             | Front | 3 V/m                | A      |
| 80~1000  | Vertical             | Rear  | 3 V/m                | A      |
| 80~1000  | Vertical             | Left  | 3 V/m                | A      |
| 80~1000  | Vertical             | Right | 3 V/m                | A      |
| 80~1000  | Horizontal           | Front | 3 V/m                | A      |
| 80~1000  | Horizontal           | Rear  | 3 V/m                | A      |
| 80~1000  | Horizontal           | Left  | 3 V/m                | A      |
| 80~1000  | Horizontal           | Right | 3 V/m                | A      |

Test engineer: Sun. Zhang



### 9.6. Test Photographs





## 10. Electrical Fast Transient/ Burst Immunity Test

### 10.1. Test Procedure

- a. In order to minimize the effect of environmental parameters on test results, the climatic conditions when test is carrying out shall comply with the following requirements:
  - ambient temperature: 15°C to 35°C;
  - relative humidity : 45% to 75%;
  - Atmospheric pressure: 86 Kpa (860 mbar) to 106 Kpa (1060 mbar).
- b. In order to minimize the effect of environmental parameters on test results, the electromagnetic environment of the laboratory shall not influence the test results.
- c. The variety and diversity of equipment and systems to be tested make it difficult to establish general criteria for the evaluation of the effects of fast transients/bursts on equipment and systems.
- d. Test on Power Line:
  - The EFT/B-generator was located on the GRP.  
For floor standing equipment 1,0 m  
For table top equipment 0,5 m
  - The EFT/B-generator provides the ability to apply the test voltage in a non-symmetrical condition to the power supply input terminals of the EUT.
- e. Test on Communication Lines
  - The coupling clamp is composed of a clamp unit for housing the cable (length more than 3 m), and was placed on the GRP.
  - The coupling clamp provides the ability of coupling the fast transient/bursts to the cable under test.
- f. The test results may be classified on the basic of the operating conditions and the functional specification of the equipment under test, according to the following performance criteria :
  - Normal performance within the specification limits.
  - Temporary degradation or loss of function or performance which is self-recoverable.
  - Temporary degradation or loss of function or performance which requires operator intervention or system reset.
  - Degradation or loss of function which is not recoverable due to damage of equipment (components).

### 10.2. Test Severity Levels

The following test severity levels are recommended for the fast transient/burst test :

| Open circuit output test voltage $\pm 10\%$ |                 |                                      |
|---|-----------------|--------------------------------------|
| Level                                       | On Power Supply | On I/O signal, data and control line |
| 1   | 0.5 KV          | 0.25 KV                              |
| 2   | 1.0 KV          | 0.50 KV                              |
| 3   | 2.0 KV          | 1.00 KV                              |
| 4   | 4.0 KV          | 2.00 KV                              |
| X   | Specified       | Specified                            |

Remark : “ X ” is an open level. The level is subject to negotiation between the user and manufacturer or is specified by the manufacturer.

### 10.3. TEST SETUP

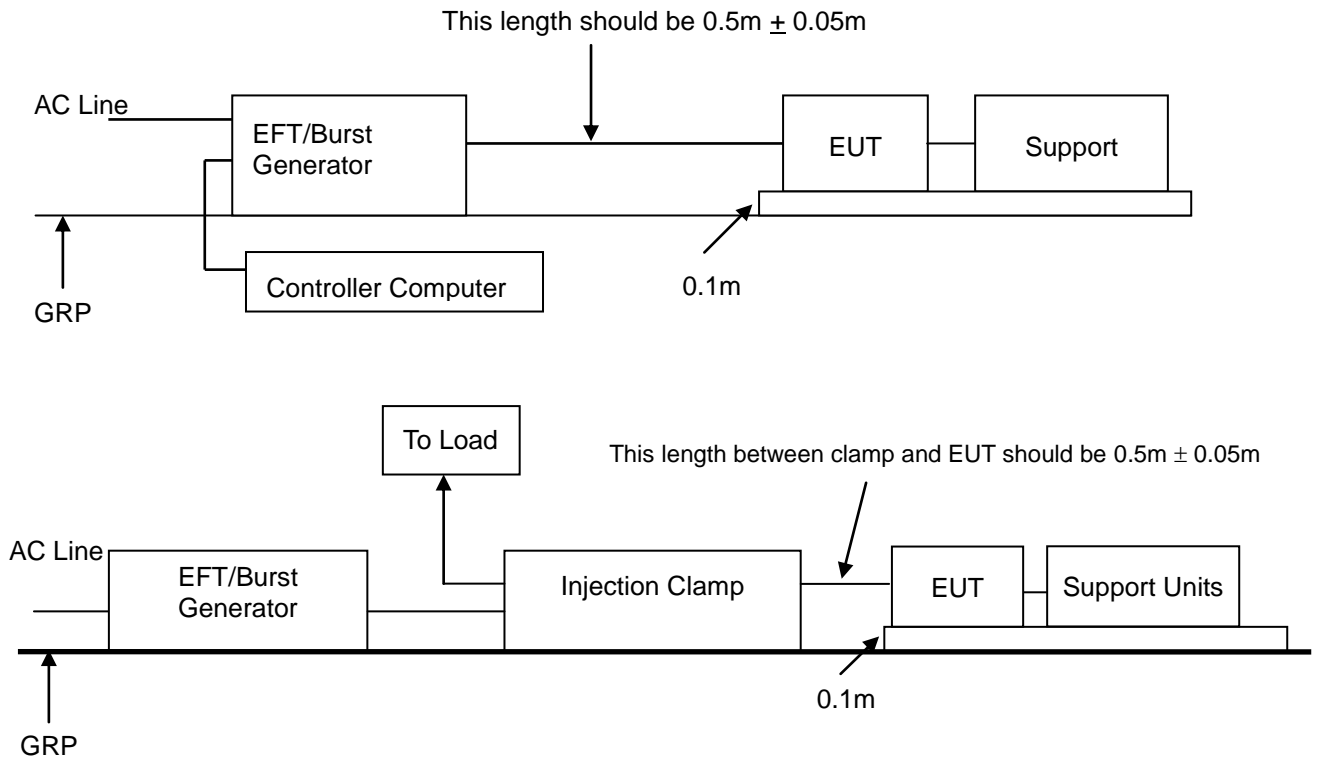

- For the actual test configuration, please refer to the related item – Photographs of the Test Configuration.

**NOTE:**

**TABLETOP EQUIPMENT**

The configuration consisted of a wooden table (0.1m high) standing on the Ground Reference Plane. The GRP consisted of a sheet of aluminum (at least 0.25mm thick and 2.5m square) connected to the protective grounding system. A minimum distance of 0.5m was provided between the EUT and the walls of the laboratory or any other metallic structure.

**FLOOR STANDING EQUIPMENT**

The EUT installed in a representative system as described in section 7 of IEC 61000-4-4 and its cables, were isolated from the Ground Reference Plane by an insulating support that is 0.1-meter thick. The GRP consisted of a sheet of aluminum (at least 0.25mm thick and 2.5m square) connected to the protective grounding system.

### 10.4. Measurement Equipment

| Instrument/Ancillary        | Manufacturer | Model No.     | Serial No. | Calibration Date | Valid Date. |
|-----------------------------|--------------|---------------|------------|------------------|-------------|
| TRANSIENT                   | EMCPARTNER   | TRA2000IN6    | 901        | 2016.06.26       | 2017.06.25  |
| CDN                         | EMCPARTNER   | CDN2000-06-32 | 121        | 2016.03.26       | 2017.03.25  |
| Coupling clamp              | EMCPARTNER   | CN-EFT1000    | 547        | 2016.03.26       | 2017.03.25  |
| Temperature/ Humidity Meter | Zhicheng     | ZC1-11        | CEP-TH-005 | 2016.03.29       | 2017.03.28  |



### 10.5. Test Result and Data

Final Test Result : **PASS**  
 Pass performance criteria : B  
 Basic Standard : IEC 61000-4-4  
 Model No. : 238LM00023  
 Test Voltage : On Power Supply -- ±1.0 kV  
 : On I/O signal, data and control line -- ±0.5 kV  
 Temperature : 23° C  
 Relative Humidity : 54 %  
 Atmospheric Pressure : 100 kPa  
 Test Date : Mar 23, 2017

Test Mode: Mode 1,5,8

| Pulse : 5/50 ns                        |        | Repetition Rate: 5 kHz           |     |               |   |
|--|--------|----------------------------------|-----|---------------|---|
| Burst : 15m/300ms                      |        | Test time : 1 min/each condition |     |               |   |
| Voltage/ Mode/ Polarity/ Result/ Phase |        | <u>0.5 kV</u>                    |     | <u>1.0 kV</u> |   |
|  |        | +                                | —   | +             | — |
| Power Line                             | L      | ---                              | --- | A             | A |
|  | N      | ---                              | --- | A             | A |
|  | L-N    | ---                              | --- | A             | A |
|  | PE     | ---                              | --- | A             | A |
|  | L-PE   | ---                              | --- | A             | A |
|  | N-PE   | ---                              | --- | A             | A |
|  | L-N-PE | ---                              | --- | A             | A |

Test engineer: Sun. Zhang



## 10.6. Test Photographs





## 11. Surge Immunity Test

### 11.1. Test Procedure

- a. Climatic conditions  
The climatic conditions shall comply with the following requirements :
  - ambient temperature : 15 °C to 35 °C
  - relative humidity : 10 % to 75 %
  - atmospheric pressure : 86 kPa to 106 kPa ( 860 mbar to 1060 mbar )
- b. Electromagnetic conditions  
the electromagnetic environment of the laboratory shall not influence the test results.
- c. The test shall be performed according the test plan that shall specify the test set-up with
  - generator and other equipment utilized;
  - test level ( voltage/current );
  - generator source impedance;
  - internal or external generator trigger;
  - number of tests : at least five positive and five negative at the selected points;
  - repetition rate : maximum 1/min.
  - inputs and outputs to be tested;
  - representative operating conditions of the EUT;
  - sequence of application of the surge to the circuit;
  - phase angle in the case of AC. power supply;
  - actual installation conditions, for example :
    - AC : neutral earthed,
    - DC : ( + ) or ( - ) earthed to simulated the actual earthing conditions.
- d. If not otherwise specified the surges have to be applied synchronized to the voltage phase at the zero-crossing and the peak value of the AC. voltage wave ( positive and negative ).
- e. The surges have to be applied line to line and line(s) and earth. When testing line to earth, the test voltage has to be applied successively between each of the lines and earth, if there is no other specification.
- f. The test procedure shall also consider the non-linear current-voltage characteristics of the equipment under test. Therefore the test voltage has to be increased by steps up to the test level specified in the product standard or test plan.
- g. All lower levels including the selected test level shall be satisfied. For testing the secondary protection, the output voltage of the generator shall be increased up to the worst-case voltage breakdown level ( let-through level ) of the primary protection.
- h. If the actual operating signal sources are not available, that may be simulated. Under no circumstances may the test level exceed the product specification. The test shall be carried out according to a test plan.
- i. To find all critical points of the duty cycle of the equipment, a sufficient number of positive and negative test pulses shall be applied. For acceptance test previously unstressed equipment shall be used to the protection devices shall be replaced.

### 11.2. Test Severity Level

| Level   | Open-circuit test voltage, $\pm 10\%$ , KV |
|---|--|
| 1   | 0.5  |
| 2   | 1.0  |
| 3   | 2.0  |
| 4   | 4.0  |
| X   | Specified                                  |
| NOTE: "X" is an open class. This level can be specified in the product specification. |  |





### 11.3. TEST SETUP

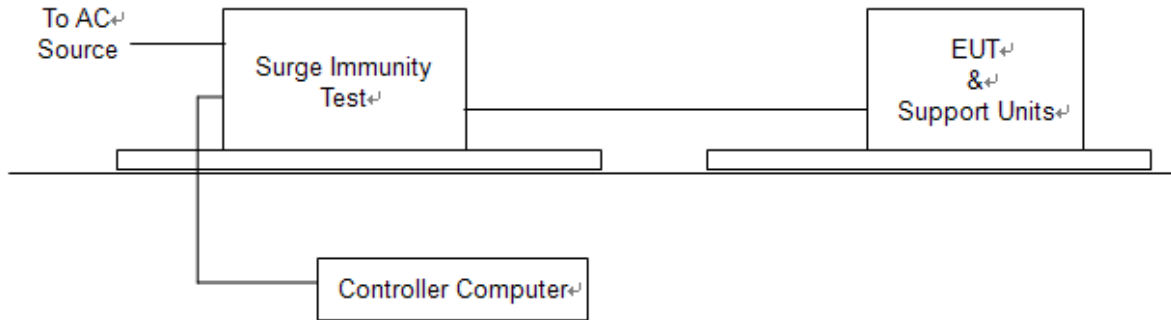

For the actual test configuration, please refer to the related item – Photographs of the Test Configuration.

### 11.4. Measurement Equipment

| Instrument/Ancillary           | Manufacturer | Model No. | Serial No.      | Calibration Date | Valid Date. |
|--------------------------------|--------------|-----------|-----------------|------------------|-------------|
| TRANSIENT                      | TESEQ        | NSG 3060  | 1830            | 2017.02.04       | 2018.02.03  |
| CDN                            | TESEQ        | CDN 3061  | 1575            | 2017.02.04       | 2018.02.03  |
| CDN                            | TESEQ        | CNV508T5  | P<br>1546167499 | 2017.02.17       | 2018.02.16  |
| CDN                            | TESEQ        | CDN HSS-2 | 41020           | 2017.02.24       | 2018.02.23  |
| Temperature/<br>Humidity Meter | Zhicheng     | ZC1-11    | CEP-TH-005      | 2016.03.29       | 2017.03.28  |



11.5. Test Result and Data

Final Test Result : **PASS**  
 Pass performance criteria : B  
 Basic Standard : IEC 61000-4-5  
 Model No. : 238LM00023  
 Test Voltage : Input AC Power Port -- ±0.5/1.0 kV for Line to Line  
 ±0.5/1.0/2.0 kV for Line to Ground  
 Temperature : 23°C  
 Relative Humidity : 54 %  
 Atmospheric Pressure : 100 kPa  
 Test Date : Mar 23, 2017

Test Mode: Mode 1,5,8

Waveform : 1.2/50µs(8/20µs)    Repetition rate : 60 sec    Time : 20 time/each condition

| /Phase Voltage / Mode / Polarity / Result |      |   | 0° | 90° | 180° | 270° |
|---|------|---|----|-----|------|------|
| 0.5/1.0 kV                                | L-N  | + | A  | A   | A    | A    |
|   |      | - | A  | A   | A    | A    |
| 0.5/1.0/2.0kV                             | L-PE | + | A  | A   | A    | A    |
|   |      | - | A  | A   | A    | A    |
|   | N-PE | + | A  | A   | A    | A    |
|   |      | - | A  | A   | A    | A    |

Test engineer: Sun. Zhang



### 11.6. Test Photographs





## 12. Conduction Disturbances induced by Radio-Frequency Fields

### 12.1. Test Procedure

- a. The EUT shall be operated within its intended climatic conditions. The temperature and relative humidity should be recorded.
- b. This test method test can be performed without using a sell shielded enclosure. This is because the disturbance levels applied and the geometry of the setups are not likely to radiated a high amount of energy, especially at the lower frequencies. If under certain circumstances the radiated energy is too high, a shielded enclosure has to be used.
- c. The test shall be performed with the test generator connected to each of the coupling and decoupling devices in turn while the other non-excited RF-input ports of the coupling devices are terminated by a 50 ohm load resistor.
- d. The frequency range is swept from 150 KHz to 80 MHz, using the signal levels established during the setting process, and with the disturbance signal 80% amplitude modulated with a 1KHz sign wave, pausing to adjust the RF-signal level or to switch coupling devices as necessary. The rate of sweep shall no exceed  $1.5 \times 10^{-3}$  decades/s. Where the frequency is swept incrementally, the step size shall no exceed 1% of the start and thereafter 1% of the preceding frequency value.
- e. The dwell time at each frequency shall not be less than the time necessary for the EUT to be exercised, and able to respond. Sensitive frequencies e.g. clock frequency (ies) and harmonics or frequencies of dominant interest shall be analyzed separately.
- f. An alternative test procedure may be adopted, wherein the frequency range is swept incrementally, with a step size not exceeding 4% of the start ad thereafter 4% of the preceding frequency value. The test level should be at least twice the value of the specified test level.
- g. In cases of dispute, the test procedure using a step size not exceeding 1% of the start and thereafter 1% of preceding frequency value shall take precedence.
- h. Attempts should be made to fully exercise the EUT during testing, and to fully interrogate all exercise modes selected for susceptibility.
- i. The use of special exercising programs is recommended.
- j. Testing shall be performed according to a Test Plan, which shall be included in the test report.
- k. It may be necessary to carry out some investigatory testing in order to establish some aspects of the test plan.

### 12.2. Test Severity Levels

| Level  | Voltage Level ( e.m.f. ) |
|--|--------------------------|
| 1  | 1 V                      |
| 2  | 3 V                      |
| 3  | 10 V                     |
| x  | Specified                |
| NOTE - x is an open class. This level can be specified in the product specification. |                          |

### 12.3. TEST SETUP

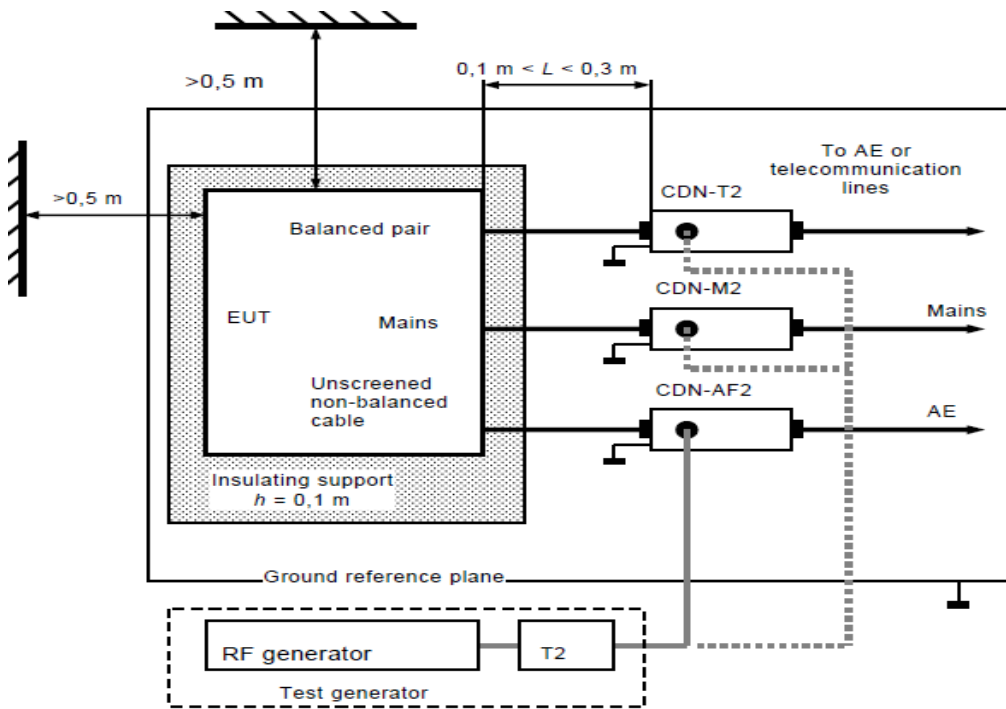

- Note:**
1. The EUT is setup 0.1m above Ground Reference Plane
  2. The CDNs and / or EM clamp used for real test depends on ports and cables configuration of EUT.
  3. For the actual test configuration, please refer to the related item – Photographs of the Test Configuration.

### 12.4. Measurement Equipment

| Instrument/Ancillary           | Manufacturer | Model No.   | Serial No. | Calibration Date | Valid Date. |
|--------------------------------|--------------|-------------|------------|------------------|-------------|
| Conducted immunity test system | FRANKONIA    | CIT-10/75   | 102D1294   | 2016.03.26       | 2017.03.25  |
| EM Injection clamp             | FCC          | F-203I-23MM | 536        | 2016.03.26       | 2017.03.25  |
| CDN                            | FRANKONIA    | CDN-T2      | A3010029   | 2016.03.26       | 2017.03.25  |
| CDN                            | FRANKONIA    | CDN-T4      | A3015017   | 2016.03.26       | 2017.03.25  |
| CDN                            | FRANKONIA    | CDN-T8      | A3022010   | 2016.03.26       | 2017.03.25  |
| CDN                            | FRANKONIA    | CDN-M2      | A3002037   | 2016.03.26       | 2017.03.25  |
| CDN                            | FRANKONIA    | CDN-M2+M3   | A3011102   | 2016.03.26       | 2017.03.25  |
| CDN                            | FCC          | CDN-M5/32   | A3013024   | 2016.03.26       | 2017.03.25  |
| 6 dB Attenuator                | FRANKONIA    | N/A         | N/A        | 2016.03.26       | 2017.03.25  |
| Temperature/ Humidity Meter    | Zhicheng     | ZC1-11      | CEP-TH-005 | 2016.04.02       | 2017.04.01  |
| EN61000-4-6                    | Hubert GmbH  | Ver 2.21    | N/A        | N/A              | N/A         |



12.5. Test Result and Data

Final Test Result : **PASS**  
 Pass performance criteria : A  
 Basic Standard : IEC 61000-4-6  
 Model No. : 238LM00023  
   CDN-(M2+M3) for AC power ports  
 Coupling mode : CDN-T4 for signal ports  
   EM-Clamp for signal ports  
 Temperature : 23° C  
 Relative Humidity : 54 %  
 Atmospheric Pressure : 100 kPa  
 Test Date : Mar 23, 2017

Test Mode : Mode 1,5,8

Frequency : 0.15~80MHz, Modulation : AM 80%,1KHz sine wave, Dwell time:3.0s

Frequency Step Size : 1 % of preceding frequency value

| Frequency    | Test mode | Voltage(V) | Result |
|--------------|-----------|------------|--------|
| 0.15 ~ 80MHz | Power(M3) | 3          | A      |

Test engineer:           Sun. Zhang



## 12.6. Test Photographs



### 13. Power Frequency Magnetic Field Immunity Test

#### 13.1. Test Setup

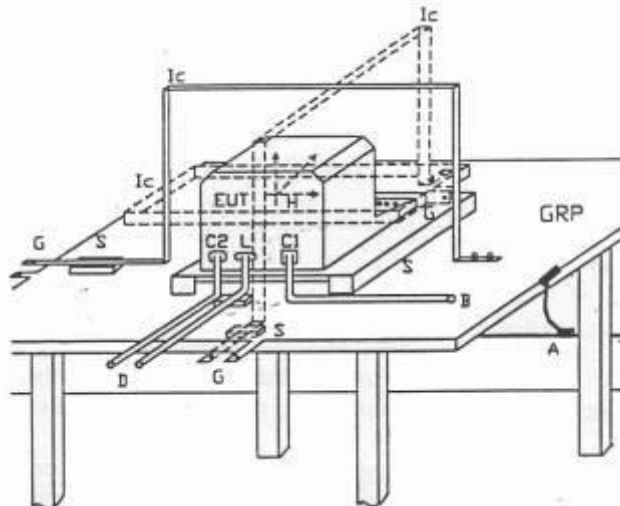

- GPR : Ground plane
- A : Safety earth
- S : Insulating support
- EUT : Equipment under test
- Lc : Induction coil
- E : Earth terminal
- C1 : Power supply circuit
- C2 : Signal circuit
- L : Communication line
- B : To power supply source
- D : To signal source, simulator
- G : To the test generator

#### 13.2. Test Severity Levels

| Level           | Magnetic field strength (A/m) |
|-----------------|-------------------------------|
| 1               | 1                             |
| 2               | 3                             |
| 3               | 10                            |
| 4               | 30                            |
| 5               | 100                           |
| X <sup>1)</sup> | special                       |

NOTE 1 "X" is an open level. This level can be given in the product specification.

#### 13.3. Measurement Equipment

| Instrument/Ancillary        | Manufacturer | Model No.  | Serial No. | Calibration Date | Valid Date. |
|-----------------------------|--------------|------------|------------|------------------|-------------|
| TRANSIENT                   | EMCPARTNER   | TRA2000IN6 | 901        | 2016.06.26       | 2017.06.25  |
| H-Filed-Loop                | EMCPARTNER   | MF1000-1   | 144        | 2016.03.26       | 2017.03.25  |
| Temperature/ Humidity Meter | Zhicheng     | ZC1-11     | CEP-TH-005 | 2016.03.29       | 2017.03.28  |





13.4. Test Result and Data

Final Test Result : **PASS**  
 Pass performance criteria : A  
 Basic Standard : IEC 61000-4-8  
 Model No. : 238LM00023  
 Temperature : 23 °C  
 Relative Humidity : 54 %  
 Atmospheric Pressure : 100 kPa  
 Test Date : Mar 23, 2017

Test Mode: Mode 1,5,8

| Power Frequency Magnetic Field : <u>50</u> Hz, <u>1</u> A/m |                  |         |
|---|------------------|---------|
| Coil Orientation  | Testing duration | Results |
| X-axis  | 1.0 Min          | A       |
| Y-axis  | 1.0 Min          | A       |
| Z-axis  | 1.0 Min          | A       |
| Power Frequency Magnetic Field : <u>60</u> Hz, <u>1</u> A/m |                  |         |
| Coil Orientation  | Testing duration | Results |
| X-axis  | 1.0 Min          | A       |
| Y-axis  | 1.0 Min          | A       |
| Z-axis  | 1.0 Min          | A       |

Test engineer: Sun. Zhang



### 13.5. Test Photographs



## 14. Voltage Dips and Voltage Interruptions Immunity Test Setup

### 14.1. Test Conditions

1. Source voltage and frequency : AC 100/230/240V / 50Hz, Single phase.
2. Test of interval : 10 sec.
3. Level and duration : Sequence of 3 dips/interrupts.
4. Voltage rise (and fall) time : 1 ~ 5  $\mu$ s.
5. Test severity :

| Voltage dips and Interrupt reduction (%) | Test Duration (period) |
|--|------------------------|
| >95%                                     | 250                    |
| 30%                                      | 25                     |
| >95%                                     | 0.5                    |

### 14.2. TEST SETUP

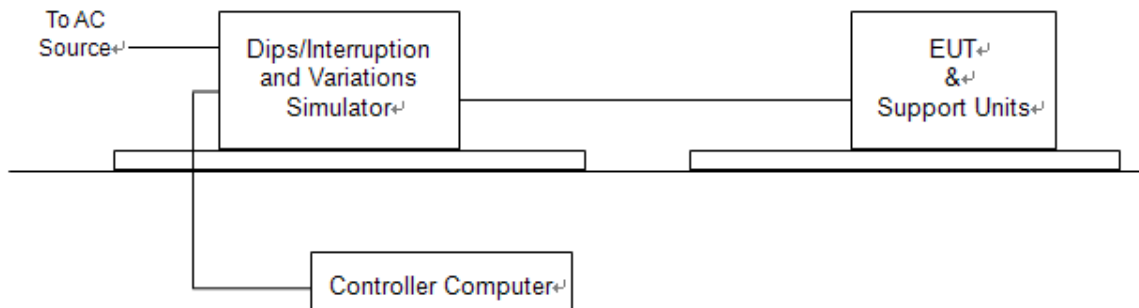

For the actual test configuration, please refer to the related item – Photographs of the Test Configuration.

### 14.3. Measurement Equipment

| Instrument/Ancillary        | Manufacturer | Model No.  | Serial No. | Calibration Date | Valid Date. |
|-----------------------------|--------------|------------|------------|------------------|-------------|
| TRANSIENT                   | EMCPARTNER   | TRA2000IN6 | 901        | 2016.06.26       | 2017.06.25  |
| Temperature/ Humidity Meter | Zhicheng     | ZC1-11     | CEP-TH-005 | 2016.03.29       | 2017.03.28  |



14.4. Test Result and Data

Final Test Result : **PASS**  
 Pass performance Criteria : C for voltage interruption, B for voltage dips  
 Basic Standard : IEC 61000-4-11  
 Model No. : 238LM00023  
 Temperature : 23°C  
 Relative Humidity : 54 %  
 Atmospheric Pressure : 100 kPa  
 Test Date : Mar 23, 2017

Test Mode: Mode 1,5,8

| Voltage(UT): AC 230 V/240V 50 Hz Interval(s) : 10s Times : 3 |                    |                             |                |    |    |     |     |     |     |     |
|--|--------------------|-----------------------------|----------------|----|----|-----|-----|-----|-----|-----|
| Test mod   | Test level<br>UT % | Durations<br>(period / ms ) | Phase / Result |    |    |     |     |     |     |     |
|  |                    |                             | 0              | 45 | 90 | 135 | 180 | 225 | 270 | 315 |
| Voltage interruptions  | >95%               | 250                         | C              | C  | C  | C   | C   | C   | C   | C   |
| Voltage dips   | 30%                | 25                          | A              | A  | A  | A   | A   | A   | A   | A   |
|  | >95%               | 0.5                         | A              | A  | A  | A   | A   | A   | A   | A   |

Test Mode: Mode 1,5,8

| Voltage(UT): AC 100 V 50 Hz Interval(s) : 10s Times : 3 |                    |                             |                |    |    |     |     |     |     |     |
|---|--------------------|-----------------------------|----------------|----|----|-----|-----|-----|-----|-----|
| Test mod  | Test level<br>UT % | Durations<br>(period / ms ) | Phase / Result |    |    |     |     |     |     |     |
|   |                    |                             | 0              | 45 | 90 | 135 | 180 | 225 | 270 | 315 |
| Voltage interruptions                                   | >95%               | 250                         | C              | C  | C  | C   | C   | C   | C   | C   |
| Voltage dips  | 30%                | 25                          | B              | B  | B  | B   | B   | B   | B   | B   |
|   | >95%               | 0.5                         | B              | B  | B  | B   | B   | B   | B   | B   |

Test engineer: Sun. Zhang



### 14.5. Test Photographs





## 15. Photographs of EUT

### 1) EUT Photo

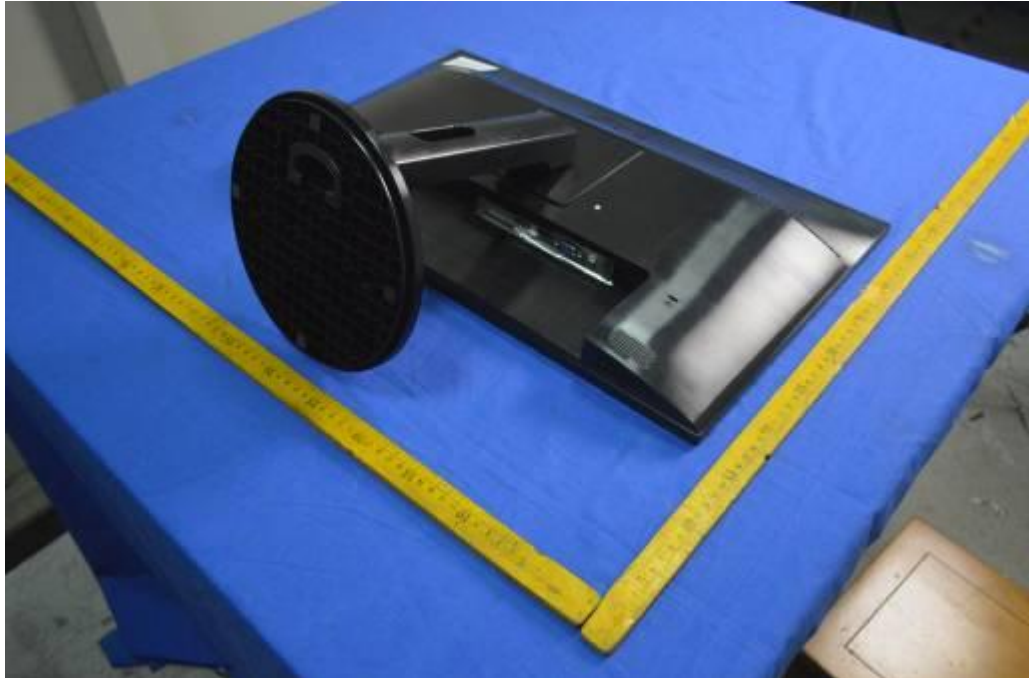

### 2) EUT Photo

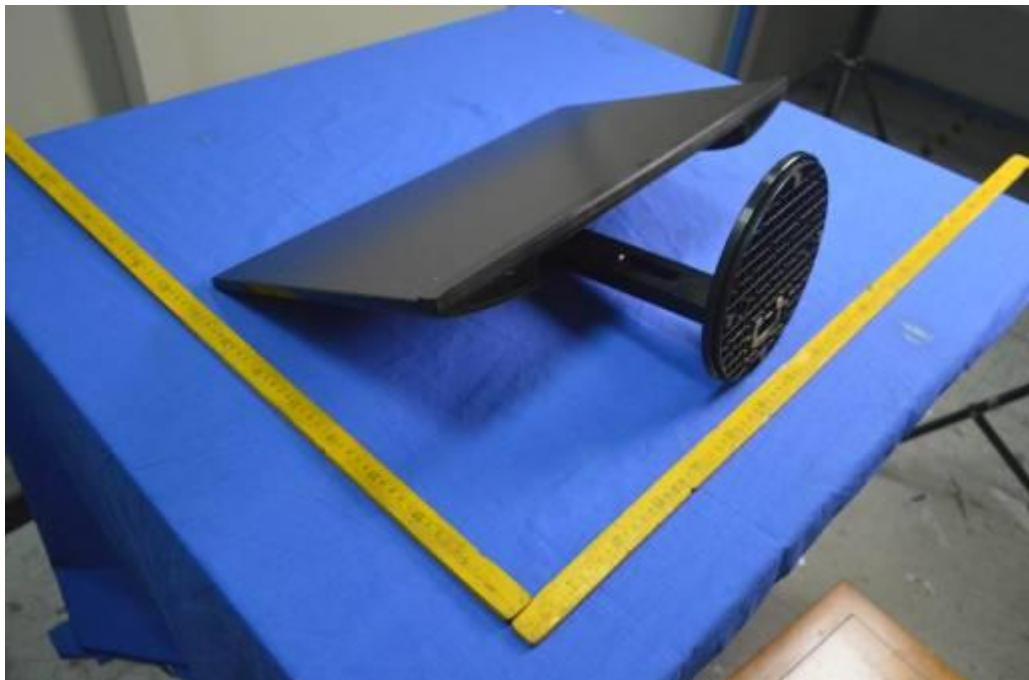



3) EUT Photo



4) EUT Photo





5) EUT Photo

