

TPV Electronics (Fujian) Co., Ltd.  
Mr. Xinliang Wu  
RD-SE  
Rongqiao Economic and  
Technological Development Zone  
Fuqing City, Fujian Province  
P.R. China

Date : 15.04.2016  
Our ref. : WangAn ZJ  
Your ref.: 1140025556

**Ref : CB Certificate Japan**

Type of Equipment : LCD Monitor  
Model Designation : See Certificate  
Certificate No. : JPTUV-071170  
Report No. : 17056170 001

Dear Mr. Xinliang Wu,

Thank you very much for your interest in our services.

Please find enclosed your certification documents.

We appreciate your support and would like to offer our assistance in the approval of your future products through our extensive range of technical services.

Please feel free to contact us whatever your requirements may be.

With kind regards,

Certification Body



Eng. M. Eichenseder

Enclosure

证书的详细资料请登陆[www.certipedia.com](http://www.certipedia.com)查阅,或拨打我司客服热线800 999 3668 / 400 883 1300咨询

IEC SYSTEM FOR MUTUAL RECOGNITION OF TEST  
CERTIFICATES FOR ELECTRICAL EQUIPMENT  
(IECEE) CB SCHEME

SYSTEME CEI D'ACCEPTATION MUTUELLE DE  
CERTIFICATS D ESSAIS DES EQUIPEMENTS  
ELECTRIQUES (IECEE) METHODE OC

## CB TEST CERTIFICATE

## CERTIFICAT D'ESSAI OC

Product  
Produit

LCD Monitor

Name and address of the applicant  
Nom et adresse du demandeur

TPV Electronics (Fujian) Co., Ltd.  
Rongqiao Economic and  
Technological Development Zone, Fuqing City, Fujian Province, P.R.  
China

Name and address of the manufacturer  
Nom et adresse du fabricant

TPV Electronics (Fujian) Co., Ltd.  
Rongqiao Economic and  
Technological Development Zone, Fuqing City, Fujian Province, P.R.  
China

Name and address of the factory  
Nom et adresse de l'usine

See additional page(s)

Ratings and principal characteristics  
Valeurs nominales et caractéristiques principales

DC 20V; 6A; Class III

Trademark (if any)  
Marque de fabrique (si elle existe)

AOC

Type of Manufacturer's Testing Laboratories used  
Type de programme du laboratoire d'essais constructeur

N/A

Model / Type Ref.  
Ref. de type

\*\*271\*\*\*\*\* , 270LM000\*\*  
(\* = 0-9, A-Z, a-z, +, -, \, / or blank)

Additional information (if necessary may also be  
reported on page 2)  
Les informations complémentaires (si nécessaire,  
peuvent être indiqués sur la 2<sup>ème</sup> page)

For model differences, refer to the test report.

A sample of the product was tested and found  
to be in conformity with  
Un échantillon de ce produit a été essayé et a été  
considéré conforme à la

IEC 60950-1:2005 + A1 + A2  
National differences see test report

As shown in the Test Report Ref. No. which forms part  
of this Certificate  
Comme indiqué dans le Rapport d'essais numéro de  
référence qui constitue partie de ce Certificat

17056170 001

This CB Test Certificate is issued by the National Certification Body  
Ce Certificat d'essai OC est établi par l'Organisme National de Certification



**TÜVRheinland**®

TÜV Rheinland Japan Ltd.  
Global Technology Assessment Center  
4-25-2 Kita-Yamata, Tsuzuki-ku  
Yokohama 224-0021 Japan  
Phone + 81 45 914-3888  
Fax + 81 45 914-3354  
Mail: info@jpn.tuv.com  
Web: www.tuv.com

Date: 14.04.2016

Signature:

Ing. M. Eichenseder

1. TPV Display Technology (Wuhan) Co., Ltd.  
Unique No. 11, Zhuankou Development District of Economic Technological Development Zone, Wuhan City 430056, P.R. China
2. TPV Electronics (Fujian) Co., Ltd.  
Shangzheng, Yuan Hong Road Fuqing City, Fujian Province P.R. China
3. Envision Industry of Electronic Products Ltd.  
Rodovia Anhanguera S/N-KM 49 Tijuco Preto-Jundiá-SP-13.205-700, Brazil
4. L&T Display Technology (Fujian) Ltd.  
Optoelectronic Park, Rongqiao Economic and Technological Development Zone Fuqing, Fujian 350301, P.R. China
5. TPV Electronics (Fujian) Co., Ltd.  
Rongqiao Economic and Technological Development Zone Fuqing City, Fujian Province P.R. China
6. Trend Smart CE Mexico S de RL de CV  
Avenida Sor Juana Ines de la Cruz de 19602 Nueva Tijuana, 22435 Tijuana Baja California MEXICO
7. TPV Display Technology (Beihai) Co., Ltd.  
China Electronic Beihai Industry Park, Northeast of the Crossing Between Taiwan Road and Jilin Road, Beihai City, Guangxi, P.R. China
8. TPV Technology (Qingdao) Co., Ltd.  
No 99 Huoju Road, High-tech Industrial Development Zone Qingdao City, Shandong Province, P.R. China
9. TPV Display Technology (China) Co., Ltd.  
No. 106 Jinghai 3 Rd., BDA Beijing City 100176 P.R. China

**Additional information (if necessary)**  
**Information complémentaire (si nécessaire)**

Report Ref. No.: 17056170 001

Date: 14.04.2016

Signature:

  
Ing. M. Eichenseder

10. Hefei Huntkey Display Technology Co., Ltd.  
South Jinxiu Road, East Qingtan Road  
Economic And Technological  
Development Zone, Hefei, Anhui 230601, P.R. China
11. TPV Electronics (Fujian) Co., Ltd.  
Optoelectronic Park,  
Rongqiao Economic and  
Technological Development Zone,  
Fuqing City, Fujian Province 350301, P.R. China

**Additional information (if necessary)**  
**Information complémentaire (si nécessaire)**

Report Ref. No.: 17056170 001

Date: 14.04.2016

Signature:



Ing. M. Eichenseder

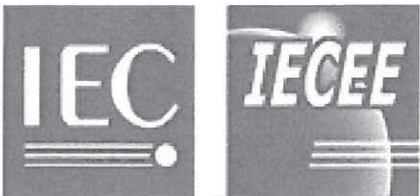

Test Report issued under the responsibility of:



<b>TEST REPORT</b>	
<b>IEC 60950-1</b>	
<b>Information technology equipment – Safety – Part 1: General requirements</b>	
Report Number.....	: 17056170 001
Date of issue.....	: Apr. 12. 2016
Total number of pages .....	: 40
Applicant's name .....	: <b>TPV Electronics (Fujian) Co., Ltd.</b>
Address.....	: Rongqiao Economic and Technological Development Zone, Fuqing City, Fujian Province, P. R. China
<b>Test specification:</b>	
Standard .....	: IEC 60950-1:2005 (Second Edition) + Am 1:2009 + Am 2:2013
Test procedure.....	: CB Scheme
Non-standard test method .....	: N/A
Test Report Form No.....	: IEC60950_1F
Test Report Form(s) Originator....	: SGS Fimko Ltd
Master TRF .....	: Dated 2014-02
<b>Copyright © 2014 IEC System of Conformity Assessment Schemes for Electrotechnical Equipment and Components (IECEE System). All rights reserved.</b>	
This publication may be reproduced in whole or in part for non-commercial purposes as long as the IECEE is acknowledged as copyright owner and source of the material. IECEE takes no responsibility for and will not assume liability for damages resulting from the reader's interpretation of the reproduced material due to its placement and context.	
If this Test Report Form is used by non-IECEE members, the IECEE/IEC logo and the reference to the CB Scheme procedure shall be removed.	
<b>This report is not valid as a CB Test Report unless signed by an approved CB Testing Laboratory and appended to a CB Test Certificate issued by an NCB in accordance with IECEE 02.</b>	
<b>General disclaimer:</b>	
The test results presented in this report relate only to the object tested. This report shall not be reproduced, except in full, without the written approval of the Issuing CB Testing Laboratory. The authenticity of this Test Report and its contents can be verified by contacting the NCB, responsible for this Test Report.	
Test item description.....	: LCD Monitor
Trade Mark.....	: AOC
Manufacturer .....	: Same as applicant
Model/Type reference.....	: **271****, 270LM000** (* can be 0-9, A-Z, a-z, -, \, /, + or blank, represent different enclosure colour and sales regions for marketing purpose only, no technical difference.)
Ratings.....	: I/P: 20Vdc, 6A

<b>Testing procedure and testing location:</b>		
<input checked="" type="checkbox"/>	<b>CB Testing Laboratory:</b>	<b>TÜV Rheinland (Shenzhen) Co., Ltd.</b>
<b>Testing location/ address .....</b>		East of F/1, F/2~F/4, Building 1, Cybio Technology Building No. 6 Langshan No.2 Road, North Hi-tech Industry Park 518057 Shenzhen Nanshan District CHINA
<input type="checkbox"/>	<b>Associated CB Testing Laboratory:</b>	
<b>Testing location/ address .....</b>		
<b>Tested by (name + signature) .....</b>		Anderson Wang 
<b>Approved by (name + signature) .....</b>		Aegean Li 
<input type="checkbox"/>	<b>Testing procedure: TMP/CTF Stage 1:</b>	
<b>Testing location/ address .....</b>		
<b>Tested by (name + signature) .....</b>		
<b>Approved by (name + signature) .....</b>		
<input type="checkbox"/>	<b>Testing procedure: WMT/CTF Stage 2:</b>	
<b>Testing location/ address .....</b>		
<b>Tested by (name + signature) .....</b>		
<b>Witnessed by (name + signature) .....</b>		
<b>Approved by (name + signature) .....</b>		
<input type="checkbox"/>	<b>Testing procedure: SMT/CTF Stage 3 or 4:</b>	
<b>Testing location/ address .....</b>		
<b>Tested by (name + signature) .....</b>		
<b>Witnessed by (name + signature) .....</b>		
<b>Approved by (name + signature) .....</b>		
<b>Supervised by (name + signature) .....</b>		

**List of Attachments (including a total number of pages in each attachment):**

- Photo documentation
- National Differences

Total number of pages in each attachment is indicated in individual attachment.

**Summary of testing:****Tests performed (name of test and test clause):**

Following tests performed during evaluation

name of test	test clause number
Input Current Test	1.6.2
Durability of Marking Test	1.7.11
SELV limits for normal conditions	2.2.2
Limited power sources	2.5
Stability test	4.1
Wall or ceiling mounted	4.2.10
Maximum Temperature Test	4.5.2
Enclosure openings	4.6.2
Fault Condition Test	5.3
Note:	

**Testing location:**

All tests as described in Test Case and Measurement Sections were performed at the laboratory described on page 2.

**Summary of compliance with National Differences**

List of countries addressed:

EU Group Differences, EU Special National Conditions, EU A-Deviations, AT, AU\*, BE, CA, CH, CN, CZ, DE, DK, FI, FR, GB, GR, HU, IT, IL\*, JP\*, KR\*, NL, NO, PL, SE, SI, SK, US

Explanation of used codes: AT=Austria, AU=Australia, BE=Belgium, CA=Canada, CH=Switzerland, CN=P.R.China, CZ=Czech Republic, DE=Germany, DK=Denmark, FI=Finland, FR=France, GB=United Kingdom, GR=Greece, HU=Hungary, IT=Italy, IL=Israel, JP=Japan, KR=Korea, NL=The Netherlands, NO=Norway, PL=Poland, SE=Sweden, SI=Slovenia, SK=Slovakia, US=United States of America

For National Differences see end of this test report.

\* National differences to IEC 60950-1:2005 (Second Edition) + Am 1:2009 evaluated.

The product fulfils the requirements of EN 60950-1:2006 + A11: 2009 + A1: 2010 +A12: 2011 +A2: 2013

Copy of marking plate

The artwork below may be only a draft. The use of certification marks on a product must be authorized by the respective NCBS that own these marks.

**AOC** LCD Monitor(LED Backlight)/液晶顯示器/모니터

Product Name/Name Produk/機種名/세 품명: **AG271QX**

Model No /型 號/모델명: **270LM00027**

Power Rating/Tegangan/額定電源/정격입력: 20V = 6A

제조업체명/상호명: TPV Electronics(Fujian) Co., Ltd  
 Rongqiao Economic and Technological Development Zone,  
 Fuqing City, Fujian Province, P.R. China  
 판매처 (주)알파스캔디스플레이 제조A/S 문의처: 1544 7739  
 福建捷聯電子有限公司  
 福建省福清市融僑經濟技術開發區  
 AOC International  
 Europe B.V. Amstelgebouw,  
 6th floor Prins Bernhardplein  
 200 1097 JB Amsterdam  
 The Netherlands  
 www.aoc.com  
 Made in China/Buatan China/  
 제조국 중국/中國製造

Q40G027E-615-57A

Warning: Shock Hazard, Do Not Open.  
 高壓注意: 非專業維修人員請勿打開後蓋。  
 警告: 使用過度恐傷害視力  
 CAN ICES-3(B)/NMB-3(B)  
 For applicable power supplies see user manual.  
 適用的電源適配器請參閱說明書。

MSIP-REM-TPF-270LM00027

CE

EAC

VCCI

FC

TUV Rheinland

R33037 RoHS

Barcode area: **BARCODE**

Note: The above label represents labels for model names other than above covered by the model name.



<b>Test item particulars</b> .....	
<b>Equipment mobility</b> .....	<input checked="" type="checkbox"/> movable (for unit with base stand) <input type="checkbox"/> hand-held <input type="checkbox"/> transportable <input checked="" type="checkbox"/> stationary (for unit without base stand) <input type="checkbox"/> for building-in <input type="checkbox"/> direct plug-in
<b>Connection to the mains</b> .....	<input type="checkbox"/> pluggable equipment <input type="checkbox"/> type A <input type="checkbox"/> type B <input type="checkbox"/> permanent connection <input type="checkbox"/> detachable power supply cord <input type="checkbox"/> non-detachable power supply cord <input checked="" type="checkbox"/> not directly connected to the mains
<b>Operating condition</b> .....	<input checked="" type="checkbox"/> continuous <input type="checkbox"/> rated operating / resting time:
<b>Access location</b> .....	<input checked="" type="checkbox"/> operator accessible <input type="checkbox"/> restricted access location
<b>Over voltage category (OVC)</b> .....	<input type="checkbox"/> OVC I <input type="checkbox"/> OVC II <input type="checkbox"/> OVC III <input type="checkbox"/> OVC IV <input checked="" type="checkbox"/> other: not directly connected to the mains.
<b>Mains supply tolerance (%) or absolute mains supply values</b> .....	N/A
<b>Tested for IT power systems</b> .....	<input type="checkbox"/> Yes <input checked="" type="checkbox"/> No
<b>IT testing, phase-phase voltage (V)</b> .....	N/A
<b>Class of equipment</b> .....	<input type="checkbox"/> Class I <input type="checkbox"/> Class II <input checked="" type="checkbox"/> Class III <input type="checkbox"/> Not classified
<b>Considered current rating of protective device as part of the building installation (A)</b> .....	N/A
<b>Pollution degree (PD)</b> .....	<input type="checkbox"/> PD 1 <input checked="" type="checkbox"/> PD 2 <input type="checkbox"/> PD 3
<b>IP protection class</b> .....	IPX0
<b>Altitude during operation (m)</b> .....	≤5000
<b>Altitude of test laboratory (m)</b> .....	<2000
<b>Mass of equipment (kg)</b> .....	Unit with base: approx. 6.5kg; Base: approx. 2.3kg
<b>Possible test case verdicts:</b>	
- test case does not apply to the test object.....	N/A
- test object does meet the requirement.....	P (Pass)
- test object does not meet the requirement.....	F (Fail)
<b>Testing</b> .....	
<b>Date of receipt of test item</b> .....	24.Mar.2016
<b>Date(s) of performance of tests</b> .....	01.Apr.2016 – 08.Apr.2016
<b>General remarks:</b>	
"(See Enclosure #)" refers to additional information appended to the report. "(See appended table)" refers to a table appended to the report.	
Throughout this report a <input type="checkbox"/> comma / <input checked="" type="checkbox"/> point is used as the decimal separator.	

**Manufacturer's Declaration per sub-clause 4.2.5 of IECEE 02:**

The application for obtaining a CB Test Certificate includes more than one factory location and a declaration from the Manufacturer stating that the sample(s) submitted for evaluation is (are) representative of the products from each factory has been provided .....

 **Yes** **Not applicable**

**When differences exist; they shall be identified in the General product information section.**

Name and address of factory (ies).....	
	1 TPV Display Technology (Wuhan) Co., Ltd. Unique No. 11, Zhuankou Development District of Economic Technological Development Zone, Wuhan City 430056, P.R. China
	2 TPV Electronics (Fujian) Co., Ltd. Shangzheng, Yuan Hong Road, Fuqing City, Fujian Province, P.R. China
	3 Envision Industry of Electronic Products Ltd. Rodovia Anhanguera S/N-KM 49, Tijuco Preto-Jundiaí-SP-13.205-700, Brazil
	4 L&T Display Technology (Fujian) Ltd. Optoelectronic Park, Rongqiao Economic and Technological, Development Zone, Fuqing, Fujian 350301, P.R. China
	5 TPV Electronics (Fujian) Co., Ltd. Rongqiao Economic and Technological Development Zone, Fuqing City, Fujian Province, P.R. China
	6 Trend Smart CE Mexico S de RL de CV Avenida Sor Juana Ines de la Cruz de 19602 Nueva Tijuana, 22435 Tijuans Baja California, MEXICO
	7 TPV Display Technology (Beihai) Co., Ltd. China Electronic Beihai Industry Park, Northeast of the Crossing Between Taiwan Road and Jilin Road, Beihai City, Guangxi, P.R. China
	8 TPV Technology (Qingdao) Co., Ltd. No.99 Huoju Road, High-tech Industrial Development Zone, Qingdao City, Shandong Province, P.R. China
	9 TPV Display Technology (China) Co., Ltd. No.106 Jinghai 3 Rd., BDA, Beijing City 100176, P.R. China.
	10 Hefei Huntkey Display Technology Co.,Ltd. South Jinxiu Road, East Qingtan Road, Economic And Technological Development Zone, Hefei, Anhui 230601, P.R. China
	11 TPV Electronics (Fujian) Co., Ltd. Optoelectronic Park, Rongqiao Economic and Technological Development Zone, Fuqing City, Fujian Province 350301, P.R.China

**General product information:**

The models mentioned on cover page are LCD monitor with LED backlight which are intended for general office use. The models are identical except for type designation.

The unit has the following features:

1. LCD Type: 27 inch TFT LCD with LED backlight (resolution: 2560 x 1440);
2. External approved adapter used: ADPC20120, which is complied with the requirement of 5000m altitude during operation;
3. DC/DC converter board 715G5858, supplied by external adapter mentioned above;
4. Main boards: 715G8055 with VGA, DVI, HDMI, HDMI with MHL, DisplayPort, Audio-in and Audio-out ports, 715G8083 with DisplayPort and HDMI ports, which are supplied by AC/DC adapter mentioned above;
5. USB board 715G8049 with one USB 3.0 upstream port, two USB 3.0 downstream port, one USB 3.0 downstream with fast charging ports and audio-out port, Audio-in and Audio-out ports;
6. The internal metal enclosure is regarded as fire enclosure
7. Maximum declared ambient: 40°C.

**Abbreviations used in the report:**

- normal conditions	<b>N.C.</b>	- single fault conditions	<b>S.F.C</b>
- functional insulation	<b>OP</b>	- basic insulation	<b>BI</b>
- double insulation	<b>DI</b>	- supplementary insulation	<b>SI</b>
- between parts of opposite polarity	<b>BOP</b>	- reinforced insulation	<b>RI</b>

**Indicate used abbreviations (if any)**

<b>IEC 60950-1</b>			
Clause	Requirement + Test	Result - Remark	Verdict
<b>1</b>	<b>GENERAL</b>		
<b>1.5</b>	<b>Components</b>		
1.5.1	General		
	Comply with IEC 60950-1 or relevant component standard	(see appended table 1.5.1)	P
1.5.2	Evaluation and testing of components	Components which are certified to IEC and/or national standards are used correctly within their ratings. Components not covered by IEC standards are tested under the conditions present in the equipment.	P
1.5.3	Thermal controls	No thermal controls.	N/A
1.5.4	Transformers	Considered in approved external adapters.	N/A
1.5.5	Interconnecting cables	Interconnecting cable does not carry voltage higher than SELV and no higher energy level than 240VA.	P
1.5.6	Capacitors bridging insulation	Considered in approved external adapter.	N/A
1.5.7	Resistors bridging insulation	Considered in approved external adapter.	N/A
1.5.7.1	Resistors bridging functional, basic or supplementary insulation		N/A
1.5.7.2	Resistors bridging double or reinforced insulation between a.c. mains and other circuits		N/A
1.5.7.3	Resistors bridging double or reinforced insulation between a.c. mains and antenna or coaxial cable		N/A
1.5.8	Components in equipment for IT power systems	No such component.	N/A
1.5.9	Surge suppressors	No such component.	N/A
1.5.9.1	General		N/A
1.5.9.2	Protection of VDRs		N/A
1.5.9.3	Bridging of functional insulation by a VDR		N/A
1.5.9.4	Bridging of basic insulation by a VDR		N/A
1.5.9.5	Bridging of supplementary, double or reinforced insulation by a VDR		N/A
<b>1.6</b>	<b>Power interface</b>		P

<b>IEC 60950-1</b>			
Clause	Requirement + Test	Result - Remark	Verdict
1.6.1	AC power distribution systems	Unit is not directly connected to the AC mains.	N/A
1.6.2	Input current	(see appended table 1.6.2)	P
1.6.3	Voltage limit of hand-held equipment	This appliance is not hand-held equipment.	N/A
1.6.4	Neutral conductor		N/A

<b>1.7</b>	<b>Marking and instructions</b>		P
1.7.1	Power rating and identification markings	See below.	P
1.7.1.1	Power rating marking	See marking on Page 4 for details	P
	Multiple mains supply connections.....:		P
	Rated voltage(s) or voltage range(s) (V) .....	See marking on Page 4 for details	P
	Symbol for nature of supply, for d.c. only .....	See marking on Page 4 for details	P
	Rated frequency or rated frequency range (Hz) .....	Class III equipment.	N/A
	Rated current (mA or A) .....	See marking on Page 4 for details	P
1.7.1.2	Identification markings		P
	Manufacturer's name or trade-mark or identification mark .....	See marking on Page 4 for details	P
	Model identification or type reference .....	See marking on Page 4 for details	P
	Symbol for Class II equipment only .....	Class III equipment.	N/A
	Other markings and symbols .....	Additional symbol or marking does not give rise to misunderstanding.	P
1.7.1.3	Use of graphical symbols		N/A
1.7.2	Safety instructions and marking	English safety instruction provided.	P
1.7.2.1	General		P
1.7.2.2	Disconnect devices		N/A
1.7.2.3	Overcurrent protective device		N/A
1.7.2.4	IT power distribution systems		N/A
1.7.2.5	Operator access with a tool	No such access required.	N/A
1.7.2.6	Ozone	Ozone not used or generated.	N/A
1.7.3	Short duty cycles	Equipment is designed for continuous operation.	N/A

<b>IEC 60950-1</b>			
Clause	Requirement + Test	Result - Remark	Verdict
1.7.4	Supply voltage adjustment .....		N/A
	Methods and means of adjustment; reference to installation instructions .....		N/A
1.7.5	Power outlets on the equipment .....	No power outlets provided.	N/A
1.7.6	Fuse identification (marking, special fusing characteristics, cross-reference) .....	Considered in approved external adapter.	N/A
1.7.7	Wiring terminals	See below.	P
1.7.7.1	Protective earthing and bonding terminals .....	No earthing terminals and bonding terminals	N/A
1.7.7.2	Terminals for a.c. mains supply conductors	Not connected to a.c. mains	N/A
1.7.7.3	Terminals for d.c. mains supply conductors	Not connected to d.c. mains	N/A
1.7.8	Controls and indicators	See below	P
1.7.8.1	Identification, location and marking .....	"STAND-BY" condition is indicated by the symbol according to 60417-1-IEC-5009.	P
1.7.8.2	Colours .....	Colours used for LED indicate the operation status and not involved safety.	P
1.7.8.3	Symbols according to IEC 60417 .....	See 1.7.8.1	P
1.7.8.4	Markings using figures .....	No figures used.	N/A
1.7.9	Isolation of multiple power sources .....	Only one supply voltage range provided.	N/A
1.7.10	Thermostats and other regulating devices .....	No such components.	N/A
1.7.11	Durability	The label was subjected to the permanence of marking test. The label was rubbed with cloth soaked with water for 15 sec. and then again for 15 sec. with the cloth soaked with petroleum spirit.  After this test there was no damage to the label. The marking on the label did not fade. There was no curling or lifting of the label edge.	P
1.7.12	Removable parts	None.	N/A
1.7.13	Replaceable batteries .....	No batteries.	N/A
	Language(s) .....		—
1.7.14	Equipment for restricted access locations .....	Equipment not intended for installation in restricted access locations.	N/A

<b>IEC 60950-1</b>			
Clause	Requirement + Test	Result - Remark	Verdict
<b>2</b>	<b>PROTECTION FROM HAZARDS</b> <i>EUT supplied by approved switching AC/DC adapter, no hazards inside</i>		P
<b>2.1</b>	<b>Protection from electric shock and energy hazards</b>		P
2.1.1	Protection in operator access areas	Only SELV signal interface accessible by operator.	P
2.1.1.1	Access to energized parts	No hazardous voltage inside, class III product	P
	Test by inspection .....		N/A
	Test with test finger (Figure 2A) .....		N/A
	Test with test pin (Figure 2B) .....		N/A
	Test with test probe (Figure 2C) .....		N/A
2.1.1.2	Battery compartments	No battery compartment.	N/A
2.1.1.3	Access to ELV wiring	No ELV wiring in operator accessible area.	N/A
	Working voltage ( $V_{peak}$ or $V_{rms}$ ); minimum distance through insulation (mm)		—
2.1.1.4	Access to hazardous voltage circuit wiring	No hazardous voltage wiring in operator accessible area.	N/A
2.1.1.5	Energy hazards .....	Supplied by SELV having a energy level less than 240VA	P
2.1.1.6	Manual controls	No manual controls.	N/A
2.1.1.7	Discharge of capacitors in equipment	Considered in approved external adapter.	N/A
	Measured voltage (V); time-constant (s) .....		—
2.1.1.8	Energy hazards – d.c. mains supply		N/A
	a) Capacitor connected to the d.c. mains supply ...:		N/A
	b) Internal battery connected to the d.c. mains supply .....		N/A
2.1.1.9	Audio amplifiers .....		N/A
2.1.2	Protection in service access areas	No service access area.	N/A
2.1.3	Protection in restricted access locations	Equipment not intended for installation in restricted access locations	N/A
<b>2.2</b>	<b>SELV circuits</b>		P
2.2.1	General requirements	See below	P
2.2.2	Voltages under normal conditions (V) .....	42.4V peak or 60Vd.c. are not exceeded in SELV circuit under normal operation. (See appended table 2.2.2)	P

<b>IEC 60950-1</b>			
Clause	Requirement + Test	Result - Remark	Verdict
2.2.3	Voltages under fault conditions (V) .....	Considered in approved external adapter.	N/A
2.2.4	Connection of SELV circuits to other circuits .....	Connect to SELV circuit	P

<b>2.3</b>	<b>TNV circuits</b>	<i>No TNV circuits</i>	N/A
2.3.1	Limits		N/A
	Type of TNV circuits .....		—
2.3.2	Separation from other circuits and from accessible parts		N/A
2.3.2.1	General requirements		N/A
2.3.2.2	Protection by basic insulation		N/A
2.3.2.3	Protection by earthing		N/A
2.3.2.4	Protection by other constructions .....		N/A
2.3.3	Separation from hazardous voltages		N/A
	Insulation employed .....		—
2.3.4	Connection of TNV circuits to other circuits		N/A
	Insulation employed .....		—
2.3.5	Test for operating voltages generated externally		N/A

<b>2.4</b>	<b>Limited current circuits</b>	<i>No limited current circuits, requirements not applicable to the evaluated product.</i>	
2.4.1	General requirements		N/A
2.4.2	Limit values		N/A
	Frequency (Hz) .....		—
	Measured current (mA).....		—
	Measured voltage (V) .....		—
	Measured circuit capacitance (nF or $\mu$ F) .....		—
2.4.3	Connection of limited current circuits to other circuits		N/A

<b>2.5</b>	<b>Limited power sources</b>		P
	a) Inherently limited output		N/A
	b) Impedance limited output		N/A
	c) Regulating network or IC current limiter, limits output under normal operating and single fault condition		N/A
	Use of integrated circuit (IC) current limiters		N/A



IEC 60950-1			
Clause	Requirement + Test	Result - Remark	Verdict
	d) Overcurrent protective device limited output	Fuse F701 limits all output of +19V of two main boards, compliance with table 2C under normal operating conditions.	P
	Max. output voltage (V), max. output current (A), max. apparent power (VA).....:		—
	Current rating of overcurrent protective device (A):	See Table 1.5.1	—

<b>2.6</b>	<b>Provisions for earthing and bonding</b> <i>EUT supplied by approved class I switching AC/DC adapter</i>		N/A
2.6.1	Protective earthing		N/A
2.6.2	Functional earthing		N/A
	Use of symbol for functional earthing .....		N/A
2.6.3	Protective earthing and protective bonding conductors		N/A
2.6.3.1	General		N/A
2.6.3.2	Size of protective earthing conductors		N/A
	Rated current (A), cross-sectional area (mm <sup>2</sup> ), AWG .....		—
2.6.3.3	Size of protective bonding conductors		N/A
	Rated current (A), cross-sectional area (mm <sup>2</sup> ), AWG .....		—
	Protective current rating (A), cross-sectional area (mm <sup>2</sup> ), AWG .....		—
2.6.3.4	Resistance of earthing conductors and their terminations; resistance ( $\Omega$ ), voltage drop (V), test current (A), duration (min) .....		N/A
2.6.3.5	Colour of insulation .....		N/A
2.6.4	Terminals		N/A
2.6.4.1	General		N/A
2.6.4.2	Protective earthing and bonding terminals		N/A
	Rated current (A), type, nominal thread diameter (mm) .....		—
2.6.4.3	Separation of the protective earthing conductor from protective bonding conductors		N/A
2.6.5	Integrity of protective earthing		N/A
2.6.5.1	Interconnection of equipment		N/A
2.6.5.2	Components in protective earthing conductors and protective bonding conductors		N/A
2.6.5.3	Disconnection of protective earth		N/A

<b>IEC 60950-1</b>			
Clause	Requirement + Test	Result - Remark	Verdict
2.6.5.4	Parts that can be removed by an operator		N/A
2.6.5.5	Parts removed during servicing		N/A
2.6.5.6	Corrosion resistance		N/A
2.6.5.7	Screws for protective bonding		N/A
2.6.5.8	Reliance on telecommunication network or cable distribution system		N/A

<b>2.7</b>	<b>Overcurrent and earth fault protection in primary circuits</b> <i>Considered in approved switching AC/DC adapter</i>		N/A
2.7.1	Basic requirements		N/A
	Instructions when protection relies on building installation		N/A
2.7.2	Faults not simulated in 5.3.7		N/A
2.7.3	Short-circuit backup protection		N/A
2.7.4	Number and location of protective devices ..... :		N/A
2.7.5	Protection by several devices		N/A
2.7.6	Warning to service personnel ..... :		N/A

<b>2.8</b>	<b>Safety interlocks</b>		N/A
2.8.1	General principles		N/A
2.8.2	Protection requirements		N/A
2.8.3	Inadvertent reactivation		N/A
2.8.4	Fail-safe operation		N/A
	Protection against extreme hazard		N/A
2.8.5	Moving parts		N/A
2.8.6	Overriding		N/A
2.8.7	Switches, relays and their related circuits		N/A
2.8.7.1	Separation distances for contact gaps and their related circuits (mm) ..... :		N/A
2.8.7.2	Overload test		N/A
2.8.7.3	Endurance test		N/A
2.8.7.4	Electric strength test		N/A
2.8.8	Mechanical actuators		N/A

<b>2.9</b>	<b>Electrical insulation</b> <i>Approved switching AC/DC adapter used, only functional insulation considered in EUT</i>		P
------------	--	--	---

IEC 60950-1			
Clause	Requirement + Test	Result - Remark	Verdict
2.9.1	Properties of insulating materials	Function insulation Considered.	P
2.9.2	Humidity conditioning		N/A
	Relative humidity (%), temperature (°C) ..... :		—
2.9.3	Grade of insulation	Function insulation Considered.	P
2.9.4	Separation from hazardous voltages		N/A
	Method(s) used ..... :		—

<b>2.10</b>	<b>Clearances, creepage distances and distances through insulation</b> <i>Approved switching AC/DC adapter used, only functional insulation considered in EUT, see appended table 5.3 for details</i>		N/A
2.10.1	General		N/A
2.10.1.1	Frequency .....:		N/A
2.10.1.2	Pollution degrees .....:		N/A
2.10.1.3	Reduced values for functional insulation		N/A
2.10.1.4	Intervening unconnected conductive parts		N/A
2.10.1.5	Insulation with varying dimensions		N/A
2.10.1.6	Special separation requirements		N/A
2.10.1.7	Insulation in circuits generating starting pulses		N/A
2.10.2	Determination of working voltage		N/A
2.10.2.1	General		N/A
2.10.2.2	RMS working voltage		N/A
2.10.2.3	Peak working voltage		N/A
2.10.3	Clearances		N/A
2.10.3.1	General		N/A
2.10.3.2	Mains transient voltages		N/A
	a) AC mains supply .....:		N/A
	b) Earthed d.c. mains supplies .....:		N/A
	c) Unearthed d.c. mains supplies .....:		N/A
	d) Battery operation .....:		N/A
2.10.3.3	Clearances in primary circuits		N/A
2.10.3.4	Clearances in secondary circuits		N/A
2.10.3.5	Clearances in circuits having starting pulses		N/A
2.10.3.6	Transients from a.c. mains supply .....:		N/A
2.10.3.7	Transients from d.c. mains supply .....:		N/A
2.10.3.8	Transients from telecommunication networks and cable distribution systems .....:		N/A

<b>IEC 60950-1</b>			
Clause	Requirement + Test	Result - Remark	Verdict
2.10.3.9	Measurement of transient voltage levels		N/A
	a) Transients from a mains supply		N/A
	For an a.c. mains supply .....		N/A
	For a d.c. mains supply .....		N/A
	b) Transients from a telecommunication network :		N/A
2.10.4	Creepage distances		N/A
2.10.4.1	General		N/A
2.10.4.2	Material group and comparative tracking index		N/A
	CTI tests .....		—
2.10.4.3	Minimum creepage distances		N/A
2.10.5	Solid insulation		N/A
2.10.5.1	General		N/A
2.10.5.2	Distances through insulation		N/A
2.10.5.3	Insulating compound as solid insulation		N/A
2.10.5.4	Semiconductor devices		N/A
2.10.5.5.	Cemented joints		N/A
2.10.5.6	Thin sheet material – General		N/A
2.10.5.7	Separable thin sheet material		N/A
	Number of layers (pcs) .....		—
2.10.5.8	Non-separable thin sheet material		N/A
2.10.5.9	Thin sheet material – standard test procedure		N/A
	Electric strength test		—
2.10.5.10	Thin sheet material – alternative test procedure		N/A
	Electric strength test		—
2.10.5.11	Insulation in wound components		N/A
2.10.5.12	Wire in wound components		N/A
	Working voltage .....		N/A
	a) Basic insulation not under stress .....		N/A
	b) Basic, supplementary, reinforced insulation .....		N/A
	c) Compliance with Annex U .....		N/A
	Two wires in contact inside wound component; angle between 45° and 90° .....		N/A
2.10.5.13	Wire with solvent-based enamel in wound components		N/A
	Electric strength test		—
	Routine test		N/A
2.10.5.14	Additional insulation in wound components		N/A

<b>IEC 60950-1</b>			
Clause	Requirement + Test	Result - Remark	Verdict
	Working voltage .....		N/A
	- Basic insulation not under stress .....		N/A
	- Supplementary, reinforced insulation .....		N/A
2.10.6	Construction of printed boards		N/A
2.10.6.1	Uncoated printed boards		N/A
2.10.6.2	Coated printed boards		N/A
2.10.6.3	Insulation between conductors on the same inner surface of a printed board		N/A
2.10.6.4	Insulation between conductors on different layers of a printed board		N/A
	Distance through insulation		N/A
	Number of insulation layers (pcs) .....		N/A
2.10.7	Component external terminations		N/A
2.10.8	Tests on coated printed boards and coated components		N/A
2.10.8.1	Sample preparation and preliminary inspection		N/A
2.10.8.2	Thermal conditioning		N/A
2.10.8.3	Electric strength test		N/A
2.10.8.4	Abrasion resistance test		N/A
2.10.9	Thermal cycling		N/A
2.10.10	Test for Pollution Degree 1 environment and insulating compound		N/A
2.10.11	Tests for semiconductor devices and cemented joints		N/A
2.10.12	Enclosed and sealed parts		N/A

<b>3</b>	<b>WIRING, CONNECTIONS AND SUPPLY</b>		P
<b>3.1</b>	<b>General</b>		P
3.1.1	Current rating and overcurrent protection	The internal wires have suitable size to carry rated current	P
3.1.2	Protection against mechanical damage	Wires do not touch sharp edges which could damage the insulation and cause hazard.	P
3.1.3	Securing of internal wiring	Wires are secured by soldering method and additionally fixed by glue or by connectors.	P

<b>IEC 60950-1</b>			
Clause	Requirement + Test	Result - Remark	Verdict
3.1.4	Insulation of conductors	The insulation of the individual conductors suitable for the application and the working voltage. For the insulation material see 3.1.1.	P
3.1.5	Beads and ceramic insulators	Not used.	N/A
3.1.6	Screws for electrical contact pressure		N/A
3.1.7	Insulating materials in electrical connections		N/A
3.1.8	Self-tapping and spaced thread screws	No self-tapping screws are used.	N/A
3.1.9	Termination of conductors	All conductors are reliably secured.	P
	10 N pull test		P
3.1.10	Sleeving on wiring		N/A

<b>3.2</b>	<b>Connection to a mains supply</b>		N/A
		<i>EUT not connected to mains directly</i>	
3.2.1	Means of connection		N/A
3.2.1.1	Connection to an a.c. mains supply		N/A
3.2.1.2	Connection to a d.c. mains supply		N/A
3.2.2	Multiple supply connections		N/A
3.2.3	Permanently connected equipment		N/A
	Number of conductors, diameter of cable and conduits (mm) .....		—
3.2.4	Appliance inlets		N/A
3.2.5	Power supply cords		N/A
3.2.5.1	AC power supply cords		N/A
	Type .....		—
	Rated current (A), cross-sectional area (mm <sup>2</sup> ), AWG .....		—
3.2.5.2	DC power supply cords		N/A
3.2.6	Cord anchorages and strain relief		N/A
	Mass of equipment (kg), pull (N) .....		—
	Longitudinal displacement (mm) .....		—
3.2.7	Protection against mechanical damage		N/A
3.2.8	Cord guards		N/A
	Diameter or minor dimension D (mm); test mass (g) .....		—

IEC 60950-1			
Clause	Requirement + Test	Result - Remark	Verdict

	Radius of curvature of cord (mm)..... :		—
3.2.9	Supply wiring space		N/A

<b>3.3</b>	<b>Wiring terminals for connection of external conductors</b>		N/A
3.3.1	Wiring terminals		N/A
3.3.2	Connection of non-detachable power supply cords		N/A
3.3.3	Screw terminals		N/A
3.3.4	Conductor sizes to be connected		N/A
	Rated current (A), cord/cable type, cross-sectional area (mm <sup>2</sup> )..... :		—
3.3.5	Wiring terminal sizes		N/A
	Rated current (A), type, nominal thread diameter (mm) .....		—
3.3.6	Wiring terminal design		N/A
3.3.7	Grouping of wiring terminals		N/A
3.3.8	Stranded wire		N/A

<b>3.4</b>	<b>Disconnection from the mains supply</b>	<i>EUT not connected to mains directly</i>	N/A
3.4.1	General requirement		N/A
3.4.2	Disconnect devices		N/A
3.4.3	Permanently connected equipment		N/A
3.4.4	Parts which remain energized		N/A
3.4.5	Switches in flexible cords		N/A
3.4.6	Number of poles - single-phase and d.c. equipment		N/A
3.4.7	Number of poles - three-phase equipment		N/A
3.4.8	Switches as disconnect devices		N/A
3.4.9	Plugs as disconnect devices		N/A
3.4.10	Interconnected equipment		N/A
3.4.11	Multiple power sources		N/A

<b>3.5</b>	<b>Interconnection of equipment</b>		P
3.5.1	General requirements	This power supply is not considered for connection to TNV.	P

IEC 60950-1			
Clause	Requirement + Test	Result - Remark	Verdict
3.5.2	Types of interconnection circuits .....	Interconnection circuits of SELV through the connector. No ELV interconnection circuits.	P
3.5.3	ELV circuits as interconnection circuits	No ELV interconnection	N/A
3.5.4	Data ports for additional equipment	All data ports are located on the main board, which is supplied by LPS.	P

<b>4</b>	<b>PHYSICAL REQUIREMENTS</b>		P
<b>4.1</b>	<b>Stability</b>		P
	Angle of 10°	Test performed by client's request.	P
	Test force (N) .....	Equipment is not a floor standing unit.	N/A

<b>4.2</b>	<b>Mechanical strength</b> <i>EUT supplied by approved switching AC/DC adapter, no hazardous live parts inside</i>		P
4.2.1	General		N/A
	Rack-mounted equipment.		N/A
4.2.2	Steady force test, 10 N		N/A
4.2.3	Steady force test, 30 N		N/A
4.2.4	Steady force test, 250 N		N/A
4.2.5	Impact test		N/A
	Fall test		N/A
	Swing test		N/A
4.2.6	Drop test; height (mm) .....		N/A
4.2.7	Stress relief test		N/A
4.2.8	Cathode ray tubes	No CRT	N/A
	Picture tube separately certified .....		N/A
4.2.9	High pressure lamps		N/A
4.2.10	Wall or ceiling mounted equipment; force (N) .....	An additional force 123.5N required by client applied downwards through the centre of gravity of the equipment for 1 min after the removal of base. After the test, the equipment was not damaged. (123.5N = 3 x 4.2 x 9.8N)	P



<b>IEC 60950-1</b>			
Clause	Requirement + Test	Result - Remark	Verdict
<b>4.3</b>	<b>Design and construction</b>		P
4.3.1	Edges and corners	Edges and corners of the enclosure are rounded.	P
4.3.2	Handles and manual controls; force (N) ..... :	No safety relevant handles or manual controls.	N/A
4.3.3	Adjustable controls	No such controls.	N/A
4.3.4	Securing of parts	All parts secured properly.	P
4.3.5	Connection by plugs and sockets		N/A
4.3.6	Direct plug-in equipment	Not such equipment.	N/A
	Torque ..... :		—
	Compliance with the relevant mains plug standard ..... :		N/A
4.3.7	Heating elements in earthed equipment	None.	N/A
4.3.8	Batteries	No batteries.	N/A
	- Overcharging of a rechargeable battery		N/A
	- Unintentional charging of a non-rechargeable battery		N/A
	- Reverse charging of a rechargeable battery		N/A
	- Excessive discharging rate for any battery		N/A
4.3.9	Oil and grease	None.	N/A
4.3.10	Dust, powders, liquids and gases	Equipment in intended use not considered to be exposed to these.	N/A
4.3.11	Containers for liquids or gases	None	N/A
4.3.12	Flammable liquids ..... :	None	N/A
	Quantity of liquid (l) ..... :		N/A
	Flash point (°C) ..... :		N/A
4.3.13	Radiation		P
4.3.13.1	General	See below	P
4.3.13.2	Ionizing radiation	No ionizing radiation.	N/A
	Measured radiation (pA/kg) ..... :		—
	Measured high-voltage (kV) ..... :		—
	Measured focus voltage (kV) ..... :		—
	CRT markings ..... :		—
4.3.13.3	Effect of ultraviolet (UV) radiation on materials	No ultraviolet radiation	N/A
	Part, property, retention after test, flammability classification ..... :		N/A
4.3.13.4	Human exposure to ultraviolet (UV) radiation ..... :	No ultraviolet radiation	N/A

IEC 60950-1			
Clause	Requirement + Test	Result - Remark	Verdict
4.3.13.5	Lasers (including laser diodes) and LEDs	The LED is considered as indicating light.	P
4.3.13.5.1	Lasers (including laser diodes)		N/A
	Laser class .....		—
4.3.13.5.2	Light emitting diodes (LEDs)	Lower power of Indicating LED on secondary, which is used for indicating light only.	—
4.3.13.6	Other types .....		N/A

<b>4.4</b>	<b>Protection against hazardous moving parts</b>		N/A
4.4.1	General		N/A
4.4.2	Protection in operator access areas .....		N/A
	Household and home/office document/media shredders		N/A
4.4.3	Protection in restricted access locations .....		N/A
4.4.4	Protection in service access areas		N/A
4.4.5	Protection against moving fan blades		N/A
4.4.5.1	General		N/A
	Not considered to cause pain or injury. a) .....		N/A
	Is considered to cause pain, not injury. b) .....		N/A
	Considered to cause injury. c) .....		N/A
4.4.5.2	Protection for users		N/A
	Use of symbol or warning .....		N/A
4.4.5.3	Protection for service persons		N/A
	Use of symbol or warning .....		N/A

<b>4.5</b>	<b>Thermal requirements</b>		P
4.5.1	General	No parts exceeding temperature limits.	P
4.5.2	Temperature tests	(see appended table 4.5)	P
	Normal load condition per Annex L .....	Equipment loaded with rated output current.	—
4.5.3	Temperature limits for materials	(see appended table 4.5)	P
4.5.4	Touch temperature limits	(see appended table 4.5)	P
4.5.5	Resistance to abnormal heat .....	Considered in approved switching AC/DC adapter	N/A

<b>4.6</b>	<b>Openings in enclosures</b>		P
4.6.1	Top and side openings		N/A

<b>IEC 60950-1</b>			
Clause	Requirement + Test	Result - Remark	Verdict
	Dimensions (mm) .....		—
4.6.2	Bottoms of fire enclosures	(see appended table 4.6.1 and 4.6.2)	P
	Construction of the bottom, dimensions (mm) ..		—
4.6.3	Doors or covers in fire enclosures	No doors or covers.	N/A
4.6.4	Openings in transportable equipment	Not transportable equipment.	N/A
4.6.4.1	Constructional design measures		N/A
	Dimensions (mm) .....		—
4.6.4.2	Evaluation measures for larger openings		N/A
4.6.4.3	Use of metallized parts		N/A
4.6.5	Adhesives for constructional purposes	No adhesives for constructional purposes.	N/A
	Conditioning temperature (°C), time (weeks) .....		—

<b>4.7</b>	<b>Resistance to fire</b>		<b>P</b>
4.7.1	Reducing the risk of ignition and spread of flame	No excessive temperatures. No easily burning materials employed. Fire enclosure provided. Safety relevant components used within their specified temperature limits.	P
	Method 1, selection and application of components wiring and materials		P
	Method 2, application of all of simulated fault condition tests		N/A
4.7.2	Conditions for a fire enclosure	With having the following parts: - Components in secondary (not supplied by LPS, and not applied all fault condition test)  The buttons control board is outside the fire enclosure as it is supplied by the 5V LPS and mounted on PCB of class V-1 or better material.  Internal metal enclosure used as fire enclosure.	P
4.7.2.1	Parts requiring a fire enclosure	See above.	P
4.7.2.2	Parts not requiring a fire enclosure	For components in secondary circuits supplied by LPS.	P
4.7.3	Materials		P
4.7.3.1	General	PCB rated V-1 or better.	P

<b>IEC 60950-1</b>			
Clause	Requirement + Test	Result - Remark	Verdict
4.7.3.2	Materials for fire enclosures	Metal enclosure is considered as fire enclosure, which complies without test.	P
4.7.3.3	Materials for components and other parts outside fire enclosures	HB plastic enclosure used, which is outside the fire enclosure.	P
4.7.3.4	Materials for components and other parts inside fire enclosures	Internal components except small parts are V-2, HF-2 or better.	P
4.7.3.5	Materials for air filter assemblies	No air filter.	N/A
4.7.3.6	Materials used in high-voltage components	No such high voltage components in this meaning	N/A

<b>5</b>	<b>ELECTRICAL REQUIREMENTS AND SIMULATED ABNORMAL CONDITIONS</b>		P
<b>5.1</b>	<b>Touch current and protective conductor current</b> <i>EUT supplied by approved switching AC/DC adapter</i>		N/A
5.1.1	General		N/A
5.1.2	Configuration of equipment under test (EUT)		N/A
5.1.2.1	Single connection to an a.c. mains supply		N/A
5.1.2.2	Redundant multiple connections to an a.c. mains supply		N/A
5.1.2.3	Simultaneous multiple connections to an a.c. mains supply		N/A
5.1.3	Test circuit		N/A
5.1.4	Application of measuring instrument		N/A
5.1.5	Test procedure		N/A
5.1.6	Test measurements		N/A
	Supply voltage (V) .....		—
	Measured touch current (mA) .....		—
	Max. allowed touch current (mA) .....		—
	Measured protective conductor current (mA) .....		—
	Max. allowed protective conductor current (mA) ...:		—
5.1.7	Equipment with touch current exceeding 3,5 mA		N/A
5.1.7.1	General .....		N/A
5.1.7.2	Simultaneous multiple connections to the supply		N/A
5.1.8	Touch currents to telecommunication networks and cable distribution systems and from telecommunication networks		N/A

<b>IEC 60950-1</b>			
Clause	Requirement + Test	Result - Remark	Verdict
5.1.8.1	Limitation of the touch current to a telecommunication network or to a cable distribution system		N/A
	Supply voltage (V) .....		—
	Measured touch current (mA) .....		—
	Max. allowed touch current (mA) .....		—
5.1.8.2	Summation of touch currents from telecommunication networks		N/A
	a) EUT with earthed telecommunication ports .....		N/A
	b) EUT whose telecommunication ports have no reference to protective earth		N/A
<b>5.2</b>	<b>Electric strength</b> <i>EUT supplied by approved switching AC/DC adapter</i>		N/A
5.2.1	General		N/A
5.2.2	Test procedure		N/A
<b>5.3</b>	<b>Abnormal operating and fault conditions</b>		P
5.3.1	Protection against overload and abnormal operation	(see appended table 5.3)	P
5.3.2	Motors	Motors not used.	N/A
5.3.3	Transformers	Considered in approved external adapters.	N/A
5.3.4	Functional insulation .....	By short-circuited, results see appended table 5.3.	P
5.3.5	Electromechanical components	No electromechanical component.	N/A
5.3.6	Audio amplifiers in ITE .....		N/A
5.3.7	Simulation of faults	(see appended table 5.3.)	P
5.3.8	Unattended equipment	No such equipment.	N/A
5.3.9	Compliance criteria for abnormal operating and fault conditions		P
5.3.9.1	During the tests	No fire or molten metal occurred and no deformation of enclosure during the tests.	P
5.3.9.2	After the tests		N/A
<b>6</b>	<b>CONNECTION TO TELECOMMUNICATION NETWORKS</b>		N/A
<b>6.1</b>	<b>Protection of telecommunication network service persons, and users of other equipment connected to the network, from hazards in the equipment</b>		N/A

<b>IEC 60950-1</b>			
Clause	Requirement + Test	Result - Remark	Verdict
6.1.1	Protection from hazardous voltages		N/A
6.1.2	Separation of the telecommunication network from earth		N/A
6.1.2.1	Requirements		N/A
	Supply voltage (V) .....		—
	Current in the test circuit (mA) .....		—
6.1.2.2	Exclusions .....		N/A
<b>6.2</b>	<b>Protection of equipment users from overvoltages on telecommunication networks</b>		N/A
6.2.1	Separation requirements		N/A
6.2.2	Electric strength test procedure		N/A
6.2.2.1	Impulse test		N/A
6.2.2.2	Steady-state test		N/A
6.2.2.3	Compliance criteria		N/A
<b>6.3</b>	<b>Protection of the telecommunication wiring system from overheating</b>		N/A
	Max. output current (A) .....		—
	Current limiting method .....		—
<b>7</b>	<b>CONNECTION TO CABLE DISTRIBUTION SYSTEMS</b>		N/A
<b>7.1</b>	<b>General</b>		N/A
7.2	Protection of cable distribution system service persons, and users of other equipment connected to the system, from hazardous voltages in the equipment		N/A
7.3	Protection of equipment users from overvoltages on the cable distribution system		N/A
7.4	Insulation between primary circuits and cable distribution systems		N/A
7.4.1	General		N/A
7.4.2	Voltage surge test		N/A
7.4.3	Impulse test		N/A
<b>A</b>	<b>ANNEX A, TESTS FOR RESISTANCE TO HEAT AND FIRE</b>		N/A
<b>A.1</b>	<b>Flammability test for fire enclosures of movable equipment having a total mass exceeding 18 kg, and of stationary equipment (see 4.7.3.2)</b>		N/A
A.1.1	Samples.....		—
	Wall thickness (mm).....		—

<b>IEC 60950-1</b>			
Clause	Requirement + Test	Result - Remark	Verdict
A.1.2	Conditioning of samples; temperature (°C) .....		N/A
A.1.3	Mounting of samples .....		N/A
A.1.4	Test flame (see IEC 60695-11-3)		N/A
	Flame A, B, C or D .....		—
A.1.5	Test procedure		N/A
A.1.6	Compliance criteria		N/A
	Sample 1 burning time (s) .....		—
	Sample 2 burning time (s) .....		—
	Sample 3 burning time (s) .....		—
<b>A.2</b>	<b>Flammability test for fire enclosures of movable equipment having a total mass not exceeding 18 kg, and for material and components located inside fire enclosures (see 4.7.3.2 and 4.7.3.4)</b>		N/A
A.2.1	Samples, material .....		—
	Wall thickness (mm) .....		—
A.2.2	Conditioning of samples; temperature (°C) .....		N/A
A.2.3	Mounting of samples .....		N/A
A.2.4	Test flame (see IEC 60695-11-4)		N/A
	Flame A, B or C .....		—
A.2.5	Test procedure		N/A
A.2.6	Compliance criteria		N/A
	Sample 1 burning time (s) .....		—
	Sample 2 burning time (s) .....		—
	Sample 3 burning time (s) .....		—
A.2.7	Alternative test acc. to IEC 60695-11-5, cl. 5 and 9		N/A
	Sample 1 burning time (s) .....		—
	Sample 2 burning time (s) .....		—
	Sample 3 burning time (s) .....		—
<b>A.3</b>	<b>Hot flaming oil test (see 4.6.2)</b>		N/A
A.3.1	Mounting of samples		N/A
A.3.2	Test procedure		N/A
A.3.3	Compliance criterion		N/A
<b>B</b>	<b>ANNEX B, MOTOR TESTS UNDER ABNORMAL CONDITIONS (see 4.7.2.2 and 5.3.2)</b>		N/A
<b>B.1</b>	<b>General requirements</b>		N/A
	Position .....		—
	Manufacturer .....		—

<b>IEC 60950-1</b>			
Clause	Requirement + Test	Result - Remark	Verdict
	Type .....		—
	Rated values .....		—
<b>B.2</b>	<b>Test conditions</b>		N/A
<b>B.3</b>	<b>Maximum temperatures</b>		N/A
<b>B.4</b>	<b>Running overload test</b>		N/A
<b>B.5</b>	<b>Locked-rotor overload test</b>		N/A
	Test duration (days) .....		—
	Electric strength test: test voltage (V) .....		—
<b>B.6</b>	<b>Running overload test for d.c. motors in secondary circuits</b>		N/A
B.6.1	General		N/A
B.6.2	Test procedure		N/A
B.6.3	Alternative test procedure		N/A
B.6.4	Electric strength test; test voltage (V) .....		N/A
<b>B.7</b>	<b>Locked-rotor overload test for d.c. motors in secondary circuits</b>		N/A
B.7.1	General		N/A
B.7.2	Test procedure		N/A
B.7.3	Alternative test procedure		N/A
B.7.4	Electric strength test; test voltage (V) .....		N/A
<b>B.8</b>	<b>Test for motors with capacitors</b>		N/A
<b>B.9</b>	<b>Test for three-phase motors</b>		N/A
<b>B.10</b>	<b>Test for series motors</b>		N/A
	Operating voltage (V) .....		—

<b>C</b>	<b>ANNEX C, TRANSFORMERS (see 1.5.4 and 5.3.3)</b> <i>EUT supplied by approved switching AC/DC adapter</i>		N/A
	Position .....		—
	Manufacturer .....		—
	Type .....		—
	Rated values .....		—
	Method of protection .....		—
<b>C.1</b>	<b>Overload test</b>		N/A
<b>C.2</b>	<b>Insulation</b>		N/A
	Protection from displacement of windings .....		N/A



<b>IEC 60950-1</b>			
Clause	Requirement + Test	Result - Remark	Verdict
<b>D</b>	<b>ANNEX D, MEASURING INSTRUMENTS FOR TOUCH-CURRENT TESTS (see 5.1.4)</b>		N/A
<b>D.1</b>	Measuring instrument		N/A
<b>D.2</b>	Alternative measuring instrument		N/A
<b>E</b>	<b>ANNEX E, TEMPERATURE RISE OF A WINDING (see 1.4.13)</b>		N/A
<b>F</b>	<b>ANNEX F, MEASUREMENT OF CLEARANCES AND CREEPAGE DISTANCES (see 2.10 and Annex G)</b>		N/A
<b>G</b>	<b>ANNEX G, ALTERNATIVE METHOD FOR DETERMINING MINIMUM CLEARANCES</b>		N/A
<b>G.1</b>	Clearances		N/A
G.1.1	General		N/A
G.1.2	Summary of the procedure for determining minimum clearances		N/A
<b>G.2</b>	<b>Determination of mains transient voltage (V)</b>		N/A
G.2.1	AC mains supply .....		N/A
G.2.2	Earthed d.c. mains supplies .....		N/A
G.2.3	Unearthed d.c. mains supplies .....		N/A
G.2.4	Battery operation .....		N/A
<b>G.3</b>	<b>Determination of telecommunication network transient voltage (V) .....</b>		N/A
<b>G.4</b>	<b>Determination of required withstand voltage (V)</b>		N/A
G.4.1	Mains transients and internal repetitive peaks .....		N/A
G.4.2	Transients from telecommunication networks .....		N/A
G.4.3	Combination of transients		N/A
G.4.4	Transients from cable distribution systems		N/A
<b>G.5</b>	<b>Measurement of transient voltages (V)</b>		N/A
	a) Transients from a mains supply		N/A
	For an a.c. mains supply		N/A
	For a d.c. mains supply		N/A
	b) Transients from a telecommunication network		N/A
<b>G.6</b>	<b>Determination of minimum clearances .....</b>		N/A
<b>H</b>	<b>ANNEX H, IONIZING RADIATION (see 4.3.13)</b>		N/A
<b>J</b>	<b>ANNEX J, TABLE OF ELECTROCHEMICAL POTENTIALS (see 2.6.5.6)</b>		N/A

IEC 60950-1			
Clause	Requirement + Test	Result - Remark	Verdict

	Metal(s) used .....		—
--	---------------------	--	---

<b>K</b>	<b>ANNEX K, THERMAL CONTROLS (see 1.5.3 and 5.3.8)</b>		N/A
K.1	Making and breaking capacity		N/A
K.2	Thermostat reliability; operating voltage (V) .....		N/A
K.3	Thermostat endurance test; operating voltage (V) .....		N/A
K.4	Temperature limiter endurance; operating voltage (V) .....		N/A
K.5	Thermal cut-out reliability		N/A
K.6	Stability of operation		N/A

<b>L</b>	<b>ANNEX L, NORMAL LOAD CONDITIONS FOR SOME TYPES OF ELECTRICAL BUSINESS EQUIPMENT (see 1.2.2.1 and 4.5.2)</b>		P
L.1	Typewriters		N/A
L.2	Adding machines and cash registers		N/A
L.3	Erasers		N/A
L.4	Pencil sharpeners		N/A
L.5	Duplicators and copy machines		N/A
L.6	Motor-operated files		N/A
L.7	Other business equipment	See 1.6.2.	P

<b>M</b>	<b>ANNEX M, CRITERIA FOR TELEPHONE RINGING SIGNALS (see 2.3.1)</b>		N/A
M.1	Introduction		N/A
M.2	Method A		N/A
M.3	Method B		N/A
M.3.1	Ringling signal		N/A
M.3.1.1	Frequency (Hz) .....		—
M.3.1.2	Voltage (V) .....		—
M.3.1.3	Cadence; time (s), voltage (V) .....		—
M.3.1.4	Single fault current (mA) .....		—
M.3.2	Tripping device and monitoring voltage .....		N/A
M.3.2.1	Conditions for use of a tripping device or a monitoring voltage		N/A
M.3.2.2	Tripping device		N/A
M.3.2.3	Monitoring voltage (V) .....		N/A

<b>IEC 60950-1</b>			
Clause	Requirement + Test	Result - Remark	Verdict
<b>N</b>	<b>ANNEX N, IMPULSE TEST GENERATORS (see 1.5.7.2, 1.5.7.3, 2.10.3.9, 6.2.2.1, 7.3.2, 7.4.3 and Clause G.5)</b>		N/A
N.1	ITU-T impulse test generators		N/A
N.2	IEC 60065 impulse test generator		N/A
<b>P</b>	<b>ANNEX P, NORMATIVE REFERENCES</b>		—
<b>Q</b>	<b>ANNEX Q, Voltage dependent resistors (VDRs) (see 1.5.9.1)</b>		N/A
	- Preferred climatic categories .....		N/A
	- Maximum continuous voltage .....		N/A
	- Combination pulse current .....		N/A
	Body of the VDR Test according to IEC60695-11-5 .....		N/A
	Body of the VDR. Flammability class of material ( min V-1) .....		N/A
<b>R</b>	<b>ANNEX R, EXAMPLES OF REQUIREMENTS FOR QUALITY CONTROL PROGRAMMES</b>		N/A
R.1	Minimum separation distances for unpopulated coated printed boards (see 2.10.6.2)		N/A
R.2	Reduced clearances (see 2.10.3)		N/A
<b>S</b>	<b>ANNEX S, PROCEDURE FOR IMPULSE TESTING (see 6.2.2.3)</b>		N/A
S.1	Test equipment		N/A
S.2	Test procedure		N/A
S.3	Examples of waveforms during impulse testing		N/A
<b>T</b>	<b>ANNEX T, GUIDANCE ON PROTECTION AGAINST INGRESS OF WATER (see 1.1.2)</b>		N/A
			—
<b>U</b>	<b>ANNEX U, INSULATED WINDING WIRES FOR USE WITHOUT INTERLEAVED INSULATION (see 2.10.5.4)</b>		N/A
			—
<b>V</b>	<b>ANNEX V, AC POWER DISTRIBUTION SYSTEMS (see 1.6.1)</b>		N/A
V.1	Introduction		N/A
V.2	TN power distribution systems		N/A

<b>IEC 60950-1</b>			
Clause	Requirement + Test	Result - Remark	Verdict
<b>W</b>	<b>ANNEX W, SUMMATION OF TOUCH CURRENTS</b>		N/A
W.1	Touch current from electronic circuits		N/A
W.1.1	Floating circuits		N/A
W.1.2	Earthed circuits		N/A
W.2	Interconnection of several equipments		N/A
W.2.1	Isolation		N/A
W.2.2	Common return, isolated from earth		N/A
W.2.3	Common return, connected to protective earth		N/A
<b>X</b>	<b>ANNEX X, MAXIMUM HEATING EFFECT IN TRANSFORMER TESTS (see clause C.1)</b>		N/A
X.1	Determination of maximum input current		N/A
X.2	Overload test procedure		N/A
<b>Y</b>	<b>ANNEX Y, ULTRAVIOLET LIGHT CONDITIONING TEST (see 4.3.13.3)</b>		N/A
Y.1	Test apparatus .....		N/A
Y.2	Mounting of test samples .....		N/A
Y.3	Carbon-arc light-exposure apparatus .....		N/A
Y.4	Xenon-arc light exposure apparatus .....		N/A
<b>Z</b>	<b>ANNEX Z, OVERVOLTAGE CATEGORIES (see 2.10.3.2 and Clause G.2)</b>		P
<b>AA</b>	<b>ANNEX AA, MANDREL TEST (see 2.10.5.8)</b>		N/A
<b>BB</b>	<b>ANNEX BB, CHANGES IN THE SECOND EDITION</b>		—
<b>CC</b>	<b>ANNEX CC, Evaluation of integrated circuit (IC) current limiters</b>		N/A
CC.1	General		N/A
CC.2	Test program 1 .....		N/A
CC.3	Test program 2 .....		N/A
CC.4	Test program 3 .....		N/A
CC.5	Compliance .....		N/A
<b>DD</b>	<b>ANNEX DD, Requirements for the mounting means of rack-mounted equipment</b>		N/A
DD.1	General		N/A
DD.2	Mechanical strength test, variable N.....		N/A

<b>IEC 60950-1</b>			
Clause	Requirement + Test	Result - Remark	Verdict
DD.3	Mechanical strength test, 250 N, including end stops.....:		N/A
DD.4	Compliance.....:		N/A

<b>EE</b>	<b>ANNEX EE, Household and home/office document/media shredders</b>		N/A
EE.1	General		N/A
EE.2	Markings and instructions		N/A
	Use of markings or symbols.....:		N/A
	Information of user instructions, maintenance and/or servicing instructions.....:		N/A
EE.3	Inadvertent reactivation test.....:		N/A
EE.4	Disconnection of power to hazardous moving parts:		N/A
	Use of markings or symbols.....:		N/A
EE.5	Protection against hazardous moving parts		N/A
	Test with test finger (Figure 2A) .....		N/A
	Test with wedge probe (Figure EE1 and EE2) .....		N/A

IEC 60950-1					
Clause	Requirement + Test			Result - Remark	Verdict
1.5.1	TABLE: list of critical components				<b>P</b>
Object/part no.	Manufacture/ trademark	Type/model	Technical data	standard	Mark(s) of conformity <sup>1)</sup>
LCD Panel	AUO	M270DTN**.* (* can be 0-9, A-Z, a-z, "-" or blank)	27 inch panel with LED backlight  The declared power consumption is 33.7W and backlight input voltage is 56.7V in specification.	--	Tested in equipment
	AUO	M270DAN**** (* can be 0-9, A-Z, a-z, "-" or blank)	27 inch panel with LED backlight  The declared power consumption is 28.5W and backlight input voltage is 57.8V in specification.	--	Tested in equipment
	TPV	TPM270W** (* can be 0-9, A-Z, a-z, "-" or blank)	27 inch panel with LED backlight  The declared power consumption is 21.3W and backlight input voltage is 38.4V in specification.	--	Tested in equipment
	SAMSUNG	LTM270DL** (* can be 0-9, A-Z, a-z, "-" or blank)	27 inch panel with LED backlight  The declared power consumption is 30.84W and backlight input voltage is 52.8V in specification.	--	Tested in equipment
	LG Display	LM270W** (* can be 0-9, A-Z, a-z, "-" or blank)	27 inch panel with LED backlight  The declared power consumption is 28.3W and backlight input voltage is 54.7V in specification.	--	Tested in equipment

IEC 60950-1					
Clause	Requirement + Test		Result - Remark		Verdict
Plastic Enclosure	SDI CHEMICAL CO LTD	SD-0150(+), VH-0810(+), VE-0812(+), NH-1000T(+)(&), GC-0700(+++), GC-1017(+), GC-0750(+), VE-1890(+), TN-1100(+), BF-0675(+), BF-0670(+), NH-1017SG(+), NH-1017(p), NE-1030(+), BF-0677(+), HS-7000(+), HG-0760(+), HR-1360(+)	HB or better, thickness 2.0mm min.	UL 94	UL (E115797)
	Grand	D-150, D-1000A D-1000	HB or better, thickness 2.0mm min.	UL 94	UL (E88637)
	Chi Mei	PA-757(+), PH-88, PA-756S	HB or better, thickness 2.0mm min.	UL 94	UL (E56070)
	ALBIS	GP-35, GP-22, 495F	HB or better, thickness 2.0mm min.	UL 94	UL (E80168)
	WISTRON	GA35	HB or better, thickness 2.0mm min.	UL 94	UL (E359575)
	Bayer	FR3000 series, FR3005 series	HB or better, thickness 2.0mm min.	UL 94	UL (E41613)
	LG	HF350(#), HF-380(#), AF312T1, AF342T1, AF342(#), LUPOY GN- 5001TF(#), GN-5001RFD, LUPOY GN- 5008HF(#), SE750(#), XG568(#), XG569(#), GP-1000F(#), LUPOY GN- 5001RF(T),	HB or better, thickness 2.0mm min.	UL 94	UL (E67171)

IEC 60950-1					
Clause	Requirement + Test			Result - Remark	Verdict
	Teijin	TN-7500(c), TN-7500F(#) MN-3600H(#) MN-3600V(#)	HB or better, thickness 2.0mm min.	UL 94	UL (E98529, E244324)
	HINGLONG	HL-ABS-PCR85; HL-ABS-PCR65	HB or better, thickness 2.0mm min.	UL 94	UL (E345434)
	STYRON	STYRON A-TECH 1400	HB or better, thickness 2.0mm min.	UL 94	UL (E73656)
	KingFa	5197, HIPS-5197, HF-606, HF-626, FRABS-518, GAR-011C, JH960 6(M), FRHIPS-960, RS-900, RS-300, RS-400, GAR-011(L65), GAR-011(L85) GAR-011(HG6), CK-100, HIPS-510 (o)	HB or better, thickness 2.0mm min.	UL 94	UL (E171666)
	Haier	HRABS-RS, HRABS-HG, CR-3002	HB or better, thickness 2.0mm min.	UL 94	UL (E230779)
	ORINKO	ABS-3070H, HIPS-2000	HB or better, thickness 2.0mm min.	UL 94	UL (E328304)
	GUO HENG (DONGGUAN)	YOUHO(####)(Y), YOUHO(1302)(B), YOUHO(1303)(B)	HB or better, thickness 2.0mm min.	UL 94	UL (E471190)
	WOTE ADVANCED	2100	HB or better, thickness 2.0mm min.	UL 94	UL (E310240)
	SABIC	C6600	HB or better, thickness 2.0mm min.	UL 94	UL (E207780)
	Interchangeable	Interchangeable	HB or better, thickness 2.0mm min.	UL 94	UL
Metal enclosure	Interchangeable	Interchangeable	Metal thickness: min. 0.4mm	--	--
PCB	Interchangeable	Interchangeable	V-1 or better, min. 105°C, thickness: 1.50mm	UL 94, UL 796	UL
Base stand	Interchangeable	Interchangeable	HB or better	UL 94	UL



IEC 60950-1					
Clause	Requirement + Test			Result - Remark	Verdict
AC/DC Adapter	TPV	ADPC20120	Input: 100-240Vac, 50-60Hz, 1.5A Output: 20Vdc, 6.0A	IEC 60950-1:2005 (Second Edition) + Am 1:2009 + Am 2:2013	TUV CB (Certif. No. JPTUV-055597/A1)
Note(s):					
1. An asterisk indicates a mark that assures the agreed level of surveillance.					

1.6.2	TABLE: electrical data (in normal conditions)						P
U (V)	I (A)	I <sub>rated</sub> (A)	P (W)	Fuse #	I <sub>fuse</sub> (A)	Condition/status	
<b>Tested with main board 715G8055</b>							
VGA mode							
20.1	3.53	6.0	70.9	--	--	Maximum normal load	
DVI mode							
20.1	3.55	6.0	71.2	--	--	Maximum normal load	
HDMI mode							
20.1	3.61	6.0	72.4	--	--	Maximum normal load	
HDMI with MHL mode							
20.2	3.38	6.0	68.2	--	--	Maximum normal load	
DisplayPort mode							
20.9	3.59	6.0	72.1	--	--	Maximum normal load	
<b>Tested with main board 715G8083</b>							
DisplayPort mode							
20.2	3.34	6.0	67.3	--	--	Maximum normal load	
HDMI mode							
20.1	3.35	6.0	67.4	--	--	Maximum normal load	
Note(s):							
1. Maximum normal load: maximum brightness, maximum contrast, full white screen, optimal resolution, each USB 3.0 port loaded with 5V/0.9A, HDMI with MHL port loaded 5V/1.5A (if any).							

2.2.2	TABLE: Hazardous voltage measurement			P
Component (measured between)	max. voltage (V) (normal operation)		Voltage Limiting Components	
	V peak	V d.c.		
<b>Tested with main board 715G8055</b>				
Converter circuit CN804 Pin 3,4 output to panel LED backlight	--	57.1	--	

IEC 60950-1			
Clause	Requirement + Test	Result - Remark	Verdict

**Tested with main board 715G8083**

Converter circuit CN801 Pin 3,4 output to panel LED backlight	--	56.8	--
Supplementary information: Input Voltage is 20Vdc.			

4.5	TABLE: Thermal requirements			P
	Supply voltage (V) .....	20Vdc	--	—
	Ambient $T_{min}$ (°C) .....	See below	--	—
	Ambient $T_{max}$ (°C) .....	See below	--	—
Maximum measured temperature T of part/at.....:		T (°C)		Allowed $T_{max}$ (°C)

**Tested with main board 715G8055**

DC inlet body CN701 (on main board)	39.5	--	54.4
PCB near L981 (on main board)	58.3	--	89.4
PCB near L801 (on main board)	48.6	--	89.4
PCB near C801 (on main board)	47.8	--	89.4
PCB near U801 (on main board)	59.5	--	89.4
PCB near U401 (on main board)	53.6	--	89.4
Plastic enclosure inside	40.6	--	--
Plastic enclosure outside	33.4	--	79.4
Metal	39.3		--
Panel surface	38.5	--	79.4
Ambient	24.4	--	--

**Tested with main board 715G8083**

DC inlet body CN701 (on main board)	37.5	--	55.1
PCB near L981 (on main board)	56.8	--	90.1
PCB near L801 (on main board)	47.6	--	90.1
PCB near C801 (on main board)	47.3	--	90.1
PCB near U801 (on main board)	54.7	--	90.1
PCB near U401 (on main board)	52.5	--	90.1
Plastic enclosure inside	39.7	--	--
Plastic enclosure outside	29.4	--	80.1

IEC 60950-1			
Clause	Requirement + Test	Result - Remark	Verdict

Metal	38.6	--	--
Panel surface	37.8	--	80.1
Ambient	25.1	--	--

**Supplementary information:**

- The temperatures were measured under the worse case normal mode defined in 1.2.2.1 and as described in sub-clause 1.6.2 at voltages as described above.
- With a specified ambient temperature of 40°C, and the minimum ambient temperature during test  $T_{amb}$ , Temperature is calculated as follows:
  - $T_{max} = T_{max \text{ of component}} - 40 + T_{amb}$ .

Temperature T of winding:	$t_1$ (°C)	$R_1$ (Ω)	$t_2$ (°C)	$R_2$ (Ω)	T (°C)	Allowed $T_{max}$ (°C)	Insulation class

**Supplementary information:**

4.6.1, 4.6.2	Table: enclosure openings	P
Location	Size (mm)	Comments
<b>Metal enclosure under components (L981, C991, C983) before fuse</b>		
Bottom	No opening	--
<b>Supplementary information:</b>		

5.3	TABLE: Fault condition tests						P
	Ambient temperature (°C) .....						---
	Power source for EUT: Manufacturer, model/type, output rating .....						---
Component No.	Fault	Supply voltage (V)	Test time	Fuse #	Fuse current (A)	Observation	
<b>Tested with main board 715G8055</b>							
D801	s-c	20Vdc	5 min	--	--	Unit shut down, no hazard.	
L801	s-c	20Vdc	5 min	--	--	Unit shut down, no hazard.	
C801	s-c	20Vdc	5 min	--	--	Unit shut down, no hazard.	
C809	s-c	20Vdc	5 min	--	--	Unit shut down, no hazard.	
Converter output to earth	s-c	20Vdc	5 min	--	--	Unit shut down, no hazard.	
<b>Tested with main board 715G8083</b>							
D801	s-c	20Vdc	5 min	--	--	Unit shut down, no hazard.	

IEC 60950-1						
Clause	Requirement + Test				Result - Remark	Verdict
L801	s-c	20Vdc	5 min	--	--	Unit shut down, no hazard.
C801	s-c	20Vdc	5 min	--	--	Unit shut down, no hazard.
C809	s-c	20Vdc	5 min	--	--	Unit shut down, no hazard.
Converter output to earth	s-c	20Vdc	5 min	--	--	Unit shut down, no hazard.
<b>Supplementary information:</b>						
1. In fault column, where s-c=short-circuited.						

IEC60950_1F - ATTACHMENT			
Clause	Requirement + Test	Result - Remark	Verdict

<b>ATTACHMENT TO TEST REPORT IEC 60950-1</b> <b>EUROPEAN GROUP DIFFERENCES AND NATIONAL DIFFERENCES</b> Information technology equipment – Safety – Part 1: General requirements			
<b>Differences according to</b> .....: EN 60950-1:2006/A11:2009/A1:2010/A12:2011/A2:2013			
<b>Attachment Form No.</b> ....: EU_GD_IEC60950_1F			
<b>Attachment Originator</b> .....: SGS Fimko Ltd			
<b>Master Attachment</b> .....: Date 2014-02			
<b>Copyright © 2014 IEC System for Conformity Testing and Certification of Electrical Equipment (IECEE), Geneva, Switzerland. All rights reserved.</b>			

EN 60950-1:2006/A11:2009/A1:2010/A12:2011/A2:2013 – CENELEC COMMON MODIFICATIONS			
--	--	--	--

IEC 60950-1, GROUP DIFFERENCES (CENELEC common modifications EN)			
Clause	Requirement + Test	Result - Remark	Verdict
	Clauses, subclauses, notes, tables and figures which are additional to those in IEC60950-1 and it's amendmets are prefixed "Z"		<b>P</b>
Contents  (A2:2013)	Add the following annexes: Annex ZA (normative)  Annex ZB (normative) Annex ZD (informative)	Normative references to international publications with their corresponding European publications  Special national conditions IEC and CENELEC code designations for flexible cords	<b>P</b>
General	Delete all the "country" notes in the reference document (IEC 60950-1:2005) according to the following list: 1.4.8 Note 2      1.5.1      Note 2 & 3      1.5.7.1      Note 1.5.8 Note 2      1.5.9.4      Note      1.7.2.1      Note 4, 5 & 6 2.2.3 Note      2.2.4      Note      2.3.2      Note 2.3.2.1 Note 2      2.3.4      Note 2      2.6.3.3      Note 2 & 3 2.7.1 Note      2.10.3.2      Note 2      2.10.5.13      Note 3 3.2.1.1 Note      3.2.4      Note 3.      2.5.1      Note 2 4.3.6 Note 1 & 2      4.7      Note 4      4.7.2.2      Note 4.7.3.1Note 2      5.1.7.1      Note 3 & 4      5.3.7      Note 1 6 Note 2 & 5      6.1.2.1      Note 2      6.1.2.2      Note 6.2.2 Note      6.2.2.1      Note 2      6.2.2.2      Note 7.1 Note 3      7.2      Note      7.3      Note 1 & 2 G.2.1 Note 2      Annex H      Note 2		<b>P</b>
General (A1:2010)	Delete all the "country" notes in the reference document (IEC 60950-1:2005/A1:2010) according to the following list: 1.5.7.1 Note      6.1.2.1 Note 2 6.2.2.1 Note 2      EE.3 Note		<b>P</b>

IEC60950_1F - ATTACHMENT			
Clause	Requirement + Test	Result - Remark	Verdict
<b>IEC 60950-1, GROUP DIFFERENCES (CENELEC common modifications EN)</b>			
Clause	Requirement + Test	Result - Remark	Verdict
General (A2:2013)	Delete all the "country" notes in the reference document (IEC 60950-1:2005/A2:2013) according to the following list: 2.7.1 Note *                      2.10.3.1 Note 2 6.2.2. Note * Note of secretary: Text of Common Modification remains unchanged.		<b>P</b>
1.1.1 (A1:2010)	<b>Replace</b> the text of NOTE 3 by the following. NOTE 3 The requirements of EN 60065 may also be used to meet safety requirements for multimedia equipment. See IEC Guide 112, Guide on the safety of multimedia equipment. For television sets EN 60065 applies.		<b>P</b>
1.3.Z1	Add the following subclause: 1.3.Z1 Exposure to excessive sound pressure The apparatus shall be so designed and constructed as to present no danger when used for its intended purpose, either in normal operating conditions or under fault conditions, particularly providing protection against exposure to excessive sound pressures from headphones or earphones. NOTE Z1 A new method of measurement is described in EN 50332-1, Sound system equipment: Headphones and earphones associated with portable audio equipment - Maximum sound pressure level measurement methodology and limit considerations - Part 1: General method for "one package equipment", and in EN 50332-2, Sound system equipment: Headphones and earphones associated with portable audio equipment - Maximum sound pressure level measurement methodology and limit considerations - Part 2: Guidelines to associate sets with headphones coming from different manufacturers.	Added.	<b>N/A</b>
(A12:2011)	In EN 60950-1:2006/A12:2011 Delete the addition of 1.3.Z1 / EN 60950-1:2006 Delete the definition 1.2.3.Z1 / EN 60950-1:2006 /A1:2010	Deleted.	<b>N/A</b>
1.5.1  (Added info*)	Add the following NOTE: NOTE Z1 The use of certain substances in electrical and electronic equipment is restricted within the EU: see Directive 2002/95/EC. New Directive 2011/65/11 *		<b>N/A</b>
1.7.2.1 (A1:2010)	In addition, for a PORTABLE SOUND SYSTEM, the instructions shall include a warning that excessive sound pressure from earphones and headphones can cause hearing loss.	Added.	<b>N/A</b>
1.7.2.1 (A12:2011)	In EN 60950-1:2006/A12:2011 Delete NOTE Z1 and the addition for Portable Sound System. Add the following clause and annex to the existing standard and amendments.		<b>N/A</b>

IEC60950_1F - ATTACHMENT			
Clause	Requirement + Test	Result - Remark	Verdict

IEC 60950-1, GROUP DIFFERENCES (CENELEC common modifications EN)			
Clause	Requirement + Test	Result - Remark	Verdict
	<b>Zx Protection against excessive sound pressure from personal music players</b>		<b>N/A</b>
	<p><b>Zx.1 General</b></p> <p>This sub-clause specifies requirements for protection against excessive sound pressure from personal music players that are closely coupled to the ear. It also specifies requirements for earphones and headphones intended for use with personal music players.</p> <p>A personal music player is a portable equipment□ for personal use, that:</p> <ul style="list-style-type: none"> <li>– is designed to allow the user to listen to recorded or broadcast sound or video; and</li> <li>– primarily uses headphones or earphones that can be worn in or on or around the ears; and</li> <li>– allows the user to walk around while in use.</li> </ul> <p>NOTE 1 Examples are hand-held or body-worn portable CD players, MP3 audio players, mobile phones with MP3 type features, PDA's or similar equipment.</p> <p>A personal music player and earphones or headphones intended to be used with personal music players shall comply with the requirements of this sub-clause.</p> <p>The requirements in this sub-clause are valid for music or video mode only.</p> <p>The requirements do not apply:</p> <ul style="list-style-type: none"> <li>– while the personal music player is connected to an external amplifier; or</li> <li>– while the headphones or earphones are not used.</li> </ul> <p>NOTE 2 An external amplifier is an amplifier which is not part of the personal music player or the listening device, but which is intended to play the music as a standalone music player.</p> <p>The requirements do not apply to:</p> <ul style="list-style-type: none"> <li>– hearing aid equipment and professional equipment;</li> </ul> <p>NOTE 3 Professional equipment is equipment sold through special sales channels. All products sold through normal electronics stores are considered not to be professional equipment.</p>	Not personal music player.	<b>N/A</b>

IEC60950_1F - ATTACHMENT			
Clause	Requirement + Test	Result - Remark	Verdict

IEC 60950-1, GROUP DIFFERENCES (CENELEC common modifications EN)			
Clause	Requirement + Test	Result - Remark	Verdict
	<p>– analogue personal music players (personal music players without any kind of digital processing of the sound signal) that are brought to the market before the end of 2015.</p> <p>NOTE 4 This exemption has been allowed because this technology is falling out of use and it is expected that within a few years it will no longer exist. This exemption will not be extended to other technologies.</p> <p>For equipment which is clearly designed or intended for use by young children, the limits of EN 71-1 apply.</p>		
	<p><b>Zx.2 Equipment requirements</b></p> <p>No safety provision is required for equipment that complies with the following:</p> <ul style="list-style-type: none"> <li>– equipment provided as a package (personal music player with its listening device), where the acoustic output <math>L_{Aeq,T}</math> is <math>\leq 85</math> dBA measured while playing the fixed “programme simulation noise” as described in EN 50332-1; and</li> <li>– a personal music player provided with an analogue electrical output socket for a listening device, where the electrical output is <math>\leq 27</math> mV measured as described in EN 50332-2, while playing the fixed “programme simulation noise” as described in EN 50332-1.</li> </ul> <p>NOTE 1 Wherever the term acoustic output is used in this clause, the 30 s A-weighted equivalent sound pressure level <math>L_{Aeq,T}</math> is meant. See also Zx.5 and Annex Zx.</p> <p>All other equipment shall:</p> <ol style="list-style-type: none"> <li>a) protect the user from unintentional acoustic outputs exceeding those mentioned above; and</li> <li>b) have a standard acoustic output level not exceeding those mentioned above, and automatically return to an output level not exceeding those mentioned above when the power is switched off; and</li> </ol>	Not such equipment.	<b>N/A</b>



IEC60950_1F - ATTACHMENT			
Clause	Requirement + Test	Result - Remark	Verdict

IEC 60950-1, GROUP DIFFERENCES (CENELEC common modifications EN)			
Clause	Requirement + Test	Result - Remark	Verdict
	<p>c) provide a means to actively inform the user of the increased sound pressure when the equipment is operated with an acoustic output exceeding those mentioned above. Any means used shall be acknowledged by the user before activating a mode of operation which allows for an acoustic output exceeding those mentioned above. The acknowledgement does not need to be repeated more than once every 20 h of cumulative listening time; and</p> <p>NOTE 2 Examples of means include visual or audible signals. Action from the user is always required.</p> <p>NOTE 3 The 20 h listening time is the accumulative listening time, independent how often and how long the personal music player has been switched off.</p> <p>d) have a warning as specified in Zx.3; and</p> <p>e) not exceed the following:</p> <ol style="list-style-type: none"> <li>1) equipment provided as a package (player with its listening device), the acoustic output shall be <math>\leq 100</math> dBA measured while playing the fixed "programme simulation noise" described in EN 50332-1; and</li> <li>2) a personal music player provided with an analogue electrical output socket for a listening device, the electrical output shall be <math>\leq 150</math> mV measured as described in EN 50332-2, while playing the fixed "programme simulation noise" described in EN 50332-1.</li> </ol> <p>For music where the average sound pressure (long term <math>L_{Aeq,T}</math>) measured over the duration of the song is lower than the average produced by the programme simulation noise, the warning does not need to be given as long as the average sound pressure of the song is below the basic limit of 85 dBA. In this case T becomes the duration of the song.</p> <p>NOTE 4 Classical music typically has an average sound pressure (long term <math>L_{Aeq,T}</math>) which is much lower than the average programme simulation noise. Therefore, if the player is capable to analyse the song and compare it with the programme simulation noise, the warning does not need to be given as long as the average sound pressure of the song is below the basic limit of 85 dBA.</p> <p>For example, if the player is set with the programme simulation noise to 85 dBA, but the average music level of the song is only 65 dBA, there is no need to give a warning or ask an acknowledgement as long as the average sound level of the song is not above the basic limit of 85 dBA.</p>		

IEC60950_1F - ATTACHMENT			
Clause	Requirement + Test	Result - Remark	Verdict

IEC 60950-1, GROUP DIFFERENCES (CENELEC common modifications EN)			
Clause	Requirement + Test	Result - Remark	Verdict
	<p><b>Zx.3 Warning</b></p> <p>The warning shall be placed on the equipment, or on the packaging, or in the instruction manual and shall consist of the following:</p> <ul style="list-style-type: none"> <li>– the symbol of Figure 1 with a minimum height of 5 mm; and</li> <li>– the following wording, or similar:</li> </ul> <p>“To prevent possible hearing damage, do not listen at high volume levels for long periods.”</p> <div style="text-align: center;">  </div> <p><b>Figure 1 – Warning label (IEC 60417-6044)</b></p> <p>Alternatively, the entire warning may be given through the equipment display during use, when the user is asked to acknowledge activation of the higher level.</p>	Not such equipment	<b>N/A</b>
	<p><b>Zx.4 Requirements for listening devices (headphones and earphones)</b></p>		<b>N/A</b>
	<p><b>Zx.4.1 Wired listening devices with analogue input</b></p> <p>With 94 dBA sound pressure output <math>L_{Aeq,T}</math>, the input voltage of the fixed “programme simulation noise” described in EN 50332-2 shall be <math>\geq 75</math> mV.</p> <p>This requirement is applicable in any mode where the headphones can operate (active or passive), including any available setting (for example built-in volume level control).</p> <p>NOTE The values of 94 dBA – 75 mV correspond with 85dBA – 27 mV and 100 dBA – 150 mV.</p>	Not such equipment	<b>N/A</b>

IEC60950_1F - ATTACHMENT			
Clause	Requirement + Test	Result - Remark	Verdict
<b>IEC 60950-1, GROUP DIFFERENCES (CENELEC common modifications EN)</b>			
Clause	Requirement + Test	Result - Remark	Verdict
	<p><b>Zx.4.2 Wired listening devices with digital input</b></p> <p>With any playing device playing the fixed “programme simulation noise” described in EN 50332-1 (and respecting the digital interface standards, where a digital interface standard exists that specifies the equivalent acoustic level), the acoustic output <math>L_{Aeq,T}</math> of the listening device shall be <math>\leq 100</math> dBA.</p> <p>This requirement is applicable in any mode where the headphones can operate, including any available setting (for example built-in volume level control, additional sound feature like equalization, etc.).</p> <p>NOTE An example of a wired listening device with digital input is a USB headphone.</p>	Not such equipment	N/A
	<p><b>Zx.4.3 Wireless listening devices</b></p> <p>In wireless mode:</p> <ul style="list-style-type: none"> <li>– with any playing and transmitting device playing the fixed programme simulation noise described in EN 50332-1; and</li> <li>– respecting the wireless transmission standards, where an air interface standard exists that specifies the equivalent acoustic level; and</li> <li>– with volume and sound settings in the listening device (for example built-in volume level control, additional sound feature like equalization, etc.) set to the combination of positions that maximize the measured acoustic output for the abovementioned programme simulation noise, the acoustic output <math>L_{Aeq,T}</math> of the listening device shall be <math>\leq 100</math> dBA.</li> </ul> <p>NOTE An example of a wireless listening device is a Bluetooth headphone.</p>	Not such equipment	N/A
	<p><b>Zx.5 Measurement methods</b></p> <p>Measurements shall be made in accordance with EN 50332-1 or EN 50332-2 as applicable. Unless stated otherwise, the time interval T shall be 30 s.</p> <p>NOTE Test method for wireless equipment provided without listening device should be defined.</p>	Not such equipment	N/A

IEC60950_1F - ATTACHMENT			
Clause	Requirement + Test	Result - Remark	Verdict

<b>IEC 60950-1, GROUP DIFFERENCES (CENELEC common modifications EN)</b>									
Clause	Requirement + Test	Result - Remark	Verdict						
2.7.1	<p>Replace the subclause as follows:</p> <p>Basic requirements</p> <p>To protect against excessive current, short-circuits and earth faults in PRIMARY CIRCUITS, protective devices shall be included either as integral parts of the equipment or as parts of the building installation, subject to the following, a), b) and c):</p> <p>a) except as detailed in b) and c), protective devices necessary to comply with the requirements of 5.3 shall be included as parts of the equipment;</p> <p>b) for components in series with the mains input to the equipment such as the supply cord, appliance coupler, r.f.i. filter and switch, short-circuit and earth fault protection may be provided by protective devices in the building installation;</p>	Replaced.	<b>N/A</b>						
	<p>c) it is permitted for PLUGGABLE EQUIPMENT TYPE B or PERMANENTLY CONNECTED EQUIPMENT, to rely on dedicated overcurrent and short-circuit protection in the building installation, provided that the means of protection, e.g. fuses or circuit breakers, is fully specified in the installation instructions.</p> <p>If reliance is placed on protection in the building installation, the installation instructions shall so state, except that for PLUGGABLE EQUIPMENT TYPE A the building installation shall be regarded as providing protection in accordance with the rating of the wall socket outlet.</p>	No such equipment	<b>N/A</b>						
2.7.2	This subclause has been declared 'void'.		<b>N/A</b>						
3.2.3	Delete the NOTE in Table 3A, and delete also in this table the conduit sizes in parentheses.		<b>N/A</b>						
3.2.5.1	<p>Replace "60245 IEC 53" by "H05 RR-F";</p> <p>"60227 IEC 52" by "H03 VV-F or H03 VVH2-F";</p> <p>"60227 IEC 53" by "H05 VV-F or H05 VVH2-F2".</p> <p>In Table 3B, replace the first four lines by the following:</p> <table style="margin-left: 40px;"> <tr> <td>Up to and including 6  </td> <td>0,75 <sup>a)</sup>  </td> </tr> <tr> <td>Over 6 up to and including 10  </td> <td>(0,75) <sup>b)</sup> 1,0  </td> </tr> <tr> <td>Over 10 up to and including 16  </td> <td>(1,0) <sup>c)</sup> 1,5  </td> </tr> </table> <p>In the conditions applicable to Table 3B delete the words "in some countries" in condition <sup>a)</sup>.</p> <p>In NOTE 1, applicable to Table 3B, delete the second sentence.</p>	Up to and including 6	0,75 <sup>a)</sup>	Over 6 up to and including 10	(0,75) <sup>b)</sup> 1,0	Over 10 up to and including 16	(1,0) <sup>c)</sup> 1,5		<b>N/A</b>
Up to and including 6	0,75 <sup>a)</sup>								
Over 6 up to and including 10	(0,75) <sup>b)</sup> 1,0								
Over 10 up to and including 16	(1,0) <sup>c)</sup> 1,5								
3.2.5.1 (A2:2013)	NOTE Z1 The harmonised code designations corresponding to the IEC cord types are given in Annex ZD		<b>N/A</b>						

IEC60950_1F - ATTACHMENT			
Clause	Requirement + Test	Result - Remark	Verdict

<b>IEC 60950-1, GROUP DIFFERENCES (CENELEC common modifications EN)</b>			
Clause	Requirement + Test	Result - Remark	Verdict
3.3.4	In Table 3D, delete the fourth line: conductor sizes for 10 to 13 A, and replace with the following: Over 10 up to and including 16   1,5 to 2,5   1,5 to 4   Delete the fifth line: conductor sizes for 13 to 16 A		<b>N/A</b>
4.3.13.6 (A1:2010)	Replace the existing NOTE by the following: NOTE Z1 Attention is drawn to: 1999/519/EC: Council Recommendation on the limitation of exposure of the general public to electromagnetic fields 0 Hz to 300 GHz, and 2006/25/EC: Directive on the minimum health and safety requirements regarding the exposure of workers to risks arising from physical agents (artificial optical radiation).		<b>N/A</b>
	Standards taking into account mentioned Recommendation and Directive which demonstrate compliance with the applicable EU Directive are indicated in the OJEC.		<b>N/A</b>
Annex H	Replace the last paragraph of this annex by: At any point 10 cm from the surface of the OPERATOR ACCESS AREA, the dose rate shall not exceed 1 µSv/h (0,1 mR/h) (see NOTE). Account is taken of the background level. Replace the notes as follows: NOTE These values appear in Directive 96/29/Euratom. Delete NOTE 2.		<b>N/A</b>
Bibliography	Additional EN standards.		—

<b>ZA</b>	<b>NORMATIVE REFERENCES TO INTERNATIONAL PUBLICATIONS WITH THEIR CORRESPONDING EUROPEAN PUBLICATIONS</b>	—
-----------	--	---

<b>ZB ANNEX (normative) SPECIAL NATIONAL CONDITIONS (EN)</b>			
1.2.4.1	In <b>Denmark</b> , certain types of Class I appliances (see 3.2.1.1) may be provided with a plug not establishing earthing conditions when inserted into Danish socket-outlets.		<b>N/A</b>
1.2.13.14 (A11:2009)	In <b>Norway</b> and <b>Sweden</b> , for requirements see 1.7.2.1 and 7.3 of this annex.		<b>N/A</b>
1.5.7.1 (A11:2009)	In <b>Finland, Norway</b> and <b>Sweden</b> , resistors bridging BASIC INSULATION in CLASS I PLUGGABLE EQUIPMENT TYPE A must comply with the requirements in 1.5.7.1. In addition when a single resistor is used, the resistor must withstand the resistor test in 1.5.7.2.	No such resistors.	<b>N/A</b>

IEC60950_1F - ATTACHMENT			
Clause	Requirement + Test	Result - Remark	Verdict
1.5.8	In <b>Norway</b> , due to the IT power system used (see annex V, Figure V.7), capacitors are required to be rated for the applicable line-to-line voltage (230 V).		<b>N/A</b>
1.5.9.4	In <b>Finland, Norway</b> and <b>Sweden</b> , the third dashed sentence is applicable only to equipment as defined in 6.1.2.2 of this annex.		<b>N/A</b>
1.7.2.1	In <b>Finland, Norway</b> and <b>Sweden</b> , CLASS I PLUGGABLE EQUIPMENT TYPE A intended for connection to other equipment or a network shall, if safety relies on connection to protective earth or if surge suppressors are connected between the network terminals and accessible parts, have a marking stating that the equipment must be connected to an earthed mains socket-outlet. The marking text in the applicable countries shall be as follows: In <b>Finland</b> : "Laitte on liitettävä suojakoskettimilla varustettuun pistorasiaan" In <b>Norway</b> : "Apparatet må tilkoples jordet stikkontakt" In <b>Sweden</b> : "Apparaten skall anslutas till jordat uttag"	No such equipment.	<b>N/A</b>
1.7.2.1 (A11:2009)	In <b>Norway</b> and <b>Sweden</b> , the screen of the cable distribution system is normally not earthed at the entrance of the building and there is normally no equipotential bonding system within the building. Therefore the protective earthing of the building installation need to be isolated from the screen of a cable distribution system. It is however accepted to provide the insulation external to the equipment by an adapter or an interconnection cable with galvanic isolator, which may be provided by e.g. a retailer. The user manual shall then have the following or similar information in Norwegian and Swedish language respectively, depending on in what country the equipment is intended to be used in: "Equipment connected to the protective earthing of the building installation through the mains connection or through other equipment with a connection to protective earthing – and to a cable distribution system using coaxial cable, may in some circumstances create a fire hazard. Connection to a cable distribution system has therefore to be provided through a device providing electrical isolation below a certain frequency range (galvanic isolator, see EN 60728-11)."		

IEC60950_1F - ATTACHMENT			
Clause	Requirement + Test	Result - Remark	Verdict
	<p>NOTE In Norway, due to regulation for installations of cable distribution systems, and in Sweden, a galvanic isolator shall provide electrical insulation below 5 MHz. The insulation shall withstand a dielectric strength of 1,5 kV r.m.s., 50 Hz or 60 Hz, for 1 min.</p> <p>Translation to Norwegian (the Swedish text will also be accepted in Norway):            "Utstyr som er koplet til beskyttelsesjord via nettplugg og/eller via annet jordtilkoplet utstyr – og er tilkoplet et kabel-TV nett, kan forårsake brannfare. For å unngå dette skal det ved tilkopling av utstyret til kabel-TV nettet installeres en galvanisk isolator mellom utstyret og kabel-TV nettet."            Translation to Swedish:            "Utrustning som är kopplad till skyddsjord via jordat vägguttag och/eller via annan utrustning och samtidigt är kopplad till kabel-TV nät kan i vissa fall medföra risk för brand. För att undvika detta skall vid anslutning av utrustningen till kabel-TV nät galvanisk isolator finnas mellan utrustningen och kabel-TV nätet."</p>		
1.7.2.1 (A2:2013)	<p>In <b>Denmark</b>, CLASS I PLUGGABLE EQUIPMENT TYPE A intended for connection to other equipment or a network shall, if safety relies on connection to protective earth or if surge suppressors are connected between the network terminals and accessible parts, have a marking stating that the equipment must be connected to an earthed mains socket-outlet.</p> <p>The marking text in <b>Denmark</b> shall be as follows:            In <b>Denmark</b>: "Apparatets stikprop skal tilsluttes en stikkontakt med jord, som giver forbindelse til stikproppens jord."</p>	No such equipment.	N/A
1.7.5  1.7.5 (A11:2009)	<p>In <b>Denmark</b>, socket-outlets for providing power to other equipment shall be in accordance with the Heavy Current Regulations, Section 107-2-D1, Standard Sheet DK 1-3a, DK 1-5a or DK 1-7a, when used on Class I equipment. For STATIONARY EQUIPMENT the socket-outlet shall be in accordance with Standard Sheet DK 1-1b or DK 1-5a.</p> <p>For <b>CLASS II EQUIPMENT</b> the socket outlet shall be in accordance with Standard Sheet DKA 1-4a.</p>	No socket-outlet provided.	N/A

IEC60950_1F - ATTACHMENT			
Clause	Requirement + Test	Result - Remark	Verdict
1.7.5 (A2:2013)	<p>In <b>Denmark</b>, socket-outlets for providing power to other equipment shall be in accordance with the DS 60884-2-D1:2011.</p> <p>For class I equipment the following Standard Sheets are applicable: DK 1-3a, DK 1-1c, DK 1-1d, DK 1-5a or DK 1-7a, with the exception for STATIONARY EQUIPMENT where the socket-outlets shall be in accordance with Standard Sheet DK 1-1b, DK 1-1c, DK 1-1d or DK 1-5a.</p> <p>Socket outlets intended for providing power to Class II apparatus with a rated current of 2,5 A shall be in accordance with DS 60884-2-D1 standard sheet DKA 1-4a. Other current rating socket outlets shall be in compliance with by DS 60884-2-D1 Standard Sheet DKA 1-3a or DKA 1-3b.</p> <p>Justification the Heavy Current Regulations, 6c</p>	No socket-outlet provided.	<b>N/A</b>
2.2.4	In <b>Norway</b> , for requirements see 1.7.2.1, 6.1.2.1 and 6.1.2.2 of this annex.	No TNV.	<b>N/A</b>
2.3.2	In <b>Finland, Norway and Sweden</b> there are additional requirements for the insulation. See 6.1.2.1 and 6.1.2.2 of this annex.	No TNV.	<b>N/A</b>
2.3.4	In <b>Norway</b> , for requirements see 1.7.2.1, 6.1.2.1 and 6.1.2.2 of this annex.	No TNV.	<b>N/A</b>
2.6.3.3	In the <b>United Kingdom</b> , the current rating of the circuit shall be taken as 13 A, not 16 A.		<b>N/A</b>
2.7.1	In the <b>United Kingdom</b> , to protect against excessive currents and short-circuits in the PRIMARY CIRCUIT of DIRECT PLUG-IN EQUIPMENT, tests according to 5.3 shall be conducted, using an external protective device rated 30 A or 32 A. If these tests fail, suitable protective devices shall be included as integral parts of the DIRECT PLUG-IN EQUIPMENT, so that the requirements of 5.3 are met.	Not direct plug-in equipment	<b>N/A</b>
2.10.5.13	In <b>Finland, Norway and Sweden</b> , there are additional requirements for the insulation, see 6.1.2.1 and 6.1.2.2 of this annex.		<b>N/A</b>
3.2.1.1	<p>In <b>Switzerland</b>, supply cords of equipment having a RATED CURRENT not exceeding 10 A shall be provided with a plug complying with SEV 1011 or IEC 60884-1 and one of the following dimension sheets:</p> <p>SEV 6532-2.1991 Plug Type 15 3P+N+PE 250/400 V, 10 A</p>		<b>N/A</b>



IEC60950_1F - ATTACHMENT			
Clause	Requirement + Test	Result - Remark	Verdict
	<p>SEV 6533-2.1991 Plug Type 11 L+N 250 V, 10 A</p> <p>SEV 6534-2.1991 Plug Type 12 L+N+PE 250 V, 10 A</p> <p>In general, EN 60309 applies for plugs for currents exceeding 10 A. However, a 16 A plug and socket-outlet system is being introduced in Switzerland, the plugs of which are according to the following dimension sheets, published in February 1998: SEV 5932-2.1998: Plug Type 25 , 3L+N+PE 230/400 V, 16 A</p> <p>SEV 5933-2.1998: Plug Type 21, L+N, 250 V, 16A</p> <p>SEV 5934-2.1998: Plug Type 23, L+N+PE 250 V, 16 A</p>		
3.2.1.1	<p>In <b>Denmark</b>, supply cords of single-phase equipment having a rated current not exceeding 13 A shall be provided with a plug according to the Heavy Current Regulations, Section 107-2-D1. CLASS I EQUIPMENT provided with socket-outlets with earth contacts or which are intended to be used in locations where protection against indirect contact is required according to the wiring rules shall be provided with a plug in accordance with standard sheet DK 2-1a or DK 2-5a. If poly-phase equipment and single-phase equipment having a RATED CURRENT exceeding 13 A is provided with a supply cord with a plug, this plug shall be in accordance with the Heavy Current Regulations, Section 107-2-D1 or EN 60309-2.</p>		N/A
3.2.1.1 (A2:2013)	<p>In <b>Denmark</b>, supply cords of single-phase equipment having a rated current not exceeding 13 A shall be provided with a plug according to DS 60884-2-D1. CLASS I EQUIPMENT provided with socket-outlets with earth contacts or which are intended to be used in locations where protection against indirect contact is required according to the wiring rules shall be provided with a plug in accordance with standard sheet DK 2-1a or DK 2-5a. If a single-phase equipment having a RATED CURRENT exceeding 13 A or if a poly-phase equipment is provided with a supply cord with a plug, this plug shall be in accordance with the standard sheets DK 6-1a in DS 60884-2-D1 or EN 60309-2. Justification the Heavy Current Regulations, 6c</p>		N/A

IEC60950_1F - ATTACHMENT			
Clause	Requirement + Test	Result - Remark	Verdict
3.2.1.1	<p>In <b>Spain</b>, supply cords of single-phase equipment having a rated current not exceeding 10 A shall be provided with a plug according to UNE 20315:1994.</p> <p>Supply cords of single-phase equipment having a rated current not exceeding 2,5 A shall be provided with a plug according to UNE-EN 50075:1993.</p> <p>CLASS I EQUIPMENT provided with socket-outlets with earth contacts or which are intended to be used in locations where protection against indirect contact is required according to the wiring rules, shall be provided with a plug in accordance with standard UNE 20315:1994.</p> <p>If poly-phase equipment is provided with a supply cord with a plug, this plug shall be in accordance with UNE-EN 60309-2.</p>		N/A
3.2.1.1	<p>In the <b>United Kingdom</b>, apparatus which is fitted with a flexible cable or cord and is designed to be connected to a mains socket conforming to BS 1363 by means of that flexible cable or cord and plug, shall be fitted with a 'standard plug' in accordance with Statutory Instrument 1768:1994 - The Plugs and Sockets etc. (Safety) Regulations 1994, unless exempted by those regulations.</p> <p>NOTE 'Standard plug' is defined in SI 1768:1994 and essentially means an approved plug conforming to BS 1363 or an approved conversion plug.</p>		N/A
3.2.1.1	<p>In <b>Ireland</b>, apparatus which is fitted with a flexible cable or cord and is designed to be connected to a mains socket conforming to I.S. 411 by means of that flexible cable or cord and plug, shall be fitted with a 13 A plug in accordance with Statutory Instrument 525:1997 - National Standards Authority of Ireland (section 28) (13 A Plugs and Conversion Adaptors for Domestic Use) Regulations 1997.</p>		N/A
3.2.4	<p>In <b>Switzerland</b>, for requirements see 3.2.1.1 of this annex.</p>		N/A
3.2.5.1	<p>In the <b>United Kingdom</b>, a power supply cord with conductor of 1,25 mm<sup>2</sup> is allowed for equipment with a rated current over 10 A and up to and including 13 A.</p>		N/A
3.3.4	<p>In the <b>United Kingdom</b>, the range of conductor sizes of flexible cords to be accepted by terminals for equipment with a RATED CURRENT of over 10 A up to and including 13 A is:</p> <ul style="list-style-type: none"> <li>• 1,25 mm<sup>2</sup> to 1,5 mm<sup>2</sup> nominal cross-sectional area.</li> </ul>	No supply cords provided.	N/A

IEC60950_1F - ATTACHMENT			
Clause	Requirement + Test	Result - Remark	Verdict
4.3.6	In the <b>United Kingdom</b> , the torque test is performed using a socket outlet complying with BS 1363 part 1:1995, including Amendment 1:1997 and Amendment 2:2003 and the plug part of DIRECT PLUG-IN EQUIPMENT shall be assessed to BS 1363: Part 1, 12.1, 12.2, 12.3, 12.9, 12.11, 12.12, 12.13, 12.16 and 12.17, except that the test of 12.17 is performed at not less than 125 °C. Where the metal earth pin is replaced by an Insulated Shutter Opening Device (ISOD), the requirements of clauses 22.2 and 23 also apply.		<b>N/A</b>
4.3.6	In <b>Ireland</b> , DIRECT PLUG-IN EQUIPMENT is known as plug similar devices. Such devices shall comply with Statutory Instrument 526:1997 - National Standards Authority of Ireland (Section 28) (Electrical plugs, plug similar devices and sockets for domestic use) Regulations, 1997.		<b>N/A</b>
5.1.7.1	In <b>Finland, Norway and Sweden</b> TOUCH CURRENT measurement results exceeding 3,5 mA r.m.s. are permitted only for the following equipment: <ul style="list-style-type: none"> <li>• STATIONARY PLUGGABLE EQUIPMENT TYPE A that <ul style="list-style-type: none"> <li>is intended to be used in a RESTRICTED ACCESS LOCATION where equipotential bonding has been applied, for example, in a telecommunication centre; and</li> <li>has provision for a permanently connected PROTECTIVE EARTHING CONDUCTOR; and</li> <li>is provided with instructions for the installation of that conductor by a SERVICE PERSON;</li> </ul> </li> <li>• STATIONARY PLUGGABLE EQUIPMENT TYPE B;</li> <li>• STATIONARY PERMANENTLY CONNECTED EQUIPMENT.</li> </ul>		<b>N/A</b>
6.1.2.1 (A1:2010)	In <b>Finland, Norway and Sweden</b> , add the following text between the first and second paragraph of the compliance clause: If this insulation is solid, including insulation forming part of a component, it shall at least consist of either <ul style="list-style-type: none"> <li>- two layers of thin sheet material, each of which shall pass the electric strength test below, or</li> <li>- one layer having a distance through insulation of at least 0,4 mm, which shall pass the electric strength test below.</li> </ul> Alternatively for components, there is no distance through insulation requirements for the insulation consisting of an insulating compound completely filling the casing, so that CLEARANCES and CREEPAGE DISTANCES do not exist, if the component passes the electric strength test in		<b>N/A</b>

IEC60950_1F - ATTACHMENT			
Clause	Requirement + Test	Result - Remark	Verdict
	<p>accordance with the compliance clause below and in addition</p> <ul style="list-style-type: none"> <li>- passes the tests and inspection criteria of 2.10.11 with an electric strength test of 1,5 kV multiplied by 1,6 (the electric strength test of 2.10.10 shall be performed using 1,5 kV), and</li> <li>- is subject to ROUTINE TESTING for electric strength during manufacturing, using a test voltage of 1,5 kV.</li> </ul>		
	<p>It is permitted to bridge this insulation with an optocoupler complying with 2.10.5.4 b).</p> <p>It is permitted to bridge this insulation with a capacitor complying with EN 60384-14:2005, subclass Y2.</p> <p>A capacitor classified Y3 according to EN 60384-14:2005, may bridge this insulation under the following conditions:</p> <ul style="list-style-type: none"> <li>- the insulation requirements are satisfied by having a capacitor classified Y3 as defined by EN 60384-14, which in addition to the Y3 testing, is tested with an impulse test of 2,5 kV defined in EN 60950-1:2006, 6.2.2.1;</li> <li>- the additional testing shall be performed on all the test specimens as described in EN 60384-14:</li> <li>- the impulse test of 2,5 kV is to be performed before the endurance test in EN 60384-14, in the sequence of tests as described in EN 60384-14.</li> </ul>		N/A
6.1.2.2	<p>In <b>Finland, Norway and Sweden</b>, the exclusions are applicable for PERMANENTLY CONNECTED EQUIPMENT, PLUGGABLE EQUIPMENT TYPE B and equipment intended to be used in a RESTRICTED ACCESS LOCATION where equipotential bonding has been applied, e.g. in a telecommunication centre, and which has provision for a permanently connected PROTECTIVE EARTHING CONDUCTOR and is provided with instructions for the installation of that conductor by a SERVICE PERSON.</p>		N/A
7.2	<p>In <b>Finland, Norway and Sweden</b>, for requirements see 6.1.2.1 and 6.1.2.2 of this annex.</p> <p>The term TELECOMMUNICATION NETWORK in 6.1.2 being replaced by the term CABLE DISTRIBUTION SYSTEM.</p>		N/A
7.3 (A11:2009)	<p>In <b>Norway and Sweden</b>, for requirements see 1.2.13.14 and 1.7.2.1 of this annex.</p>		N/A

IEC60950_1F - ATTACHMENT			
Clause	Requirement + Test	Result - Remark	Verdict

**Annex ZD  
(informative)**

**IEC and CENELEC code designations for flexible cords**

Type of flexible cord	Code designations	
	IEC	CENELEC
<b>PVC insulated cords</b>		
Flat twin tinsel cord	60227 IEC 41	H03VH-Y
Light polyvinyl chloride sheathed flexible cord	60227 IEC 52	H03VV-F H03VVH2-F
Ordinary polyvinyl chloride sheathed flexible cord	60277 IEC 53	H05VV-F H05VVH2-F
<b>Rubber insulated cords</b>		
Braided cord	60245 IEC 51	H03RT-F
Ordinary tough rubber sheathed flexible cord	60245 IEC 53	H05RR-F
Ordinary polychloroprene sheathed flexible cord	60245 IEC 57	H05RN-F
Heavy polychloroprene sheathed flexible cord	60245 IEC 66	H07RN-F
<b>Cords having high flexibility</b>		
Rubber insulated and sheathed cord	60245 IEC 86	H03RR-H
Rubber insulated, crosslinked PVC sheathed cord	60245 IEC 87	H03RV4-H
Crosslinked PVC insulated and sheathed cord	60245 IEC 88	H03V4V4-H

IEC60950_1F - ATTACHMENT			
Clause	Requirement + Test	Result - Remark	Verdict

<b>CANADA NATIONAL DIFFERENCES</b> Information technology equipment – Safety – Part 1: General requirements
<b>Differences according to</b> .....: CAN/CSA C22.2 No. 60950-1-07 + A1:2011 + A2: 2014

	Speial national conditions		
1.1.1	All equipment is to be designed to allow installation in accordance with the National Electrical Code (NEC), ANSI/NFPA 70, the Canadian Electrical Code (CEC), Part I, CAN/CSA C22.1, and when applicable, the National Electrical Safety Code, IEEE C2.		N/A
	Also, unless marked or otherwise identified, installation is allowed per the Standard for the Protection of Electronic Computer/Data-Processing Equipment, ANSI/NFPA 75.		N/A
1.1.2	Baby monitors are required to comply with ASTM F2951, Consumer Safety Specification for Baby Monitors		N/A
1.4.14	For Pluggable Equipment Type A, the protection in the installation is assumed to be 20A.		N/A
1.5.5	For lengths exceeding 3.05 m, external interconnecting flexible cord and cable assemblies are required to be a suitable cable type (e.g., DP, CL2) specified in the CEC/NEC.	No external cable provided.	N/A
	For lengths 3.05 m or less, external interconnecting flexible cord and cable assemblies that are not types specified in the CEC are required to have special construction features and identification markings.		N/A
1.7.1	Equipment for use on a.c. mains supply systems with a neutral and more than one phase conductor (e.g. 120/240 V, 3-wire) require a special marking format for electrical ratings.		N/A
	A voltage rating that exceeds an attachment plug cap rating is only permitted if it does not exceed the extreme operating conditions in Table 2 of CAN/CSA C22.2 No. 235, and		N/A
	- if it is part of a range that extends into the Table 2 "Normal Operating Conditions."		N/A
	A voltage rating is not be lower than the specified "Normal Operating Conditions," unless it is part of a range that extends into the "Normal Operating Conditions."		N/A

IEC60950_1F - ATTACHMENT			
Clause	Requirement + Test	Result - Remark	Verdict
1.7.7	Wiring terminals intended to supply Class 2 outputs in accordance with CEC Part 1 or NEC are marked with the voltage rating and "Class 2" or equivalent.	No wiring terminals.	<b>N/A</b>
	- Marking is located adjacent to the terminals		<b>N/A</b>
	- Marking is visible during wiring		<b>N/A</b>
2.5	Where a fuse is used to provide Class 2, Limited Power Source, or TNV current limiting, it shall not be operator-accessible unless it is not interchangeable.		<b>N/A</b>
2.6	Equipment with isolated ground (earthing) receptacles is required to comply with NEC 250.146(D) and CEC 10-112 and 10-906(8).		<b>N/A</b>
2.7.1	Suitable NEC/CEC branch circuit protection rated at the maximum circuit rating is provided for all standard supply outlets and receptacles (such as supplied in power distribution units) if the supply branch circuit protection is not suitable.	No such components provided.	<b>N/A</b>
	Power distribution transformers distributing power at 100 volts or more, and rated 10 kVA or more, provided with special transformer overcurrent protection.		<b>N/A</b>
3.2	Wiring methods (terminals, leads, etc.) used for the connection of the equipment to the mains is in accordance with the NEC/CEC.		<b>N/A</b>
3.2.1	Power supply cords are required to have attachment plugs rated not less than 125 percent of the rated current of the equipment.	No power supply cord provided.	<b>N/A</b>
3.2.1.2	Equipment connected to a centralized d.c. power system, and having one pole of the DC mains input terminal connected to the main protective earthing terminal in the equipment comply with special earthing, wiring, marking and installation instruction requirements.	No connection to a centralized d.c. power system.	<b>N/A</b>
3.2.3	Permanent connection of equipment to the mains supply by a power supply cord is not permitted, except for certain equipment, such as ATMs.		<b>N/A</b>
3.2.5	Power supply cords are no longer than 4.5 m in length.	No power supply cord provided.	<b>N/A</b>
	Minimum cord length is 1.5 m, with certain constructions such as external power supplies allowed to consider both input and output cord lengths into the requirement.		<b>N/A</b>
	Flexible power supply cords are compatible with Article 400 of the NEC, and Tables 11 and 12 of the CEC.		<b>N/A</b>

IEC60950_1F - ATTACHMENT			
Clause	Requirement + Test	Result - Remark	Verdict
3.2.9	Permanently connected equipment have a suitable wiring compartment and wire bending space.		N/A
3.3	Wiring terminals and associated spacings for field wiring connections comply with CSA C22.2 No. 0.		N/A
3.3.3	Wire binding screws are not permitted to attach conductors larger than 10 AWG (5.3 mm <sup>2</sup> ).		N/A
3.3.4	Terminals for permanent wiring, including protective earthing terminals, are suitable for Canadian/US wire gauge sizes, are		N/A
	- rated 125 percent of the equipment rating, and		N/A
	- are specially marked when specified (1.7.7).		N/A
3.3.5	First column of Table 3E revised to require "Smaller of the RATED CURRENT of the equipment or the PROTECTIVE CURRENT RATING of the circuit under consideration."		N/A
3.4.2	Motor control devices are provided for cord-connected equipment with a motor if the equipment is rated more than 12 A,	Equipment is not such a device.	N/A
	- or if the motor has a nominal voltage rating greater than 120 V		N/A
	- or is rated more than 1/3 hp (locked rotor current over 43 A)		N/A
3.4.8	Vertically-mounted disconnect switches and circuit breakers have the "on" position indicated by the handle in the up position.	No such devices incorporated.	N/A
3.4.11	For computer room applications, equipment with battery systems capable of supplying 750 VA for five minutes have a battery disconnect means that may be connected to the computer room remote power-off circuit.	Not such an application.	N/A
4.3.12	The maximum quantity of flammable liquid stored in equipment complies with NFPA 30.	No liquids.	N/A
4.3.13.5.1	Equipment with lasers meet the Canadian Radiation Emitting Devices Act, REDR C1370 and/or Code of Federal Regulations 21 CFR 1040, as applicable.	No lasers.	N/A
4.7	For computer room applications, automated information storage systems with combustible media greater than 0.76 m <sup>3</sup> (27 cu ft) have a provision for connection of either automatic sprinklers or a gaseous agent extinguishing system with an extended discharge.	Not such an application.	N/A
4.7.3.1	For computer room applications, enclosures with combustible material measuring greater than 0.9 m <sup>2</sup> (10 sq ft) or a single dimension greater than 1.8 m (6 ft) have a flame spread rating of 50 or less.	Not such an application.	N/A



IEC60950_1F - ATTACHMENT			
Clause	Requirement + Test	Result - Remark	Verdict
	For other applications, enclosures with the same dimensions require a flame spread rating of 200 or less.		<b>N/A</b>
Annex H	Equipment that produces ionizing radiation comply with the Canadian Radiation Emitting Devices Act, REDR C1370 and/or Code of Federal Regulations, 21 CFR 1020, as applicable.	Equipment is not such a device.	<b>N/A</b>
	<b>Other National Differences</b>		
1.5.1	Some components and materials associated with the risk of fire, electric shock, or personal injury have component or material ratings in accordance with the applicable national (Canadian and/or U.S.) component or material standard requirements. These components include: attachment plugs, battery packs (rechargeable type, used with transportable equipment), cathode ray tubes, circuit breakers, communication circuit accessories, connectors (used for current interruption of non-LPS circuits), cord sets and power supply cords, direct plug-in equipment, enclosures (outdoor), flexible cords and cables, fuses (branch circuit), fuseholders, ground-fault current interrupters, industrial control equipment, insulating tape, interconnecting cables, lampholders, limit controls, printed wiring, protectors for communications circuits, receptacles, solid state controls, supplementary protectors, switches (including interlock switches), thermal cutoffs, thermostats, (multi-layer) transformer winding wire, transient voltage surge suppressors, tubing, wire connectors, and wire and cables.	Complied. See table 1.5.1	<b>P</b>
1.6.1.2	A circuit for connection to the DC Mains Supply is classified as either a SELV Circuit, TNV-2 Circuit or Hazardous Voltage Circuit depending on the maximum operating voltage of the supply.	No connection to the DC Mains Supply.	<b>N/A</b>
	This maximum operating voltage includes consideration of the battery charging "float voltage" associated with the intended supply system, regardless of the marked power rating of the equipment.		<b>N/A</b>
2.3.1	For TNV-2 and TNV-3 circuits with other than ringing signals and with voltages exceeding 42.4 V <sub>peak</sub> or 60 V <sub>d.c.</sub> , the maximum acceptable current through a 2000 ohm resistor (or greater) connected across the voltage source with other loads disconnected is 7.1 mA peak or 30 mA d.c. under normal operating conditions.	No TNV circuits.	<b>N/A</b>
2.3.2.1	In the event of a single fault between TNV and SELV circuits, the limits of 2.2.3 apply to SELV Circuits and accessible conductive parts.	No TNV circuits.	<b>N/A</b>

IEC60950_1F - ATTACHMENT			
Clause	Requirement + Test	Result - Remark	Verdict
2.6.2	Equipment with functional earthing is required to be marked with the functional earthing symbol (IEC 60417-6092)		<b>P</b>
2.6.3.4	Protective bonding conductors of non-standard protective bonding constructions (e.g., printed circuit traces) may be subjected to the additional limited short circuit test conditions specified.		<b>N/A</b>
4.2.8.1	Enclosures around CRTs with a face diameter of 160 mm or more reduce the risk of injury due to the implosion of the CRT.	No CRTs.	<b>N/A</b>
4.3.2	Equipment with handles complies with special loading tests.	No handles.	<b>N/A</b>
4.3.8	Battery packs for both portable and stationary applications are required to comply with special component requirements.		<b>N/A</b>
5.1.8.3	Equipment intended to receive telecommunication ringing signals comply with a special touch current measurement tests.	No TNV	<b>N/A</b>
5.3.7	Internal (e.g., card cage) SELV circuit connectors and printed wiring board connectors that are accessible to the operator and that deliver power are overloaded.		<b>N/A</b>
	During abnormal operating testing, if a circuit is interrupted by the opening of a component, the test shall be repeated twice (three tests total) using new components as necessary		<b>N/A</b>
6.4	Equipment intended for connection to telecommunication network outside plant cable is protected against overvoltage from power line crosses in accordance with 6.4 and Annex NAC.	No TNV.	<b>N/A</b>
Annex EE	Articulated accessibility probe (Fig EE.3) is used for assessing accessibility to document/media shredders instead of the Figure 2A test finger.	Equipment is not such a device.	<b>N/A</b>
M.2	Continuous ringing signals up to 16 mA only are permitted if the equipment is subjected to special installation and performance restrictions.	No TNV.	<b>N/A</b>
Annex NAD	Equipment connected to a telecommunication and cable distribution networks and supplied with an earphone intended to be held against, or in the ear comply with special acoustic pressure requirements.	No TNV.	<b>N/A</b>

IEC60950_1F - ATTACHMENT			
Clause	Requirement + Test	Result - Remark	Verdict

<b>ATTACHMENT TO TEST REPORT IEC 60950-1</b> <b>FINLAND NATIONAL DIFFERENCES</b> Information technology equipment – Safety – Part 1: General requirements			
<b>Differences according to</b> .....: EN 60950-1:2006/A11:2009/A1:2010			
<b>Attachment Form No.</b> ....: FI_ND_IEC60950_1C			
<b>Attachment Originator</b> .....: SGS Fimko Ltd			
<b>Master Attachment</b> .....: Date (2010-04)			
Copyright © 2010 IEC System for Conformity Testing and Certification of Electrical Equipment (IECEE), Geneva, Switzerland. All rights reserved.			

	National Differences		
<b>General</b>	See also Group Differences (EN 60950-1:2006/A11/A1)		
1.5.7.1	In <b>Finland</b> resistors bridging BASIC INSULATION in CLASS I PLUGGABLE EQUIPMENT TYPE A must comply with the requirements in 1.5.7.1. In addition when a single resistor is used, the resistor must withstand the resistor test in 1.5.7.2.		<b>N/A</b>
1.5.9.4	In <b>Finland</b> , the third dashed sentence is applicable only to equipment as defined in 6.1.2.2 of this annex.	No such construction.	<b>N/A</b>
1.7.2.1	In <b>Finland</b> , CLASS I PLUGGABLE EQUIPMENT TYPE A intended for connection to other equipment or a network shall, if safety relies on connection to protective earth or if surge suppressors are connected between the network terminals and accessible parts, have a marking stating that the equipment must be connected to an earthed mains socket-outlet. The marking text in in Finland shall be as follows: "Laitte on liitettävä suojakoskettimilla varustettuun pistorasiaan"		<b>N/A</b>
2.3.2	In <b>Finland</b> , there are additional requirements for the insulation. See 6.1.2.1 and 6.1.2.2 of this annex.	No TNV.	<b>N/A</b>
2.10.5.13	In <b>Finland</b> , there are additional requirements for the insulation, see 6.1.2.1 and 6.1.2.2 of this annex.	No TNV.	<b>N/A</b>

IEC60950_1F - ATTACHMENT			
Clause	Requirement + Test	Result - Remark	Verdict
5.1.7.1	<p>In <b>Finland</b>, TOUCH CURRENT measurement results exceeding 3,5 mA r.m.s. are permitted only for the following equipment:</p> <ul style="list-style-type: none"> <li>• STATIONARY PLUGGABLE EQUIPMENT TYPE A that <ul style="list-style-type: none"> <li>- is intended to be used in a RESTRICTED ACCESS LOCATION where equipotential bonding has been applied, for example, in a telecommunication centre; and</li> <li>- has provision for a permanently connected PROTECTIVE EARTHING CONDUCTOR; and</li> <li>- is provided with instructions for the installation of that conductor by a SERVICE PERSON;</li> </ul> </li> <li>• STATIONARY PLUGGABLE EQUIPMENT TYPE B;</li> <li>• STATIONARY PERMANENTLY CONNECTED EQUIPMENT.</li> </ul>		<b>N/A</b>
6.1.2.1 (A1:2010)	<p>In <b>Finland</b>, add the following text between the first and second paragraph of the compliance clause:</p> <p>If this insulation is solid, including insulation forming part of a component, it shall at least consist of either</p> <ul style="list-style-type: none"> <li>- two layers of thin sheet material, each of which shall pass the electric strength test below, or</li> <li>- one layer having a distance through insulation of at least 0,4 mm, which shall pass the electric strength test below.</li> </ul> <p>Alternatively for components, there is no distance through insulation requirement for the insulation consisting of an insulating compound completely filling the casing, so that CLEARANCES and CREEPAGE DISTANCES do not exist, if the component passes the electric strength test in accordance with the compliance clause below and in addition</p> <ul style="list-style-type: none"> <li>- passes the tests and inspection criteria of 2.10.11 with an electric strength test of 1,5 kV multiplied by 1,6 (the electric strength test of 2.10.10 shall be performed using 1,5 kV), and</li> <li>- is subject to ROUTINE TESTING for electric strength during manufacturing, using a test voltage of 1,5 kV.</li> </ul>	No TNV.	<b>N/A</b>

IEC60950_1F - ATTACHMENT			
Clause	Requirement + Test	Result - Remark	Verdict
	<p>It is permitted to bridge this insulation with an optocoupler complying with 2.10.5.4 b).</p> <p>It is permitted to bridge this insulation with a capacitor complying with EN 60384-14:2005, subclass Y2.</p> <p>A capacitor classified Y3 according to EN 60384-14:2005, may bridge this insulation under the following conditions:</p> <ul style="list-style-type: none"> <li>- the insulation requirements are satisfied by having a capacitor classified Y3 as defined by EN 60384-14:2005 which in addition to the Y3 testing, is tested with an impulse test of 2,5 kV defined in EN 60950-1:2006, 6.2.2.1;</li> <li>- the additional testing shall be performed on all the test specimens as described in EN 60384-14:2005;</li> <li>- the impulse test of 2,5 kV is to be performed before the endurance test in EN 60384-14:2005, in the sequence of tests as described in EN 60384-14:2005.</li> </ul>		
6.1.2.2	<p>In <b>Finland</b>, the exclusions are applicable for PERMANENTLY CONNECTED EQUIPMENT, PLUGGABLE EQUIPMENT TYPE B and equipment intended to be used in a RESTRICTED ACCESS LOCATION where equipotential bonding has been applied, e.g. in a telecommunication centre, and which has provision for a permanently connected PROTECTIVE EARTHING CONDUCTOR and is provided with instructions for the installation of that conductor by a SERVICE PERSON.</p>	No TNV.	<b>N/A</b>
7.2	<p>In <b>Finland</b>, for requirements see 6.1.2.1 and 6.1.2.2 of this annex.</p> <p>The term TELECOMMUNICATION NETWORK in 6.1.2 being replaced by the term CABLE DISTRIBUTION SYSTEM.</p>	Not connected to cable distribution system.	<b>N/A</b>

IEC60950_1F - ATTACHMENT			
Clause	Requirement + Test	Result - Remark	Verdict

<p><b>ATTACHMENT TO TEST REPORT IEC 60950-1</b>  <b>GERMANY NATIONAL DIFFERENCES</b>  Information technology equipment – Safety –  Part 1: General requirements</p>			
Differences according to.....: VDE 0805-1:2011-01			

Annex ZC, 1.7.2.1	According to GPSG, section 2, clause 4: If certain rules on the use, supplementation or maintenance of an item of technical work equipment or ready-to-use commodity must be observed in order to guarantee safety and health, instructions for use in German must be supplied when it is brought into circulation.		<b>N/A</b>
----------------------	--	--	------------

IEC60950_1F - ATTACHMENT			
Clause	Requirement + Test	Result - Remark	Verdict
<b>ATTACHMENT TO TEST REPORT IEC 60950-1</b> <b>ISRAEL NATIONAL DIFFERENCES</b> Information technology equipment – Safety – Part 1: General requirements			
Differences according to.....: SI 60950 Part 1			

1.1.1	Replace the the text of Note 3 as follows: The requirements of Israel Standard SI 60065 may also be used to meet safety requirements for multimedia equipment. See IEC Guide 112, Guide on the safety of multimedia equipment.		N/A
1.6	The clause is applicable with the following addition:		P
1.6.1	Add following note: In Israel, this clause is applicable subject to the Electricity Law, 1954, its regulations and revisions.	Added	P
1.7	The clause is applicable with the following additions: Subclause 1.7.201 shall be added at the beginning of the clause as follows:	Added	P
1.7.201	Marking in the Hebrew language The marking in the Hebrew language shall be in accordance with the Consumer Protection Order (Marking of goods), 1983. In addition to the marking required by clause 1.7.1, the following details shall be marked in the Hebrew language. The details shall be marked on the apparatus or on its package, or on a label properly attached to the apparatus or on the package, by bonding or sewing, in a manner that the label cannot be easily removed. 1. Name of the apparatus and it commercial designation; 2. Manufacturer's name and address. If the apparatus is imported, the importer's name and address; 3. Manufacturer's registered trademark, if any; 4. Name of the model and serial number, if any; 5. Country of manufacture.		N/A
1.7.2.1	The following shall be added to the clause: All the instructions and warnings related to safety shall also be written in the Hebrew language.	Added	N/A
2	The clause is applicable with the following additions:		N/A

IEC60950_1F - ATTACHMENT			
Clause	Requirement + Test	Result - Remark	Verdict
2.9.4	<p>The following shall be added at the beginning of the clause:</p> <p>In Israel, according to the Electricity Law, 1954, and the Electricity Regulations (Earthing and means of protection against electricity of voltages up to 1,000V) 1991, seven means of protection against electrocution are permitted, as follows:</p> <ol style="list-style-type: none"> <li>1) TN-S - Network system earthing; TN-C-S - Network system earthing;</li> <li>2) TT - Network system earthing;</li> <li>3) IT - Network Insulation Terre;</li> <li>4) Isolated transformer;</li> <li>5) Safety extra low voltage (SELV or ELV);</li> <li>6) Residual current circuit breaker (30 mA = I<math>\Delta</math>);</li> <li>7) Reinforced insulation; Double insulation (class II)</li> </ol>		<b>N/A</b>
2.201	<p>Prevention of electromagnetic interference</p> <p>- Prior to carrying out the tests in accordance with the clauses of this Standard, the compliance of the apparatus with the relevant requirements specified in the appropriate part of the Standard series, SI 961, shall be checked.</p> <p><u>The apparatus shall meet the requirements in the appropriate part of the Standard series, SI 961.</u></p> <p>- If there are components in the apparatus for the prevention of electromagnetic interference, these components shall not reduce the safety level of the apparatus as required by this Standard.</p>		<b>N/A</b>
3	The clause is applicable with the following additions:		
3.2.1.1	<p>Connection to an a.c. mains supply</p> <p>After the note, the following note shall be added:</p> <p>Note:</p> <p>In Israel, the feed plug shall comply with the requirements of Israel Standard SI 32 Part 1.1.</p>	No feed plug provided.	<b>N/A</b>
3.2.1.2	<p>Connection to a d.c. mains supply</p> <p>At the end of the first paragraph, the following note shall be added:</p> <p>Note:</p> <p>At the time of issue of this Standard, there is no Israel Standard for connection accessories to d.c.</p>	No connected to d.c. mains supply	<b>N/A</b>
Annex P	<p>Normative references</p> <p>(List of relevant Israel Standards that have been inserted in place of some of the International Standards)</p>	Inserted	<b>N/A</b>



IEC60950_1F - ATTACHMENT			
Clause	Requirement + Test	Result - Remark	Verdict

<p><b>ATTACHMENT TO TEST REPORT IEC 60950-1</b>  <b>KOREA NATIONAL DIFFERENCES</b>  Information technology equipment – Safety –  Part 1: General requirements</p>
<p><b>Differences according to.....:</b> K 60950-1</p>

1.5.101	Plugs for the connection of the apparatus to the supply mains shall comply with the Korean requirement (KSC 8305)	No power supply cord provided.	<b>N/A</b>
8	EMC The apparatus shall comply with the relevant CISPR standards.		<b>N/A</b>

IEC60950_1F - ATTACHMENT			
Clause	Requirement + Test	Result - Remark	Verdict

<b>ATTACHMENT TO TEST REPORT IEC 60950-1</b> <b>U.S.A. NATIONAL DIFFERENCES</b> Information technology equipment – Safety – Part 1: General requirements			
<b>Differences according to</b> .....: UL 60950-1, Edition 2, Amendment 2			
<b>Attachment Form No.</b> ....: N/A			
<b>Attachment Originator</b> .....: N/A			
<b>Master Attachment</b> .....: N/A			

	Special national conditions		
1.1.1	All equipment is to be designed to allow installation in accordance with the National Electrical Code (NEC), ANSI/NFPA 70, the Canadian Electrical Code (CEC), Part I, CAN/CSA C22.1, and when applicable, the National Electrical Safety Code, IEEE C2.	I	N/A
	Also, unless marked or otherwise identified, installation is allowed per the Standard for the Protection of Electronic Computer/Data-Processing Equipment, ANSI/NFPA 75.		N/A
1.1.2	Baby monitors are required to additionally comply with ASTM F2951, Consumer Safety Specification for Baby Monitors.		N/A
1.4.14	For Pluggable Equipment Type A, the protection in the installation is assumed to be 20 A.	Considered.	N/A
1.5.5	For lengths exceeding 3.05 m, external interconnecting flexible cord and cable assemblies are required to be a suitable cable type (e.g., DP, CL2) specified in the NEC.	No external cable provided.	N/A
	For lengths 3.05 m or less, external interconnecting flexible cord and cable assemblies that are not types specified in the NEC are required to have special construction features and identification markings.		N/A
1.7.1	Equipment for use on a.c. mains supply systems with a neutral and more than one phase conductor (e.g. 120/240 V, 3-wire) require a special marking format for electrical ratings.		N/A
	A voltage rating that exceeds an attachment plug cap rating is only permitted if it does not exceed the extreme operating conditions in Table 2 of CAN/CSA C22.2 No. 235, and		N/A
	- if it is part of a range that extends into the Table 2 "Normal Operating Conditions."		N/A

IEC60950_1F - ATTACHMENT			
Clause	Requirement + Test	Result - Remark	Verdict
	A voltage rating shall not be lower than the specified "Normal Operating Conditions," unless it is part of a range that extends into the "Normal Operating Conditions."		N/A
1.7.7	Wiring terminals intended to supply Class 2 outputs in accordance with the NEC or CEC Part 1 shall be marked with the voltage rating and "Class 2" or equivalent.	No wiring terminals.	N/A
	- Marking shall be located adjacent to the terminals		N/A
	- Marking shall be visible during wiring		N/A
2.5	Where a fuse is used to provide Class 2, Limited Power Source, or TNV current limiting, it shall not be operator-accessible unless it is not interchangeable.		N/A
2.6	Equipment with isolated ground (earthing) receptacles are required to comply with NEC 250.146(D) and CEC 10-112 and 10-906(8).		N/A
2.7.1	Suitable NEC/CEC branch circuit protection rated at the maximum circuit rating is required for all standard supply outlets and receptacles (such as supplied in power distribution units) if the supply branch circuit protection is not suitable.	No such components provided.	N/A
	Power distribution transformers distributing power at 100 volts or more, and rated 10 kVA or more, require special transformer overcurrent protection.		N/A
3.2	Wiring methods (terminals, leads, etc.) used for the connection of the equipment to the mains shall be in accordance with the NEC/CEC.		N/A
3.2.1	Power supply cords are required to have attachment plugs rated not less than 125 percent of the rated current of the equipment.		N/A
3.2.1.2	Equipment connected to a centralized d.c. power system, and having one pole of the DC mains input terminal connected to the main protective earthing terminal in the equipment, is required to comply with special earthing, wiring, marking and installation instruction requirements.	No power supply cord provided.	N/A
3.2.3	Permanent connection of equipment to the mains supply by a power supply cord is not permitted, except for certain equipment, such as ATMs.		N/A
3.2.5	Power supply cords are required to be no longer than 4.5 m in length.		N/A
	Minimum cord length is required to be 1.5 m, with certain constructions such as external power supplies allowed to consider both input and output cord lengths into the requirement.		N/A

IEC60950_1F - ATTACHMENT			
Clause	Requirement + Test	Result - Remark	Verdict
	Flexible power supply cords are required to be compatible with Article 400 of the NEC, and Tables 11 & 12 of the CEC.		<b>N/A</b>
3.2.9	Permanently connected equipment is required to have a suitable wiring compartment and wire bending space.		<b>N/A</b>
3.3	Wiring terminals and associated spacings for field wiring connections shall comply with CSA C22.2 No. 0.	No wiring terminals.	<b>N/A</b>
3.3.3	Wire binding screws are not permitted to attach conductors larger than 10 AWG (5.3 mm <sup>2</sup> ).	No wire binding screws.	<b>N/A</b>
3.3.4	Terminals for permanent wiring, including protective earthing terminals, are required to be suitable for U.S./Canadian wire gauge sizes,		<b>N/A</b>
	- rated 125 per cent of the equipment rating, and		<b>N/A</b>
	- are specially marked when specified (1.7.7).		<b>N/A</b>
3.3.5	First column of Table 3E revised to require "Smaller of the RATED CURRENT of the equipment or the PROTECTIVE CURRENT RATING of the circuit under consideration."		<b>N/A</b>
3.4.2	Motor control devices are required for cord-connected equipment with a motor if the equipment is rated more than 12 A,	Equipment is not such a device.	<b>N/A</b>
	- or if the motor has a nominal voltage rating greater than 120 V		<b>N/A</b>
	- or is rated more than 1/3 hp (locked rotor current over 43 A)		<b>N/A</b>
3.4.8	Vertically-mounted disconnect switches and circuit breakers are required to have the "on" position indicated by the handle in the up position.	No such devices incorporated.	<b>N/A</b>
3.4.11	For computer room applications, equipment with battery systems capable of supplying 750 VA for five minutes are required to have a battery disconnect means that may be connected to the computer room remote power-off circuit.	Not such an application.	<b>N/A</b>
4.3.12	The maximum quantity of flammable liquid stored in equipment is required to comply with NFPA 30.	No liquids.	<b>N/A</b>
4.3.13.5.1	Equipment with lasers is required to meet the U.S. Code of Federal Regulations 21 CFR 1040 (and the Canadian Radiation Emitting Devices Act, REDR C1370).	No lasers.	<b>N/A</b>
4.7	For computer room applications, automated information storage systems with combustible media greater than 0.76 m <sup>3</sup> (27 cu ft) are required to have a provision for connection of either automatic sprinklers or a gaseous agent extinguishing system with an extended discharge.	Not such an application.	<b>N/A</b>

IEC60950_1F - ATTACHMENT			
Clause	Requirement + Test	Result - Remark	Verdict
4.7.3.1	For computer room applications, enclosures with combustible material measuring greater than 0.9 m <sup>2</sup> (10 sq ft) or a single dimension greater than 1.8 m (6 ft) are required to have a flame spread rating of 50 or less.	Not such an application.	<b>N/A</b>
	For other applications, enclosures with the same dimensions require a flame spread rating of 200 or less.		<b>N/A</b>
	Non-metallic enclosures of equipment for use in spaces used for environmental air (plenums) are required to comply with UL 2043.		<b>N/A</b>
Annex H	Equipment that produces ionizing radiation is required to comply with the U.S. Code of Federal Regulations, 21 CFR 1020 (and the Canadian Radiation Emitting Devices Act, REDR C1370).	Equipment is not such a device.	<b>N/A</b>
	<b>Other National Differences</b>		
1.5.1	Some components and materials associated with the risk of fire, electric shock, or personal injury are required to have component or material ratings in accordance with the applicable national (U.S. and Canadian) component or material requirements. These components include: attachment plugs, battery backup systems, battery packs, cathode ray tubes, circuit breakers, communication circuit accessories, connectors (used for current interruption of non-LPS circuits), cord sets and power supply cords, direct plug-in equipment, electrochemical capacitor modules (energy storage modules with ultracapacitors), enclosures (outdoor), flexible cords and cables, fuses (branch circuit), fuseholders, ground-fault current interrupters, industrial control equipment, insulating tape, interconnecting cables, lampholders, limit controls, printed wiring, protectors for communications circuits, receptacles, solid state controls, supplementary protectors, switches (including interlock switches), thermal cutoffs, thermostats, (multi-layer) transformer winding wire, surge protective devices, tubing, vehicle battery adapters, wire connectors, and wire and cables.	Complied. See table 1.5.1	<b>P</b>
1.6.1.2	A circuit for connection to the DC Mains Supply is classified as a SELV Circuit, a TNV-2 Circuit or a Hazardous Voltage Circuit depending on the maximum operating voltage of the supply.	No connection to the DC Mains Supply.	<b>N/A</b>
	This maximum operating voltage shall include consideration of the battery charging "float voltage" associated with the intended supply system, regardless of the marked power rating of the equipment.		<b>N/A</b>

IEC60950_1F - ATTACHMENT			
Clause	Requirement + Test	Result - Remark	Verdict
2.3.1	For TNV-2 and TNV-3 circuits with other than ringing signals and with voltages exceeding 42.4 V <sub>peak</sub> or 60 V <sub>d.c.</sub> , the maximum acceptable current through a 2000 ohm resistor (or greater) connected across the voltage source with other loads disconnected is 7.1 mA peak or 30 mA d.c. under normal operating conditions.	No TNV circuits.	<b>N/A</b>
2.3.2.1	In the event of a single fault between TNV and SELV circuits, the limits of 2.2.3 apply to SELV Circuits and accessible conductive parts.	No TNV circuits.	<b>N/A</b>
2.6.2	Equipment with functional earthing is required to be marked with the functional earthing symbol (IEC 60417-6092).		<b>N/A</b>
2.6.3.4	Protective bonding conductors of non-standard protective bonding constructions (e.g., printed circuit traces) may be subjected to the additional limited short circuit test conditions specified.		<b>N/A</b>
4.2.8.1	Enclosures around CRTs with a face diameter of 160 mm or more are required to reduce the risk of injury due to the implosion of the CRT.	No CRTs.	<b>N/A</b>
4.3.2	Equipment with handles is required to comply with special loading tests.	No handles.	<b>N/A</b>
4.3.8	Battery packs for both portable and stationary applications are required to comply with special component requirements.		<b>N/A</b>
5.1.8.3	Equipment intended to receive telecommunication ringing signals is required to comply with a special touch current measurement tests.	No TNV.	<b>N/A</b>
5.3.7	Internal (e.g., card cage) SELV circuit connectors and printed wiring board connectors that are accessible to the operator and that deliver power are to be overloaded.		<b>N/A</b>
	During abnormal operating testing, if a circuit is interrupted by the opening of a component, the test shall be repeated twice (three tests total) using new components as necessary.		<b>N/A</b>
6.4	Equipment intended for connection to telecommunication network outside plant cable is required to be protected against overvoltage from power line crosses in accordance with 6.4 and Annex NAC.	No TNV.	<b>N/A</b>
Annex EE	UL articulated accessibility probe (Fig EE.3) required for assessing accessibility to document/media shredders instead of the Figure 2A test finger.	No document (paper) shredder.	<b>N/A</b>
Annex M.2	Continuous ringing signals up to 16 mA only are permitted if the equipment is subjected to special installation and performance restrictions.	No TNV.	<b>N/A</b>

IEC60950_1F - ATTACHMENT			
Clause	Requirement + Test	Result - Remark	Verdict
Annex NAD	Equipment connected to a telecommunication and cable distribution networks and supplied with an earphone intended to be held against, or in the ear is required to comply with special acoustic pressure requirements.	No TNV.	<b>N/A</b>

IEC60950_1F - ATTACHMENT			
Clause	Requirement + Test	Result - Remark	Verdict

**ATTACHMENT TO TEST REPORT IEC 60950-1**  
**AUSTRALIA and NEW ZEALAND NATIONAL DIFFERENCES**  
Information technology equipment – Safety –  
Part 1: General requirements

**Differences according to**.....: AS/NZS 60950.1:2011 and Amendment No. 1  
To AS/NZS 60950.1:2011

1.2	Insert the following between 'person, service' and 'range, rated frequency': POTENTIAL IGNITION SOURCE ..... 1.2.12		<b>N/A</b>
1.2.12.201	Insert a new Clause 1.2.12.201 after Clause 1.2.12.15 as follows: <b>1.2.12.201</b> <b>POTENTIAL IGNITION SOURCE</b> Possible fault which can start a fire if the open-circuit voltage measured across an interruption or faulty contact exceeds a value of 50 V (peak) a.c. or d.c. and the product of the peak value of this voltage and the measured r.m.s. current under normal operating conditions exceeds 15 VA. Such a faulty contact or interruption in an electrical connection includes those which may occur in CONDUCTIVE PATTERNS on PRINTED BOARDS. NOTE 201 An electronic protection circuit may be used to prevent such a fault from becoming a POTENTIAL IGNITION SOURCE. NOTE 202 This definition is from AS/NZS 60065:2003.		<b>N/A</b>
1.5.1	1. Add the following to the end of the first paragraph: 'or the relevant Australian/New Zealand Standard.' 2. In NOTE 1, add the following after the word 'standard': 'or an Australian/New Zealand Standard'	Added.	<b>P</b>
1.5.2	Add the following to the end of the first and third dash items: 'or the relevant Australian/New Zealand Standard'	Added.	<b>P</b>



IEC60950_1F - ATTACHMENT																				
Clause	Requirement + Test	Result - Remark	Verdict																	
3.2.5.1	<p>Modify Table 3B as follows:</p> <p>1. Delete the first four rows and replace with the following:</p> <table border="1"> <thead> <tr> <th rowspan="2">RATED CURRENT of equipment  A</th> <th colspan="2">Minimum conductor sizes</th> </tr> <tr> <th>Nominal cross-sectional area mm<sup>2</sup></th> <th>AWG or kcmil [cross-sectional area in mm<sup>2</sup>] see Note 2</th> </tr> </thead> <tbody> <tr> <td>Over 0.2 up to and including 3</td> <td>0,5 <sup>a</sup></td> <td>18 [0,8]</td> </tr> <tr> <td>Over 3 up to and including 7.5</td> <td>0,75</td> <td>16 [1,3]</td> </tr> <tr> <td>Over 7.5 up to and including 10</td> <td>(0,75) <sup>b</sup> 1,00</td> <td>16 [1,3]</td> </tr> <tr> <td>Over 10 up to and including 16</td> <td>(1,0) <sup>c</sup> 1,5</td> <td>14 [2]</td> </tr> </tbody> </table> <p>2. Delete NOTE 1.</p> <p>3. Delete Footnote <sup>a</sup> and replace with the following:  <sup>a</sup> This nominal cross-sectional area is only allowed for Class II appliances if the length of the power supply cord, measured between the point where the cord, or cord guard, enters the appliance, and the entry to the plug does not exceed 2 m (0,5 mm<sup>2</sup> three-core supply flexible cords are not permitted; see AS/NZS 3191).</p>	RATED CURRENT of equipment  A	Minimum conductor sizes		Nominal cross-sectional area mm <sup>2</sup>	AWG or kcmil [cross-sectional area in mm <sup>2</sup> ] see Note 2	Over 0.2 up to and including 3	0,5 <sup>a</sup>	18 [0,8]	Over 3 up to and including 7.5	0,75	16 [1,3]	Over 7.5 up to and including 10	(0,75) <sup>b</sup> 1,00	16 [1,3]	Over 10 up to and including 16	(1,0) <sup>c</sup> 1,5	14 [2]	Replaced.	N/A
RATED CURRENT of equipment  A	Minimum conductor sizes																			
	Nominal cross-sectional area mm <sup>2</sup>	AWG or kcmil [cross-sectional area in mm <sup>2</sup> ] see Note 2																		
Over 0.2 up to and including 3	0,5 <sup>a</sup>	18 [0,8]																		
Over 3 up to and including 7.5	0,75	16 [1,3]																		
Over 7.5 up to and including 10	(0,75) <sup>b</sup> 1,00	16 [1,3]																		
Over 10 up to and including 16	(1,0) <sup>c</sup> 1,5	14 [2]																		
4.1.201	<p>Insert a new Clause 4.1.201 after Clause 4.1 as follows:</p> <p><b>4.1.201 Display devices used for television purposes</b></p> <p>Display devices which may be used for television purposes, with a mass of 7 kg or more, shall comply with the requirements for stability and mechanical hazards, including the additional stability requirements for television receivers, specified in AS/NZS 60065.</p>	No such device.	N/A																	
4.3.6	<p>Delete the third paragraph and replace with the following:</p> <p><i>Equipment with a plug portion, suitable for insertion into a 10 A 3-pin flatpin socket-outlet complying with AS/NZS 3112 shall comply with the requirements in AS/NZS 3112 for equipment with integral pins for insertion into socket-outlets.</i></p>		N/A																	
4.3.13.5.1	<p>Add the following to the end of the first paragraph:          'or AS/NZS 2211.1'</p>	Added.	N/A																	

IEC60950_1F - ATTACHMENT			
Clause	Requirement + Test	Result - Remark	Verdict
4.7	Add the following new paragraph to the end of the clause: 'For alternate tests refer to Clause 4.7.201.'		N/A
4.7.201	Insert a new Clause 4.7.201 after Clause 4.7.3.6 as follows: <b>4.7.201 Resistance to fire – Alternative tests</b>		N/A
4.7.201.1	<p><b>4.7.201.1 General</b></p> <p>Parts of non-metallic material shall be resistant to ignition and spread of fire.</p> <p>This requirement does not apply to decorative trims, knobs and other parts unlikely to be ignited or to propagate flames from inside the apparatus, or the following:</p> <p>(a) Components that are contained in an enclosure having a flammability category of V-0 according to AS/NZS 60695.11.10 and having openings only for the connecting wires filling the openings completely, and for ventilation not exceeding 1mm in width regardless of length.</p> <p>(b) The following parts which would contribute negligible fuel to a fire:</p> <ul style="list-style-type: none"> <li>- small mechanical parts, the mass of which does not exceed 4g, such as mounting parts, gears, cams, belts and bearings;</li> <li>- small electrical components, such as capacitors with a volume not exceeding 1,750 mm<sup>3</sup>, integrated circuits, transistors and optocoupler packages, if these components are mounted on material of flammability category V-1, or better, according to AS/NZS 60695.11.10.</li> </ul> <p>NOTE In considering how to minimize propagation of fire and what 'small parts' are, account should be taken of the cumulative effect of small parts adjacent to each other for the possible effect of propagating the fire from one part to another.</p> <p>Compliance shall be checked by the tests of 4.7.201.2, 4.7.201.3, 4.7.201.4 and 4.7.201.5.</p> <p>For the base material of printed boards, compliance shall be checked by the test of 4.7.201.5.</p> <p>The tests shall be carried out on parts of non-metallic material which have been removed from the apparatus. When the glow-wire test is carried out, the parts shall be placed in the same orientation as they would be in normal use.</p> <p>These tests are not carried out on internal wiring.</p>		N/A

IEC60950_1F - ATTACHMENT									
Clause	Requirement + Test	Result - Remark	Verdict						
4.7.201.2	<p><b>4.7.201.2 Testing of non-metallic materials</b></p> <p>Parts of non-metallic material shall be subject to the glow-wire test of AS/NZS 60695.2.11 which shall be carried out at 550 °C.</p> <p>Parts for which the glow-wire test cannot be carried out, such as those made of soft or foamy material, shall meet the requirements specified in ISO 9772 for category FH-3 material. The glow-wire test shall be not carried out on parts of material classified at least FH-3 according to ISO 9772 provided that the sample tested was not thicker than the relevant part.</p>		N/A						
4.7.201.3	<p><b>4.7.201.3 Testing of insulating materials</b></p> <p>Parts of insulating material supporting POTENTIAL IGNITION SOURCES shall be subject to the glow-wire test of AS/NZS 60695.2.11 which shall be carried out at 750 °C.</p> <p>The test shall be also carried out on other parts of insulating material which are within a distance of 3 mm of the connection.</p> <p>NOTE Contacts in components such as switch contacts are considered to be connections.</p> <p>For parts which withstand the glow-wire test but produce a flame, other parts above the connection within the envelope of a vertical cylinder having a diameter of 20 mm and a height of 50 mm shall be subjected to the needle-flame test. However, parts shielded by a barrier which meets the needle-flame test shall not be tested.</p> <p>The needle-flame test shall be made in accordance with AS/NZS 60695.11.5 with the following modifications:</p> <table border="1"> <tr> <td>Clause of AS/NZS 60695.11.5</td> <td>Change</td> </tr> <tr> <td colspan="2">9 Test procedure</td> </tr> <tr> <td>9.2 Application of needleflame</td> <td>           Replace the first paragraph with:            The specimen shall be arranged so that the flame can be applied to a vertical or horizontal edge as shown in the examples of figure 1. If possible the flame shall be applied at least 10 mm from a corner             Replace the second paragraph with:            The duration of application of the test flame shall be 30 s         </td> </tr> </table>	Clause of AS/NZS 60695.11.5	Change	9 Test procedure		9.2 Application of needleflame	Replace the first paragraph with: The specimen shall be arranged so that the flame can be applied to a vertical or horizontal edge as shown in the examples of figure 1. If possible the flame shall be applied at least 10 mm from a corner  Replace the second paragraph with: The duration of application of the test flame shall be 30 s		N/A
Clause of AS/NZS 60695.11.5	Change								
9 Test procedure									
9.2 Application of needleflame	Replace the first paragraph with: The specimen shall be arranged so that the flame can be applied to a vertical or horizontal edge as shown in the examples of figure 1. If possible the flame shall be applied at least 10 mm from a corner  Replace the second paragraph with: The duration of application of the test flame shall be 30 s								

IEC60950_1F - ATTACHMENT									
Clause	Requirement + Test	Result - Remark	Verdict						
	<table border="1"> <tr> <td></td> <td>±1 s.</td> </tr> <tr> <td>9.3 Number of test specimens</td> <td>Replace with: The test shall be made on one specimen. If the specimen does not withstand the test, the test may be repeated on two further specimens, both of which shall withstand the test.</td> </tr> <tr> <td>11 Evaluation of test results</td> <td>Replace with: The duration of burning (<math>t_b</math>) shall not exceed 30 s. However, for printed circuit boards, it shall not exceed 15 s.</td> </tr> </table> <p>The needle-flame test shall not be carried out on parts of material classified as V-0 or V-1 according to AS/NZS 60695.11.10, provided that the sample tested was not thicker than the relevant part.</p>		±1 s.	9.3 Number of test specimens	Replace with: The test shall be made on one specimen. If the specimen does not withstand the test, the test may be repeated on two further specimens, both of which shall withstand the test.	11 Evaluation of test results	Replace with: The duration of burning ( $t_b$ ) shall not exceed 30 s. However, for printed circuit boards, it shall not exceed 15 s.		
	±1 s.								
9.3 Number of test specimens	Replace with: The test shall be made on one specimen. If the specimen does not withstand the test, the test may be repeated on two further specimens, both of which shall withstand the test.								
11 Evaluation of test results	Replace with: The duration of burning ( $t_b$ ) shall not exceed 30 s. However, for printed circuit boards, it shall not exceed 15 s.								
4.7.201.4	<p><b>4.7.201.4 Testing in the event of non-extinguishing material</b></p> <p>If parts, other than enclosures, do not withstand the glow wire tests of 4.7.201.3, by failure to extinguish within 30 s after the removal of the glowwire tip, the needle-flame test detailed in 4.7.201.3 shall be made on all parts of non-metallic material which are within a distance of 50 mm or which are likely to be impinged upon by flame during the tests of 4.7.201.3. Parts shielded by a separate barrier which meets the needle-flame test need not be tested.</p> <p>NOTE 1 If the enclosure does not withstand the glow-wire test the equipment is considered to have failed to meet the requirements of Clause 4.7.201 without the need for consequential testing.</p> <p>NOTE 2 If other parts do not withstand the glow-wire test due to ignition of the tissue paper and if this indicates that burning or glowing particles can fall onto an external surface underneath the equipment, the equipment is considered to have failed to meet the requirements of Clause 4.7.201 without the need for consequential testing.</p> <p>NOTE 3 Parts likely to be impinged upon by the flame are considered to be those within the envelope of a vertical cylinder having a radius of 10 mm and a height equal to the height of the flame, positioned above the point of the material supporting, in contact with, or in close proximity to, connections.</p>		N/A						
4.7.201.5	<p><b>4.7.201.5 Testing of printed boards</b></p> <p>The base material of printed boards shall be subjected to the needle-flame test of Clause 4.7.201.3. The flame shall be applied to the edge</p>		N/A						

IEC60950_1F - ATTACHMENT			
Clause	Requirement + Test	Result - Remark	Verdict
	<p>of the board where the heat sink effect is lowest when the board is positioned as in normal use. The flame shall not be applied to an edge, consisting of broken perforations, unless the edge is less than 3 mm from a POTENTIAL IGNITION SOURCE.</p> <p>The test is not carried out if the —</p> <ul style="list-style-type: none"> <li>- Printed board does not carry any POTENTIAL IGNITION SOURCE;</li> <li>- Base material of printed boards, on which the available apparent power at a connection exceeds 15 VA operating at a voltage exceeding 50 V and equal or less than 400 V (peak) a.c. or d.c. under normal operating conditions, is of flammability category V-1 or better according to AS/NZS 60695.11.10, or the printed boards are protected by an enclosure meeting the flammability category V-0 according to AS/NZS 60695.11.10, or made of metal, having openings only for connecting wires which fill the openings completely; or</li> <li>- Base material of printed boards, on which the available apparatus power at a connection exceeds 15 VA operating at a voltage exceeding 400 V (peak) a.c. or d.c. under normal operating conditions, and base material of printed boards supporting spark gaps which provides protection against overvoltages, is of flammability category V-0 according to AS/NZS 60695.11.10 or the printed boards are contained in a metal enclosure, having openings only for connecting wires which fill the openings completely.</li> </ul> <p>Compliance shall be determined using the smallest thickness of the material.</p> <p>NOTE Available apparent power is the maximum apparent power which can be drawn from the supplying circuit through a resistive load whose value is chosen to maximise the apparent power for more than 2 min when the circuit supplied is disconnected.</p>		
6.2.2	<p>For Australia only, delete the first paragraph and Note, and replace with the following:</p> <p>In Australia only, compliance with 6.2.2 shall be checked by the tests of both 6.2.2.1 and 6.2.2.2.</p>	No TNV.	<b>N/A</b>

IEC60950_1F - ATTACHMENT			
Clause	Requirement + Test	Result - Remark	Verdict
6.2.2.1	<p>For Australia only, delete the first paragraph including the Notes, and replace with the following:</p> <p><i>In Australia only, the electrical separation is subjected to 10 impulses of alternating polarity, using the impulse test generator reference 1 of Table N.1. The interval between successive impulses is 60 s and the initial voltage, <math>U_c</math>, is:</i></p> <p><i>(i) for 6.2.1 a): 7.0 kV for hand-held telephones and for headsets and 2.5 kV for other equipment; and</i></p> <p><i>(ii) for 6.2.1 b) and 6.2.1 c): 1.5 kV.</i></p> <p>NOTE 201 The 7 kV impulse simulates lightning surges on typical rural and semi-rural network lines.</p> <p>NOTE 202 The value of 2.5 kV for 6.2.1 a) was chosen to ensure the adequacy of the insulation concerned and does not necessarily simulate likely overvoltages.</p>	No TNV.	<b>N/A</b>
6.2.2.2	<p>For Australia only, delete the second paragraph including the Note, and replace with the following:</p> <p><i>In Australia only, the a.c. test voltage is:</i></p> <p><i>(i) for 6.2.1 a): 3 kV; and</i></p> <p><i>(ii) for 6.2.1 b) and 6.2.1 c): 1.5 kV.</i></p> <p>NOTE 201 Where there are capacitors across the insulation under test, it is recommended that d.c. test voltages are used.</p> <p>NOTE 202 The 3 kV and 1.5 kV values have been determined considering the low frequency induced voltages from the power supply distribution system.</p>	No TNV.	<b>N/A</b>
7.3	<p>Add the following before the first paragraph:</p> <p>Equipment providing functions that fall only within the scope of AS/NZS 60065 and that incorporate a PSTN interface, are not required to comply with this Clause where the only ports provided on the equipment, in addition to a coaxial cable connection and a PSTN interface, are audio or video ports and analogue or data ports not intended to be used for telecommunications purposes.</p>	Not connected to cable distribution system.	<b>N/A</b>
Annex P	<p>Normative references</p> <p>(List of relevant Australia/New Zealand Standards that have been inserted in place of some of the International Standards)</p>		<b>N/A</b>

IEC60950_1F - ATTACHMENT			
Clause	Requirement + Test	Result - Remark	Verdict
Appendix	J60950-1(H26) (Deviations from IEC 60950-1:2005 (2nd edition)) Interpretation for METI Ordinance of Technical Requirements (H26.04.14), Appendix 12		—
1.2	Addition: Add the following terms. Equipment, Class 0I 1.2.4.3A		N/A
1.2.4.1	Add the following new notes. Note 2: Even if the equipment is designed as Class I, the equipment is regarded as Class 0I equipment when 2-pin adaptor with earthing lead wire or cord set having 2-pin plug with earthing lead wire is provided or recommended.		N/A
1.2.4.3A	Add the following new clause. 1.2.4.3A CLASS 0I EQUIPMENT Equipment having attachment plug without earthing blade, where protection against electric shock is achieved by: - using BASIC INSULATION, and - providing externally an earth terminal or a lead wire for earthing in order to connect those conductive parts that might assume a HAZARDOUS VOLTAGES in the event of BASIC INSULATION fault to the PROTECTIVE EARTHING CONDUCTOR in the building wiring. NOTE – Class 0I equipment may have a part constructed with Double Insulation or Reinforced Insulation circuit.		N/A
1.3.2	Add the following notes after first paragraph: Note 1 Transportable or similar equipment that are relocated frequently for intended usage should not be designed as Class I or Class 0I equipment unless it is intended to be installed by service personnel. Note 2 Considering wiring circumstance in Japan, equipment intended to be installed where the provision for earthing connection is unlikely should not be designed as Class I or Class 0I equipment unless it is intended to be installed by service personnel.		N/A
1.5.1	Replace the first paragraph with the follows: Where safety is involved, components shall comply either with the requirements of this standard, with the safety aspects of the relevant JIS component standard, or IEC component standards in case there is no applicable JIS component standard is available. However, a component that falls within the scope of METI Ministerial ordinance No. 85 is properly used in accordance with its marked ratings, requirements of 1.5.4, 2.8.7 and 3.2.5 apply, and in addition, a cord connector of power supply cord set mating with appliance inlet complying with the standard sheet of IEC 60320-1,	Replaced.	N/A

IEC60950_1F - ATTACHMENT			
Clause	Requirement + Test	Result - Remark	Verdict
	shall comply with relevant standard sheet of IEC 60320-1. Replace Note 1 with the following: Note 1 A JIS or an IEC component standard is considered relevant only if the component in question clearly falls within its scope.		
1.5.2	Replace first sentence in the first dashed paragraph with the following: - a component that has been demonstrated to comply with a JIS component standard harmonized with the relevant IEC component standard, or where such JIS component standard is not available, a component that has been demonstrated to comply with the relevant IEC component standard shall be checked for correct application and use in accordance with its rating. Add a note after the third dashed paragraph as follows: Note 1 See 1.7.5A when Type C.14 appliance coupler rated 10 A per IEC 60320-1 is used with an equipment rated not more than 125 V and rated more than 10 A. Replace first sentence in the third dashed paragraph as follows: - where no relevant IEC component standard or JIS component standard harmonized with the relevant IEC component standard exists, or where components are used in circuits not in accordance with their specified rating, the components shall be tested under the conditions occurring in the equipment.	Considered.	N/A
1.5.9.1	Where surge suppressor used in primary circuits, it may provide VDR in series connection of gas discharge tube.	No gas discharge tube.	N/A
1.5.9.4	Gas discharge tube may connect in series of VDR for functional insulation.		N/A
1.7.1	Replace fifth dashed paragraph with the following: - manufacturer's or responsible company's name or trade-mark or identification mark;	Added.	N/A
1.7.2.1	Safety relevant instructions and markings on the apparatus require in Japanese letter		N/A
1.7.5	Replacement: "IEC/TR 60083 replaced with JIS C 8303".	No such outlets.	N/A
1.7.5A	Add the following new clause. After 1.7.5: 1.7.5A Appliance Coupler If appliance coupler according to IEC 60320-1, C.14 (rated current: 10A) is used in equipment whose rated voltage is less than 125V and rated current is over 10A, the following instruction or equivalent shall be described in the user instruction. „Use only designated cord set attached in this equipment”	Power cord set is not provided.	N/A



IEC60950_1F - ATTACHMENT			
Clause	Requirement + Test	Result - Remark	Verdict
	<i>Example in Japanese:</i> 「この機器に同こん(梱)した指定の電源コードセットだけを使用してください。」		
1.7.14A	Add the following new clause. After 1.7.14: 1.7.17A Marking for CLASS 0I EQUIPMENT For CLASS 0I EQUIPMENT, the following instruction shall be marked on the visible place of the mains plug or the main body: “Provide an earthing connection” <i>Example in Japanese:</i> 「必ず接地接続を行ってください。」 Moreover, for CLASS 0I EQUIPMENT, the following or equivalent instruction shall be indicated on the visible place of the main body or written in the operating instructions: “Provide an earthing connection before the mains plug is connected to the mains. And, when disconnecting the earthing connection, be sure to disconnect after pulling out the mains plug from the mains.” <i>Example in Japanese:</i> 「接地接続は必ず、電源プラグを電源につなぐ前に行ってください。また、接地接続を外す場合は、必ず電源プラグを電源から切り離してから行ってください。」		N/A
1.7.14B	Add the following new clause: Protective earthing wire for Class 0I equipment.		N/A
2.1.1.1 b)	Replacement: “IEC 60083” replaced with “JIS C 8303 or technical requirements of MITI Ordinance No. 85”.	Replaced.	N/A
2.6.3.2	Add the following: This also applies to the conductor of lead wire for protective earthing of CLASS 0I EQUIPMENT. Where single core wire shall be as followings; - 1.6mm diameter of soft copper wire, or equivalent strength and thickness, with no easily corrosion metal wire. -, Single core code or single core cabtyre cable with cross sectional area over 1.25mm <sup>2</sup> .		N/A
2.6.3.5	Color of power cord shall not apply inner conductor with covering a sheath for unified power cord (cord set) with plug and connector.		N/A
2.6.4.2	Equipment required to have protective earthing shall have a main protective earthing terminal. For equipment with a DETACHABLE POWER SUPPLY CORD, the earthing terminal in the appliance inlet is regarded as the main protective earthing terminal except for CLASS 0I EQUIPMENT providing separate main protective earthing terminal other than appliance inlet.		N/A
2.6.5.4	Replace the first sentence with the following: Protective earthing connections of CLASS I		N/A

IEC60950_1F - ATTACHMENT			
Clause	Requirement + Test	Result - Remark	Verdict
	EQUIPMENT shall make earlier and break later than the supply connections.		
2.6.5.6	Add the following: "Protective bonding terminal" as a terminal required a corrosion proof.		N/A
2.6.5.8A	Add the following new clause. after 2.6.5.8: 2.6.5.8A Earthing of CLASS 0I EQUIPMENT Plugs with a lead wire for earthing shall not be used for equipment having a rated voltage exceeding 150V. For plugs with a lead wire for earthing, the lead wire shall not be earthed by a clip. CLASS 0I EQUIPMENT shall be provided with an earthing terminal or lead wire for earthing in the external location where easily visible.		N/A
2.9.3 Table 2H	Deleted the following mark of Figure 2H: B13 e) and S2 d)		N/A
2.9.3 Figure 2H	Addition of marking for table 2H: B8, B9, B12, B13, S1		N/A
2.10.3.1	Add the followings after fifth dashed paragraph: Minimum crealance distances not apply following connectors -, Applicable connector for series of JIS C 8285, IEC 60309, JIS C 8283, IEC 60320 or JIS C 8303. -, Applicable connectors for "technical requirements of MITI Ordinance No. 85" and conform the dimension regulation or series of JIS C 8283, JIS C 8303 or IEC 60309-2.	Replaced.	N/A
2.10.3.3 Table 2L	Addition of interpolation and round-up unit of clearance distance 0.1mm.		N/A
2.10.4.3	Add the followings after third dashed paragraph: minimum creepage distances not apply following connectors -, Applicable connector for series of JIS C 8285, IEC 60309, JIS C 8283, IEC 60320 or JIS C 8303. -, Applicable connectors for "technical requirements of MITI Ordinance No. 85" and conform the dimension regulation and series of JIS C 8283, JIS C 8303 or IEC 60309-2.		N/A
2.10.9	Addition of reference measurement method for T <sub>1</sub> : clause 1.4.12		N/A
3.2.1.1	Add the following after third dashed paragraph: Reference for clause 1.7.5A about marking of power supply cord set.		N/A
3.2.3	Add the following after Table 3A: Table 3A applies when cables complying JIS C 3662 or JIS C 3663 are used. In case of other cables, cable entries shall be so designed that a conduit suitable for the cable used can be fitted.	Not such equipment.	N/A

IEC60950_1F - ATTACHMENT			
Clause	Requirement + Test	Result - Remark	Verdict
3.2.4	When equipment provides with appliance inlet complying with JIS C 8283-1(2008), soldered parts of appliance inlet is not applied by force during insert or removal of connector. This is not applied when inlet body is fixed itself and not fixed by solder.		N/A
3.2.5.1	Add the following to the last of first dashed paragraph: Or mains cords shall be of the sheathed type complying with Appendix 1 of Article 1 of the Ministerial Ordinance on stipulating technical requirements for the Electrical Appliance. Add the following to the last of second dashed paragraph: Or mains cords shall be of the sheathed type complying with Appendix 1 of Article 1 of the Ministerial Ordinance on stipulating technical requirements for the Electrical Appliance. Add the following to the third dashed paragraph: But, Cover of inner protective earthing conductor with covering by sheath for unified power cord (cord set) with plug and connector shall not be combination of Green/Yellow. Add the following to the fifth dashed paragraph: Except for the wire for JIS C 3662-5 or JIS C 3663-4 shall be conform relevant wiring regulations.	No mains cord provided.	N/A
3.3 Table 3D	Add the following note: Where use of wire except for JIS C 3662 series or JIS C 3663 series, terminal connected to wire shall be proper dimension.		N/A
3.3.7	Add the following after the first sentence: This requirement is not applicable to the external earthing terminal of Class 0I equipment.	No such terminals.	N/A
4.3.4	Add the following after the first sentence: This requirement also applies to those connections in Class 0I equipment, where CLEARANCE or CREEPAGE DISTANCES over BASIC INSULATION would be reduced to less than the values specified in 2.10.	No such parts.	N/A
4.3.5	Add the following standard: JIS C 8303 or JIS C 8358		N/A
4.5.3 Table 4B	Add the following: Where no data for the material in Note b).		N/A
5.1.3	Add a note after the first sentence as follows: Note – Attention should be drawn to that majority of three-phase power system in Japan is of delta connection, and therefore, in that case, test is conducted using the test circuit from IEC 60990, figure 13.	Single phase equipment.	N/A

IEC60950_1F - ATTACHMENT				
Clause	Requirement + Test	Result - Remark	Verdict	
5.1.6	Replace Table 5A. as follows:		N/A	
	Type of equipment	Terminal A of measuring instrument connected to:	Maximum TOUCH CURRENT mA r.m.s. <sup>1)</sup>	Maximum PROTECTIVE CONDUCTOR CURRENT
	ALL equipment	ALL equipment Accessible parts and circuits not connected to protective earth	0.25	--
	HAND-HELD	Equipment main protective earthing terminal of CLASS I EQUIPMENT	0.75	--
		Equipment main protective earthing terminal of CLASS 0I EQUIPMENT	0.5	--
	MOVABLE (other than HAND-HELD, but including TRANSPORTABLE EQUIPMENT)	Equipment main protective earthing terminal of CLASS I EQUIPMENT	3.5	--
		Equipment main protective earthing terminal of CLASS 0I EQUIPMENT	1.0	--
	STATIONARY, PLUGGABLE TYPE A	Equipment main protective earthing terminal of CLASS I EQUIPMENT	3.5	--
		Equipment main protective earthing terminal of CLASS 0I EQUIPMENT	1.0	--
	ALL other STATIONARY EQUIPMENT - not subject to the conditions of 5.1.7 - subject to the conditions of 5.1.7	Equipment main protective earthing terminal of CLASS I EQUIPMENT	3.5 --	-- 5% of input current
		Equipment main protective earthing terminal of CLASS 0I EQUIPMENT	1.0 --	-- --
	Note a) If peak values of TOUCH-CURRENT are measured, the maximum values obtained by multiplying the r.m.s. values by 1.414. b) Accessible part of non earthing part shall be apply clause 1.5.6, 1.5.7 and 2.4. These may differ clause 5.1.6.			
	6	Addition: Following sentence added last part of note 1; "Refer to Annex JB for proper action.	No TNV circuits.	N/A
	6.1.2.1	Add the note 3 as follows: For example, 230V for EU, 120V for North America		N/A
Annex G.6	Add the paragraph as follows: Above minimum clearance is not apply following connector. Also refer clause 1.5.2 -, Applicable connector for JIS C 8285, IEC 60309 series, JIS C 8283 series, IEC 60320 series or JIS C 8303 series.		N/A	

IEC60950_1F - ATTACHMENT			
Clause	Requirement + Test	Result - Remark	Verdict
	-, Applicable connectors for “technical requirements of MITI Ordinance No. 85” and conform the dimension regulation and series of JIS C 8283, JIS C 8303 or IEC 60309-2.		
Annex M.1	Change to note as follows: Choose method A or method B Method A for EU, Method B for North America		N/A
Annex P	Replacement: “IEC 61051-2:1991” replaced with “ IEC 61051-2“		N/A
Annex U.2.4	Deleted: “Example: 1.1.1-trichloroethane“		N/A
Annex V.1	Correction: “IEC 60364-1, clause 3.1.2“ replaced with “ IEC 60364-1, clause 312“		N/A
Annex W.1	Replace second and third sentence in the first paragraph with the following: This distinction between earthed and unearthed (floating) circuit is not the same as between CLASS I EQUIPMENT, CLASS 0I EQUIPMENT and CLASS II EQUIPMENT. Floating circuits can exist in CLASS I EQUIPMENT or CLASS 0I EQUIPMENT and earthed circuits in CLASS II EQUIPMENT.	Not applied.	N/A
Annex AA	Added the following figure: Fig. AA.3 – End location of the mandrel.		N/A
Annex JA	Add a new annex JA with the following contents: Annex JA (normative) Document shredding machines Document shredding machines shall also comply with the requirements of this annex except those of STATIONARY EQUIPMENT used by connecting directly to an AC MAINS SUPPLY of three-phase 200V or more.	See below information.	-
JA.1	<u>Markings and instructions</u>  (JIS S 0101:2000, 6.2.4) and the following precautions for use shall be marked on readily visible part adjacent to document feed opening. The marking shall be clearly legible, permanent, and easily discernible; - that use by an infants/children may cause a hazard of injury etc.; - that a hand can be drawn into the mechanical section for shredding when touching the document-slot; - that clothing can be drawn into the mechanical section for shredding when touching the document-slot; - that hairs can be drawn into the mechanical section for shredding when touching the	Not Document shredding machines.	N/A

IEC60950_1F - ATTACHMENT			
Clause	Requirement + Test	Result - Remark	Verdict
	document-slot; - in case of equipment incorporating a commutator motor, that equipment may catch fire or explode by spraying of flammable gas.		
JA.2	<u>Inadvertent reactivation</u> Any safety interlock that can be operated by means of the test finger, Figure JA.1, is considered to be likely to cause inadvertent reactivation of the hazard. Compliance is checked by inspection and, where necessary, by a test with the test finger, Figure JA.1.		N/A
JA.3	<u>Disconnection from the mains supply</u> Document shredding machines shall incorporate an isolating switch complying with sub-clause 3.4.2 as the device disconnecting the power of hazardous moving parts. For this switch, two-position (single-use) switch or multi-position (multifunction) switch (e.g., slide switch) may be used. If two-position switch, the positions for "ON" and "OFF" shall be indicated in accordance with sub-clause 1.7.8. If multi-position switch, the position for "OFF" shall be indicated in accordance with sub-clause 1.7.8 and other positions shall be indicated with proper terms or symbols. Compliance is checked by inspection.		N/A
JA.4	<u>Protection against hazardous moving parts</u> Any warning shall not be used instead of the structure for preventing access to hazardous moving parts. Document shredding machines shall comply with the following requirements.  Insert the test finger, Figure JA.1, into all openings in MECHANICAL ENCLOSURES without applying appreciable force. It shall not be possible to touch hazardous moving parts with the test finger. This consideration applies to all sides of MECHANICAL ENCLOSURES when the equipment is mounted as intended. Before testing with the test finger, remove the parts detachable without a tool.  Insert the wedge-probe, Figure JA.2, into the document-slot. And, against all directions of openings, if straight-cutting type, a force of 45 N shall apply to the probe, and 90 N if cross-cutting type. In this case, the weight of the probe is to be factored into the overall applied force. Before testing with the wedge-probe, remove the parts detachable without a tool. It shall not be possible to touch any hazardous moving parts, including the shredding roller or the mechanical section for shedding, with the probe.		N/A

IEC60950\_1F - ATTACHMENT

Clause	Requirement + Test	Result - Remark	Verdict
--------	--------------------	-----------------	---------

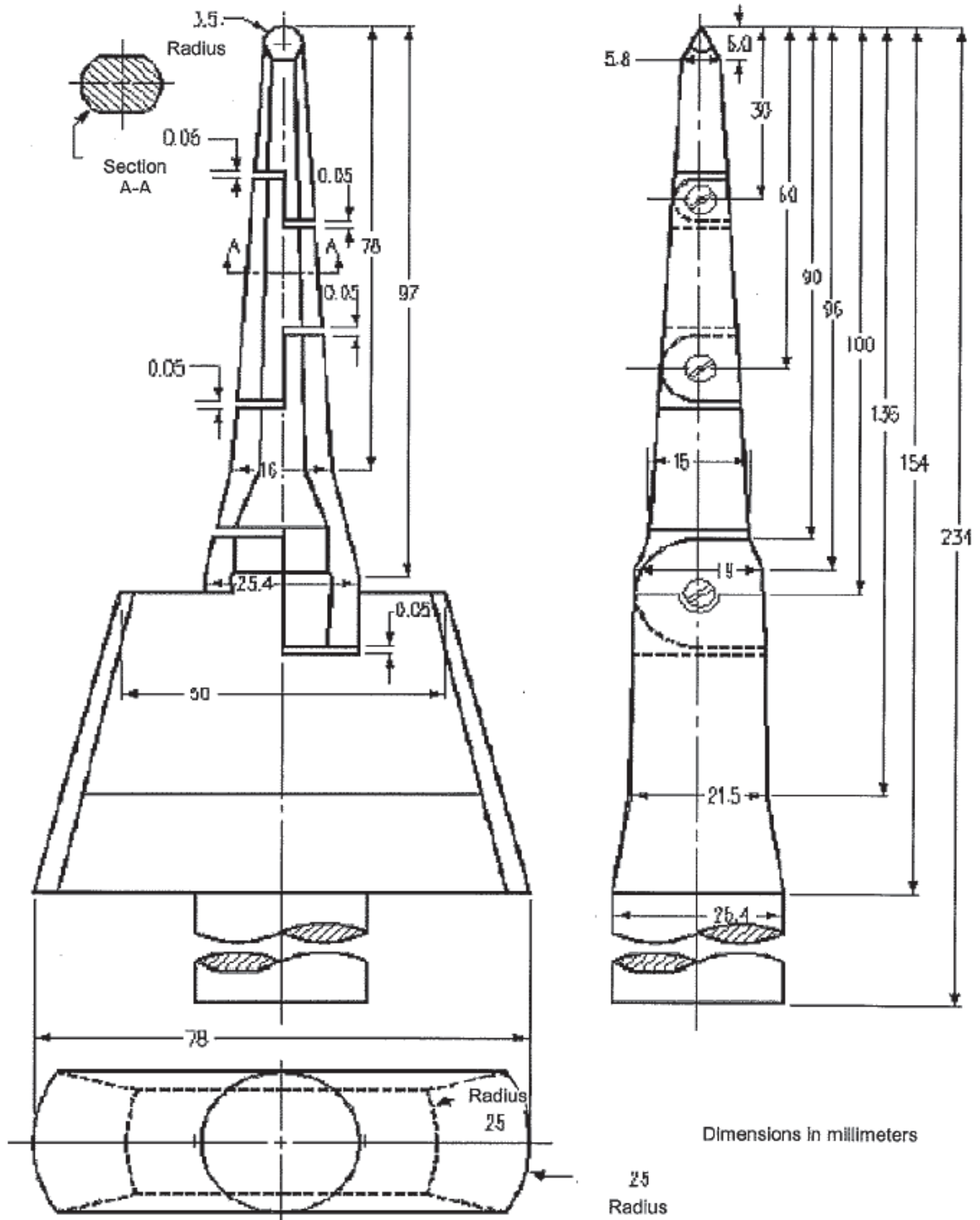
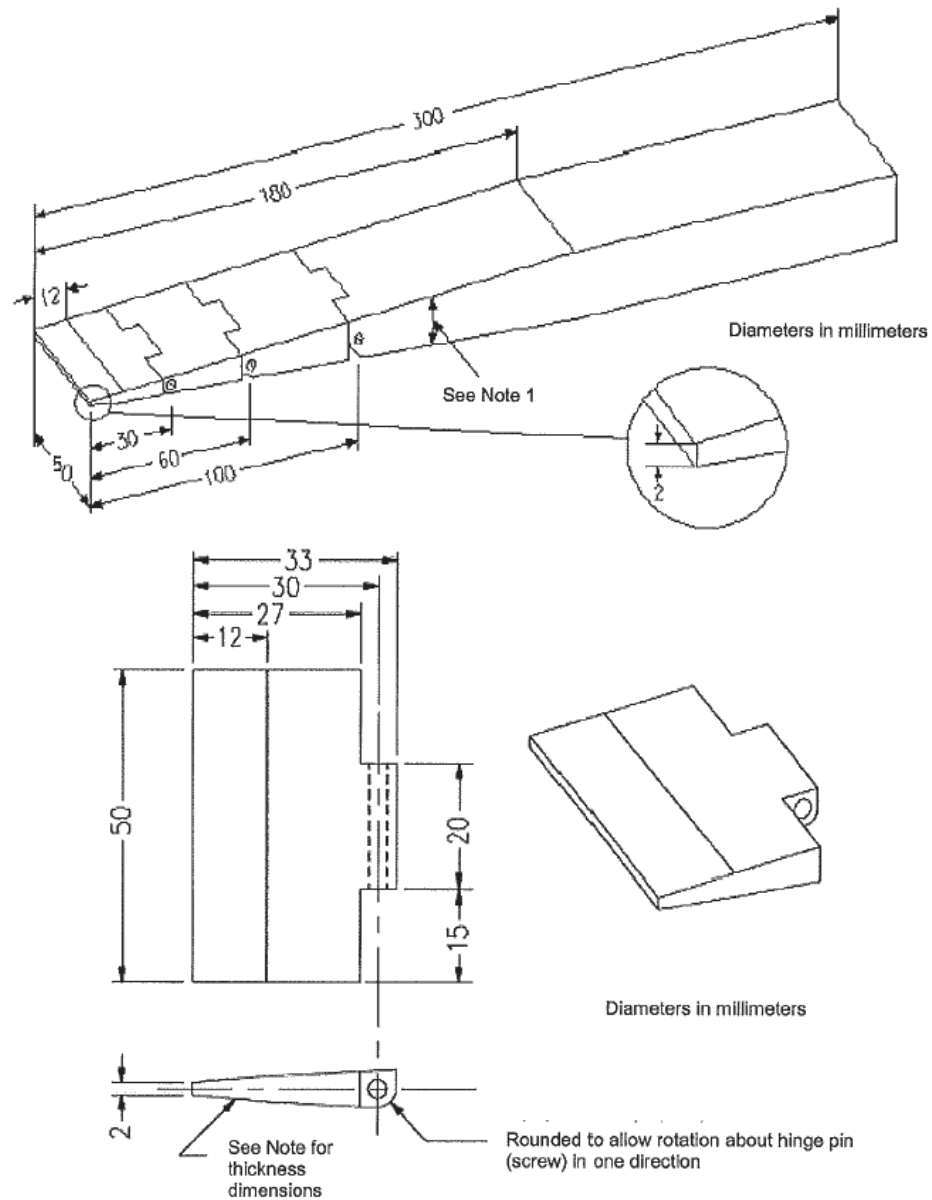

Figure JA.1 Test finger

IEC60950_1F - ATTACHMENT			
Clause	Requirement + Test	Result - Remark	Verdict



(Details of the top of wedge)

<i>Distance from the tip (mm)</i>	<i>Thickness of probe (mm)</i>
0	2
12	4
180	24

Note 1 The thickness of the probe varies linearly, with slope changes at the respective points shown in the table.

Note 2 The allowable dimensional tolerance of the probe is +/- 0.127 mm.

**Figure JA.2 Wedge-probe**



IEC60950_1F - ATTACHMENT			
Clause	Requirement + Test	Result - Remark	Verdict
Annex JB	Add a new annex JB with the following contents: Annex JB (informative) Present status and management method of the placing environment on the overvoltage and overcurrent (Refer to note 1 of clause 6)		--
JB.1	Preferable placing environment.		N/A
JB.2	Present status and management method of the placing environment on the Overvoltage and Overcurrent.		N/A
Reference literature	Add the following literature: <a href="http://www.jisc.go.jp/">http://www.jisc.go.jp/</a> ITU-T Recommendation K.66:2004, Protection of customer premises from overvoltages		N/A

IEC60950_1F - ATTACHMENT			
Clause	Requirement + Test	Result - Remark	Verdict
Appendix	J3000(H25) Interpretation for METI Ordinance of Technical Requirements (H26.04.14), Appendix 12		—
1	General requirement When equipment provides with appliance inlet complying with JIS C 8283-1(2008), soldered parts of appliance inlet is not applied by force during insert or removal of connector. This is not applied when inlet body is fixed itself and not fixed by solder.		N/A
2	Requirement for equipment		—
2.1	Heater Appliances When diode is used in parallel for adjustment of power, the equipment shall remain safe for operation under open condition of one diode.	Not electric stove.	N/A
	The current rating of one diode shall be more than main current. The diodes connected in parallel are same type.		N/A
	The heating test specified by clause 11 of JIS C 9335-2-30(2006) under open condition of one diode shall comply with the requirements.		N/A
2.2	Electric heater with glowing heating elements	Not electric stove.	N/A
	Surface treatment by paint or adhesive on protective frame or protective mesh shall not be used.		N/A
	Caution marking like below shall be on - easily visible place of the equipment or - Instruction manual 「注意 当該機器から、使用初期段階で揮発性有機化合物及びカルボニル化合物が最も放散するおそれがあるため、その際には十分換気を行うこと。」		N/A
3	Components used in equipment	No such equipment /components.	N/A

IEC60950_1F - ATTACHMENT			
Clause	Requirement + Test	Result - Remark	Verdict
3.1	Motor capacitors used in ventilating fan, electric fan, air conditioner, electric washing machine, refrigerator or electric freezer shall be comply with <ul style="list-style-type: none"> <li>- capacitors with protective elements or protective mechanism complying with JIS C 4908(2007)</li> <li>- P2 capacitor complying with IEC 60252-1(2001)</li> </ul> Capacitor complying with below is acceptable		N/A
	Enclosed by metal or ceramic		N/A
	No non-metallic materials within 50 mm from capacitor surface		N/A
	Non-metallic material within 50 mm from capacitor surface comply with needle frame test of JIS C 9335-1(2003), Annex E		N/A
	Non-metallic material within 50 mm from capacitor surface comply with V-1 test of JIS C 60965-11-10(2006).		N/A
3.2	Plug directly inserted to outlet used refrigerator or electric freezer. Shall comply with <ul style="list-style-type: none"> <li>- Face contact with outlet shall have CTI with more than 400 according to JIS C 2134(2007) or</li> <li>- Supporting material of blades shall comply with glow wire test by temperature of 750°C according to JIS C 60695-2-11(2004) or JIS C 60695-2-12(2004).</li> </ul> Materials having glow wire frame temperature of 775 °C are acceptable.		N/A

**Type Designation:** \*\*271\*\*\*\*, 270LM000\*\* (\* can be 0-9, A-Z, a-z, -, \, /, + or blank, represent different enclosure colour and sales regions for marketing purpose only, no technical difference.)

**Report Number:** 17056170 001



Figure 1. Front view



Figure 2. Rear view

Type Designation: \*\*271\*\*\*\*, 270LM000\*\* (\* can be 0-9, A-Z, a-z, -, \, /, + or blank, represent different enclosure colour and sales regions for marketing purpose only, no technical difference.)  
Report Number: 17056170 001



Figure 3. Top view

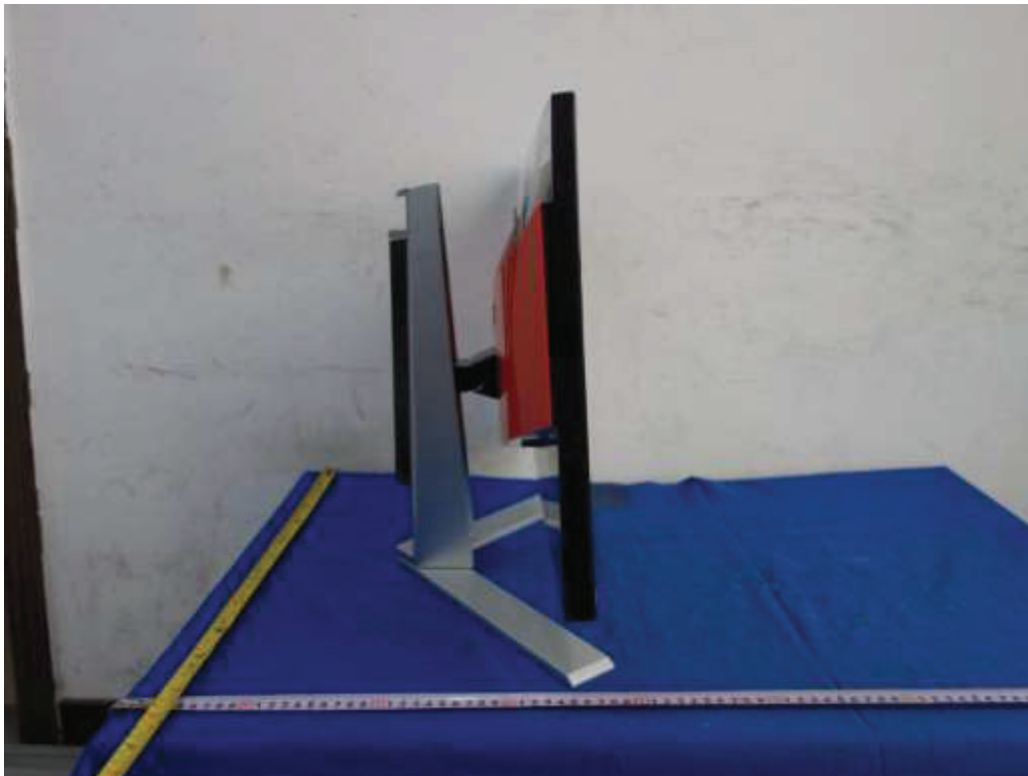

Figure 4. Side view

Type Designation: **\*\*271\*\*\*\*\*, 270LM000\*\*** (\* can be 0-9, A-Z, a-z, -, \, /, + or blank, represent different enclosure colour and sales regions for marketing purpose only, no technical difference.)

Report Number: **17056170 001**

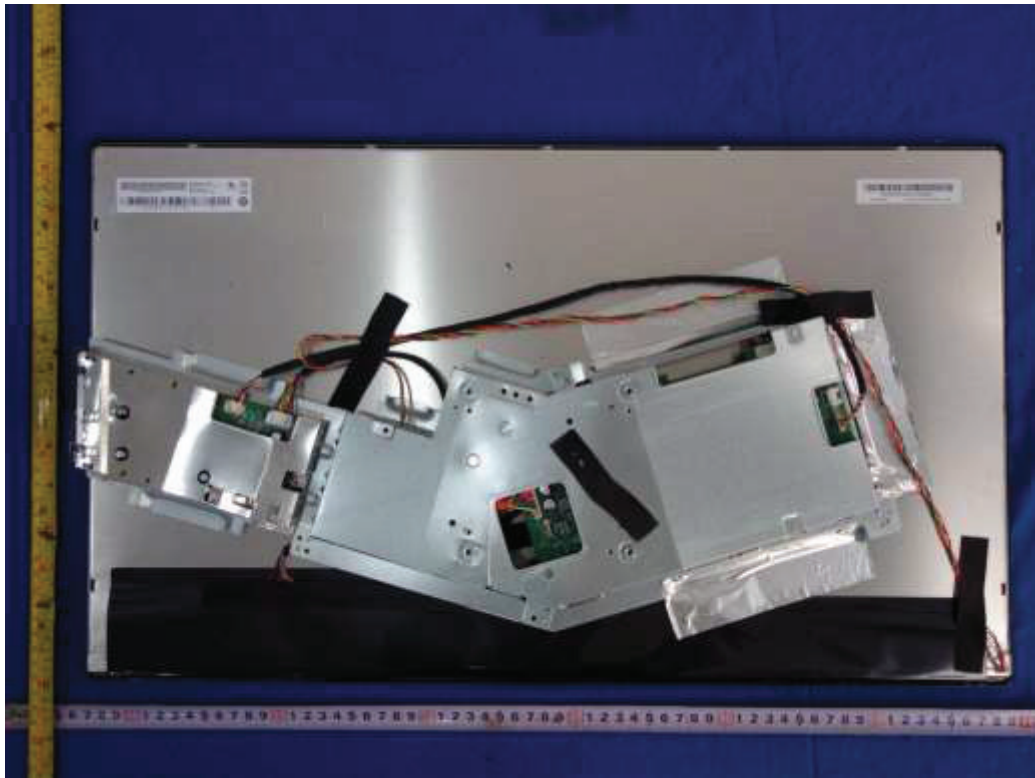

Figure 5. Metal enclosure



Figure 6. Metal enclosure

Type Designation: \*\*271\*\*\*\*, 270LM000\*\* (\* can be 0-9, A-Z, a-z, -, \, /, + or blank, represent different enclosure colour and sales regions for marketing purpose only, no technical difference.)

Report Number: 17056170 001



Figure 7. Metal enclosure

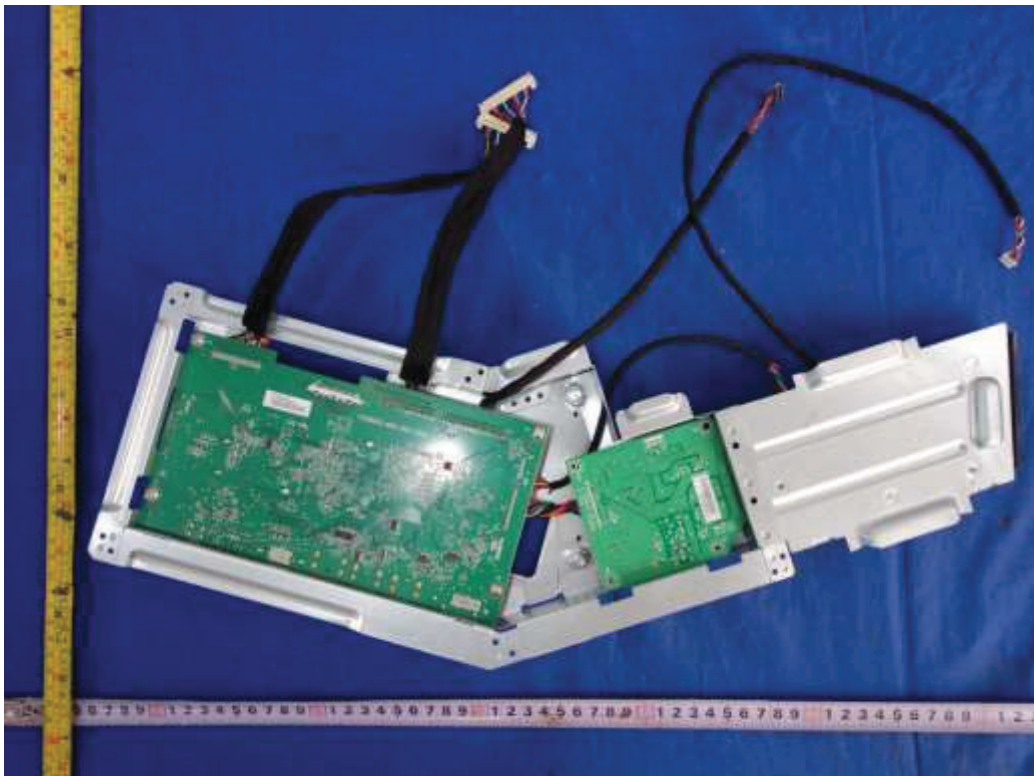

Figure 8. Internal view

Type Designation: \*\*271\*\*\*\*, 270LM000\*\* (\* can be 0-9, A-Z, a-z, -, \, /, + or blank, represent different enclosure colour and sales regions for marketing purpose only, no technical difference.)

Report Number: 17056170 001

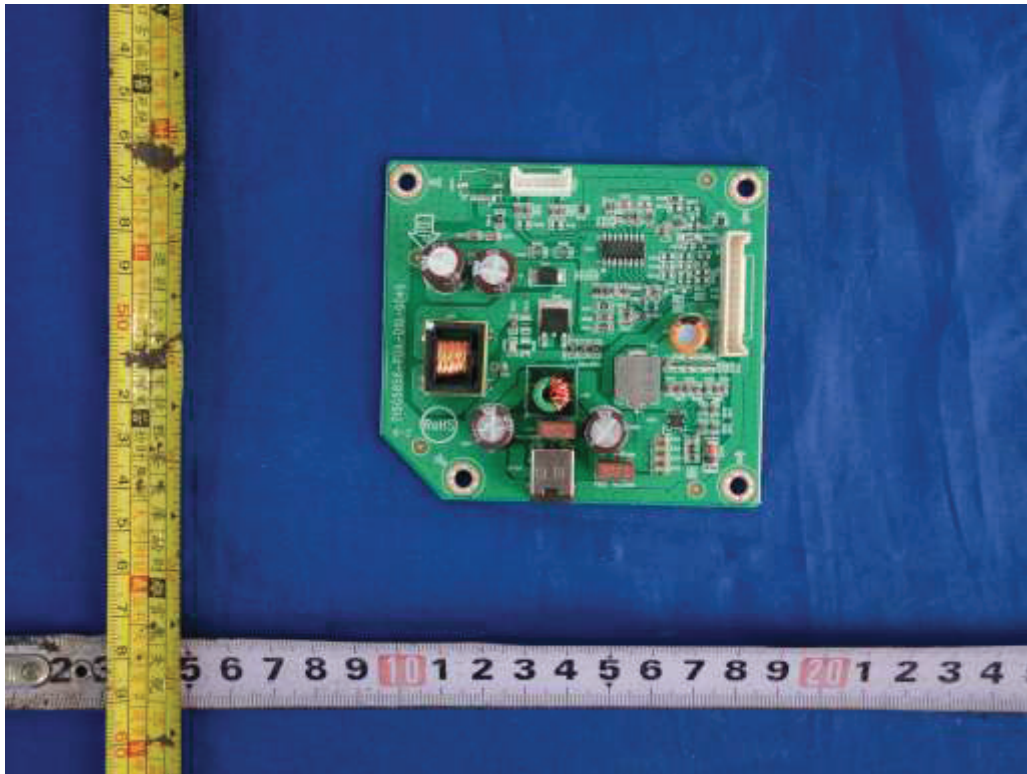

Figure 9. DC/DC converter board 715G5858

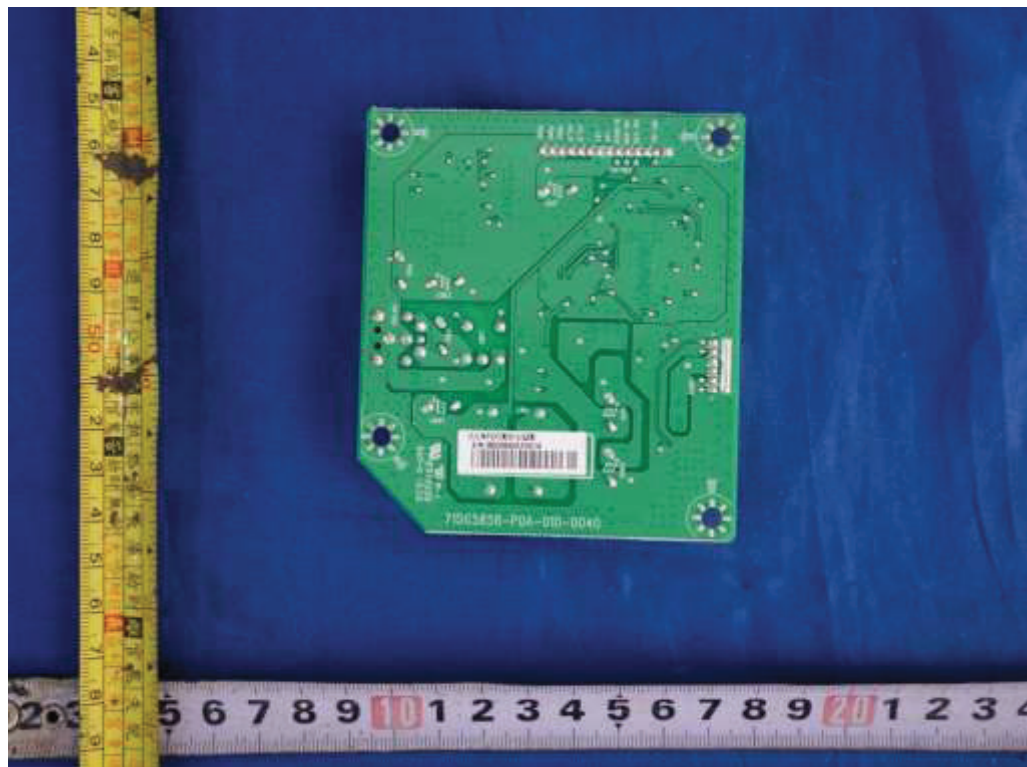

Figure 10. DC/DC converter board 715G5858



Type Designation: **\*\*271\*\*\*\*, 270LM000\*\*** (\* can be 0-9, A-Z, a-z, -, \, /, + or blank, represent different enclosure colour and sales regions for marketing purpose only, no technical difference.)

Report Number: **17056170 001**

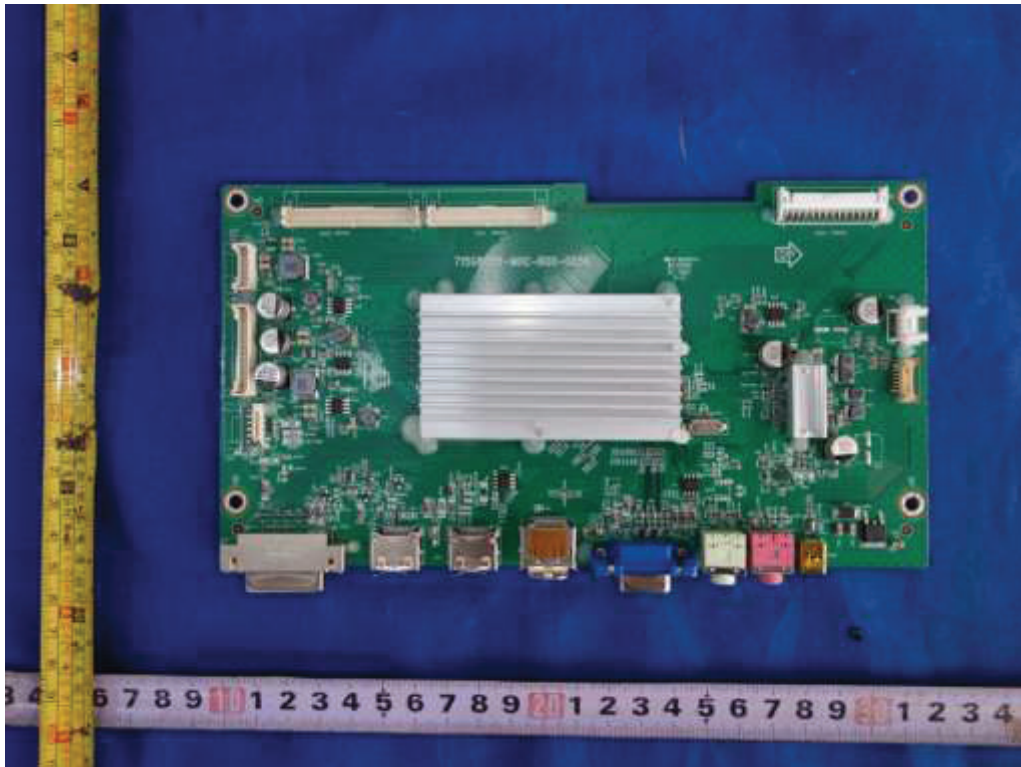

Figure 11. Main board 715G8055

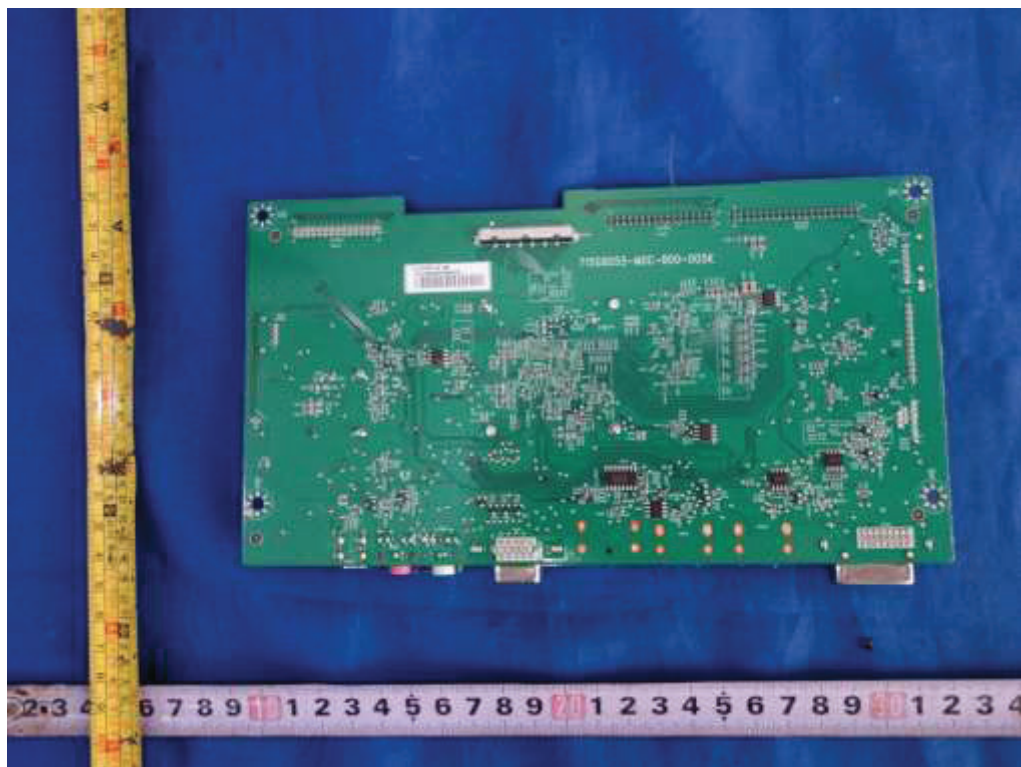

Figure 12. Main board 715G8055

Type Designation: **\*\*271\*\*\*\*\*, 270LM000\*\*** (\* can be 0-9, A-Z, a-z, -, \, /, + or blank, represent different enclosure colour and sales regions for marketing purpose only, no technical difference.)

Report Number: **17056170 001**

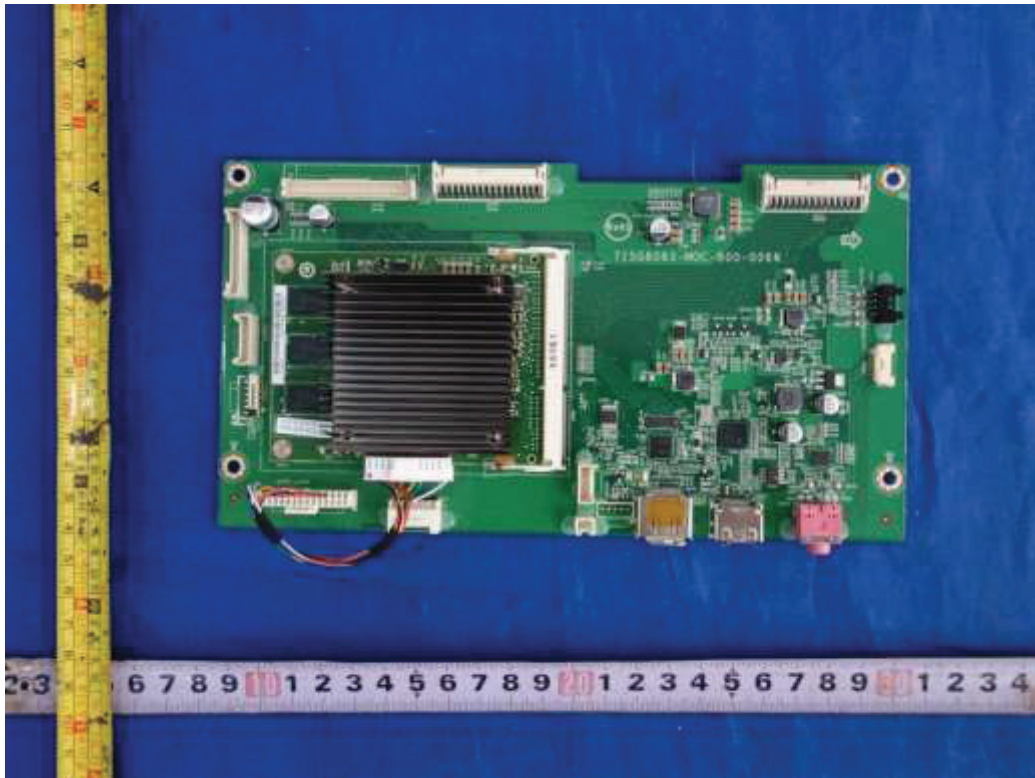

Figure 13. Main board 715G8083

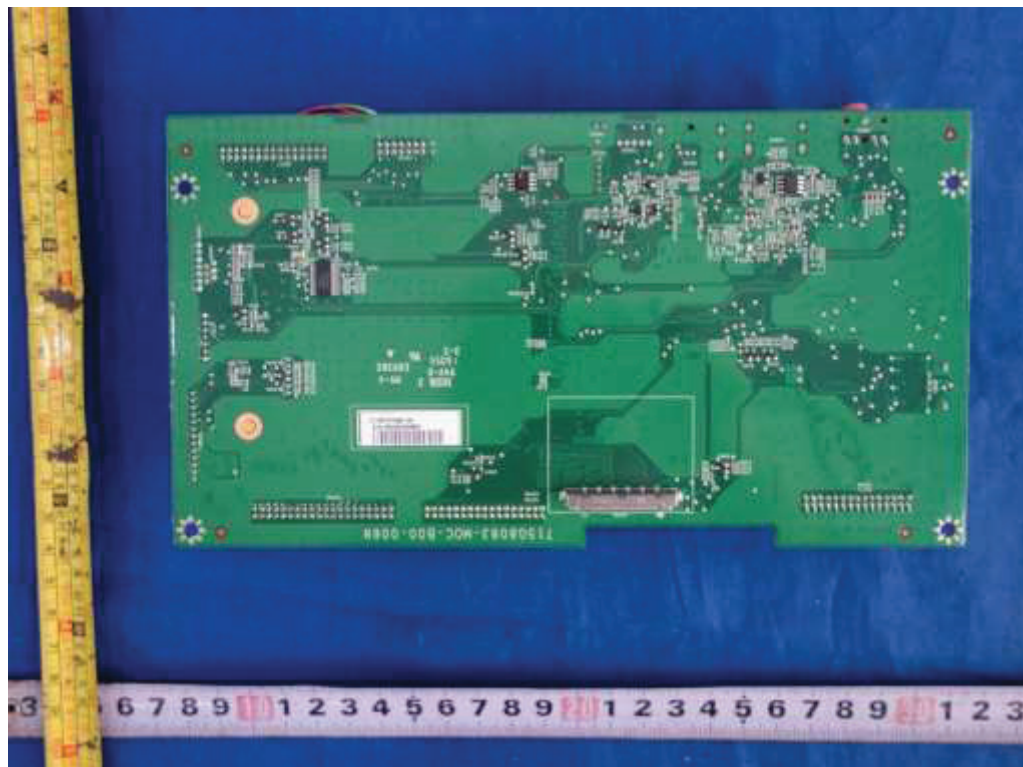

Figure 14. Main board 715G8083

Type Designation: \*\*271\*\*\*\*, 270LM000\*\* (\* can be 0-9, A-Z, a-z, -, \, /, + or blank, represent different enclosure colour and sales regions for marketing purpose only, no technical difference.)

Report Number: 17056170 001

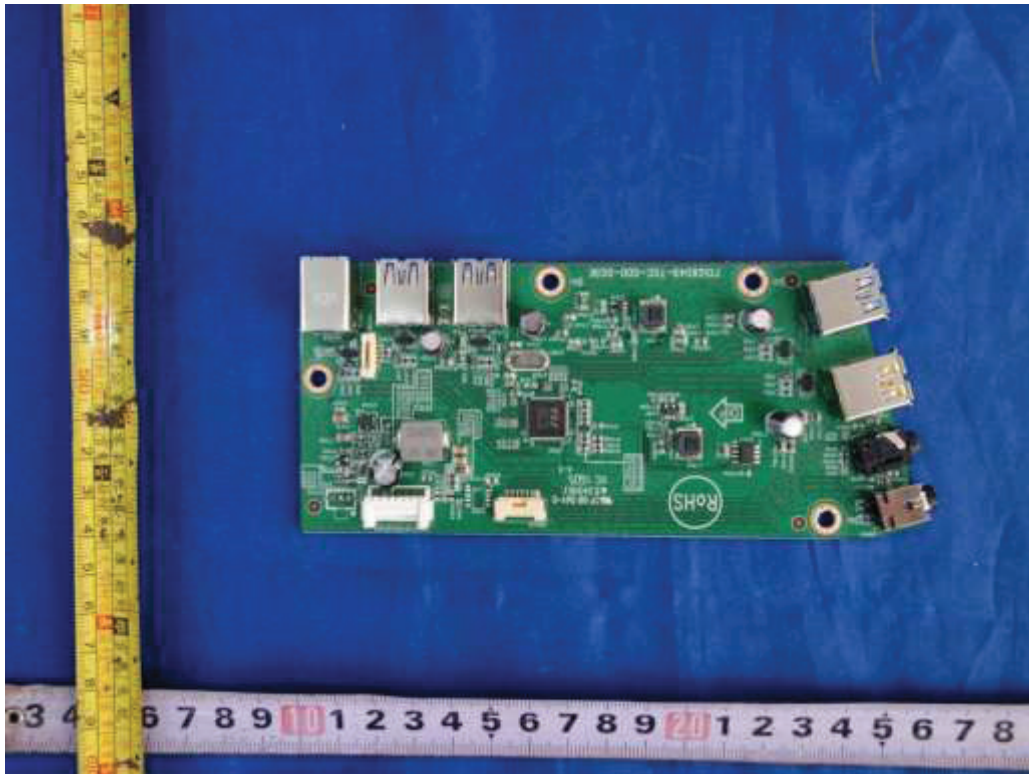

Figure 15. USB board 715G8049

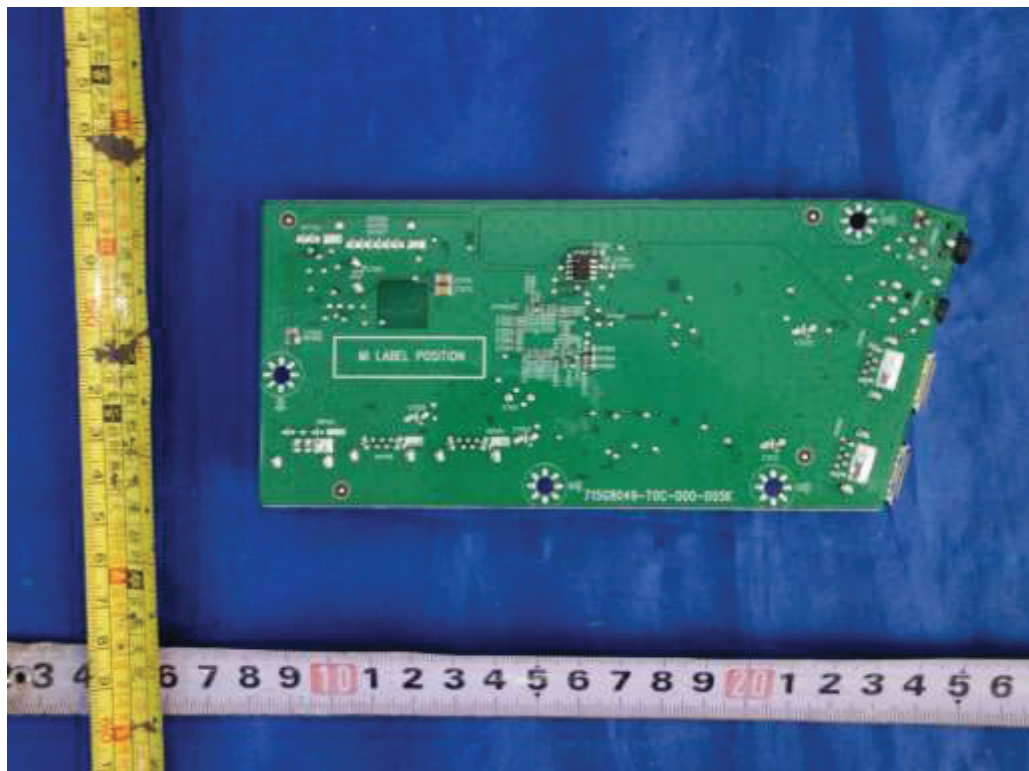

Figure 16. USB board 715G8049