



FCC DOC TEST REPORT

Declaration of Conformity

According to

**47 CFR, Part 2, Part 15, CISPR PUB. 22,
Canada ICES-003 Issue 5**

Applicant : TPV Electronics (Fujian) Co., Ltd.
Address : Shangzheng, Yuanhong Road, Fuqing City,
Fujian Province, P.R.China
Equipment : LCD Monitor
Model No. : 270LM00014, Q2778****

- The test result refers exclusively to the test presented test model / sample.
- Without written approval of **CerpPASS Technology Corp.** the test report shall not be reproduced except in full.

Laboratory Accreditation





Contents

1. Summary of Test Procedure and Test Result.....	5
2. Test Configuration of Equipment under Test.....	6
2.1. Feature of Equipment under Test.....	6
2.2. Test Manner	6
2.3. Description of Test System.....	7
2.4. General Information of Test.....	8
2.5. Measurement Uncertainty	8
3. Test of Conducted Emission.....	9
3.1. Test Limit	9
3.2. Test Procedures	9
3.3. Typical test Setup.....	10
3.4. Measurement Equipment.....	10
3.5. Test Result and Data.....	11
3.6. Test Photographs	13
4. Test of Radiated Emission	14
4.1. Test Limit	14
4.2. Test Procedures	14
4.3. Typical test Setup.....	15
4.4. Measurement Equipment.....	15
4.5. Test Result and Data (30MHz ~ 1GHz).....	16
4.6. Test Result and Data (1GHz ~ 18GHz).....	20
4.7. Test Photographs (30MHz~1GHz).....	22
4.8. Test Photographs (1GHz~18GHz)	23
5. Photographs of EUT	24



History of this test report

ORIGINAL.

Additional attachment as following record:

Attachment No.	Issue Date	Description



FCC DOC TEST REPORT

Declaration of Conformity

According to

**47 CFR, Part 2, Part 15, CISPR PUB. 22,
Canada ICES-003 Issue 5**

Applicant : TPV Electronics (Fujian) Co., Ltd.
Address : Shangzheng, Yuanhong Road, Fuqing City,
Fujian Province, P.R.China
Equipment : LCD Monitor
Model No. : 270LM00014, Q2778****

I HEREBY CERTIFY THAT :

The measurements shown in this test report were made in accordance with the procedures given in **ANSI C63.4 – 2009** and the energy emitted by this equipment was **passed CISPR PUB. 22 FCC Part 15, Canada ICES-003 Issue 5** in both radiated and conducted emission class B limits.

The sample was received on Sep. 29, 2014 and the testing was carried out on Oct. 01, 2014 at CerpPASS Technology Corp.

Signature

Hill Chen
EMC/RF B.U. Assistant Manager



1. Summary of Test Procedure and Test Result

Test Item	Normative References	Test Result	Remarks
Conducted Emission (Mains Ports)	FCC 47 CFR Part 15 Subpart B ANSI C63.4-2009 ICES-003: 2004 Issue 5	PASS	Meets Class B Limit Minimum passing margin(AVG) is -9.38 dB at 14.8500 MHz
Radiated Emission	FCC 47 CFR Part 15 Subpart B ANSI C63.4-2009 ICES-003: 2004 Issue 5	PASS	Meets Class B Limit Minimum passing margin(QP) is -4.30 dB at 157.6000 MHz



2. Test Configuration of Equipment under Test

2.1. Feature of Equipment under Test

LCD Monitor	Model No :	270LM00014, Q2778****
Power Cable	Non-Shielding, 1.5m & 1.8m	
Please refer to the user's manual.		

2.2. Test Manner

- a. During testing, the interface cables and equipment positions were varied according to ANSI C63.4.
- b. The complete test system included PC, Keyboard, Mouse, Printer, iPod, Earphone, DVD player and EUT for EMI test.
- c. An executive program, "Burnin.exe" under WIN 7, which generates a complete line of continuously repeating "H" pattern was used as the test software.
The program was executed as follows:
 1. Turn on the power of all equipment.
 2. The PC reads the test program from the hard disk drive and runs it.
 3. The PC sends "H" messages to the EUT, and the EUT displays "H" patterns on the screen.
 4. The PC sends "H" messages to the internal Hard Disk, and the Hard Disk reads and writes the message.
 5. The PC sends "H" messages to the printer, then the printer prints them on the paper.
 6. Repeat the steps from 2 to 5.
- d. The test modes of EMI test as follow:
 - Test Mode 1. VGA: 2560 x 1440@60Hz
 - Test Mode 2. VGA: 1280 x 1024@75Hz
 - Test Mode 3. VGA: 640 x 480@60Hz
 - Test Mode 4. DVI: 2560 x 1440@60Hz
 - Test Mode 5. DVI: 1280 x 1024@75Hz
 - Test Mode 6. DVI: 640 x 480@60Hz
 - Test Mode 7. HDMI: 2560 x 1440@60Hz
 - Test Mode 8. HDMI: 1280 x 1024@75Hz
 - Test Mode 9. HDMI: 640 x 480@60Hz
 - Test Mode 10. Display: 2560 x 1440@60Hz
 - Test Mode 11. Display: 1280 x 1024@75Hz
 - Test Mode 12. Display: 640 x 480@60Hz
 - Test Mode 13. DVD mode

For conduction test, "Test Mode 4" generated the worst test result, it was reported as final data.
For radiation test, "Test Mode 1" generated the worst test result, it was reported as final data.



2.3. Description of Test System

Device	Manufacturer	Model No.	Description
PC	DELL	XPS8500	Power Cable, Non-Shielded, 1.8m
Keyboard	DELL	SK-8175	Data Cable, USB Shielding 1.85m
Mouse	DELL	MOC5UO	Data Cable, USB Shielding 1.85m
iPod	APPLE	A1320	Data Cable, USB Shielding 1m
Earphone	INTOPIC	JAZZ-269	Data Cable, Audio Unshielding 1.35m
DVD player	SONY	DVP-NS718HP	Power Cable, Unshielding, 1.8m
Printer	HP	D2660	Power Cable, Non-Shielded 1.8m Data Cable, USB Shielding 1.6m

Use Cable:

Cable	Quantity	Description
VGA cable	1	Shielding, 1.8m & 1.5m with two ferrite cores bonded
DVI cable	1	Shielding, 1.8m & 1.5m with two ferrite cores bonded
HDMI	1	Shielding, 1.8m & 1.5m
Display	1	Shielding, 1.8m & 1.5m
Audio	1	Shielding, 1.8m & 1.5m

**2.4. General Information of Test**

Test Site :	Cerpass Technology Corporation Test Laboratory No.10, Lane 2, Lianfu Street, Luzhu Township, Taoyuan County 33848, Taiwan(R.O.C.)
Test Site:	No.68-1, Shihbachongsi, Shihding Township, New Taipei City 223, Taiwan, R.O.C.
FCC Registration Number :	<input type="checkbox"/> TW1079, <input checked="" type="checkbox"/> TW1061, <input checked="" type="checkbox"/> 390316, <input type="checkbox"/> 228391, <input type="checkbox"/> 641184
IC Registration Number :	<input checked="" type="checkbox"/> 4934B-1, <input type="checkbox"/> 4934E-1, <input type="checkbox"/> 4934E-2
VCCI Registration Number :	<input type="checkbox"/> T-2205 for Telecommunication Test <input checked="" type="checkbox"/> C-4463 for Conducted emission test <input checked="" type="checkbox"/> R-3428 for Radiated emission test <input checked="" type="checkbox"/> G-812 for radiated disturbance above 1GHz <input type="checkbox"/> G-813 for radiated disturbance above 1GHz
Frequency Range Investigated :	Conducted Emission Test: from 150 kHz to 30 MHz Radiated Emission Test: from 30 MHz to 18,000 MHz
Test Distance :	The test distance of radiated emission below 1GHz from antenna to EUT is 10 M. The test distance of radiated emission above 1GHz from antenna to EUT is 3 M.

2.5. Measurement Uncertainty

Measurement Item	Measurement Frequency	Polarization	Uncertainty
Conducted Emission	9 kHz ~ 30 MHz	LINE / NEUTRAL	3.25 dB
Radiated Emission	30 MHz ~ 1,000 MHz	Vertical / Horizontal	3.93 dB
	1,000 MHz ~ 15,000 MHz	Vertical / Horizontal	5.18 dB

The measurement uncertainty will be considered, when test result margin to the limit.



3. Test of Conducted Emission

3.1. Test Limit

Conducted Emissions were measured from 150 kHz to 30 MHz with a bandwidth of 9 KHz on the 120 VAC power and return leads of the EUT according to the methods defined in ANSI C63.4-2009 Section 3.1. The EUT was placed on a nonmetallic stand in a shielded room 0.8 meters above the ground plane as shown in section 2.2. The interface cables and equipment positioning were varied within limits of reasonable applications to determine the position produced maximum conducted emissions.

Conducted Emission Limits:

Frequency (MHz)	Quasi Peak (dB μ V)	Average (dB μ V)
0.15 – 0.5	66-56*	56-46*
0.5 – 5.0	56	46
5.0 – 30.0	60	50

3.2. Test Procedures

- a. The EUT was placed 0.4 meter from the conducting wall of the shielding room was kept at least 80 centimeters from any other grounded conducting surface.
- b. Connect EUT to the power mains through a line impedance stabilization network (LISN).
- c. All the support units are connecting to the other LISN.
- d. The LISN provides 50 ohm coupling impedance for the measuring instrument.
- e. The FCC states that a 50 ohm, 50 micro-Henry LISN should be used.
- f. Both sides of AC line were checked for maximum conducted interference.
- g. The frequency range from 150 kHz to 30 MHz was searched.
- h. Set the test-receiver system to Peak Detect Function and Specified Bandwidth with Maximum Hold Mode.

3.3. Typical test Setup

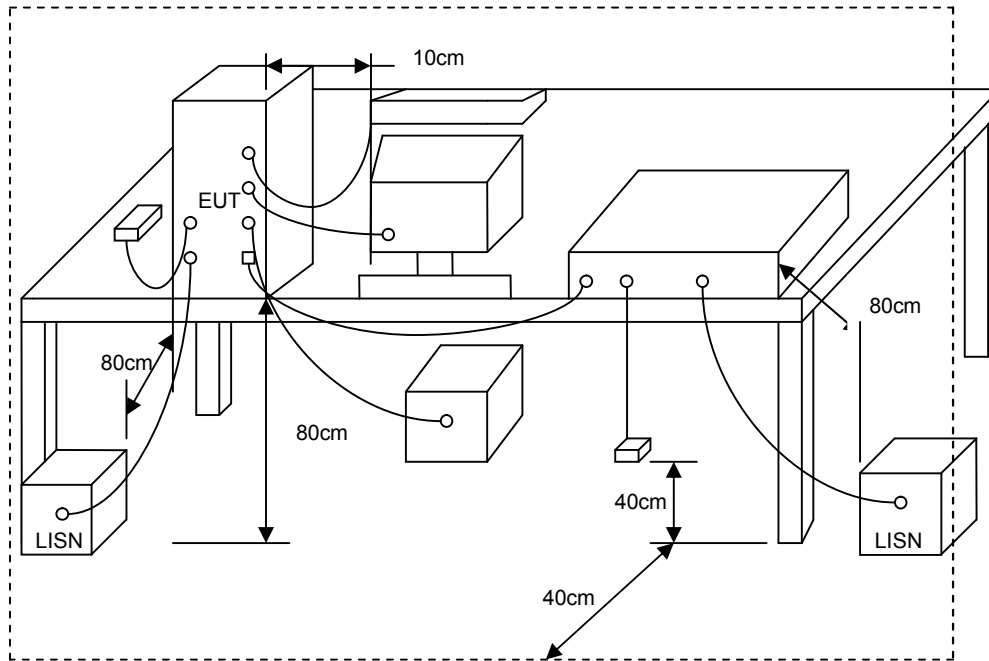

3.4. Measurement Equipment

Instrument	Manufacturer	Model No.	Serial No.	Calibration Date	Valid Date
EMI Receiver	R&S	ESCI	101423	2014/06/05	2015/06/04
LISN	Schwarzbeck	NSLK 8127	8127-740	2014/08/14	2015/08/13
LISN	Schwarzbeck	NSLK 8127	8127-516	2014/03/10	2015/03/09
Pulse Limiter	R&S	ESH3-Z2	101933	2014/08/12	2015/08/11
Software	Farad	Ez-EMC	ver.ct3a1	N/A	N/A



3.5. Test Result and Data

Power	: AC 120V	Pol/Phase	: LINE
Test Mode 4	: DVI: 2560 x 1440@60Hz	Temperature	: 24 °C
Test Date	: Sep. 29, 2014	Humidity	: 52 %
Model No.	: 270LM00014	Atmospheric Pressure	: 1008 hPa

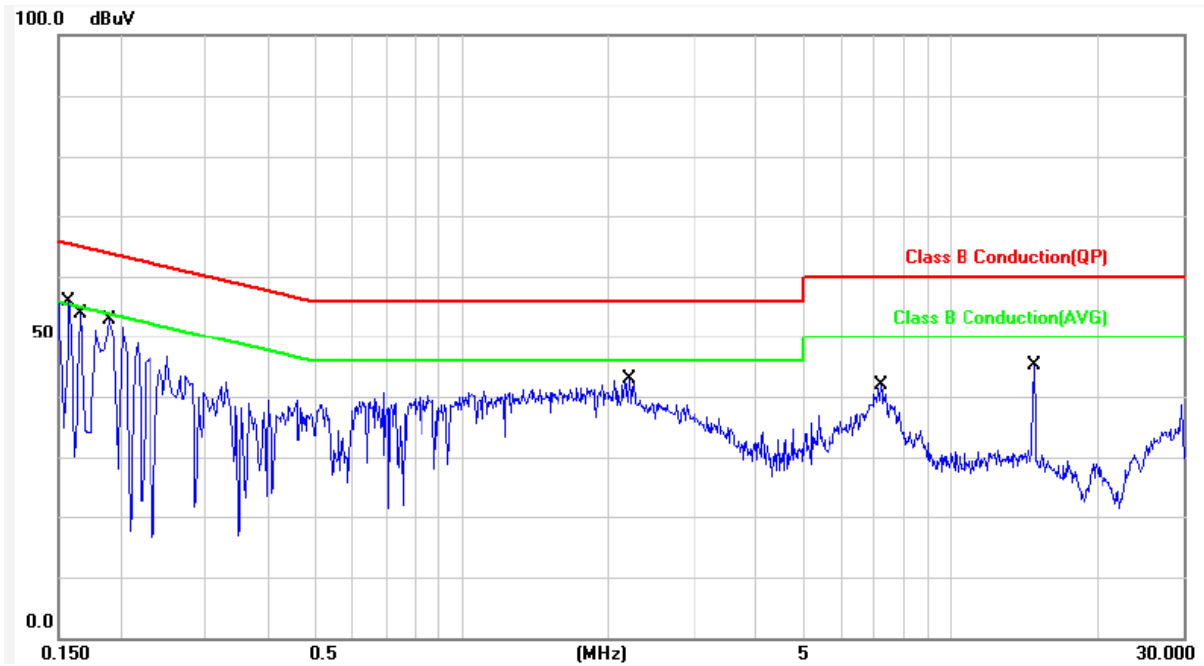

No.	Frequency (MHz)	Factor (dB)	Reading (dBuV)	Level (dBuV)	Limit (dBuV)	Margin (dB)	Detector	P/F
1	0.1580	9.92	37.63	47.55	65.56	-18.01	QP	P
2	0.1580	9.92	12.52	22.44	55.56	-33.12	AVG	P
3	0.1660	9.92	36.32	46.24	65.15	-18.91	QP	P
4	0.1660	9.92	11.13	21.05	55.15	-34.10	AVG	P
5	0.1900	9.92	38.08	48.00	64.03	-16.03	QP	P
6	0.1900	9.92	23.32	33.24	54.03	-20.79	AVG	P
7	2.2100	10.03	27.24	37.27	56.00	-18.73	QP	P
8	2.2100	10.03	17.01	27.04	46.00	-18.96	AVG	P
9	7.2260	10.18	26.81	36.99	60.00	-23.01	QP	P
10	7.2260	10.18	17.29	27.47	50.00	-22.53	AVG	P
11	14.8500	10.38	33.05	43.43	60.00	-16.57	QP	P
12	14.8500	10.38	29.89	40.27	50.00	-9.73	AVG	P

Note: Level = Reading + Factor

Margin = Level – Limit

Factor = (LISN or ISN or PLC or current probe) Factor + Cable Loss



Power	: AC 120V	Pol/Phase	: NEUTRAL
Test Mode 4	: DVI: 2560 x 1440@60Hz	Temperature	: 24 °C
Test Date	: Sep. 29, 2014	Humidity	: 52 %
Model No.	: 270LM00014	Atmospheric Pressure	: 1008 hPa

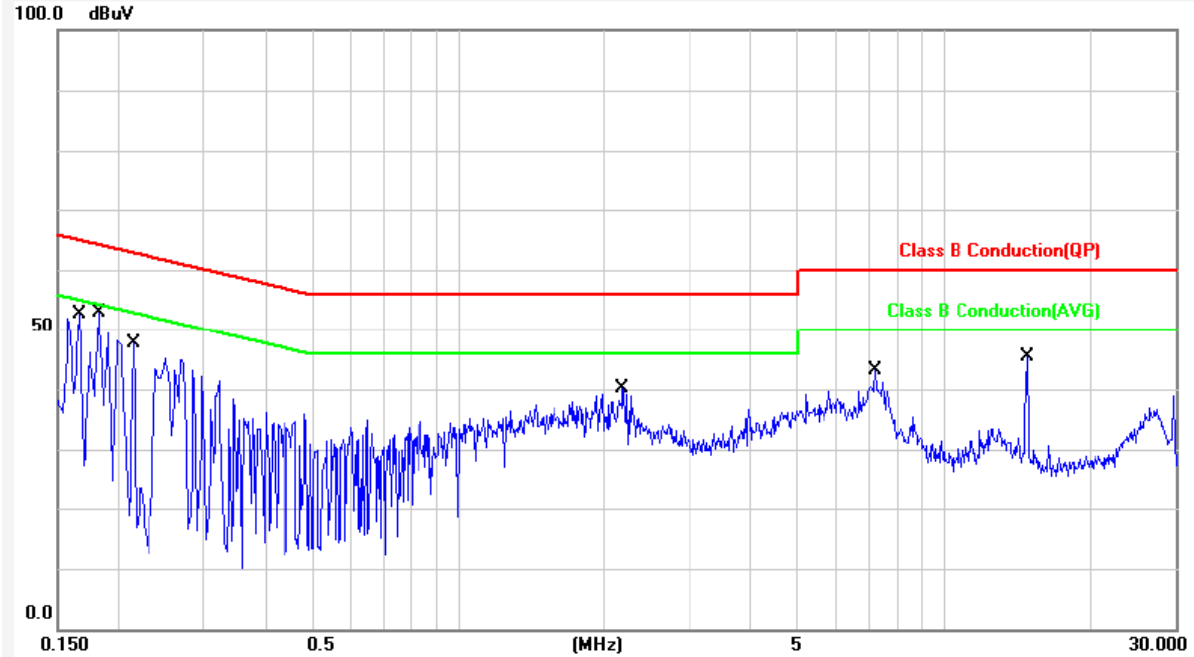

No.	Frequency (MHz)	Factor (dB)	Reading (dBuV)	Level (dBuV)	Limit (dBuV)	Margin (dB)	Detector	P/F
1	0.1660	9.92	36.41	46.33	65.15	-18.82	QP	P
2	0.1660	9.92	10.94	20.86	55.15	-34.29	AVG	P
3	0.1819	9.91	38.97	48.88	64.39	-15.51	QP	P
4	0.1819	9.91	24.71	34.62	54.39	-19.77	AVG	P
5	0.2140	9.91	31.17	41.08	63.04	-21.96	QP	P
6	0.2140	9.91	7.06	16.97	53.04	-36.07	AVG	P
7	2.1860	10.03	24.52	34.55	56.00	-21.45	QP	P
8	2.1860	10.03	11.46	21.49	46.00	-24.51	AVG	P
9	7.2220	10.18	25.74	35.92	60.00	-24.08	QP	P
10	7.2220	10.18	17.10	27.28	50.00	-22.72	AVG	P
11	14.8500	10.36	33.48	43.84	60.00	-16.16	QP	P
12	14.8500	10.36	30.26	40.62	50.00	-9.38	AVG	P

Note: Level = Reading + Factor
Margin = Level – Limit
Factor = (LISN or ISN or PLC or current probe) Factor + Cable Loss

Test engineer: Charlie



3.6. Test Photographs

Front View



Rear View





4. Test of Radiated Emission

4.1. Test Limit

Radiated emissions from 30 MHz to 18,000 MHz were measured with a bandwidth of 120 kHz according to the methods defines in ANSI C63.4-2009. The EUT was placed on a nonmetallic stand in the open-field site, 0.8 meter above the ground plane, as shown in section 3.2. The interface cables and equipment positions were varied within limits of reasonable applications to determine the positions producing maximum radiated emissions.

For unintentional device, according to § 15.109(a), except for Class A digital devices, the field strength of radiated emissions from unintentional radiators at a distance of 3 meters shall not exceed the following values:

Frequency (MHz)	Distance Meters	Radiated ($\mu\text{V} / \text{M}$)	Radiated ($\text{dB } \mu\text{V} / \text{M}$)
30-88	3	100	40.0
88-216	3	150	43.5
216-960	3	200	46.0
Above 960	3	500	54.0

For unintentional device, according to CISPR PUB.22, for Class B digital devices, the general requirement of field strength of radiated emissions from intentional radiators at a distance of 10 meters shall not exceed the below table.

Frequency (MHz)	Distance Meters	Radiated ($\text{dB } \mu\text{V} / \text{M}$)
30-230	10	30
230-1000	10	37

4.2. Test Procedures

- The EUT was placed on a Rota table top 0.8 meter above ground.
- The EUT was set 3/10 meters from the interference receiving antenna which was mounted on the top of a variable height antenna tower.
- The table was rotated 360 degrees to determine the position of the highest radiation.
- The antenna is a half wave dipole and its height is varied between one meter and four meters above ground to find the maximum value of the field strength both horizontal polarization and vertical polarization of the antenna are set to make the measurement.
- For each suspected emission the EUT was arranged to its worst case and then tune the antenna tower (from 1 M to 4 M) and turn table (from 0 degree to 360 degrees) to find the maximum reading.
- Set the test-receiver system to Peak Detect Function and specified bandwidth with Maximum Hold Mode.
- If the emission level of the EUT in peak mode was 6 dB lower than the limit specified, then testing will be stopped and peak values of EUT will be reported, otherwise, the emissions which do not have 6 dB margin will be repeated one by one using the quasi-peak method and reported.

4.3. Typical test Setup

Below 1GHz Test Setup

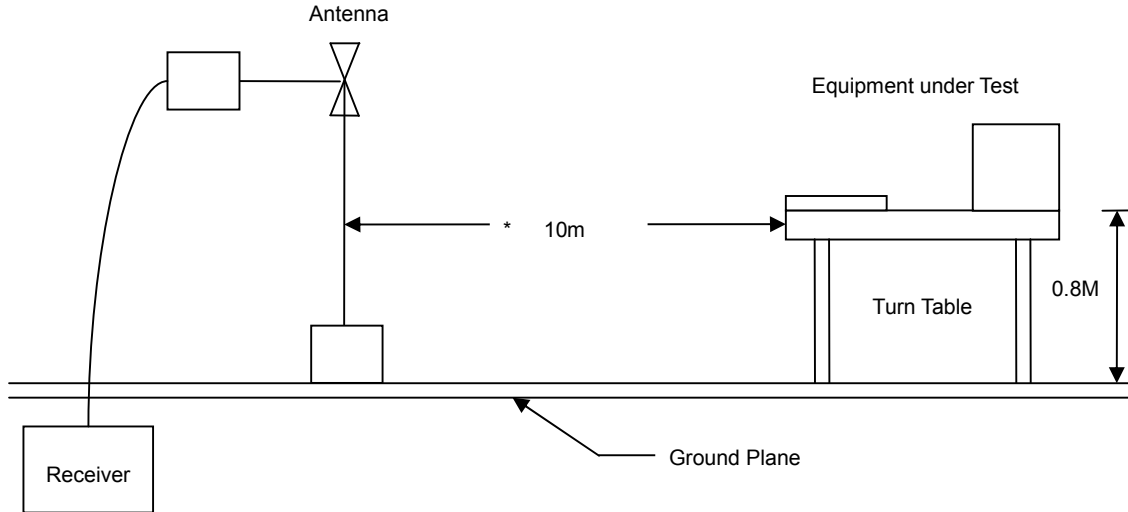

Above 1GHz Test Setup

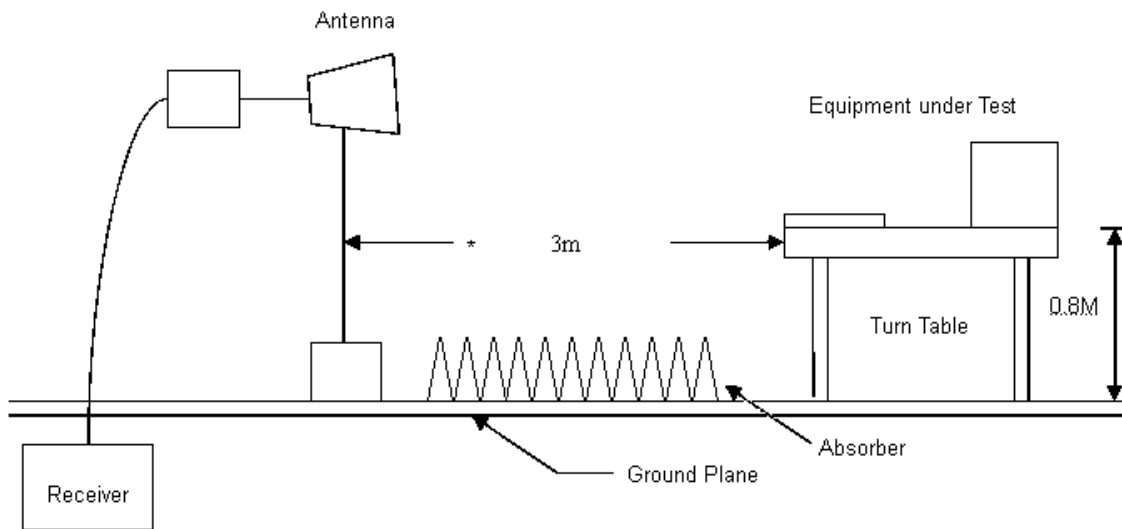

4.4. Measurement Equipment

Instrument	Manufacturer	Model No.	Serial No.	Calibration Date	Valid Date
Bilog Antenna	Sciences Corporation	JB1	A080713	2014/08/22	2015/08/21
Amplifier	AGILENT	8447D	2944A10531	2014/08/12	2015/08/11
EMI Receiver	R&S	ESCI	101200	2014/08/13	2015/08/12
Software	Farad	Ez-EMC	ver.ct3a1	N/A	N/A
Spectrum Analyzer	R&S	FSP40	100219	2014/09/03	2015/09/02
Horn Antenna	EMCO	3115	31601	2014/07/09	2015/07/08
Preamplifier	AGILENT	8449B	3008A01954	2014/03/28	2015/03/27



4.5. Test Result and Data (30MHz ~ 1GHz)

Power	: AC 120V	Pol/Phase	: VERTICAL
Test Mode 1	: VGA: 2560 x 1440@60Hz	Temperature	: 25°C
Test Date	: Oct. 01, 2014	Humidity	: 69%
Model No.	: 270LM00014	Atmospheric Pressure	: 998 hPa

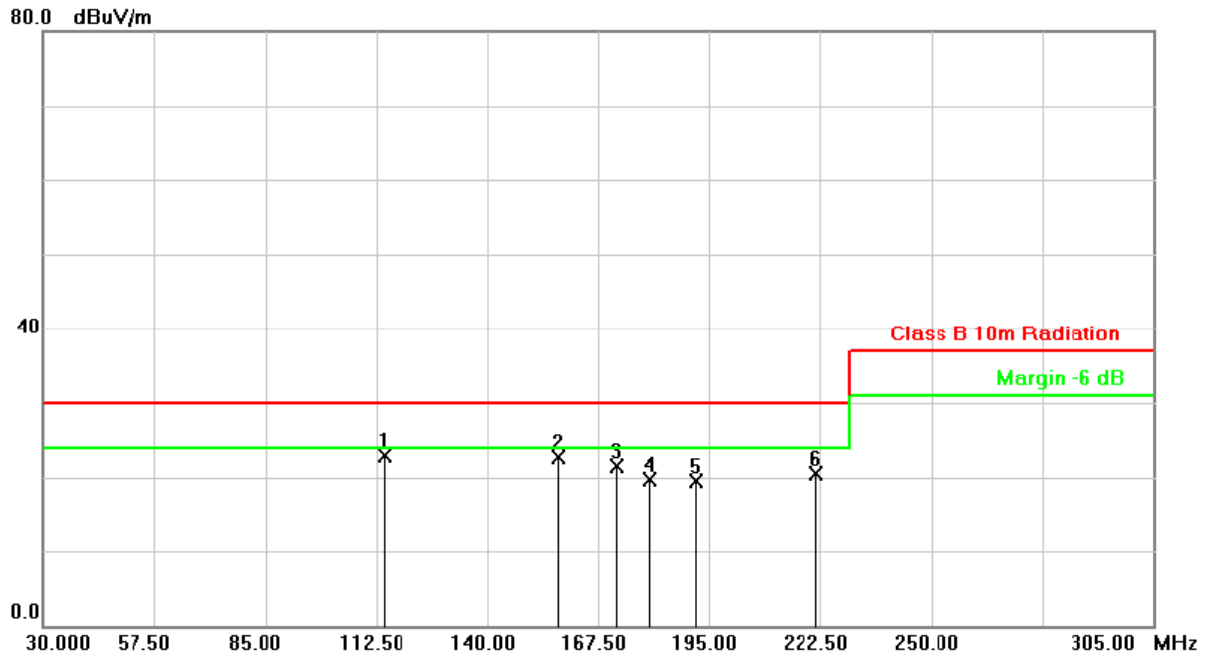

No.	Frequency (MHz)	Factor (dB/m)	Reading (dBuV)	Level (dBuV/m)	Limit (dBuV/m)	Margin (dB)	Detector	Height (cm)	Azimuth (°)	P/F
1	114.4250	-13.48	36.39	22.91	30.00	-7.09	peak	400	0	P
2	157.6000	-14.00	36.73	22.73	30.00	-7.27	peak	400	0	P
3	171.9000	-14.43	35.86	21.43	30.00	-8.57	peak	400	0	P
4	180.1500	-14.92	34.68	19.76	30.00	-10.24	peak	400	0	P
5	191.9750	-14.31	33.77	19.46	30.00	-10.54	peak	400	0	P
6	221.4000	-14.98	35.45	20.47	30.00	-9.53	peak	400	0	P

Note: Level = Reading + Factor
 Margin = Level – Limit
 Factor = Antenna factor + Cable loss - Amplifier factor



Power	: AC 120V	Pol/Phase	: VERTICAL
Test Mode 1	: VGA: 2560 x 1440@60Hz	Temperature	: 25°C
Test Date	: Oct. 01, 2014	Humidity	: 69%
Model No.	: 270LM00014	Atmospheric Pressure	: 998 hPa

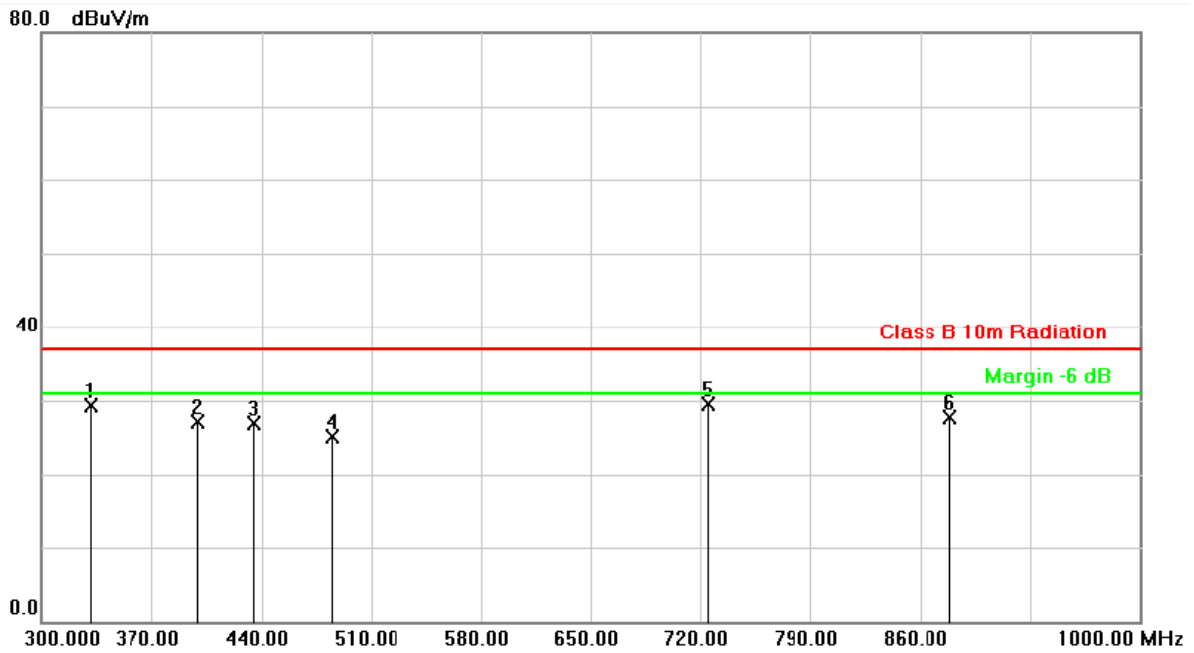

No.	Frequency (MHz)	Factor (dB/m)	Reading (dBuV)	Level (dBuV/m)	Limit (dBuV/m)	Margin (dB)	Detector	Height (cm)	Azimuth (°)	P/F
1	330.8000	-11.42	40.77	29.35	37.00	-7.65	peak	100	0	P
2	399.4000	-10.16	37.28	27.12	37.00	-9.88	peak	100	0	P
3	435.1000	-9.06	35.95	26.89	37.00	-10.11	peak	100	0	P
4	485.5000	-8.09	33.17	25.08	37.00	-11.92	peak	100	0	P
5	724.9000	-4.30	33.76	29.46	37.00	-7.54	peak	100	0	P
6	878.9000	-2.08	29.74	27.66	37.00	-9.34	peak	100	0	P

Note: Level = Reading + Factor
Margin = Level – Limit
Factor = Antenna factor + Cable loss - Amplifier factor



Power	: AC 120V	Pol/Phase	: HORIZONTAL
Test Mode 1	: VGA: 2560 x 1440@60Hz	Temperature	: 25°C
Test Date	: Oct. 01, 2014	Humidity	: 69%
Model No.	: 270LM00014	Atmospheric Pressure	: 998 hPa

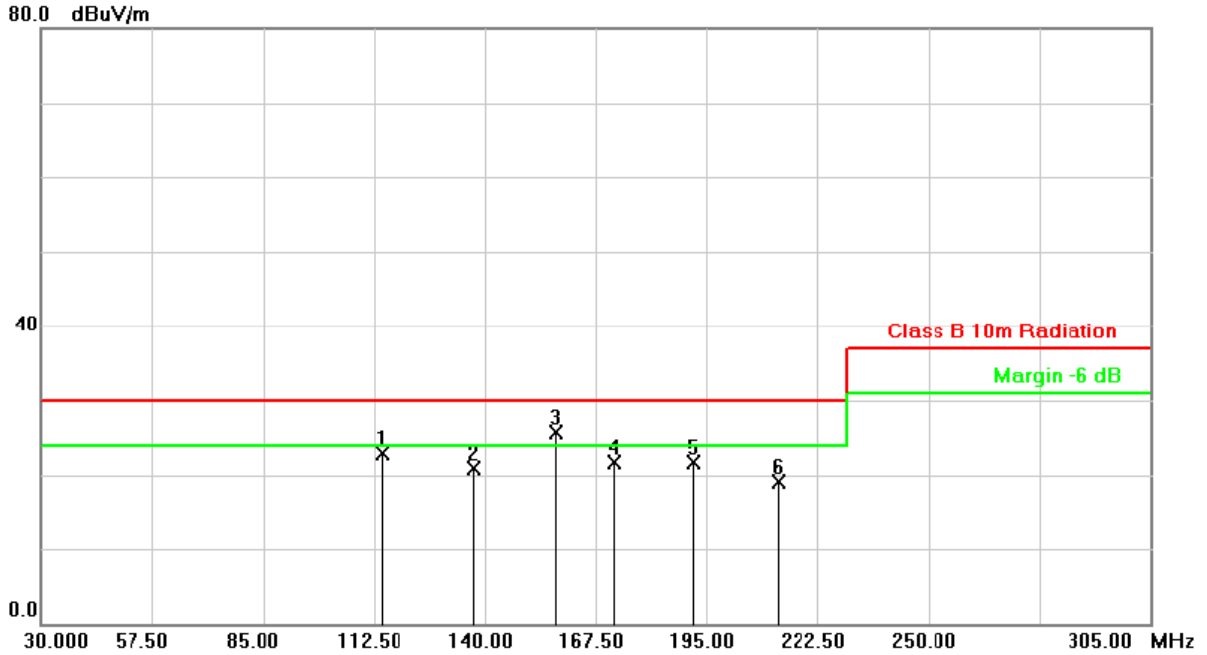

No.	Frequency (MHz)	Factor (dB/m)	Reading (dBuV)	Level (dBuV/m)	Limit (dBuV/m)	Margin (dB)	Detector	Height (cm)	Azimuth (°)	P/F
1	114.4250	-13.48	36.41	22.93	30.00	-7.07	peak	400	0	P
2	137.2500	-13.11	34.11	21.00	30.00	-9.00	peak	400	0	P
3	157.6000	-14.00	39.70	25.70	30.00	-4.30	QP	374	133	P
4	171.9000	-14.43	36.18	21.75	30.00	-8.25	peak	400	0	P
5	191.9750	-14.31	35.95	21.64	30.00	-8.36	peak	400	0	P
6	212.6000	-15.26	34.27	19.01	30.00	-10.99	peak	400	0	P

Note: Level = Reading + Factor
Margin = Level – Limit
Factor = Antenna factor + Cable loss - Amplifier factor



Power	: AC 120V	Pol/Phase	: HORIZONTAL
Test Mode 1	: VGA: 2560 x 1440@60Hz	Temperature	: 25°C
Test Date	: Oct. 01, 2014	Humidity	: 69%
Model No.	: 270LM00014	Atmospheric Pressure	: 998 hPa

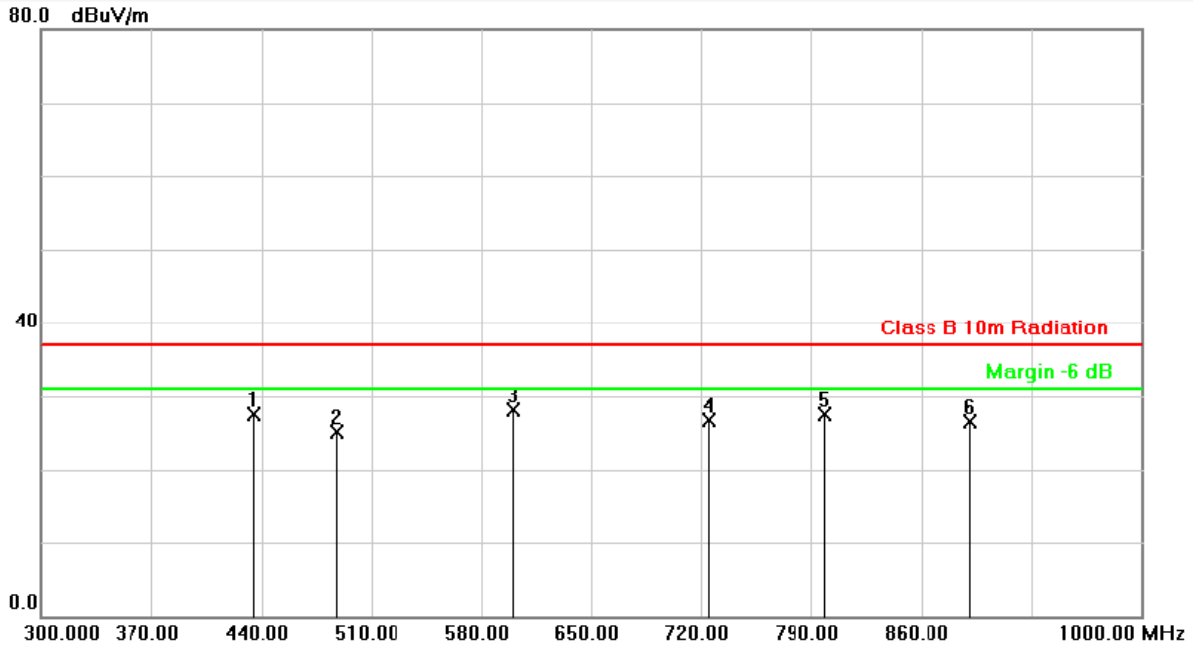

No.	Frequency (MHz)	Factor (dB/m)	Reading (dBuV)	Level (dBuV/m)	Limit (dBuV/m)	Margin (dB)	Detector	Height (cm)	Azimuth (°)	P/F
1	435.1000	-9.06	36.51	27.45	37.00	-9.55	peak	100	0	P
2	487.6000	-8.07	33.08	25.01	37.00	-11.99	peak	100	0	P
3	600.3000	-6.73	34.88	28.15	37.00	-8.85	peak	100	0	P
4	724.9000	-4.30	30.96	26.66	37.00	-10.34	peak	100	0	P
5	798.4000	-3.12	30.54	27.42	37.00	-9.58	peak	100	0	P
6	891.5000	-1.87	28.37	26.50	37.00	-10.50	peak	100	0	P

Note: Level = Reading + Factor
 Margin = Level – Limit
 Factor = Antenna factor + Cable loss - Amplifier factor

Test engineer: Ken



4.6. Test Result and Data (1GHz ~ 18GHz)

Power	: AC 120V	Pol/Phase	: VERTICAL
Test Mode 1	: VGA: 2560 x 1440@60Hz	Temperature	: 25°C
Test Date	: Sep. 30, 2014	Humidity	: 52%
Model No.	: 270LM00014	Atmospheric Pressure	: 1010 hPa

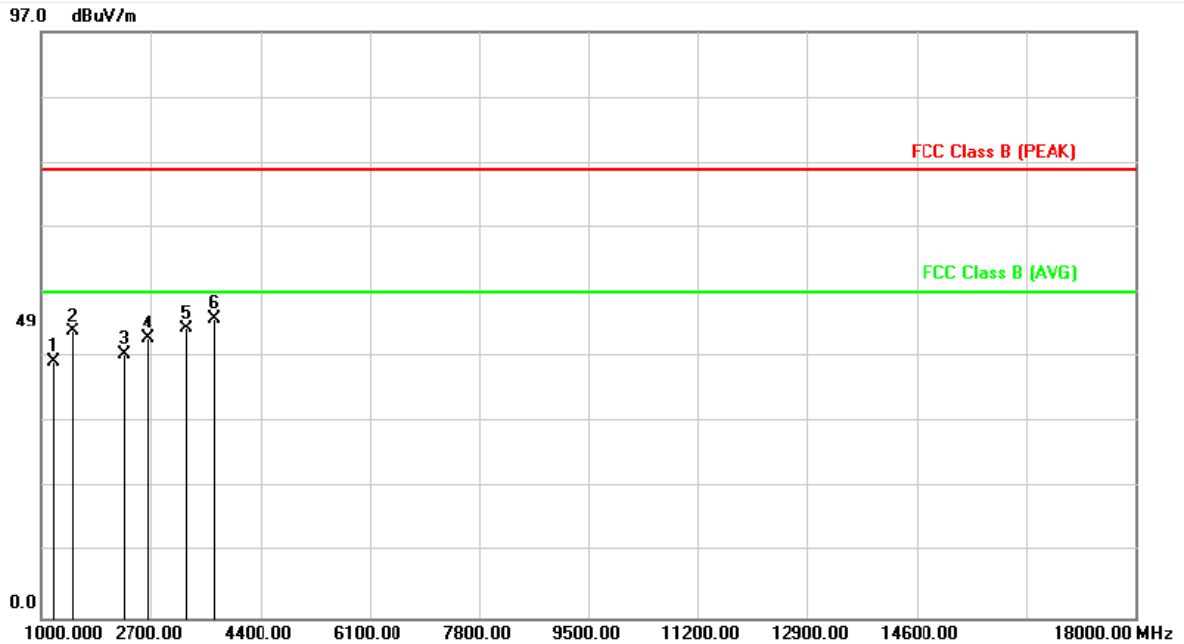

No.	Frequency (MHz)	Factor (dB/m)	Reading (dBuV)	Level (dBuV/m)	Limit (dBuV/m)	Margin (dB)	Detector	Height (cm)	Azimuth (°)	P/F
1	1187.000	-8.07	50.45	42.38	74.00	-31.62	peak	100	0	P
2	1493.000	-6.01	53.36	47.35	74.00	-26.65	peak	100	0	P
3	2275.000	-1.62	45.07	43.45	74.00	-30.55	peak	100	0	P
4	2666.000	0.06	46.06	46.12	74.00	-27.88	peak	100	0	P
5	3261.000	2.64	45.37	48.01	74.00	-25.99	peak	100	0	P
6	3686.000	4.37	45.15	49.52	74.00	-24.48	peak	100	0	P

Note: Level = Reading + Factor
 Margin = Level – Limit
 Factor = Antenna factor + Cable loss - Amplifier factor



Power	: AC 120V	Pol/Phase	: HORIZONTAL
Test Mode 1	: VGA: 2560 x 1440@60Hz	Temperature	: 25°C
Test Date	: Sep. 30, 2014	Humidity	: 52%
Model No.	: 270LM00014	Atmospheric Pressure	: 1010 hPa

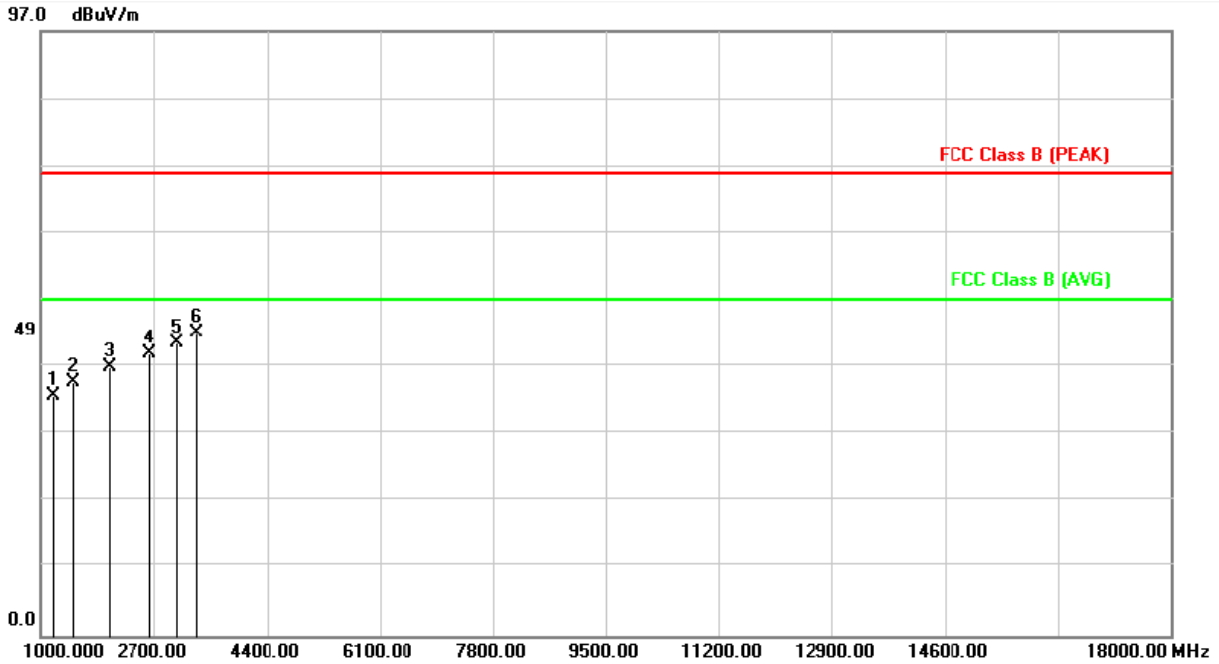

No.	Frequency (MHz)	Factor (dB/m)	Reading (dBuV)	Level (dBuV/m)	Limit (dBuV/m)	Margin (dB)	Detector	Height (cm)	Azimuth (°)	P/F
1	1187.000	-8.07	46.58	38.51	74.00	-35.49	peak	200	0	P
2	1476.000	-6.14	46.80	40.66	74.00	-33.34	peak	200	0	P
3	2020.000	-2.58	45.67	43.09	74.00	-30.91	peak	200	0	P
4	2632.000	-0.10	45.30	45.20	74.00	-28.80	peak	200	0	P
5	3040.000	1.85	45.07	46.92	74.00	-27.08	peak	200	0	P
6	3346.000	2.95	45.79	48.74	74.00	-25.26	peak	200	0	P

Note: Level = Reading + Factor
 Margin = Level – Limit
 Factor = Antenna factor + Cable loss - Amplifier factor

Test engineer: *Carp*



4.7. Test Photographs (30MHz~1GHz)

Front View



Rear View





4.8. Test Photographs (1GHz~18GHz)

Front View



Rear View

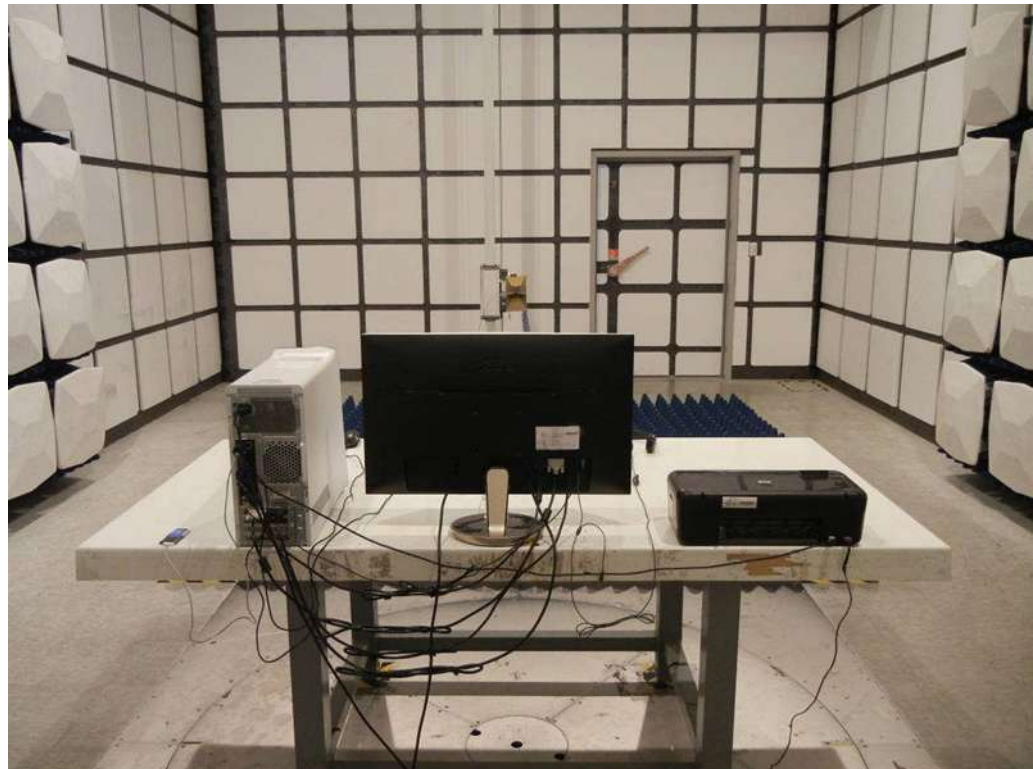



5. Photographs of EUT

