



# EMC TEST REPORT

Authorized under Declaration of Conformity

According to

EN 55032: 2012+AC 2013 (Class B)	EN 55024 : 2010
EN 61000-3-2 : 2014	IEC 61000-4-2 : 2008
EN 61000-3-3 : 2013	IEC 61000-4-3 : 2006+A1:2007+A2:2010
CISPR 32 : 2015	IEC 61000-4-4 : 2012
AS/NZS CISPR 32 : 2013	IEC 61000-4-5 : 2014
	IEC 61000-4-6 : 2013
	IEC 61000-4-8 : 2009
	IEC 61000-4-11 : 2004

Applicant	: TPV Electronics (Fujian) Co., Ltd.
Address	: Rongqiao Economic and Technological Development Zone, Fuqing City, Fujian Province, P.R. China
Equipment	: LCD Monitor *220*****, 215LM00071
Model No.	: (The "*" could be any alphanumeric character including blank for marketing differentiation.)

## I HEREBY CERTIFY THAT :

The sample was received on Apr 26, 2017 and the testing was carried out on May 08, 2017 at CerpPASS Technology Corp. The test result refers exclusively to the test presented test model / sample. Without written approval of CerpPASS Technology Corp., the test report shall not be reproduced except in full.



# EMC TEST REPORT

Issued by:

**CerpPASS Technology (Suzhou) Co.,Ltd**

**No.66,Tangzhuang Road, Suzhou Industrial Park, Jiangsu 215006, China**

**Tel:86-512-6917-5888**

**Fax:86-512-6917-5666**

The test record, data evaluation & Equipment Under Test configurations represented herein are true and accurate accounts of the measurements of the samples EMC characteristics under the conditions specified in this report.

The above equipment was tested by CerpPASS Technology Corp. for compliance with the requirements of technical standards specified above under the EMC Directive. The results of testing in this report apply only to the product/system, which was tested. Other similar equipment will not necessarily produce the same results due to production tolerance and measurement uncertainties

Approved by:

Miro Chueh  
EMC/RF B.U. Manager

Laboratory Accreditation:

CerpPASS Technology Corporation Test Laboratory

<b>NVLAP LAB Code:</b>	<b>200954-0</b>
<b>TAF LAB Code:</b>	<b>1439</b>

CerpPASS Technology(SuZhou) Co., Ltd.

<b>NVLAP LAB Code:</b>	<b>200814-0</b>
<b>CNAS LAB Code:</b>	<b>L5515</b>



## Contents

<b>1. Summary of Test Procedure and Test Results</b> .....	<b>6</b>
<b>2. Immunity Testing Performance Criteria Definition</b> .....	<b>7</b>
<b>3. Test Configuration of Equipment under Test</b> .....	<b>8</b>
3.1. Feature of Equipment under Test.....	8
3.2. Test Manner .....	9
3.3. Description of Support Unit .....	10
3.4. General Information of Test.....	11
3.5. Measurement Uncertainty .....	12
<b>4. Test of Conducted Emission</b> .....	<b>14</b>
4.1. Test Limit .....	14
4.2. Test Procedures .....	17
4.3. Typical Test Setup .....	17
4.4. Measurement Equipment.....	18
4.5. Test Result and Data.....	19
4.6. Test Photographs .....	28
<b>5. Test of Radiated Emission</b> .....	<b>29</b>
5.1. Test Limit.....	29
5.2. Test Procedures .....	32
5.3. Typical Test Setup .....	32
5.4. Measurement Equipment.....	33
5.5. Test Result and Data (30MHz ~ 1GHz).....	34
5.6. Test Result and Data (1GHz~6GHz).....	42
5.7. Test Photographs (30MHz~1GHz) .....	50
5.8. Test Photographs (1GHz~6GHz) .....	51
<b>6. Harmonics Test</b> .....	<b>52</b>
6.1. Limits of Harmonics Current Measurement .....	52
6.2. Measurement Equipment.....	53
6.3. Test Result and Data.....	54
6.4. Test Photographs .....	56
<b>7. Voltage Fluctuations Test</b> .....	<b>57</b>
7.1. Test Procedure .....	57
7.2. Measurement Equipment.....	57
7.3. Test Result and Data.....	58
7.4. Test Photographs .....	60
<b>8. Electrostatic Discharge Immunity Test</b> .....	<b>61</b>
8.1. Test Procedure .....	61
8.2. Test Setup for Tests Performed in Laboratory.....	62
8.3. Test Severity Levels .....	63
8.4. Measurement Equipment.....	63
8.5. Test Result and Data.....	64
8.6. Test Photographs .....	65



- 9. Radio Frequency electromagnetic field immunity test ..... 66**
  - 9.1. Test Procedure ..... 66
  - 9.2. Test Severity Levels ..... 66
  - 9.3. TEST SETUP ..... 67
  - 9.4. Measurement Equipment..... 68
  - 9.5. Test Result and Data ..... 69
  - 9.6. Test Photographs ..... 70
- 10. Electrical Fast Transient/ Burst Immunity Test ..... 71**
  - 10.1. Test Procedure ..... 71
  - 10.2. Test Severity Levels ..... 71
  - 10.3. TEST SETUP ..... 72
  - 10.4. Measurement Equipment..... 72
  - 10.5. Test Result and Data ..... 73
  - 10.6. Test Photographs ..... 74
- 11. Surge Immunity Test ..... 75**
  - 11.1. Test Procedure ..... 75
  - 11.2. Test Severity Level ..... 75
  - 11.3. TEST SETUP ..... 76
  - 11.4. Measurement Equipment..... 76
  - 11.5. Test Result and Data ..... 77
  - 11.6. Test Photographs ..... 78
- 12. Conduction Disturbances induced by Radio-Frequency Fields ..... 79**
  - 12.1. Test Procedure ..... 79
  - 12.2. Test Severity Levels ..... 79
  - 12.3. TEST SETUP ..... 80
  - 12.4. Measurement Equipment..... 80
  - 12.5. Test Result and Data ..... 81
  - 12.6. Test Photographs ..... 82
- 13. Power Frequency Magnetic Field Immunity Test ..... 83**
  - 13.1. Test Setup ..... 83
  - 13.2. Test Severity Levels ..... 83
  - 13.3. Measurement Equipment..... 83
  - 13.4. Test Result and Data ..... 84
  - 13.5. Test Photographs ..... 85
- 14. Voltage Dips and Voltage Interruptions Immunity Test Setup ..... 86**
  - 14.1. Test Conditions..... 86
  - 14.2. TEST SETUP ..... 86
  - 14.3. Measurement Equipment..... 86
  - 14.4. Test Result and Data ..... 87
  - 14.5. Test Photographs ..... 88
- 15. Photographs of EUT ..... 89**



### History of this test report

ORIGINAL.

Additional attachment as following record:

Report No	Version	Date	Description
SECE1704218	Rev 01	May 16, 2017	Initial Issue



## 1. Summary of Test Procedure and Test Results

EMISSION[EN55032: 2012+AC 2013]			
Standard	Item	Result	Remarks
EN55032: 2012+AC 2013 AS/NZS CISPR 32 : 2013 CISPR 32 : 2015	Conducted (Power Port)	PASS	Meets Class B Limit Minimum passing margin(AV) is -5.15 dB at 0.2140 MHz
	Conducted (Telecom port)	N/A	N/A
	Radiated	PASS	Meets Class B Limit Minimum passing margin(QP) is -4.81 dB at 220.3100 MHz
EN 61000-3-2: 2014	Harmonic current emissions	PASS	Meet Class D Limit
EN61000-3-3:2013	Voltage fluctuations & flicker	PASS	Meets the requirements

IMMUNITY [EN 55024: 2010]			
Standard	Item	Result	Remarks
IEC 61000-4-2: 2008	ESD	PASS	Meets the requirements of Performance Criterion A
IEC 61000-4-3: 2006+A1:2007+A2:2010	RS	PASS	Meets the requirements of Performance Criterion A
IEC 61000-4-4: 2012	EFT	PASS	Meets the requirements of Performance Criterion A
IEC 61000-4-5:2014	Surge	PASS	Meets the requirements of Performance Criterion A
IEC 61000-4-6:2013	CS	PASS	Meets the requirements of Performance Criterion A
IEC 61000-4-8:2009	PFMF	PASS	Meets the requirements of Performance Criterion A
IEC 61000-4-11:2004	Voltage dips & voltage variations	PASS	Meets the requirements of Voltage Dips: 1) >95% reduction Performance Criterion B 2) 30% reduction Performance Criterion B Voltage Interruptions: 1) >95% reduction Performance Criterion C



## 2. Immunity Testing Performance Criteria Definition

<b>Criteria A:</b>	The apparatus shall continue to operate as intended without operator intervention. No degradation of performance or loss of function is allowed below a performance level specified by the manufacturer, when the apparatus is used as intended. The performance level may be replaced by a permissible loss of performance. If the manufacturer does not specify the minimum performance level or the permissible performance loss, then either of these may be derived from the product description and documentation, and by what the user may reasonably expect from the equipment if used as intended.
<b>Criteria B:</b>	After test, the apparatus shall continue to operate as intended without operator intervention. No degradation of performance or loss of function is allowed, after the application of the phenomenon below a performance level specified by the manufacturer, when the apparatus is used as intended. The performance level may be replaced by a permissible loss of performance.  During the test, degradation of performance is however allowed. However, no change of operating state if stored data is allowed to persist after the test. If the manufacturer does not specify the minimum performance level or the permissible performance loss, then either of these may be derived from the product description and documentation, and by what the user may reasonably expect from the equipment if used as intended.
<b>Criteria C:</b>	Temporary loss of function is allowed, provided the functions is self-recoverable or can be restored by the operation of controls by the user in accordance with the manufacturer instructions.  Functions, and/or information stored in non-volatile memory, or protected by a battery backup, shall not be lost.



### 3. Test Configuration of Equipment under Test

#### 3.1. Feature of Equipment under Test

<b>Product Name:</b>	LCD Monitor
<b>Model Name:</b>	*220*****, 215LM00071 (The "*" could be any alphanumeric character including blank for marketing differentiation.)
<b>Housing material:</b>	Plastic case
<b>EUT Highest Frequency:</b>	148.5MHz
<b>EUT Power Rating:</b>	Input:100-240V, 50-60Hz 3Pin Power Port
<b>AC Power Cord Type:</b>	Non-shielded, 1.2m&1.5m&1.8m

Note: Please refer to user manual.

#### I/O PORT:

I/O PORT TYPE	Quantity
1). HDMI Port	1
2). VGA Port	1
3). Audio Port	1
4). Power Port	1





### 3.2. Test Manner

#### Test Manner

- a. During testing, the interface cables and equipment positions were varied according to Europe Standard.
- a. Running "H" pattern and Colour bars.
- c During the test, connect the Computer, USB Keyboard, USB Mouse, Earphone and EUT, make the EUT at the test mode.
- d Adjust the EUT, then test.

The pre-test for CE/RE modes

Test Mode 1	Full system (VGA mode 1920*1080@60Hz) Signal from PC (230V/50Hz)
Test Mode 2	Full system (VGA mode 1024*768@75Hz) Signal from PC (230V/50Hz)
Test Mode 3	Full system (VGA mode 640*480@60Hz) Signal from PC (230V/50Hz)
Test Mode 4	Full system (HDMI mode 1920*1080@60Hz) Signal from PC(230V/50Hz)
Test Mode 5	Full system (HDMI mode 1024*768@75Hz) Signal from PC (230V/50Hz)
Test Mode 6	Full system (HDMI mode 640*480@60Hz) Signal from PC (230V/50Hz)
Test Mode 7	Full system (HDMI mode 1080P) Signal from DVD (230V/50Hz)
Test Mode 8	Full system (HDMI mode 1080P) Signal from DVD (110V/50Hz)
Test Mode 9	Full system (VGA mode 1920*1080@60Hz) Signal from PC (110V/60Hz)
Test Mode 10	Full system (HDMI mode 1920*1080@60Hz) Signal from PC (110V/60Hz)

“Test mode 1,4,9,10” were reported as final data.

The pre-test for H&F/EMS modes

Test Mode 1	Full system (VGA mode 1920*1080@60Hz) Signal from PC
Test Mode 2	Full system (VGA mode 1024*768@75Hz) Signal from PC
Test Mode 3	Full system (VGA mode 640*480@60Hz) Signal from PC
Test Mode 4	Full system (HDMI mode 1920*1080@60Hz) Signal from PC
Test Mode 5	Full system (HDMI mode 1024*768@75Hz) Signal from PC
Test Mode 6	Full system (HDMI mode 640*480@60Hz) Signal from PC
Test Mode 7	Full system (HDMI mode 1080P) Signal from DVD

“Test mode 1,4” were reported as final data.

The maximum operating frequency is above 108MHz, the test frequency range is from 1GHz to 6GHz.



### 3.3. Description of Support Unit

No.	Device	Manufacturer	Model No.	Description
1	Computer	HP	HP Compaq Elite 8200 MTPC	Non-Shielded, 1.8m(R33001)
2	USB Keyboard	DELL	SK-8115	N/A
3	USB Mouse	DELL	G0K02XYK	N/A
4	Earphone	Edifier	N/A	N/A

No.	Cable	Quantity	Description
A	USB Cable	1	Shielded, 1.8m, with one ferrite core bonded
B	USB Cable	1	Shielded, 1.2m
C	VGA Cable	1	Shielded, 1.2m&1.5m&1.8m, with two ferrites core bonded
D	HDMI Cable	1	Shielded, 1.2m&1.5m&1.8m
E	Audio Cable	1	Non-Shielded, 1.8m



## 3.4. General Information of Test

<input type="checkbox"/>	Test Site	<b>CerpPASS Technology Corporation Test Laboratory</b> Address: No.10, Ln. 2, Lianfu St., Luzhu Dist., Taoyuan City 33848, Taiwan (R.O.C.) Tel:+886-3-3226-888 Fax:+886-3-3226-881 Address: No.68-1, Shihbachongsi, Shihding Township, New Taipei City 223, Taiwan, R.O.C. Tel: +886-2-2663-8582
	FCC	TW1079, TW1061,390316, 228391, 641184
	IC	4934B-1, 4934E-1, 4934E-2
	VCCI	T-2205 for Telecommunication Test C-4663 for Conducted emission test R-3428, R-4218 for Radiated emission test G-812, G-813 for radiated disturbance above 1GHz
<input checked="" type="checkbox"/>	Test Site	<b>CerpPASS Technology (Suzhou) Co.,Ltd</b> Address: No.66,Tangzhuang Road, Suzhou Industrial Park, Jiangsu 215006, China Tel: +86-512-6917-5888 Fax: +86-512-6917-5666
	FCC	331395
	VCCI	T-1945 for Telecommunication Test C-2919 for Conducted emission test R-2670 for Radiated emission test G-227 for radiated disturbance above 1GHz
Frequency Range Investigated:		Conducted: from 150kHz to 30 MHz Radiation: from 30 MHz to 6000MHz
Test Distance :		The test distance of radiated emission below 1GHz from antenna to EUT is 10 M. The test distance of radiated emission above 1GHz from antenna to EUT is 3 M.



### 3.5. Measurement Uncertainty

Where relevant, the following measurement uncertainty levels have been estimated for tests performed on the EUT as specified in CISPR 16-4-2:

Measurement	Frequency	Uncertainty
Conducted emissions(LINE)	9KHz-30MHz	+/- 0.7738 dB
Conducted emissions(NEUTRAL)	9KHz-30MHz	+/- 0.7886 dB

Measurement	Polarity	Frequency	Uncertainty
Radiated emissions (below 1GHz)	H	30MHz ~ 200MHz	+/- 3.8909dB
		200MHz ~1000MHz	+/- 3.6555dB
	V	30MHz ~ 200MHz	+/- 3.8948dB
		200MHz ~1000MHz	+/- 3.6538dB
Radiated emissions (above 1GHz)	H	1000MHz ~18000MHz	+/- 3.8948 dB
		18000MHz ~40000MHz	+/-3.8844dB
	V	1000MHz ~18000MHz	+/- 3.8906dB
		18000MHz ~40000MHz	+/- 3.8744dB

Measurement	Uncertainty
ESD—Rise time tr	10%
ESD—Peak current Ip	6%
ESD—Current at 30 ns	6%
ESD—Current at 60 ns	6%
ESD- Charging voltage	1%
RS above 1GHz	±2.37dB
RS under 1GHz	±3.83dB
EFT—Rise time tr	4%
EFT—Peak current Ip	4%
EFT—Current	4%
Surge—Rise time tr	4%



Surge—Peak current $I_p$	4%
Surge—Current	4%
CS-CND	$\pm 0.80\text{dB}$
CS-Clamp	$\pm 1.06\text{dB}$

This uncertainty represents an expanded uncertainty expressed at approximately the 95% confidence level using a coverage factor of  $k=2$ .

Consistent with industry standard (e.g. CISPR 22: 2008, clause 11, Measurement Uncertainty) determining compliance with the limits shall be based on the results of the compliance measurement. Consequently the measured emissions being less than the maximum allowed emission result in this being a compliant test or passing test.



## 4. Test of Conducted Emission

### 4.1. Test Limit

Conducted Emissions were measured from 150 kHz to 30 MHz with a bandwidth of 9 kHz and return leads of the EUT according to the methods defined in European Standard EN 55032.

**Table A.8 – Requirements for conducted emissions from the AC mains power ports of Class A equipment**

Applicable to				
1. AC mains power ports (3.1.1)				
Table clause	Frequency range MHz	Coupling device (see Table A.7)	Detector type / bandwidth	Class A limits dB( $\mu$ V)
A8.1	0,15 – 0,5	AMN	Quasi Peak / 9 kHz	79
	0,5 – 30			73
A8.2	0,15 – 0,5	AMN	Average / 9 kHz	66
	0,5 – 30			60
NOTE Apply A8.1 and A8.2 across the entire frequency range.				

**Table A.9 – Requirements for conducted emissions from the AC mains power ports of Class B equipment**

Applicable to				
1. AC mains power ports (3.1.1)				
Table clause	Frequency range MHz	Coupling device (see Table A.7)	Detector type / bandwidth	Class B limits dB( $\mu$ V)
A9.1	0,15 – 0,5	AMN	Quasi Peak / 9 kHz	66 – 56
	0,5 – 5			56
	5 – 30			60
A9.2	0,15 – 0,5	AMN	Average / 9 kHz	56 – 46
	0,5 – 5			46
	5 – 30			50
NOTE Apply A9.1 and A9.2 across the entire frequency range.				



**Table A.10 – Requirements for asymmetric mode conducted emissions from Class A equipment**

<b>Applicable to</b>					
1. wired network ports (3.1.30) 2. optical fibre ports (3.1.24) with metallic shield or tension members 3. antenna ports (3.1.3)					
<b>Table clause</b>	<b>Frequency range MHz</b>	<b>Coupling device (see Table A.7)</b>	<b>Detector type / bandwidth</b>	<b>Class A voltage limits dB(μV)</b>	<b>Class A current limits dB(μA)</b>
A10.1	0,15 – 0,5	AAN	Quasi Peak / 9 kHz	97 – 87	n/a
	0,5 – 30			87	
	0,15 – 0,5	AAN	Average / 9 kHz	84 – 74	
	0,5 – 30			74	
A10.2	0,15 – 0,5	CVP and current probe	Quasi Peak / 9 kHz	97 – 87	53 – 43
	0,5 – 30			87	43
	0,15 – 0,5	CVP and current probe	Average / 9 kHz	84 – 74	40 – 30
	0,5 – 30			74	30
A10.3	0,15 – 0,5	Current Probe	Quasi Peak / 9 kHz	n/a	53 – 43
	0,5 – 30				43
	0,15 – 0,5	Current Probe	Average / 9 kHz		40 – 30
	0,5 – 30				30
NOTE 1 The choice of coupling device and measurement procedure is defined in Annex C.					
NOTE 2 AC mains power ports shall meet the limits given in Table A.8.					
NOTE 3 The test shall cover the entire frequency range.					
NOTE 4 The application of the voltage and/or current limits is dependent on the measurement procedure used. Refer to Table C.1 for applicability.					
NOTE 5 Testing is required at only one EUT supply voltage and frequency.					
NOTE 6 Applicable to ports listed above and intended to connect to cables longer than 3 m.					



**Table A.11 – Requirements for asymmetric mode conducted emissions from Class B equipment**

<b>Applicable to</b>					
1. wired network ports (3.1.30) 2. optical fibre ports (3.1.24) with metallic shield or tension members 3. broadcast receiver tuner ports (3.1.8) 4. antenna ports (3.1.3)					
<b>Table clause</b>	<b>Frequency range MHz</b>	<b>Coupling device (see Table A.7)</b>	<b>Detector type / bandwidth</b>	<b>Class B voltage limits dB(μV)</b>	<b>Class B current limits dB(μA)</b>
A11.1	0,15 – 0,5	AAN	Quasi Peak / 9 kHz	84 – 74	n/a
	0,5 – 30			74	
	0,15 – 0,5	AAN	Average / 9 kHz	74 – 64	
	0,5 – 30			64	
A11.2	0,15 – 0,5	CVP and current probe	Quasi Peak / 9 kHz	84 – 74	40 – 30
	0,5 – 30			74	30
	0,15 – 0,5	CVP and current probe	Average / 9 kHz	74 – 64	30 – 20
	0,5 – 30			64	20
A11.3	0,15 – 0,5	Current Probe	Quasi Peak / 9 kHz	n/a	40 – 30
	0,5 – 30				30
	0,15 – 0,5	Current Probe	Average / 9 kHz		30 – 20
	0,5 – 30				20
NOTE 1 The choice of coupling device and measurement procedure is defined in Annex C.  NOTE 2 Screened ports including TV broadcast receiver tuner ports are tested with a common-mode impedance of 150 Ω. This is typically accomplished with the screen terminated by 150 Ω to earth.  NOTE 3 AC mains power ports shall meet the limits given in Table A.9.  NOTE 4 The test shall cover the entire frequency range.  NOTE 5 The application of the voltage and/or current limits is dependent on the measurement procedure used. Refer to Table C.1 for applicability.  NOTE 6 Testing is required at only one EUT supply voltage and frequency.  NOTE 7 Applicable to ports listed above and intended to connect to cables longer than 3 m.					







#### 4.4. Measurement Equipment

Instrument/Ancillary	Manufacturer	Model No.	Serial No.	Calibration Date	Valid Date.
Test Receiver	R&S	ESCI	100565	2016.07.07	2017.07.06
AMN	R&S	ESH2-Z5	100182	2016.08.31	2017.08.30
Two-Line V-Network	R&S	ENV216	100325	/	/
ISN	FCC	FCC-TLISN-T2-02	20379	2017.03.22	2018.03.21
ISN	FCC	FCC-TLISN-T4-02	20380	2016.06.24	2017.06.23
ISN	FCC	FCC-TLISN-T8-02	20381	2016.11.29	2017.11.28
ISN	TESEQ	ISN ST08	30175	2016.08.31	2017.08.30
LISN	FCC	FCC-LISN-50-200-2-02	112087	2016.08.31	2017.08.30
Current Probe	R&S	EZ-17	100303	2017.03.22	2018.03.21
Passive Voltage Probe	R&S	ESH2-Z3	100026	2017.03.22	2018.03.21
Pulse Limiter	R&S	ESH3-Z2	100529	2017.03.22	2018.03.21
Temperature/ Humidity Meter	Zhicheng	ZC1-11	CEP-TH-004	2017.03.28	2018.03.27
EZ-EMC	Fala	Ver CT3A1	N/A	N/A	N/A



### 4.5. Test Result and Data

#### 4.5.1 Conducted Emission for Power Port Test Data

Test Mode :	Mode 1: Full system (VGA mode 1920*1080@60Hz) Signal from PC (230V/50Hz)		
AC Power :	AC 230V/50Hz	Phase :	LINE
Equipment :	LCD Monitor	Model No :	215LM00071
Temperature :	23°C	Humidity :	56%
Pressure(mbar) :	1001	Date:	2017/05/07

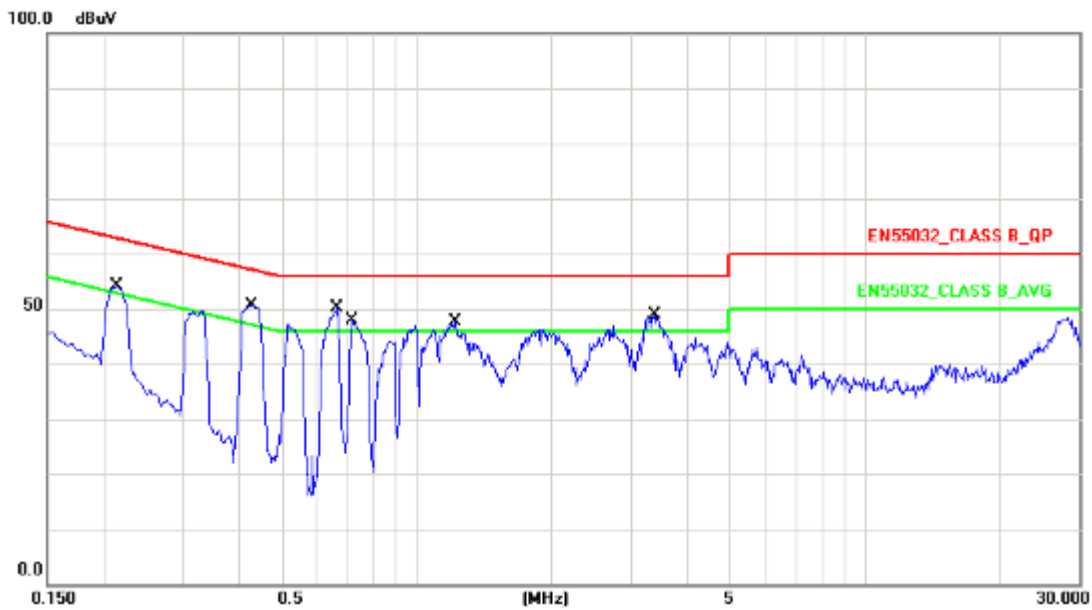

No.	Frequency (MHz)	Factor (dB)	Reading (dBuV)	Level (dBuV)	Limit (dBuV)	Margin (dB)	Detector
1	0.2140	10.12	41.75	51.87	63.04	-11.17	QP
2	0.2140	10.12	37.77	47.89	53.04	-5.15	AVG
3	0.4300	10.15	39.32	49.47	57.25	-7.78	QP
4	0.4300	10.15	31.46	41.61	47.25	-5.64	AVG
5	0.6660	10.15	37.54	47.69	56.00	-8.31	QP
6	0.6660	10.15	20.43	30.58	46.00	-15.42	AVG
7	0.7180	10.15	36.16	46.31	56.00	-9.69	QP
8	0.7180	10.15	18.62	28.77	46.00	-17.23	AVG
9	1.2180	10.16	33.98	44.14	56.00	-11.86	QP
10	1.2180	10.16	17.74	27.90	46.00	-18.10	AVG
11	3.3860	10.19	34.37	44.56	56.00	-11.44	QP
12	3.3860	10.19	23.64	33.83	46.00	-12.17	AVG

Note: Measurement Level = Reading Level + Correct Factor



Test Mode :	Mode 1: Full system (VGA mode 1920*1080@60Hz) Signal from PC (230V/50Hz)		
AC Power :	AC 230V/50Hz	Phase :	NEUTRAL
Equipment :	LCD Monitor	Model No :	215LM00071
Temperature :	23°C	Humidity :	56%
Pressure(mbar) :	1001	Date:	2017/05/07

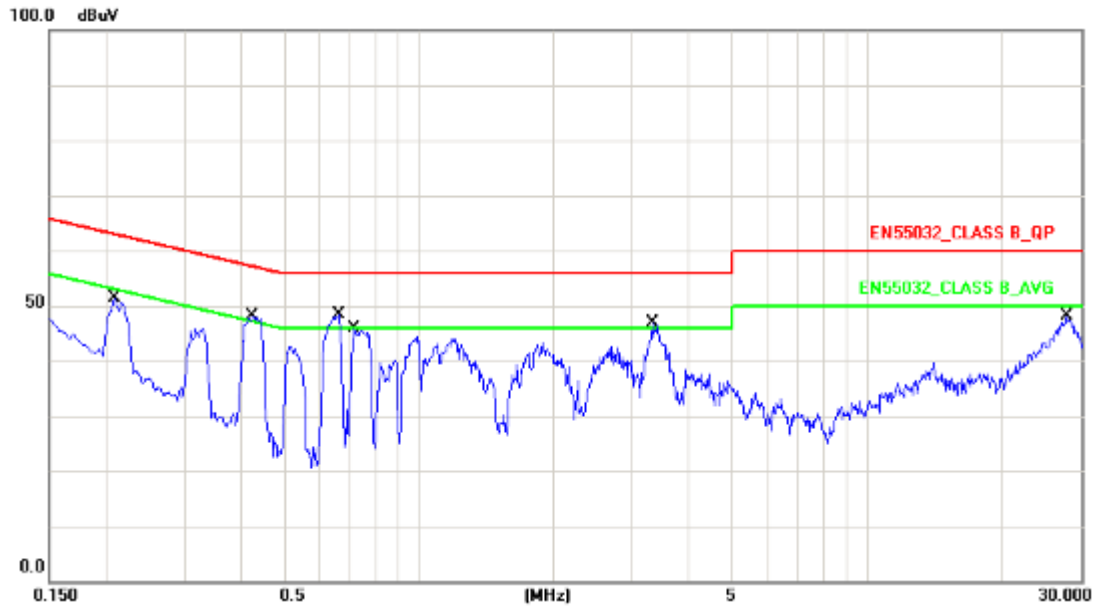

No.	Frequency (MHz)	Factor (dB)	Reading (dBuV)	Level (dBuV)	Limit (dBuV)	Margin (dB)	Detector
1	0.2100	10.13	38.04	48.17	63.20	-15.03	QP
2	0.2100	10.13	32.14	42.27	53.20	-10.93	AVG
3	0.4260	10.15	36.36	46.51	57.33	-10.82	QP
4	0.4260	10.15	28.53	38.68	47.33	-8.65	AVG
5	0.6660	10.16	35.66	45.82	56.00	-10.18	QP
6	0.6660	10.16	18.61	28.77	46.00	-17.23	AVG
7	0.7180	10.16	33.58	43.74	56.00	-12.26	QP
8	0.7180	10.16	16.33	26.49	46.00	-19.51	AVG
9	3.3260	10.21	29.81	40.02	56.00	-15.98	QP
10	3.3260	10.21	17.59	27.80	46.00	-18.20	AVG
11	27.9380	10.30	31.56	41.86	60.00	-18.14	QP
12	27.9380	10.30	25.89	36.19	50.00	-13.81	AVG

Note: Measurement Level = Reading Level + Correct Factor



Test Mode :	Mode 4: Full system (HDMI mode 1920*1080@60Hz) Signal from PC(230V/50Hz)		
AC Power :	AC 230V/50Hz	Phase :	LINE
Equipment :	LCD Monitor	Model No :	215LM00071
Temperature :	23°C	Humidity :	56%
Pressure(mbar) :	1001	Date:	2017/05/07

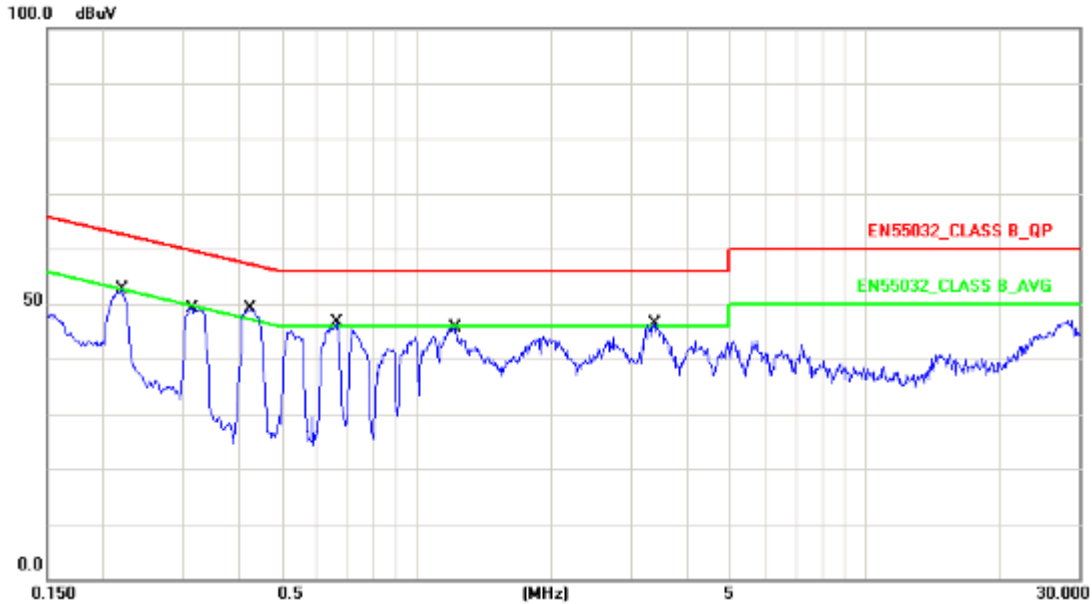

No.	Frequency (MHz)	Factor (dB)	Reading (dBuV)	Level (dBuV)	Limit (dBuV)	Margin (dB)	Detector
1	0.2197	10.12	41.57	51.69	62.83	-11.14	QP
2	0.2197	10.12	34.64	44.76	52.83	-8.07	AVG
3	0.3149	10.14	37.05	47.19	59.84	-12.65	QP
4	0.3149	10.14	29.34	39.48	49.84	-10.36	AVG
5	0.4260	10.15	39.39	49.54	57.33	-7.79	QP
6	0.4260	10.15	31.61	41.76	47.33	-5.57	AVG
7	0.6660	10.15	37.54	47.69	56.00	-8.31	QP
8	0.6660	10.15	20.68	30.83	46.00	-15.17	AVG
9	1.2180	10.16	34.03	44.19	56.00	-11.81	QP
10	1.2180	10.16	17.86	28.02	46.00	-17.98	AVG
11	3.3860	10.19	34.40	44.59	56.00	-11.41	QP
12	3.3860	10.19	23.71	33.90	46.00	-12.10	AVG

Note: Measurement Level = Reading Level + Correct Factor



Test Mode :	Mode 4: Full system (HDMI mode 1920*1080@60Hz) Signal from PC(230V/50Hz)		
AC Power :	AC 230V/50Hz	Phase :	NEUTRAL
Equipment :	LCD Monitor	Model No :	215LM00071
Temperature :	23°C	Humidity :	56%
Pressure(mbar) :	1001	Date:	2017/05/07

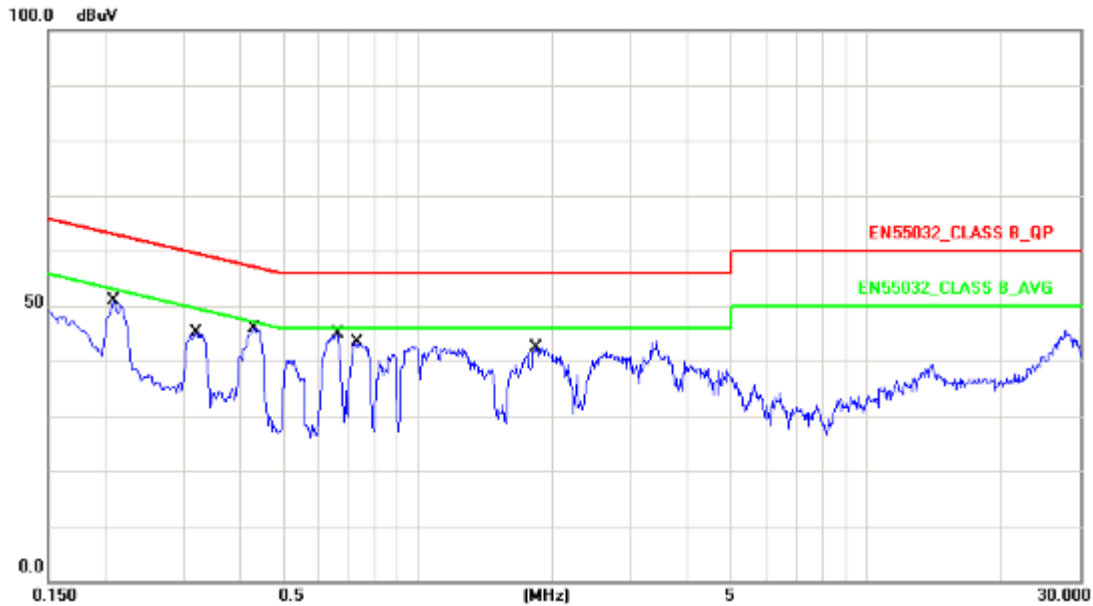

No.	Frequency (MHz)	Factor (dB)	Reading (dBuV)	Level (dBuV)	Limit (dBuV)	Margin (dB)	Detector
1	0.2100	10.13	38.03	48.16	63.20	-15.04	QP
2	0.2100	10.13	32.09	42.22	53.20	-10.98	AVG
3	0.3200	10.14	33.33	43.47	59.70	-16.23	QP
4	0.3200	10.14	26.79	36.93	49.70	-12.77	AVG
5	0.4305	10.15	36.20	46.35	57.24	-10.89	QP
6	0.4305	10.15	28.23	38.38	47.24	-8.86	AVG
7	0.6660	10.16	35.85	46.01	56.00	-9.99	QP
8	0.6660	10.16	18.91	29.07	46.00	-16.93	AVG
9	0.7340	10.16	33.39	43.55	56.00	-12.45	QP
10	0.7340	10.16	20.24	30.40	46.00	-15.60	AVG
11	1.8340	10.18	27.61	37.79	56.00	-18.21	QP
12	1.8340	10.18	15.47	25.65	46.00	-20.35	AVG

Note: Measurement Level = Reading Level + Correct Factor



Test Mode :	Mode 9: Full system (VGA mode 1920*1080@60Hz) Signal from PC (110V/60Hz)		
AC Power :	AC 110V/60Hz	Phase :	LINE
Equipment :	LCD Monitor	Model No :	215LM00071
Temperature :	23°C	Humidity :	56%
Pressure(mbar) :	1001	Date:	2017/05/07

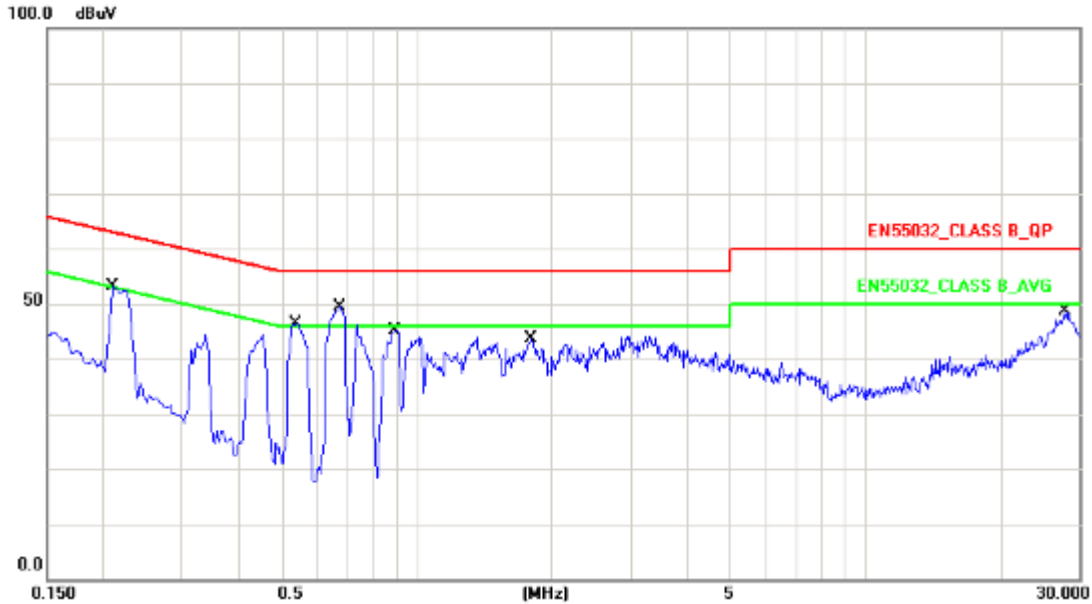

No.	Frequency (MHz)	Factor (dB)	Reading (dBuV)	Level (dBuV)	Limit (dBuV)	Margin (dB)	Detector
1	0.2100	10.12	39.02	49.14	63.20	-14.06	QP
2	0.2100	10.12	26.54	36.66	53.20	-16.54	AVG
3	0.5380	10.16	34.96	45.12	56.00	-10.88	QP
4	0.5380	10.16	24.39	34.55	46.00	-11.45	AVG
5	0.6740	10.15	37.84	47.99	56.00	-8.01	QP
6	0.6740	10.15	25.84	35.99	46.00	-10.01	AVG
7	0.8940	10.15	32.27	42.42	56.00	-13.58	QP
8	0.8940	10.15	20.30	30.45	46.00	-15.55	AVG
9	1.8020	10.17	29.69	39.86	56.00	-16.14	QP
10	1.8020	10.17	17.38	27.55	46.00	-18.45	AVG
11	27.8700	10.44	31.97	42.41	60.00	-17.59	QP
12	27.8700	10.44	26.29	36.73	50.00	-13.27	AVG

Note: Measurement Level = Reading Level + Correct Factor



Test Mode :	Mode 9: Full system (VGA mode 1920*1080@60Hz) Signal from PC (110V/60Hz)		
AC Power :	AC 110V/60Hz	Phase :	NEUTRAL
Equipment :	LCD Monitor	Model No :	215LM00071
Temperature :	23°C	Humidity :	56%
Pressure(mbar) :	1001	Date:	2017/05/07

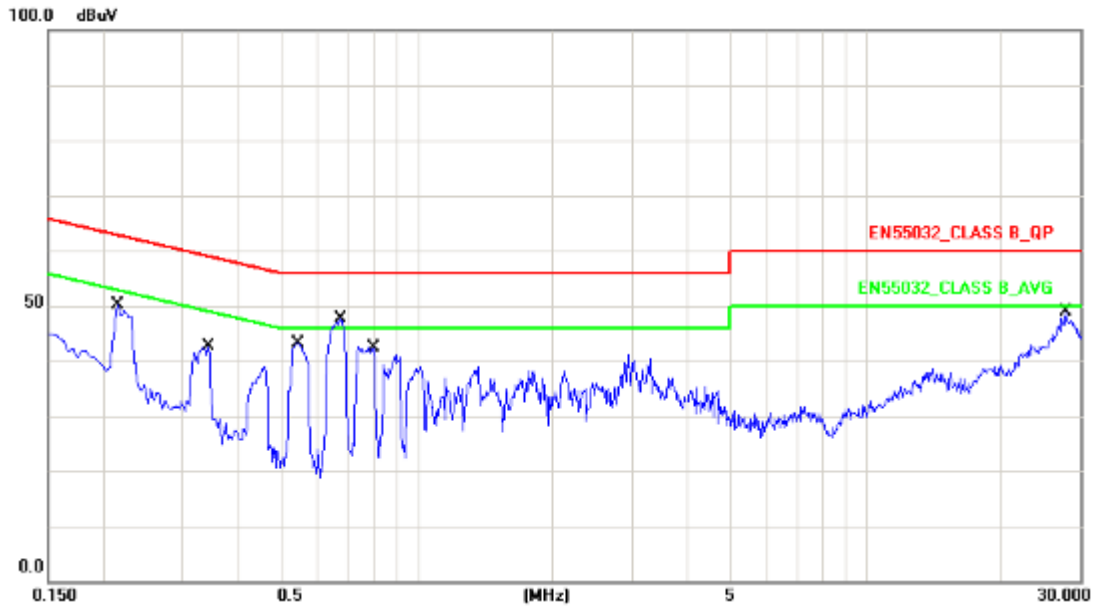

No.	Frequency (MHz)	Factor (dB)	Reading (dBuV)	Level (dBuV)	Limit (dBuV)	Margin (dB)	Detector
1	0.2140	10.13	36.96	47.09	63.04	-15.95	QP
2	0.2140	10.13	27.81	37.94	53.04	-15.10	AVG
3	0.3420	10.14	27.88	38.02	59.15	-21.13	QP
4	0.3420	10.14	15.20	25.34	49.15	-23.81	AVG
5	0.5420	10.15	31.76	41.91	56.00	-14.09	QP
6	0.5420	10.15	22.27	32.42	46.00	-13.58	AVG
7	0.6740	10.16	35.82	45.98	56.00	-10.02	QP
8	0.6740	10.16	24.05	34.21	46.00	-11.79	AVG
9	0.7980	10.16	29.25	39.41	56.00	-16.59	QP
10	0.7980	10.16	11.34	21.50	46.00	-24.50	AVG
11	27.9700	10.30	31.64	41.94	60.00	-18.06	QP
12	27.9700	10.30	25.88	36.18	50.00	-13.82	AVG

Note: Measurement Level = Reading Level + Correct Factor





Test Mode :	Mode 10: Full system (HDMI mode 1920*1080@60Hz) Signal from PC (110V/60Hz)		
AC Power :	AC 110V/60Hz	Phase :	LINE
Equipment :	LCD Monitor	Model No :	215LM00071
Temperature :	23°C	Humidity :	56%
Pressure(mbar) :	1001	Date:	2017/05/07

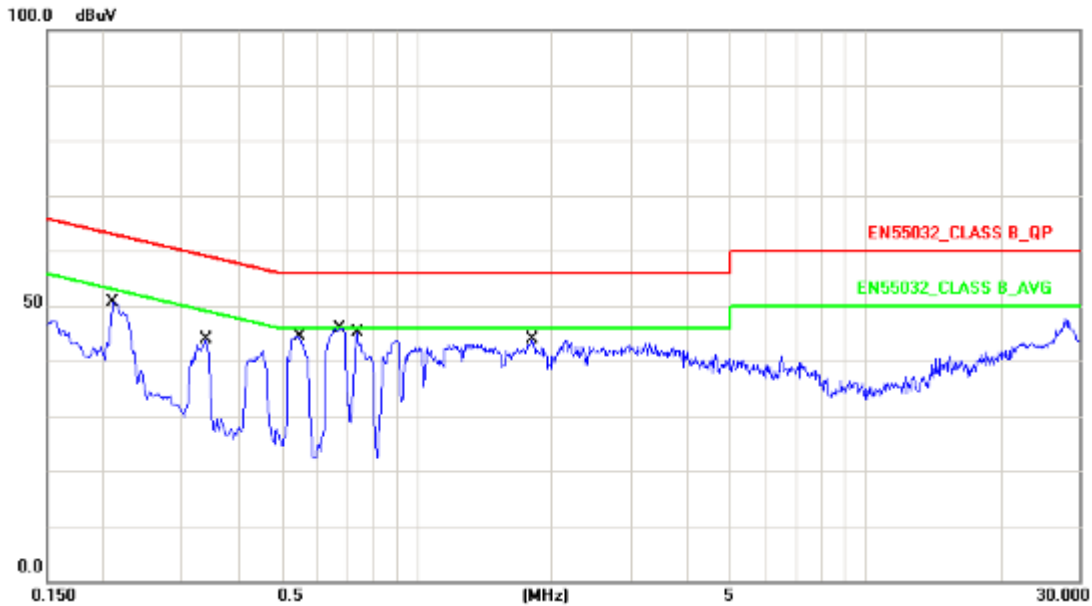

No.	Frequency (MHz)	Factor (dB)	Reading (dBuV)	Level (dBuV)	Limit (dBuV)	Margin (dB)	Detector
1	0.2100	10.12	38.90	49.02	63.20	-14.18	QP
2	0.2100	10.12	26.57	36.69	53.20	-16.51	AVG
3	0.3392	10.14	29.53	39.67	59.22	-19.55	QP
4	0.3392	10.14	20.51	30.65	49.22	-18.57	AVG
5	0.5500	10.16	34.23	44.39	56.00	-11.61	QP
6	0.5500	10.16	24.54	34.70	46.00	-11.30	AVG
7	0.6740	10.15	37.81	47.96	56.00	-8.04	QP
8	0.6740	10.15	25.91	36.06	46.00	-9.94	AVG
9	0.7380	10.15	33.78	43.93	56.00	-12.07	QP
10	0.7380	10.15	16.33	26.48	46.00	-19.52	AVG
11	1.8180	10.17	29.58	39.75	56.00	-16.25	QP
12	1.8180	10.17	16.93	27.10	46.00	-18.90	AVG

Note: Measurement Level = Reading Level + Correct Factor



Test Mode :	Mode 10: Full system (HDMI mode 1920*1080@60Hz) Signal from PC (110V/60Hz)		
AC Power :	AC 110V/60Hz	Phase :	NEUTRAL
Equipment :	LCD Monitor	Model No :	215LM00071
Temperature :	23°C	Humidity :	56%
Pressure(mbar) :	1001	Date:	2017/05/07

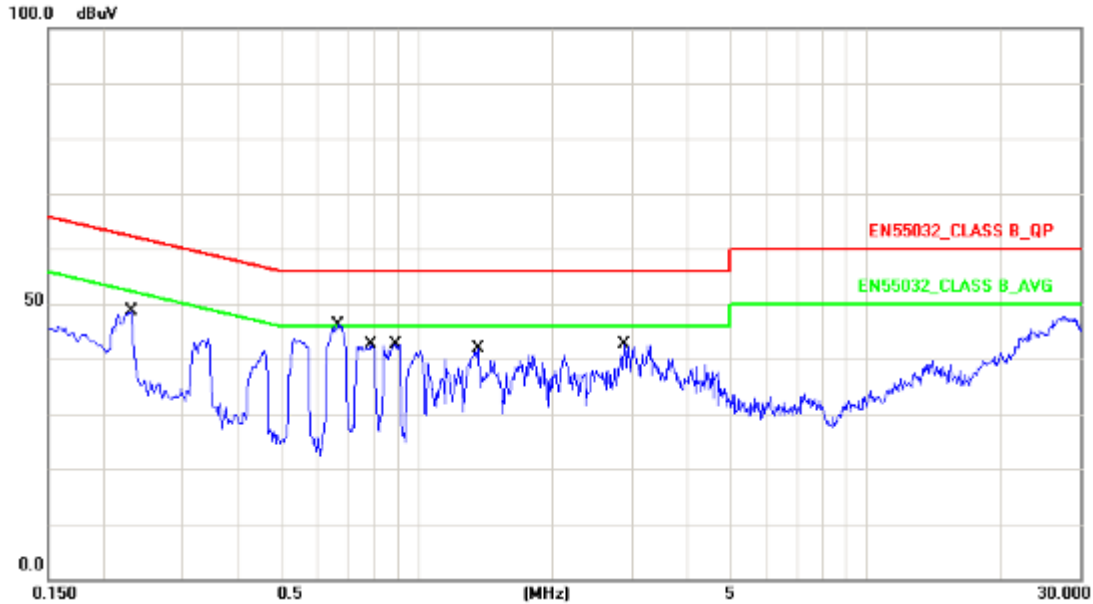

No.	Frequency (MHz)	Factor (dB)	Reading (dBuV)	Level (dBuV)	Limit (dBuV)	Margin (dB)	Detector
1	0.2300	10.13	31.70	41.83	62.45	-20.62	QP
2	0.2300	10.13	17.98	28.11	52.45	-24.34	AVG
3	0.6660	10.16	35.76	45.92	56.00	-10.08	QP
4	0.6660	10.16	24.94	35.10	46.00	-10.90	AVG
5	0.7860	10.16	30.57	40.73	56.00	-15.27	QP
6	0.7860	10.16	18.27	28.43	46.00	-17.57	AVG
7	0.8980	10.17	28.57	38.74	56.00	-17.26	QP
8	0.8980	10.17	16.14	26.31	46.00	-19.69	AVG
9	1.3619	10.18	25.14	35.32	56.00	-20.68	QP
10	1.3619	10.18	9.52	19.70	46.00	-26.30	AVG
11	2.8900	10.20	21.66	31.86	56.00	-24.14	QP
12	2.8900	10.20	8.96	19.16	46.00	-26.84	AVG

Note: Measurement Level = Reading Level + Correct Factor

Test engineer: Sun. Zhang



#### 4.5.2 Conducted Emission for Telecommunication Port Test Data

Note: The EUT doesn't have the telecommunication port.



#### 4.6. Test Photographs

Front View



Rear View

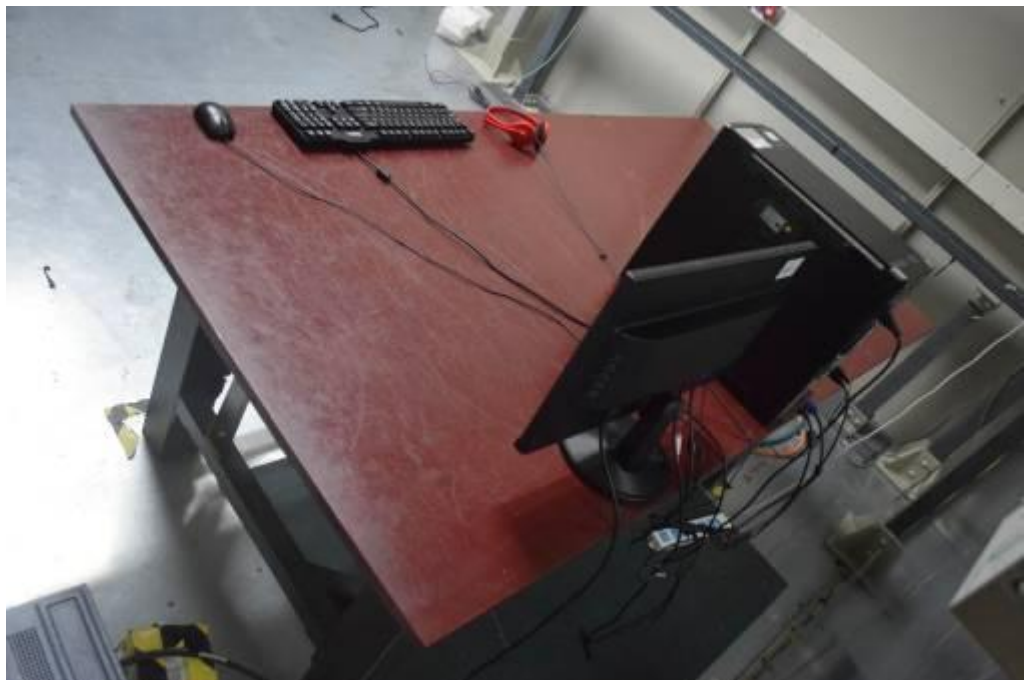



## 5. Test of Radiated Emission

### 5.1. Test Limit

The EUT shall meet the limits of below Table when measured at the measuring distance R in accordance with the methods described in European Standard EN 55032. If the reading on the measuring receiver shows fluctuations close to the limit, the reading shall be observed for at least 15 s at each measurement frequency; the highest reading shall be recorded, with the exception of any brief isolated high reading, which shall be ignored.

**Table 1 – Required highest frequency for radiated measurement**

Highest internal frequency ( $F_x$ )	Highest measured frequency
$F_x \leq 108$ MHz	1 GHz
$108$ MHz $< F_x \leq 500$ MHz	2 GHz
$500$ MHz $< F_x \leq 1$ GHz	5 GHz
$F_x > 1$ GHz	$5 \times F_x$ up to a maximum of 6 GHz

NOTE 1 For FM and TV broadcast receivers,  $F_x$  is determined from the highest frequency generated or used excluding the local oscillator and tuned frequencies.

NOTE 2  $F_x$  is defined in 3.1.19.

Where the  $F_x$  is unknown, the radiated emission measurements shall be performed up to 6 GHz.

**Table A.2 – Requirements for radiated emissions at frequencies up to 1 GHz for Class A equipment**

Table clause	Frequency range MHz	Measurement		Class A limits dB( $\mu$ V/m)
		Distance m	Detector type/ bandwidth	OATS/SAC (see Table A.1)
A2.1	30 – 230	10	Quasi Peak / 120 kHz	40
	230 – 1 000			47
A2.2	30 – 230	3		50
	230 – 1 000			57

NOTE Apply only A2.1 or A2.2 across the entire frequency range.

**Table A.3 – Requirements for radiated emissions at frequencies above 1 GHz for Class A equipment**

Table clause	Frequency range MHz	Measurement		Class A limits dB( $\mu$ V/m)
		Distance m	Detector type/ bandwidth	FSOATS (see Table A.1)
A3.1	1 000 – 3 000	3	Average / 1 MHz	56
	3 000 – 6 000			60
A3.2	1 000 – 3 000		Peak / 1 MHz	76
	3 000 – 6 000			80

NOTE Apply A3.1 and A3.2 across the frequency range from 1 000 MHz to the highest required frequency of measurement derived from Table 1.



**Table A.4 – Requirements for radiated emissions at frequencies up to 1 GHz for Class B equipment**

Table clause	Frequency range MHz	Measurement		Class B limits dB(μV/m)	
		Distance m	Detector type/ bandwidth	OATS/SAC (see Table A.1)	
A4.1	30 – 230	10	Quasi Peak / 120 kHz	30	
	230 – 1 000			37	
A4.2	30 – 230	3		40	
	230 – 1 000			47	

NOTE Apply only table clause A4.1 or A4.2 across the entire frequency range.

**Table A.5 – Requirements for radiated emissions at frequencies above 1 GHz for Class B equipment**

Table clause	Frequency range MHz	Measurement		Class B limits dB(μV/m)	
		Distance m	Detector type/ bandwidth	FSOATS (see Table A.1)	
A5.1	1 000 – 3 000	3	Average/ 1 MHz	50	
	3 000 – 6 000			54	
A5.2	1 000 – 3 000		Peak/ 1 MHz	70	
	3 000 – 6 000			74	

NOTE Apply A5.1 and A5.2 across the frequency range from 1 000 MHz to the highest required frequency of measurement derived from Table 1.

**Table A.6 – Requirements for radiated emissions from FM receivers**

Table clause	Frequency range MHz	Measurement		Class B limit dB(μV/m)		
		Distance m	Detector type/ bandwidth	Fundamental	Harmonics	
				OATS/SAC (see Table A.1)	OATS/SAC (see Table A.1)	
A6.1	30 – 230	10	Quasi peak/ 120 kHz	50	42	
	230 – 300				42	
	300 – 1 000				46	
A6.2	30 – 230	3		Quasi peak/ 120 kHz	60	52
	230 – 300					52
	300 – 1 000					56

NOTE 1 Apply only A.6.1 or A.6.2 across the entire frequency range.

NOTE 2 These relaxed limits apply only to emissions at the fundamental and harmonic frequencies of the local oscillator. Signals at all other frequencies shall be compliant with the limits given in Table A.4.



**Table A.12 – Requirements for conducted differential voltage emissions from Class B equipment**

<b>Applicable to</b>						
1. TV broadcast receiver tuner ports (3.1.8) with an accessible connector						
2. RF modulator output ports (3.1.27)						
3. FM broadcast receiver tuner ports (3.1.8) with an accessible connector						
Table clause	Frequency range MHz	Detector type/ bandwidth	Class B limits dB(μV) 75 Ω			Applicability
			Other	Local Oscillator Fundamental	Local Oscillator Harmonics	
A12.1	30 – 950	For frequencies ≤1 GHz	46	46	46	See NOTE 1
	950 – 2 150		46	54	54	
A12.2	950 – 2 150		46	54	54	See NOTE 2
A12.3	30 – 300		Quasi Peak/ 120 kHz	46	54	50
	300 – 1 000	52				
A12.4	30 – 300	For frequencies ≥1 GHz	46	66	59	See NOTE 4
	300 – 1 000				52	
A12.5	30 – 950	Peak/ 1 MHz	46	76	46	See NOTE 5
	950 – 2 150			n/a	54	

NOTE 1 Television receivers (analogue or digital), video recorders and PC TV broadcast receiver tuner cards working in channels between 30 MHz and 1 GHz, and digital audio receivers.

NOTE 2 Tuner units (not the LNB) for satellite signal reception.

NOTE 3 Frequency modulation audio receivers and PC tuner cards.

NOTE 4 Frequency modulation car radios.

NOTE 5 Applicable to EUTs with RF modulator output ports (for example DVD equipment, video recorders, camcorders and decoders etc.) designed to connect to TV broadcast receiver tuner ports.

NOTE 6 Testing is required at only one EUT supply voltage and frequency.

NOTE 7 The term 'other' refers to all emissions other than the fundamental and the harmonics of the local oscillator.

NOTE 8 The test shall be performed with the device operating at each reception channel.

NOTE 9 The test shall cover the entire frequency range.

## 5.2. Test Procedures

- b. The EUT was placed on a rotatable table top 0.8 meter above ground.
- c. The EUT was set 3/10 meters from the interference receiving antenna which was mounted on the top of a variable height antenna tower.
- d. The table was rotated 360 degrees to determine the position of the highest radiation.
- e. The antenna is a half wave dipole and its height is varied between one meter and four meters above ground to find the maximum value of the field strength both horizontal polarization and vertical polarization of the antenna are set to make the measurement.
- f. For each suspected emission the EUT was arranged to its worst case and then tune the antenna tower (from 1 M to 4 M) and turn table (from 0 degree to 360 degrees) to find the maximum reading.
- g. Set the test-receiver system to Peak Detect Function and specified bandwidth with Maximum Hold Mode.
- h. If the emission level of the EUT in peak mode was 3 dB lower than the limit specified, then testing will be stopped and peak values of EUT will be reported, otherwise, the emissions which do not have 3 dB margin will be repeated one by one using the quasi-peak method and reported.

## 5.3. Typical Test Setup

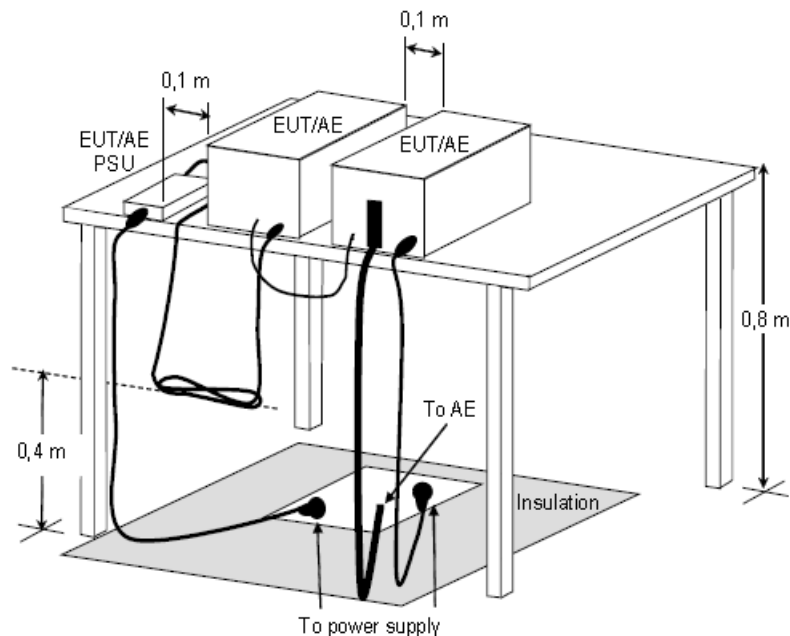

**Figure D.8 – Example measurement arrangement for table-top EUT  
(Radiated emission measurement)**





#### 5.4. Measurement Equipment

Instrument/Ancillary	Manufacturer	Model No.	Serial No.	Calibration Date	Valid Date.
EMI Test Receiver	R&S	ESCI7	100968	2016.07.21	2017.07.20
Preamplifier	Agilent	87405B	My39500554	2017.03.22	2018.03.21
Preamplifier	Agilent	8449B	3008A02342	2017.03.22	2018.03.21
Bilog Antenna	Sunol Science	JB1	A072414-1	2017.04.16	2018.04.15
Broad-Band Horn Antenna	Schwarzbeck	BBHA9120D	9120D-618	2017.04.16	2018.04.15
Spectrum Analyzer	R&S	FSP40	100324	2016.08.02	2017.08.01
Temperature/ Humidity Meter	Zhicheng	ZC1-11	CEP-TH-001	2017.03.28	2018.03.27
EZ-EMC	Fala	Ver CT3A1	N/A	N/A	N/A



### 5.5. Test Result and Data (30MHz ~ 1GHz)

Test Mode :	Mode 1: Full system (VGA mode 1920*1080@60Hz) Signal from PC (230V/50Hz)		
AC Power :	AC 230V/50Hz	Ant. Polarization:	Horizontal
Equipment :	LCD Monitor	Model No :	215LM00071
Temperature :	23°C	Humidity :	56%
Pressure(mbar) :	1001	Date:	2017/05/07

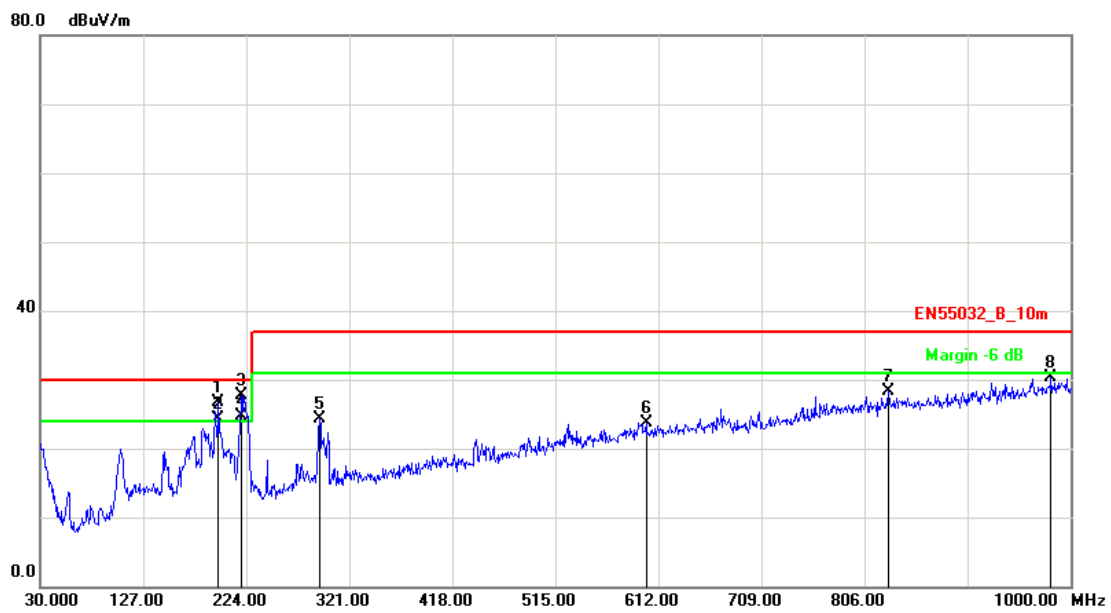

No.	Frequency (MHz)	Factor (dB/m)	Reading (dBuV)	Level (dBuV/m)	Limit (dBuV/m)	Margin (dB)	Det.	Height (cm)	Azimuth (deg)
1	197.8100	-10.09	36.86	26.77	30.00	-3.23	peak	400	192
2	198.0200	-10.07	34.28	24.21	30.00	-5.79	QP	400	192
3	219.1500	-11.84	39.63	27.79	30.00	-2.21	peak	400	145
4	219.2300	-11.85	36.57	24.72	30.00	-5.28	QP	400	145
5	292.8700	-8.78	33.03	24.25	37.00	-12.75	peak	400	213
6	600.3600	-1.24	24.97	23.73	37.00	-13.27	peak	400	295
7	828.3099	2.39	25.96	28.35	37.00	-8.65	peak	400	178
8	981.5700	4.79	25.53	30.32	37.00	-6.68	peak	100	170

Note: Measurement Level = Reading Level + Correct Factor



Test Mode :	Mode 1: Full system (VGA mode 1920*1080@60Hz) Signal from PC (230V/50Hz)		
AC Power :	AC 230V/50Hz	Ant. Polarization:	Vertical
Equipment :	LCD Monitor	Model No :	215LM00071
Temperature :	23°C	Humidity :	56%
Pressure(mbar) :	1001	Date:	2017/05/07

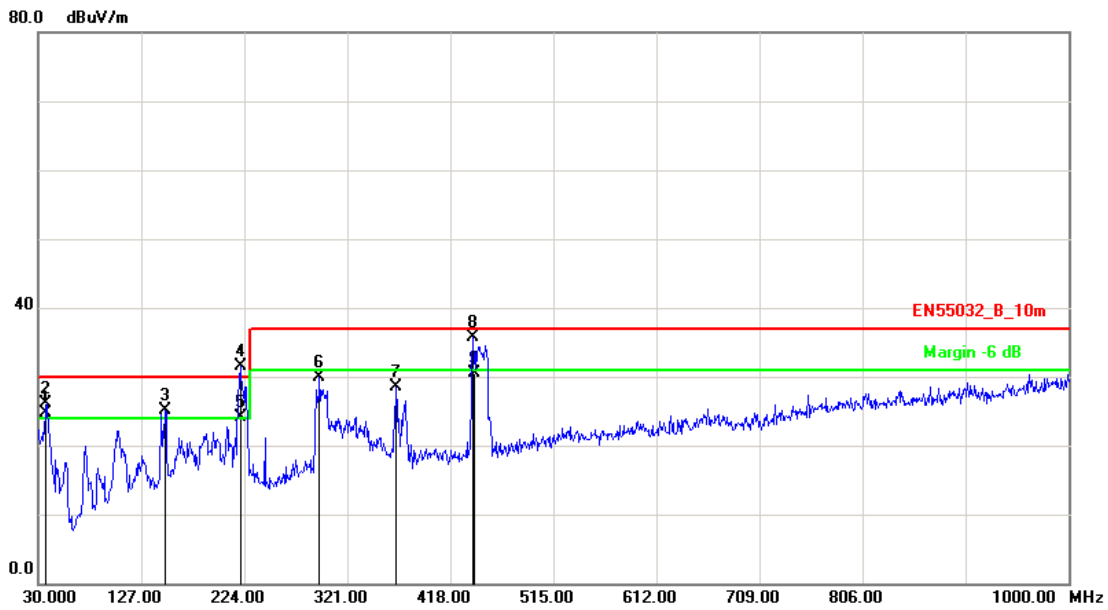

No.	Frequency (MHz)	Factor (dB/m)	Reading (dBuV)	Level (dBuV/m)	Limit (dBuV/m)	Margin (dB)	Det.	Height (cm)	Azimuth (deg)
1	36.6600	-8.07	32.78	24.71	30.00	-5.29	QP	400	246
2	37.7599	-8.86	34.93	26.07	30.00	-3.93	peak	400	246
3	149.3100	-10.62	35.77	25.15	30.00	-4.85	peak	100	166
4	220.1200	-11.92	43.48	31.56	30.00	1.56	peak	100	129
5	220.4400	-11.91	35.95	24.04	30.00	-5.96	QP	100	1
6	294.8100	-8.78	38.76	29.98	37.00	-7.02	peak	100	192
7	366.5900	-6.68	35.24	28.56	37.00	-8.44	peak	400	172
8	439.3400	-4.81	40.55	35.74	37.00	-1.26	peak	400	168
9	440.1800	-4.79	35.21	30.42	37.00	-6.58	QP	400	168

Note: Measurement Level = Reading Level + Correct Factor



Test Mode :	Mode 4: Full system (HDMI mode 1920*1080@60Hz) Signal from PC(230V/50Hz)		
AC Power :	AC 230V/50Hz	Ant. Polarization:	Horizontal
Equipment :	LCD Monitor	Model No :	215LM00071
Temperature :	23°C	Humidity :	56%
Pressure(mbar) :	1001	Date:	2017/05/07

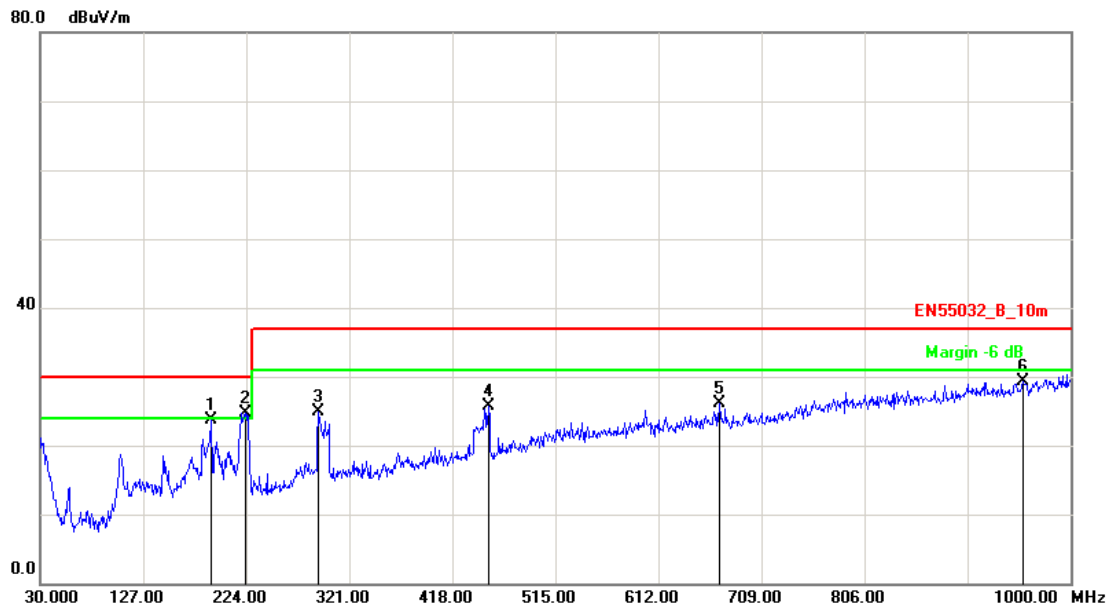

No.	Frequency (MHz)	Factor (dB/m)	Reading (dBuV)	Level (dBuV/m)	Limit (dBuV/m)	Margin (dB)	Det.	Height (cm)	Azimuth (deg)
1	191.0200	-10.62	34.38	23.76	30.00	-6.24	peak	400	360
2	223.0300	-11.77	36.53	24.76	30.00	-5.24	peak	400	122
3	291.8999	-8.79	33.71	24.92	37.00	-12.08	peak	100	191
4	451.9499	-4.51	30.27	25.76	37.00	-11.24	peak	400	226
5	669.2300	-0.12	26.13	26.01	37.00	-10.99	peak	100	165
6	955.3799	4.25	25.10	29.35	37.00	-7.65	peak	400	269

Note: Measurement Level = Reading Level + Correct Factor



Test Mode :	Mode 4: Full system (HDMI mode 1920*1080@60Hz) Signal from PC(230V/50Hz)		
AC Power :	AC 230V/50Hz	Ant. Polarization:	Vertical
Equipment :	LCD Monitor	Model No :	215LM00071
Temperature :	23°C	Humidity :	56%
Pressure(mbar) :	1001	Date:	2017/05/07

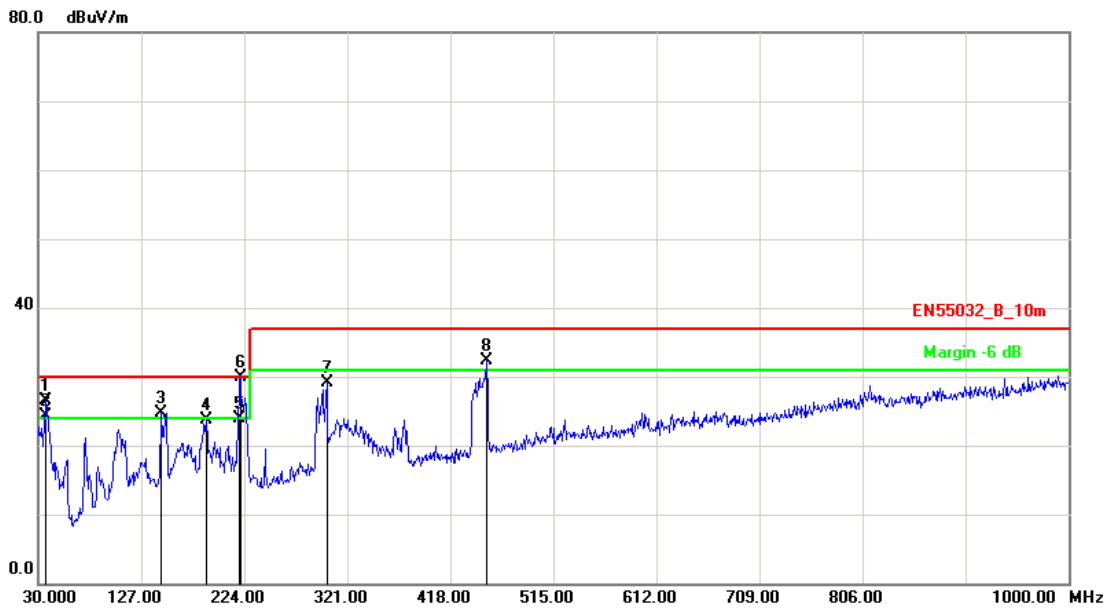

No.	Frequency (MHz)	Factor (dB/m)	Reading (dBuV)	Level (dBuV/m)	Limit (dBuV/m)	Margin (dB)	Det.	Height (cm)	Azimuth (deg)
1	36.7900	-8.16	34.66	26.50	30.00	-3.50	peak	100	84
2	37.1400	-8.42	32.63	24.21	30.00	-5.79	QP	100	84
3	145.4299	-10.54	35.34	24.80	30.00	-5.20	peak	100	163
4	188.1100	-10.85	34.63	23.78	30.00	-6.22	peak	100	120
5	219.9800	-11.93	35.79	23.86	30.00	-6.14	QP	100	152
6	220.1200	-11.92	41.88	29.96	30.00	-0.04	peak	100	152
7	301.6000	-8.70	37.73	29.03	37.00	-7.97	peak	100	173
8	451.9500	-4.51	36.78	32.27	37.00	-4.73	peak	100	183

Note: Measurement Level = Reading Level + Correct Factor



Test Mode :	Mode 9: Full system (VGA mode 1920*1080@60Hz) Signal from PC (110V/60Hz)		
AC Power :	AC 110V/60Hz	Ant. Polarization:	Horizontal
Equipment :	LCD Monitor	Model No :	215LM00071
Temperature :	23°C	Humidity :	56%
Pressure(mbar) :	1001	Date:	2017/05/07

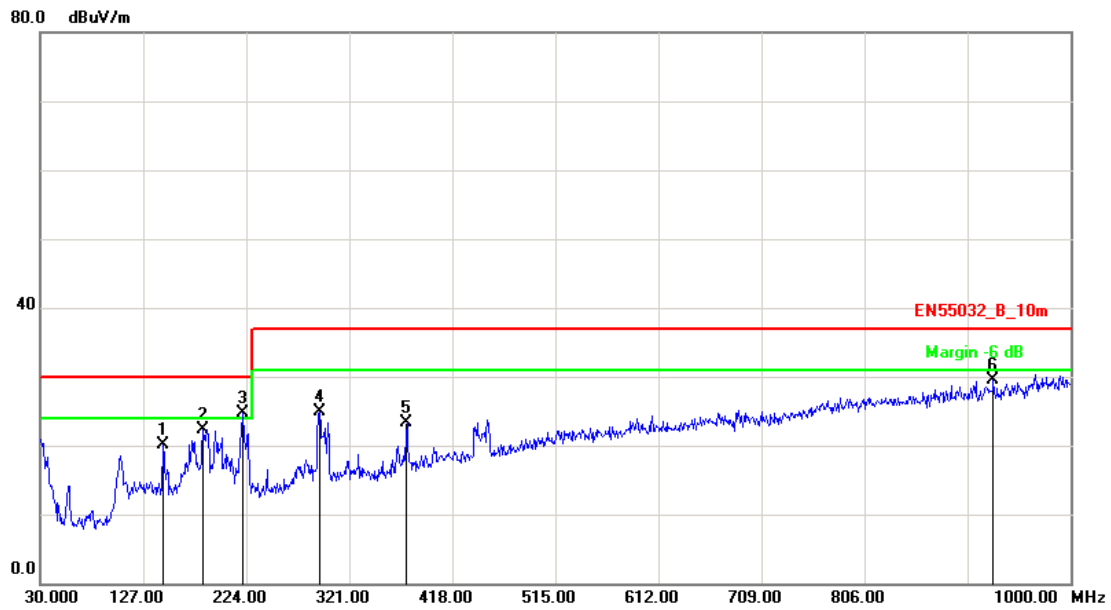

No.	Frequency (MHz)	Factor (dB/m)	Reading (dBuV)	Level (dBuV/m)	Limit (dBuV/m)	Margin (dB)	Det.	Height (cm)	Azimuth (deg)
1	145.4299	-10.54	30.62	20.08	30.00	-9.92	peak	200	277
2	183.2599	-11.23	33.61	22.38	30.00	-7.62	peak	100	5
3	221.0900	-11.87	36.55	24.68	30.00	-5.32	peak	400	203
4	292.8700	-8.78	33.71	24.93	37.00	-12.07	peak	400	188
5	375.3199	-6.47	29.74	23.27	37.00	-13.73	peak	100	47
6	927.2500	3.78	25.65	29.43	37.00	-7.57	peak	100	0

Note: Measurement Level = Reading Level + Correct Factor



Test Mode :	Mode 9: Full system (VGA mode 1920*1080@60Hz) Signal from PC (110V/60Hz)		
AC Power :	AC 110V/60Hz	Ant. Polarization:	Vertical
Equipment :	LCD Monitor	Model No :	215LM00071
Temperature :	23°C	Humidity :	56%
Pressure(mbar) :	1001	Date:	2017/05/07

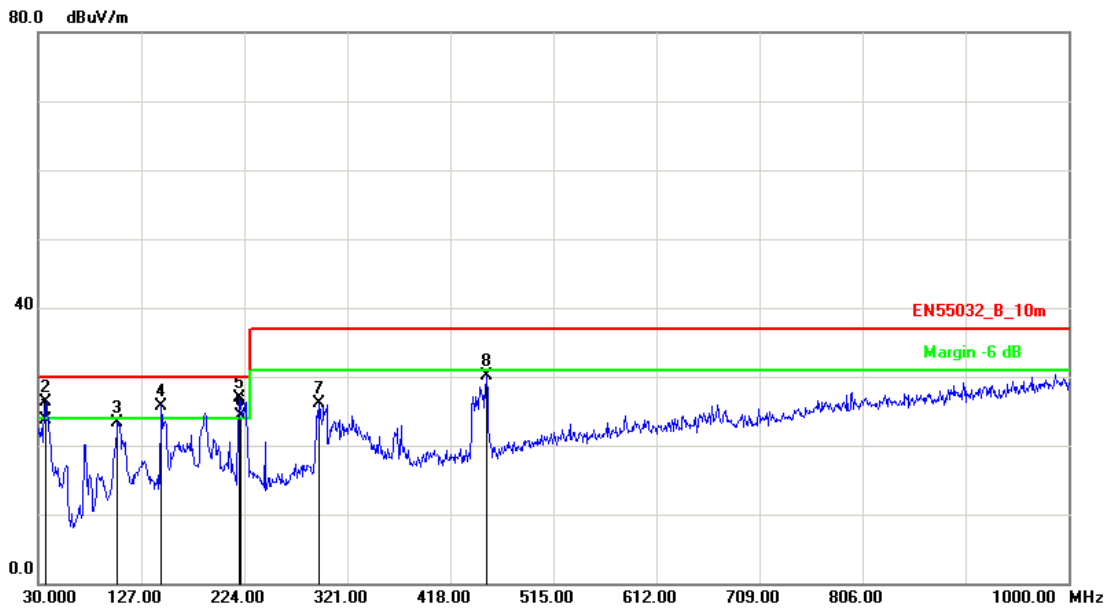

No.	Frequency (MHz)	Factor (dB/m)	Reading (dBuV)	Level (dBuV/m)	Limit (dBuV/m)	Margin (dB)	Det.	Height (cm)	Azimuth (deg)
1	37.6500	-8.78	32.54	23.76	30.00	-6.24	QP	400	92
2	37.7599	-8.86	35.09	26.23	30.00	-3.77	peak	400	92
3	104.6900	-12.80	36.17	23.37	30.00	-6.63	peak	100	103
4	145.4299	-10.54	36.34	25.80	30.00	-4.20	peak	100	152
5	219.1500	-11.84	38.65	26.81	30.00	-3.19	peak	100	330
6	220.1400	-11.92	36.20	24.28	30.00	-5.72	QP	100	330
7	294.8100	-8.78	34.88	26.10	37.00	-10.90	peak	100	183
8	451.9500	-4.51	34.53	30.02	37.00	-6.98	peak	100	197

Note: Measurement Level = Reading Level + Correct Factor



Test Mode :	Mode 10: Full system (HDMI mode 1920*1080@60Hz) Signal from PC (110V/60Hz)		
AC Power :	AC 110V/60Hz	Ant. Polarization:	Horizontal
Equipment :	LCD Monitor	Model No :	215LM00071
Temperature :	23°C	Humidity :	56%
Pressure(mbar) :	1001	Date:	2017/05/07

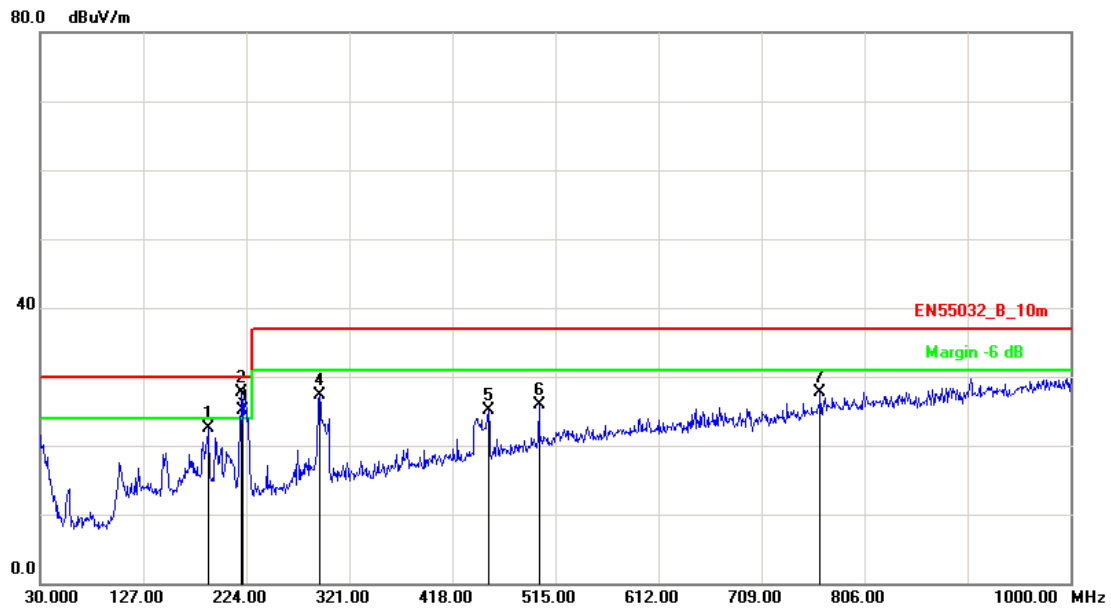

No.	Frequency (MHz)	Factor (dB/m)	Reading (dBuV)	Level (dBuV/m)	Limit (dBuV/m)	Margin (dB)	Det.	Height (cm)	Azimuth (deg)
1	188.1100	-10.85	33.28	22.43	30.00	-7.57	peak	400	206
2	219.1500	-11.84	39.50	27.66	30.00	-2.34	peak	400	121
3	220.3100	-11.91	37.10	25.19	30.00	-4.81	QP	400	121
4	292.8700	-8.78	36.05	27.27	37.00	-9.73	peak	100	185
5	451.9499	-4.51	29.71	25.20	37.00	-11.80	peak	400	238
6	499.4800	-3.03	28.84	25.81	37.00	-11.19	peak	100	348
7	764.2899	1.43	26.20	27.63	37.00	-9.37	peak	100	0

Note: Measurement Level = Reading Level + Correct Factor





Test Mode :	Mode 10: Full system (HDMI mode 1920*1080@60Hz) Signal from PC (110V/60Hz)		
AC Power :	AC 110V/60Hz	Ant. Polarization:	Vertical
Equipment :	LCD Monitor	Model No :	215LM00071
Temperature :	23°C	Humidity :	56%
Pressure(mbar) :	1001	Date:	2017/05/07

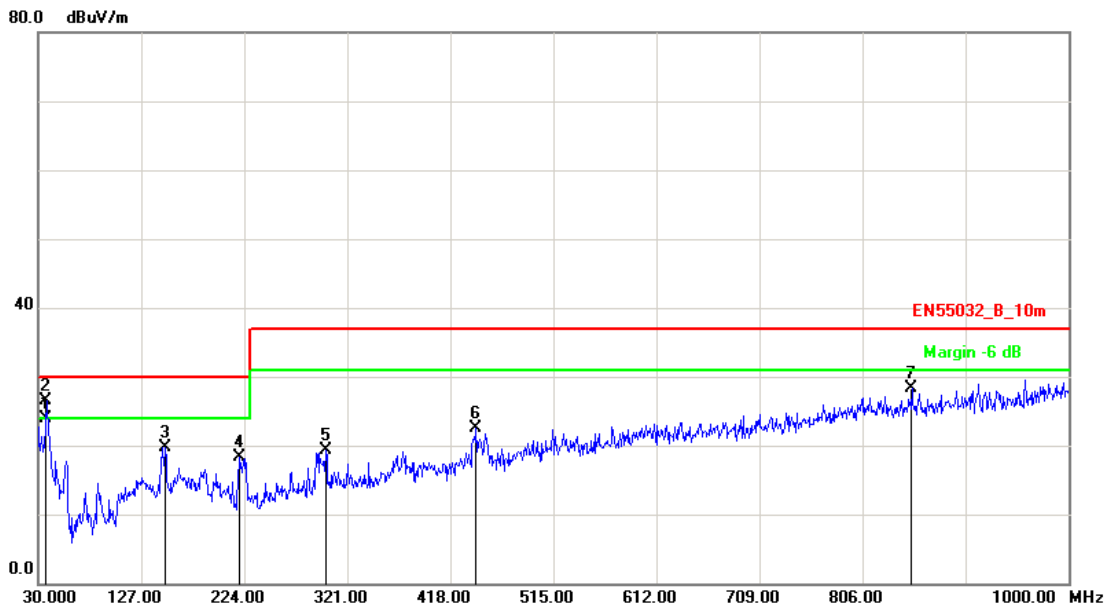

No.	Frequency (MHz)	Factor (dB/m)	Reading (dBuV)	Level (dBuV/m)	Limit (dBuV/m)	Margin (dB)	Det.	Height (cm)	Azimuth (deg)
1	36.9800	-8.30	32.14	23.84	30.00	-6.16	QP	400	53
2	37.7599	-8.86	35.27	26.41	30.00	-3.59	peak	400	217
3	149.3100	-10.62	30.41	19.79	30.00	-10.21	peak	100	0
4	219.1500	-11.84	30.06	18.22	30.00	-11.78	peak	400	229
5	300.6298	-8.74	28.10	19.36	37.00	-17.64	peak	100	354
6	442.2500	-4.74	27.28	22.54	37.00	-14.46	peak	400	0
7	852.5599	2.57	25.76	28.33	37.00	-8.67	peak	100	125

Note: Measurement Level = Reading Level + Correct Factor



### 5.6. Test Result and Data (1GHz~6GHz)

Test Mode :	Mode 1: Full system (VGA mode 1920*1080@60Hz) Signal from PC (230V/50Hz)		
AC Power :	AC 230V/50Hz	Ant. Polarization:	Horizontal
Equipment :	LCD Monitor	Model No :	215LM00071
Temperature :	23°C	Humidity :	56%
Pressure(mbar) :	1001	Date:	2017/05/07

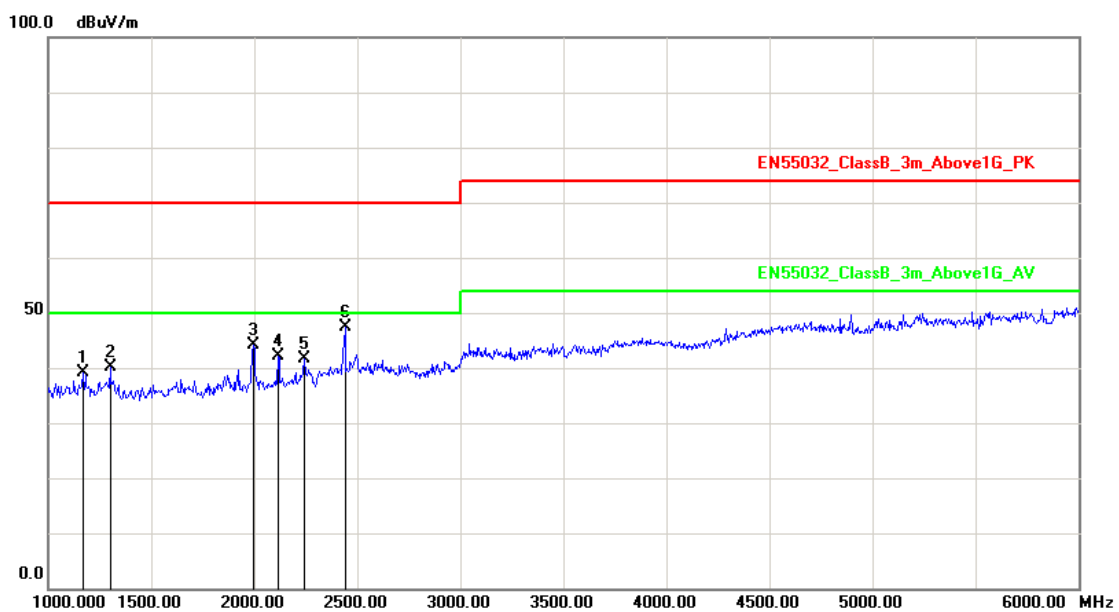

No.	Frequency (MHz)	Factor (dB/m)	Reading (dBuV)	Level (dBuV/m)	Limit (dBuV/m)	Margin (dB)	Det.	Height (cm)	Azimuth (deg)
1	1170.000	-4.84	43.92	39.08	70.00	-30.92	peak	100	335
2	1300.000	-3.98	44.15	40.17	70.00	-29.83	peak	200	335
3	1995.000	-1.21	45.31	44.10	70.00	-25.90	peak	100	0
4	2115.000	-0.61	42.83	42.22	70.00	-27.78	peak	200	298
5	2240.000	0.02	41.65	41.67	70.00	-28.33	peak	200	74
6	2440.000	1.04	46.22	47.26	70.00	-22.74	peak	200	113

Note: Measurement Level = Reading Level + Correct Factor



Test Mode :	Mode 1: Full system (VGA mode 1920*1080@60Hz) Signal from PC (230V/50Hz)		
AC Power :	AC 230V/50Hz	Ant. Polarization:	Vertical
Equipment :	LCD Monitor	Model No :	215LM00071
Temperature :	23°C	Humidity :	56%
Pressure(mbar) :	1001	Date:	2017/05/07

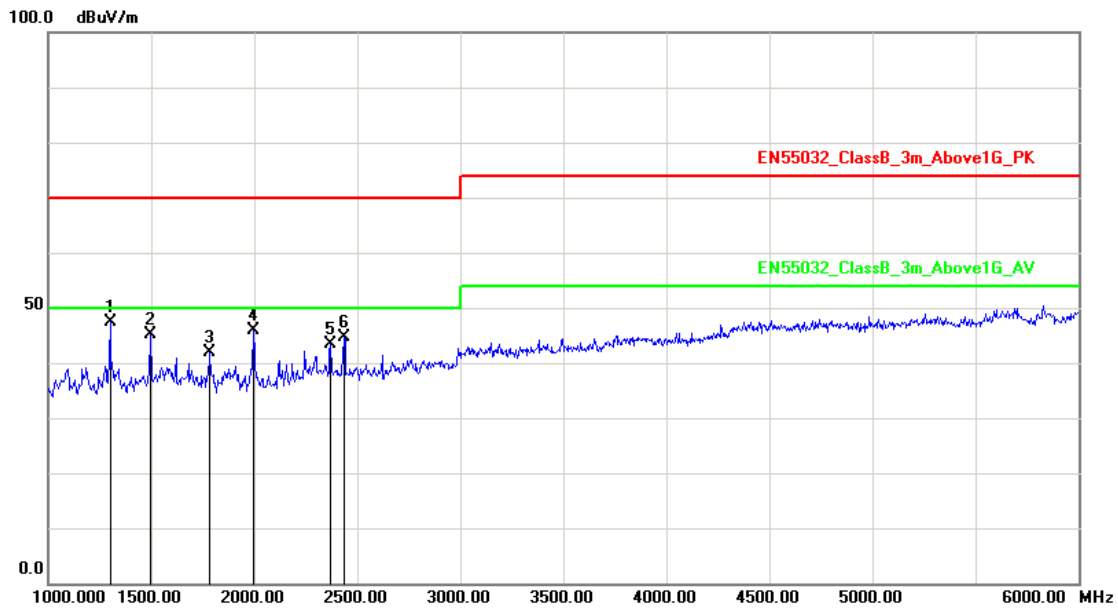

No.	Frequency (MHz)	Factor (dB/m)	Reading (dBuV)	Level (dBuV/m)	Limit (dBuV/m)	Margin (dB)	Det.	Height (cm)	Azimuth (deg)
1	1300.000	-3.98	51.32	47.34	70.00	-22.66	peak	100	286
2	1495.000	-2.67	47.86	45.19	70.00	-24.81	peak	200	0
3	1785.000	-1.82	43.70	41.88	70.00	-28.12	peak	200	132
4	1995.000	-1.21	47.05	45.84	70.00	-24.16	peak	100	117
5	2370.000	0.69	42.73	43.42	70.00	-26.58	peak	100	0
6	2435.000	1.02	43.51	44.53	70.00	-25.47	peak	100	54

Note: Measurement Level = Reading Level + Correct Factor



Test Mode :	Mode 4: Full system (HDMI mode 1920*1080@60Hz) Signal from PC(230V/50Hz)		
AC Power :	AC 230V/50Hz	Ant. Polarization:	Horizontal
Equipment :	LCD Monitor	Model No :	215LM00071
Temperature :	23°C	Humidity :	56%
Pressure(mbar) :	1001	Date:	2017/05/07

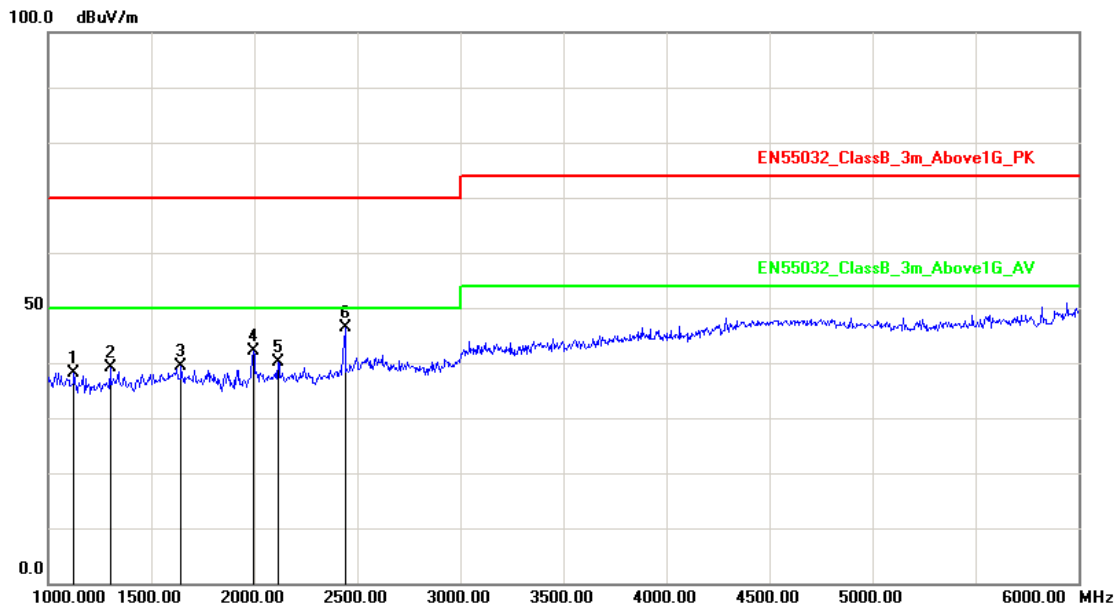

No.	Frequency (MHz)	Factor (dB/m)	Reading (dBuV)	Level (dBuV/m)	Limit (dBuV/m)	Margin (dB)	Det.	Height (cm)	Azimuth (deg)
1	1125.000	-5.15	43.24	38.09	70.00	-31.91	peak	200	175
2	1300.000	-3.98	43.15	39.17	70.00	-30.83	peak	119	326
3	1645.000	-2.22	41.64	39.42	70.00	-30.58	peak	100	0
4	1995.000	-1.21	43.31	42.10	70.00	-27.90	peak	100	91
5	2115.000	-0.61	40.83	40.22	70.00	-29.78	peak	200	0
6	2440.000	1.04	45.22	46.26	70.00	-23.74	peak	200	0

Note: Measurement Level = Reading Level + Correct Factor



Test Mode :	Mode 4: Full system (HDMI mode 1920*1080@60Hz) Signal from PC(230V/50Hz)		
AC Power :	AC 230V/50Hz	Ant. Polarization:	Vertical
Equipment :	LCD Monitor	Model No :	215LM00071
Temperature :	23°C	Humidity :	56%
Pressure(mbar) :	1001	Date:	2017/05/07

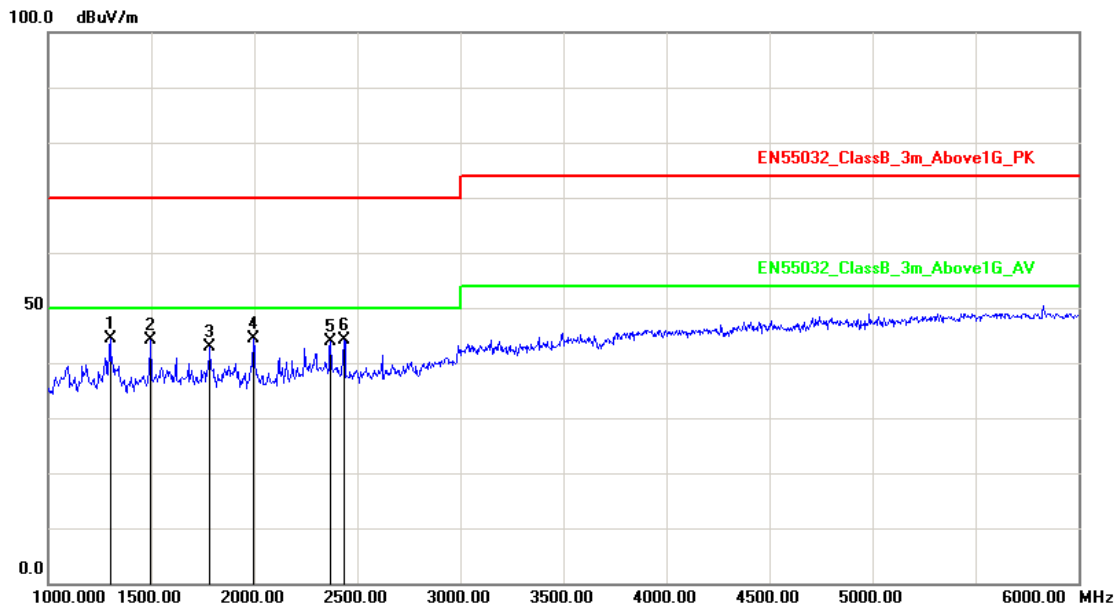

No.	Frequency (MHz)	Factor (dB/m)	Reading (dBuV)	Level (dBuV/m)	Limit (dBuV/m)	Margin (dB)	Det.	Height (cm)	Azimuth (deg)
1	1300.000	-3.98	48.32	44.34	70.00	-25.66	peak	161	0
2	1495.000	-2.67	46.86	44.19	70.00	-25.81	peak	128	156
3	1785.000	-1.82	44.70	42.88	70.00	-27.12	peak	100	247
4	1995.000	-1.21	45.55	44.34	70.00	-25.66	peak	100	118
5	2370.000	0.69	43.23	43.92	70.00	-26.08	peak	148	216
6	2435.000	1.02	43.01	44.03	70.00	-25.97	peak	100	3

Note: Measurement Level = Reading Level + Correct Factor



Test Mode :	Mode 9: Full system (VGA mode 1920*1080@60Hz) Signal from PC (110V/60Hz)		
AC Power :	AC 110V/60Hz	Ant. Polarization:	Horizontal
Equipment :	LCD Monitor	Model No :	215LM00071
Temperature :	23°C	Humidity :	56%
Pressure(mbar) :	1001	Date:	2017/05/07

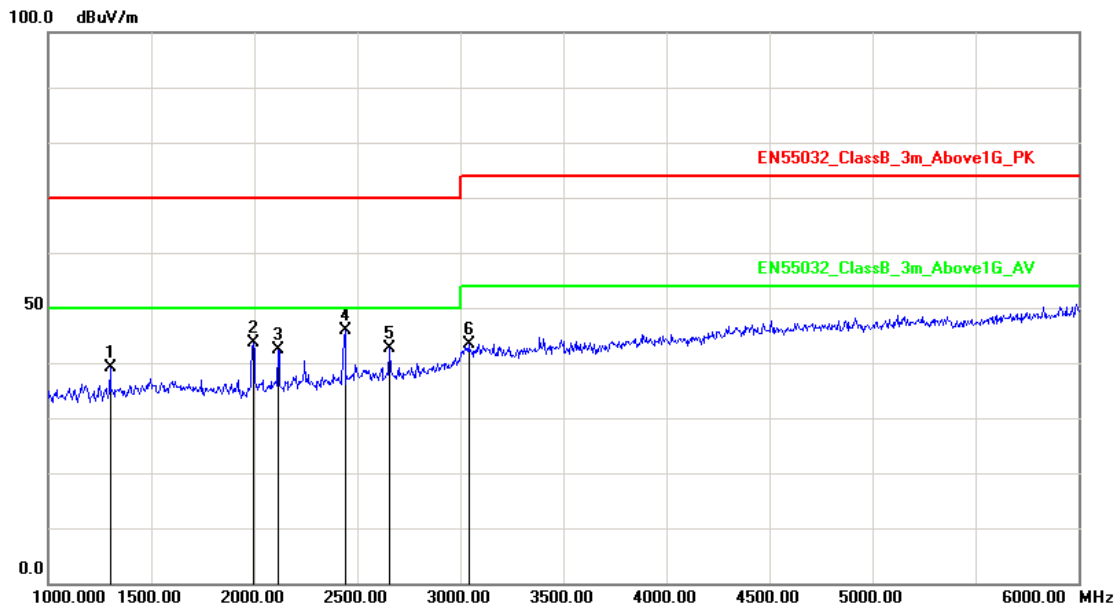

No.	Frequency (MHz)	Factor (dB/m)	Reading (dBuV)	Level (dBuV/m)	Limit (dBuV/m)	Margin (dB)	Det.	Height (cm)	Azimuth (deg)
1	1300.000	-3.98	43.08	39.10	70.00	-30.90	peak	130	360
2	1995.000	-1.21	44.89	43.68	70.00	-26.32	peak	100	0
3	2115.000	-0.61	42.95	42.34	70.00	-27.66	peak	200	311
4	2440.000	1.04	44.73	45.77	70.00	-24.23	peak	100	22
5	2655.000	2.21	40.48	42.69	70.00	-27.31	peak	194	360
6	3040.000	4.24	39.21	43.45	74.00	-30.55	peak	100	0

Note: Measurement Level = Reading Level + Correct Factor



Test Mode :	Mode 9: Full system (VGA mode 1920*1080@60Hz) Signal from PC (110V/60Hz)		
AC Power :	AC 110V/60Hz	Ant. Polarization:	Vertical
Equipment :	LCD Monitor	Model No :	215LM00071
Temperature :	23°C	Humidity :	56%
Pressure(mbar) :	1001	Date:	2017/05/07

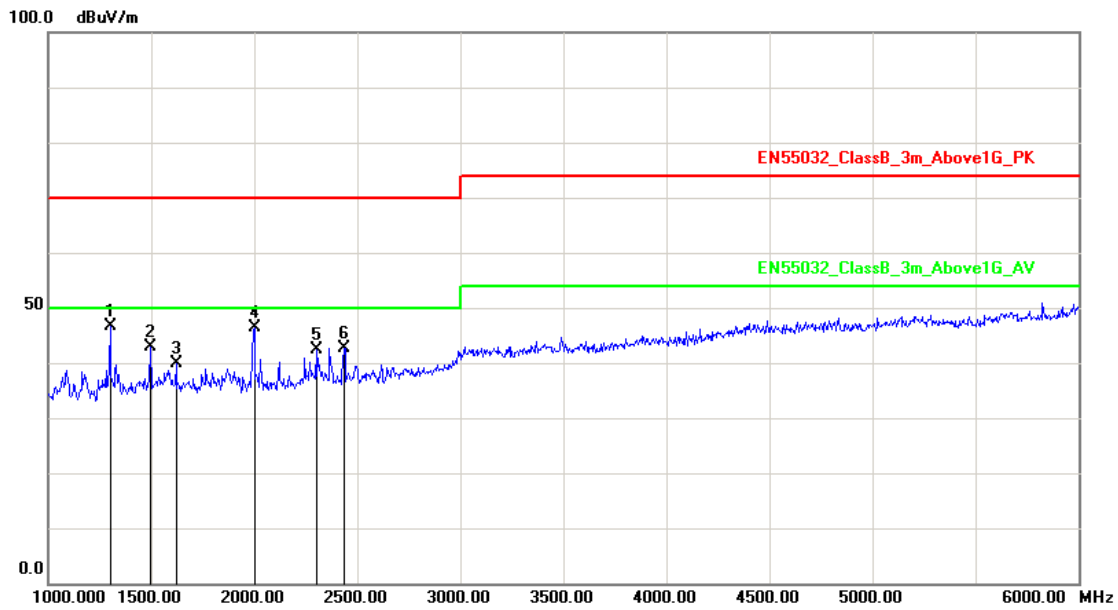

No.	Frequency (MHz)	Factor (dB/m)	Reading (dBuV)	Level (dBuV/m)	Limit (dBuV/m)	Margin (dB)	Det.	Height (cm)	Azimuth (deg)
1	1300.000	-3.98	50.49	46.51	70.00	-23.49	peak	100	360
2	1495.000	-2.67	45.46	42.79	70.00	-27.21	peak	200	0
3	1620.000	-2.29	42.21	39.92	70.00	-30.08	peak	100	342
4	2000.000	-1.20	47.46	46.26	70.00	-23.74	peak	200	297
5	2300.000	0.33	42.16	42.49	70.00	-27.51	peak	150	360
6	2435.000	1.02	41.72	42.74	70.00	-27.26	peak	200	314

Note: Measurement Level = Reading Level + Correct Factor



Test Mode :	Mode 10: Full system (HDMI mode 1920*1080@60Hz) Signal from PC (110V/60Hz)		
AC Power :	AC 110V/60Hz	Ant. Polarization:	Horizontal
Equipment :	LCD Monitor	Model No :	215LM00071
Temperature :	23°C	Humidity :	56%
Pressure(mbar) :	1001	Date:	2017/05/07

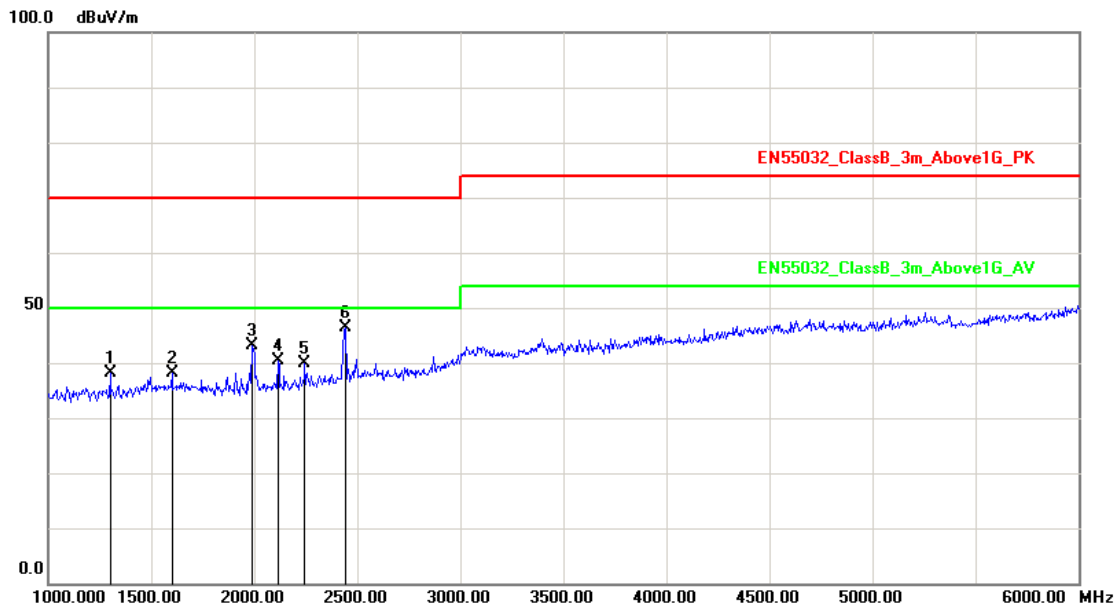

No.	Frequency (MHz)	Factor (dB/m)	Reading (dBuV)	Level (dBuV/m)	Limit (dBuV/m)	Margin (dB)	Det.	Height (cm)	Azimuth (deg)
1	1300.000	-3.98	42.23	38.25	70.00	-31.75	peak	123	360
2	1600.000	-2.35	40.43	38.08	70.00	-31.92	peak	200	98
3	1990.000	-1.23	44.25	43.02	70.00	-26.98	peak	200	83
4	2115.000	-0.61	41.00	40.39	70.00	-29.61	peak	200	322
5	2245.000	0.05	39.75	39.80	70.00	-30.20	peak	200	360
6	2445.000	1.07	45.34	46.41	70.00	-23.59	peak	144	360

Note: Measurement Level = Reading Level + Correct Factor





Test Mode :	Mode 10: Full system (HDMI mode 1920*1080@60Hz) Signal from PC (110V/60Hz)		
AC Power :	AC 110V/60Hz	Ant. Polarization:	Vertical
Equipment :	LCD Monitor	Model No :	215LM00071
Temperature :	23°C	Humidity :	56%
Pressure(mbar) :	1001	Date:	2017/05/07

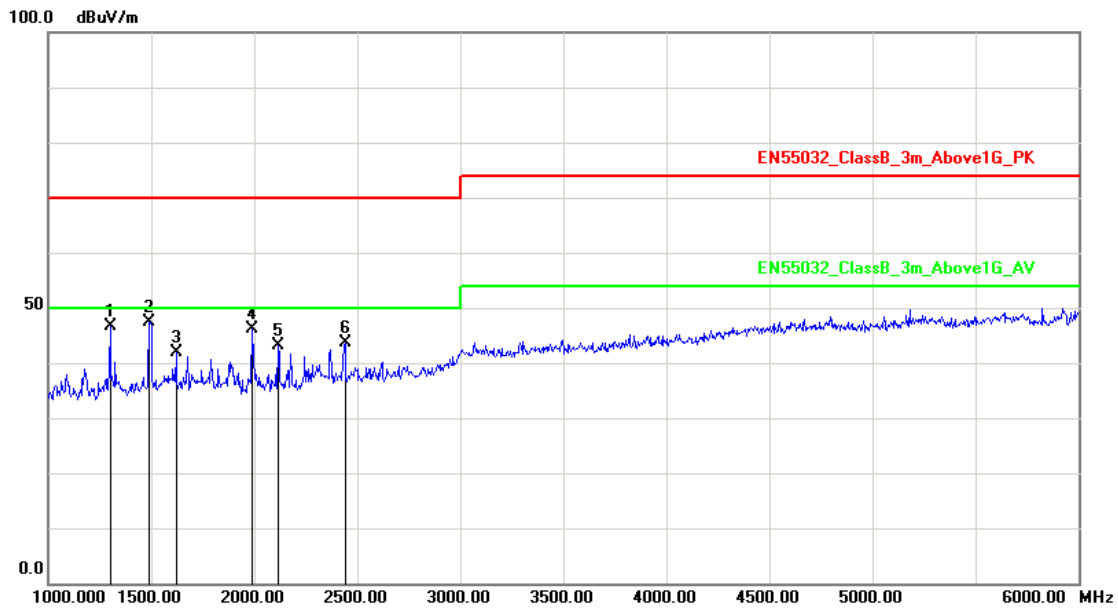

No.	Frequency (MHz)	Factor (dB/m)	Reading (dBuV)	Level (dBuV/m)	Limit (dBuV/m)	Margin (dB)	Det.	Height (cm)	Azimuth (deg)
1	1300.000	-3.98	50.56	46.58	70.00	-23.42	peak	100	338
2	1490.000	-2.71	50.16	47.45	70.00	-22.55	peak	168	360
3	1620.000	-2.29	44.23	41.94	70.00	-28.06	peak	198	360
4	1990.000	-1.23	47.29	46.06	70.00	-23.94	peak	200	317
5	2115.000	-0.61	43.86	43.25	70.00	-26.75	peak	100	36
6	2440.000	1.04	42.64	43.68	70.00	-26.32	peak	200	288

Note: Measurement Level = Reading Level + Correct Factor

Test engineer: Sun. Zhang



### 5.7. Test Photographs (30MHz~1GHz)

Front View

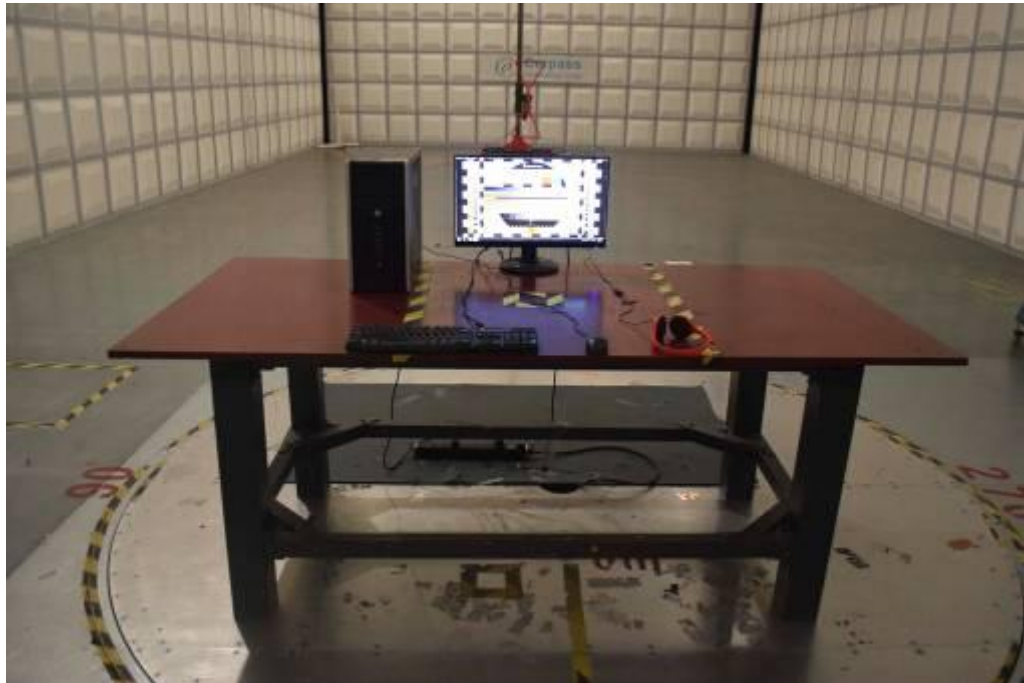

Rear View

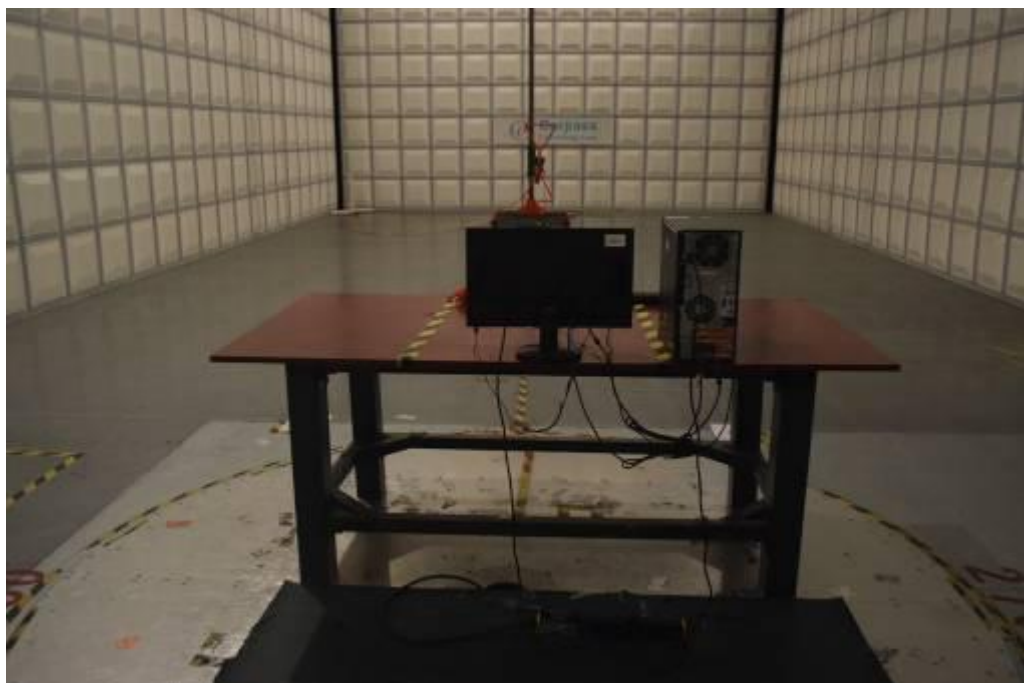



### 5.8. Test Photographs (1GHz~6GHz)

Front View

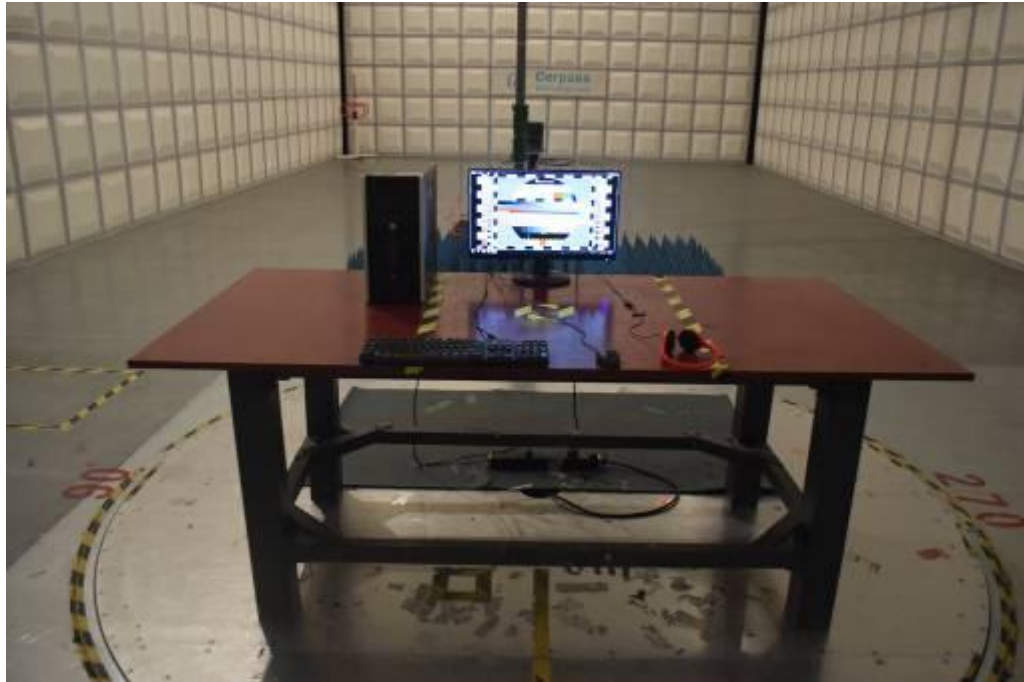

Rear View

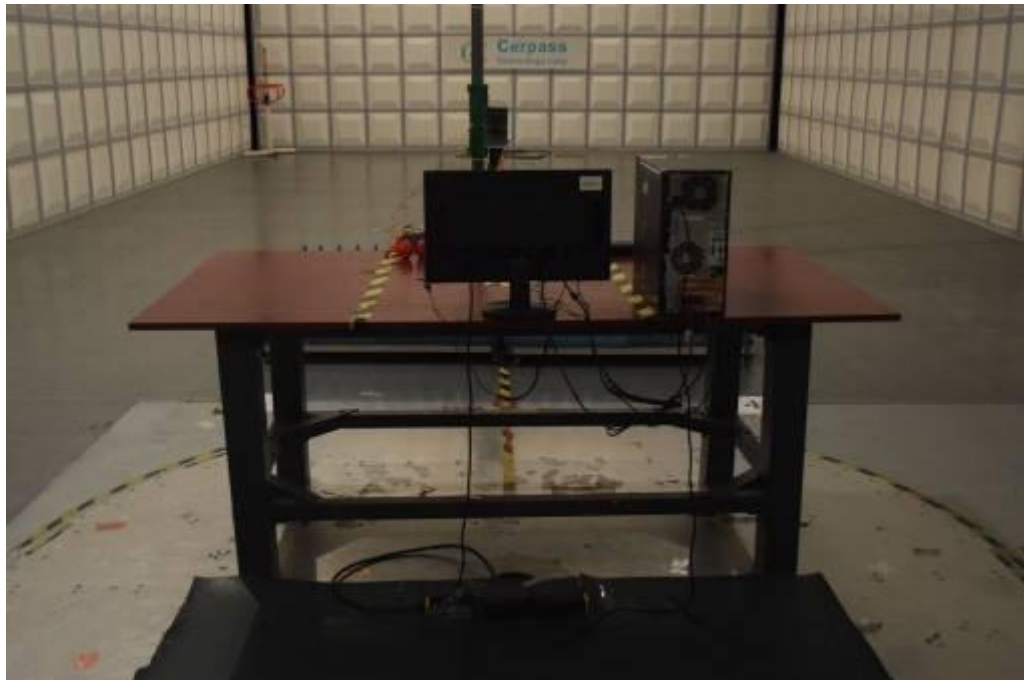



## 6. Harmonics Test

### 6.1. Limits of Harmonics Current Measurement

#### Limits for Class A equipment

Harmonics Order n	Max. permissible harmonics current A	Harmonics Order n	Max. permissible harmonics current A
Odd harmonics		Even harmonics	
3	2.30	2	1.08
5	1.14	4	0.43
7	0.77	6	0.30
9	0.40	8 ≤ n ≤ 40	0.23x8/n
11	0.33		
13	0.21		
15 ≤ n ≤ 39	0.15x15/n		

#### (b) Limits for Class B equipment

For Class B equipment, the harmonics of the input current shall not exceed the values given in Table that is the limit of Class A multiplied by a factor of 1,5.

#### (c) Limits for Class C equipment

Harmonics Order n	Maximum permissible harmonic current expressed as a percentage of the input current at the fundamental frequency %
2	2
3	$30 \cdot \lambda^*$
5	10
7	7
9	5
11 < n < 39 (odd harmonics only)	3

\*  $\lambda$  is the circuit power factor

#### (d) Limits for Class D equipment

Harmonics Order n	Maximum permissible harmonic current per watt mA/W	Maximum permissible harmonic current A
3	3.4	2.30
5	1.9	1.14
7	1.0	0.77
9	0.5	0.40
11	0.35	0.33
11 < n < 39 (odd harmonics only)	3.85/n	See limit of Class A

**NOTE:** According to section 7 of EN 61000-3-2, the above limits for all equipment except for lighting equipment having an active input power > 75 W and no limits apply for equipment with an active input power up to and including 75 W.



### 6.2. Measurement Equipment

Instrument/Ancillary	Manufacturer	Model No.	Serial No.	Calibration Date	Valid Date.
EMC Emission Tester	EMCPARTNER	Harmonics-1000	159	2017.03.28	2018.03.27
Temperature/ Humidity Meter	Zhicheng	ZC1-11	CEP-TH-004	2017.03.28	2018.03.27
HARCS	EMC Partner AG	Ver 4.18	N/A	N/A	N/A



### 6.3. Test Result and Data

Basic Standard	:	EN 61000-3-2
Final Test Result	:	PASS
Test Mode	:	Mode 1,4
Model No.	:	215LM00071
Temperature	:	24°C
Humidity	:	52 %
Atmospheric Pressure	:	100 kPa
Test Date	:	May 07, 2017

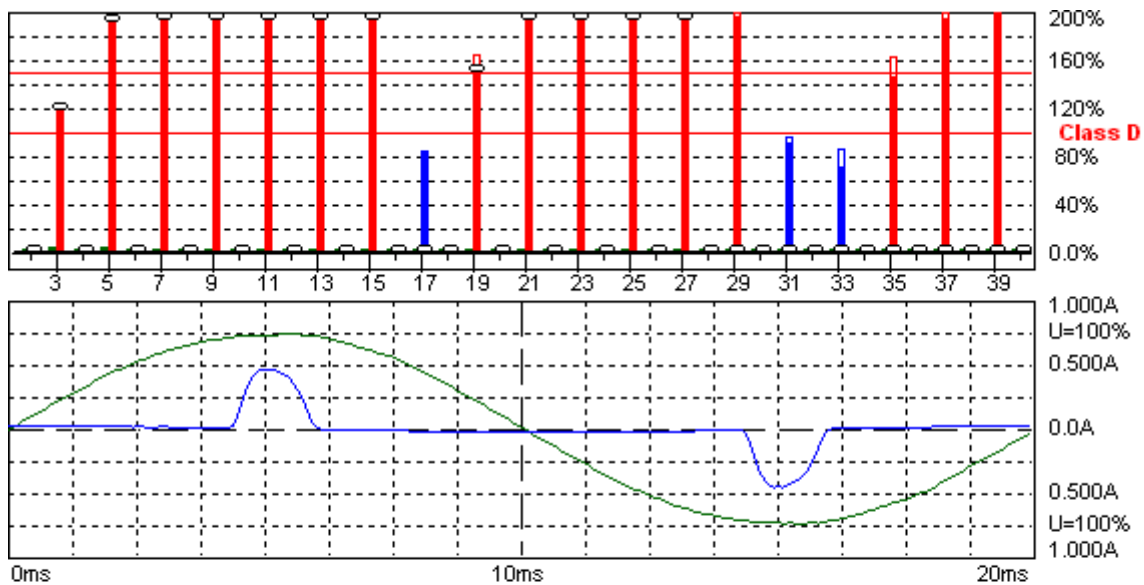

Harmonic Emission - IEC 61000-3-2 , EN 61000-3-2 , (EN60555-2)

2017-5-7 11:39:41 harmonic.hsu

Urms = 230.5 V	P = 16.62 W	THC = 0.121 A	Range: 1 A
Irms = 0.140 A	pf = 0.514	Pmax = 16.76 W	V-nom: 230 V
			TestTime: 15 min (100%)

HAR-1000 EMC-Parber

Urms = 230.5V Freq = 49.987 Range: 1 A  
 Irms = 0.140A Ipk = 0.469A cf = 3.348  
 P = 16.62W S = 32.30VA pf = 0.514  
 THDi = 85.2 % THDu = 1.40 % Class D  
 Test - Time : 15min ( 100 %)  
 Limit Reference: Pmax = 16.759W  
 Test completed



Order	Freq. [Hz]	Irms [A]	Irms%L [%]	I <sub>max</sub> [A]	I <sub>max</sub> %L [%]	Limit [A]	Status
1	50	0.0748		0.0751			
2	100	0.0017		0.0018			
3	150	0.0679	119.22	0.0682	119.75	0.00	N/L
4	200	0.0017		0.0018			
5	250	0.0615	193.21	0.0616	193.60	0.00	N/L
6	300	0.0017		0.0018			
7	350	0.0527	314.29	0.0527	314.66	0.00	N/L
8	400	0.0014		0.0015			
9	450	0.0424	506.22	0.0425	507.68	0.00	N/L
10	500	0.0013		0.0013			
11	550	0.0307	523.39	0.0309	526.51	0.00	N/L
12	600	0.0010		0.0011			
13	650	0.0193	388.59	0.0195	392.28	0.00	N/L
14	700	0.0006		0.0007			
15	750	0.0099	229.86	0.0101	234.12	0.00	N/L
16	800	0.0004		0.0004			
17	850	0.0031	80.405	0.0031	82.013	0.00	N/L
18	900	0.0002		0.0003			
19	950	0.0051	150.97	0.0056	163.55	0.00	N/L
20	1000	0.0004		0.0005			
21	1050	0.0081	262.22	0.0084	272.15	0.00	N/L
22	1100	0.0006		0.0007			
23	1150	0.0092	326.35	0.0092	328.53	0.00	N/L
24	1200	0.0006		0.0007			
25	1250	0.0085	331.08	0.0086	333.45	0.00	N/L
26	1300	0.0006		0.0007			
27	1350	0.0067	280.95	0.0068	286.05	0.00	N/L
28	1400	0.0004		0.0005			
29	1450	0.0043	192.03	0.0044	197.51	0.00	N/L
30	1500	0.0002		0.0002			
31	1550	0.0018	87.973	0.0020	93.838	0.00	N/L
32	1600	0.0002		0.0002			
33	1650	0.0013	68.676	0.0016	84.284	0.00	N/L
34	1700	0.0002		0.0002			
35	1750	0.0026	142.36	0.0029	158.92	0.00	N/L
36	1800	0.0003		0.0004			
37	1850	0.0034	196.00	0.0035	203.00	0.00	N/L
38	1900	0.0004		0.0004			
39	1950	0.0035	210.28	0.0035	213.97	0.00	N/L
40	2000	0.0004		0.0004			
39	1950	0.0122	432.45	0.0183	648.67	0.00	N/L
40	2000	0.0153		0.0183			

The power of EUT is less than 75W after the testing. According the standard, the equipment with a rated power of 75W or less, other than lighting equipment, limits are not specified in this standard. So the test data needn't list.

Test engineer: Sun. Zhang





#### 6.4. Test Photographs

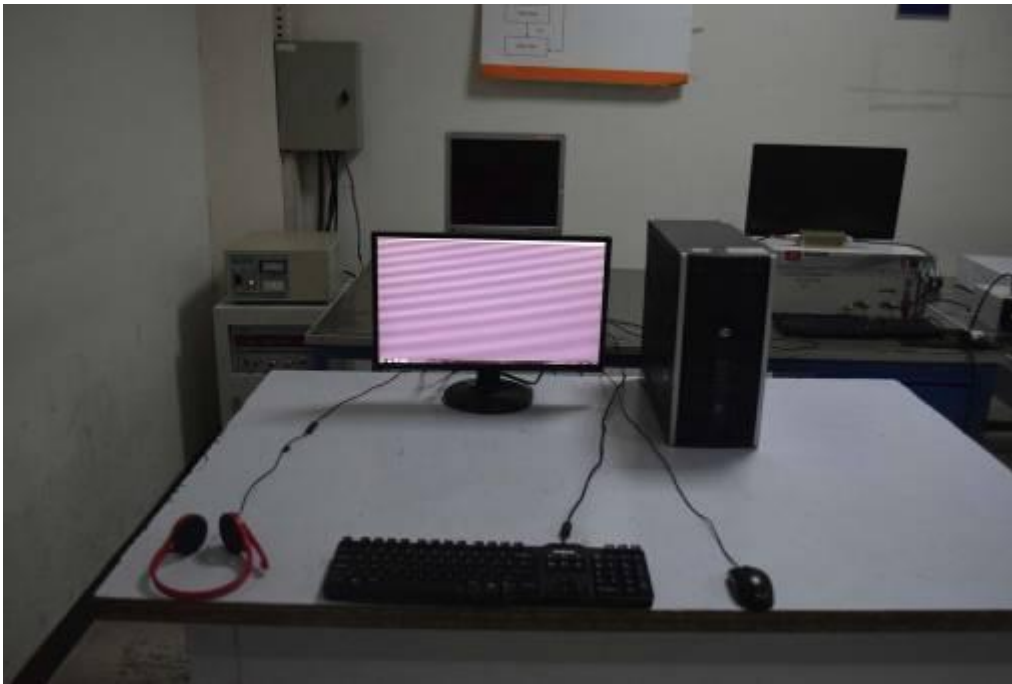





## 7. Voltage Fluctuations Test

### 7.1. Test Procedure

The equipment shall be tested under the conditions of **Clause 5**.

The total impedance of the test circuit, excluding the appliance under test, but including the internal impedance of the supply source, shall be equal to the reference impedance.

The stability and tolerance of the reference impedance shall be adequate to ensure that the overall accuracy of  $\pm 8\%$  is achieved during the whole assessment procedure.

### 7.2. Measurement Equipment

Instrument/Ancillary	Manufacturer	Model No.	Serial No.	Calibration Date	Valid Date.
EMC Emission Tester	EMCPARTNER	Harmonics-1000	159	2017.03.28	2018.03.27
Temperature/ Humidity Meter	Zhicheng	ZC1-11	CEP-TH-004	2017.03.28	2018.03.27
HARCS	EMC Partner AG	Ver 4.18	N/A	N/A	N/A



7.3. Test Result and Data

Basic Standard	:	EN 61000-3-3
Final Test Result	:	PASS
Test Mode	:	Mode 1,4
Model No.	:	215LM00071
Temperature	:	24°C
Humidity	:	52 %
Atmospheric Pressure	:	100 kPa
Test Date	:	May 07, 2017

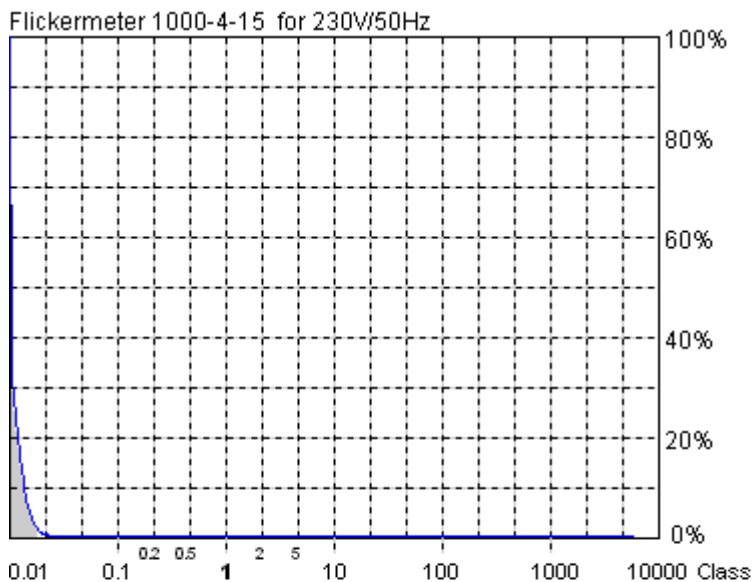

**Actual Flicker (Fli): 0.01**  
**Short-term Flicker (Pst): 0.08**  
 Limit (Pst): 1.00  
**Long-term Flicker (Plt): 0.08**  
 Limit (Plt): 0.65  
**Maximum Relative Volt. Change (dmax): 0.00%**  
 Limit (dmax): 4.00%  
**Relative Steady-state Voltage Change (dc): 0.13%**  
 Limit (dc): 3.30%  
**Maximum Interval exceeding 3.30% (dt): 0.00ms**  
 Limit (dt>Lim): 500ms

Flicker Emission - IEC 61000-3-3 , EN 61000-3-3 , (EN60555-3)

2017-5-7 11:52:54 harmonic.hsu

Urms = 230.5 V P = 16.69 W  
 Irms = 0.141 A pf = 0.513

Range: 1 A  
 V-nom: 230 V  
 TestTime: 10 min (100%)

Test completed, Result: PASSED

HAR-1000 EMC-Partner

- Full Bar : Actual Values
- Empty Bar : Maximum Values
- Circles : Average Values
- Blue : Current , Green : Voltage , Red : Failed



Urms = 230.5V Freq = 50.013 Range: 1 A  
Irms = 0.141A Ipk = 0.472A cf = 3.346  
P = 16.69W S = 32.53VA pf = 0.513

Test - Time : 1 x 10min = 10min ( 100 %)

LIN (Line Impedance Network) : No LIN

Limits : Plt : 0.65 Pst : 1.00  
dmax : 4.00 % dc : 3.30 %  
dtLim: 3.30 % dt>Lim: 500ms

Test completed, Result: PASSED

Test engineer: Sun. Zhang



#### 7.4. Test Photographs

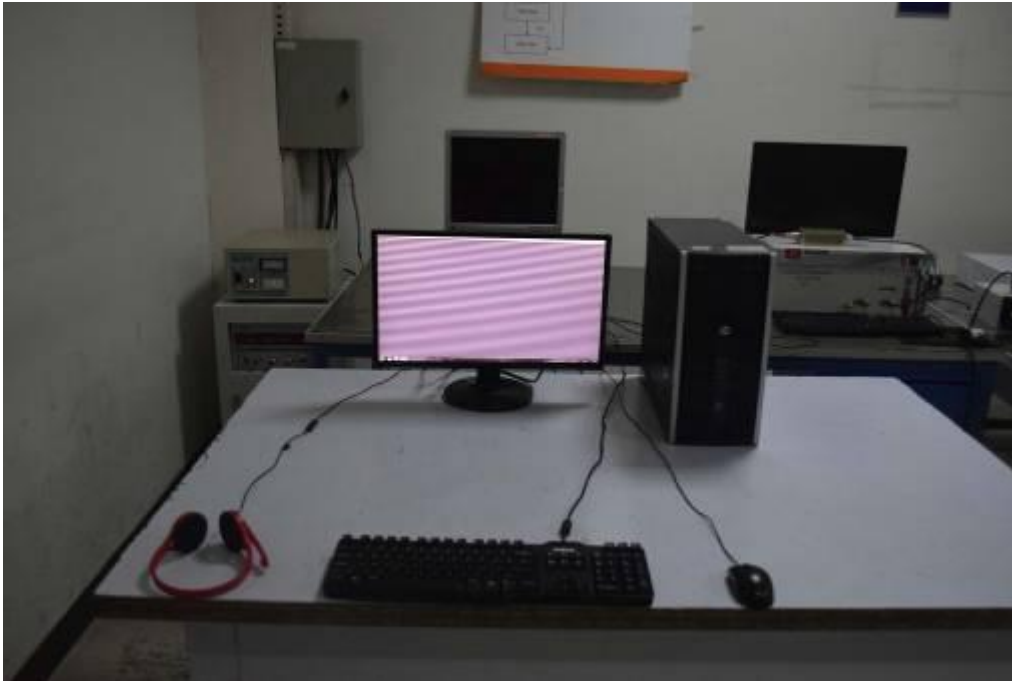



## 8. Electrostatic Discharge Immunity Test

### 8.1. Test Procedure

- a. In the case of air discharge testing the climatic conditions shall be within the following ranges:
  - ambient temperature: 15°C to 35°C;
  - relative humidity : 30% to 60%;
  - atmospheric pressure : 86 KPa (860 mbar) to 106 KPa (1060 mbar).
- b. Test programs and software shall be chosen so as to exercise all normal modes of operation of the EUT. The use of special exercising software is encouraged, but permitted only where it can be shown that the EUT is being comprehensively exercised.
- c. The test voltage shall be increased from the minimum to the selected test severity level, in order to determine any threshold of failure. The final severity level should not exceed the product specification value in order to avoid damage to the equipment.
- d. The test shall be performed with both air discharge and contact discharge. On reselected points at least 10 single discharges (in the most sensitive polarity) shall be applied on air discharge. On reselected points at least 25 single discharges (in the most sensitive polarity) shall be applied on contact discharge.
- e. For the time interval between successive single discharges an initial value of one second is recommended. Longer intervals may be necessary to determine whether a system failure has occurred.
- f. In the case of contact discharges, the tip of the discharge electrode shall touch the EUT before the discharge switch is operated.
- g. In the case of painted surface covering a conducting substrate, the following procedure shall be adopted :
  - If the coating is not declared to be an insulating coating by the equipment manufacturer, then the pointed tip of the generator shall penetrate the coating so as to make contact with the conducting substrate.
  - Coating declared as insulating by the manufacturer shall only be submitted to the air discharge.
  - The contact discharge test shall not be applied to such surfaces.
- h. In the case of air discharges, the round discharge tip of the discharge electrode shall be approached as fast as possible (without causing mechanical damage) to touch the EUT . After each discharge, the ESD generator (discharge electrode) shall be removed from the EUT. The generator is then retriggered for a new single discharge. This procedure shall be repeated until the discharges are completed. In the case of an air discharge test, the discharge switch, which is used for contact discharge, shall be closed.

## 8.2. Test Setup for Tests Performed in Laboratory

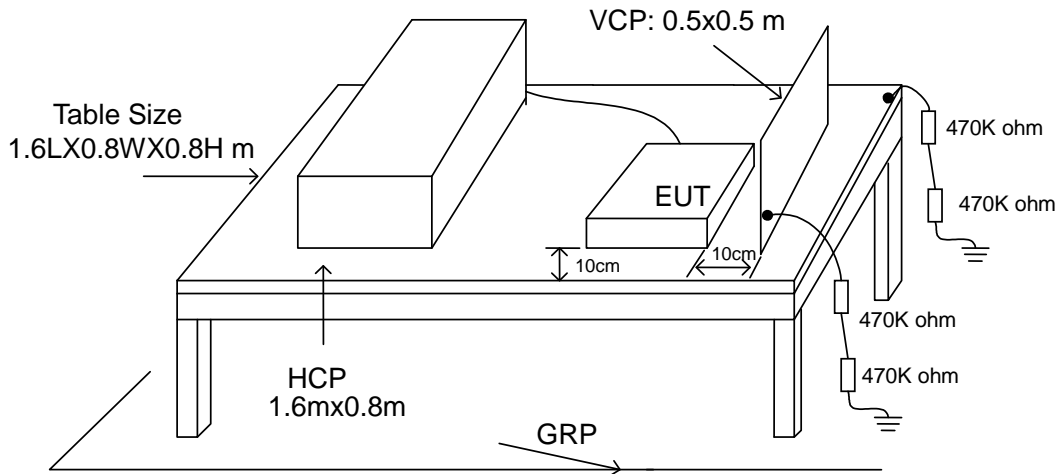

The test setup consists of the test generator, EUT and auxiliary instrumentation necessary to perform DIRECT and INDIRECT application of discharges to the EUT as applicable, in the follow manner :

- b. Contact Discharge to the conductive surfaces and to coupling plane;
- c. Air Discharge at insulating surfaces.

The preferred test method is that of type tests performed in laboratories and the only accepted method of demonstrating conformance with this standard. The EUT was arranged as closely as possible to arrangement in final installed conditions.

A ground reference plane was provided on the floor of the test site. It was a metallic sheet (copper or aluminum) of 0.25 mm, minimum thickness; other metallic may be used but they shall have at least 0.65 mm thickness. In the CerpPASS Technology Corp., we provided 1 mm thickness stainless steel ground reference plane. The minimum size of the ground reference plane is 2.5 m x 2.5 m, the exact size depending on the dimensions of the EUT. It was connected to the protective grounding system.

The EUT was arranged and connected according to its functional requirements. A distance of 1m minimum was provided between the EUT and the wall of the lab. and any other metallic structure. In cases where this length exceeds the length necessary to apply the discharges to the selected points, the excess length shall, where possible, be placed non-inductively off the ground reference plane and shall not come closer than 0.2m to other conductive parts in the test setup.

Where the EUT is installed on a metal table, the table was connected to the reference plane via a cable with a 470k ohm resistor located at each end, to prevent a build-up of charge. The test setup was consist a wooden table, 0.8m high, standing on the ground reference plane. A HCP, 1.6 m x 0.8 m, was placed on the table. The EUT and cables was isolated from the HCP by an insulating support 0.5 mm thick. The VCP size, 0.5 m x 0.5 m.



### 8.3. Test Severity Levels

Contact Discharge		Air Discharge	
Level	Test Voltage (KV) of Contact discharge	Level	Test Voltage (KV) of Air Discharge
1	±2	1	±2
2	±4	2	±4
3	±6	3	±8
4	±8	4	±15
X	Specified	X	Specified
Remark: "X" is an open level.			

### 8.4. Measurement Equipment

Instrument/Ancillary	Manufacturer	Model No.	Serial No.	Calibration Date	Valid Date.
ESD Simulator	EM Test	Dito	P1645186902	2017.02.16	2018.02.15
Tonometer	shanghaifengyun	DYM3	3251	2016.12.21	2017.12.20
Dehumidifier	ZEDO	ZD-220LB	CEP-TH-01	N/A	N/A
Humidifier	YADU	YZ-DS251C	CEP-TH-02	N/A	N/A
Temperature/ Humidity Meter	feiyang	N/A	102	2017.03.28	2018.03.27
ESD Simulator	NoiseKen	ESS-B3011A	AEC00315-00 C-0A	2016.12.12	2017.12.11



8.5. Test Result and Data

Final Test Result : **PASS**  
 Pass performance criteria : B  
 Basic Standard : IEC 61000-4-2  
 Model No. : 215LM00071  
 Test Voltage : ±2 / ±4 / ±8 KV for air discharge,  
 ±2 / ±4 KV for contact discharge  
 Temperature : 23 °C  
 Relative Humidity : 49 %  
 Atmospheric Pressure : 100 kPa  
 Test Date : May 07, 2017

Test Mode : Mode 1,4

	Contact Discharge								Air Discharge							
	25 times / each								10 times / each							
Voltage	2 kV		4 kV		6 kV		8 kV		2 kV		4 kV		8 kV		10 kV	
HCP	A	A	A	A	---	---	---	---	---	---	---	---	---	---	---	---
VCP	A	A	A	A	---	---	---	---	---	---	---	---	---	---	---	---
Screw	A	A	A	A	---	---	---	---	---	---	---	---	---	---	---	---
Case	---	---	---	---	---	---	---	---	A	A	A	A	A	A	---	---
Panel	---	---	---	---	---	---	---	---	A	A	A	A	A	A	---	---
HDMI Port	A	A	A	A	---	---	---	---	---	---	---	---	---	---	---	---
VGA Port	A	A	A	A	---	---	---	---	---	---	---	---	---	---	---	---
Audio Port	---	---	---	---	---	---	---	---	A	A	A	A	A	A	---	---
Power Port	---	---	---	---	---	---	---	---	A	A	A	A	A	A	---	---
Button	---	---	---	---	---	---	---	---	A	A	A	A	A	A	---	---
LED Light	---	---	---	---	---	---	---	---	A	A	A	A	A	A	---	---

Test engineer: Sun. Zhang





### 8.6. Test Photographs

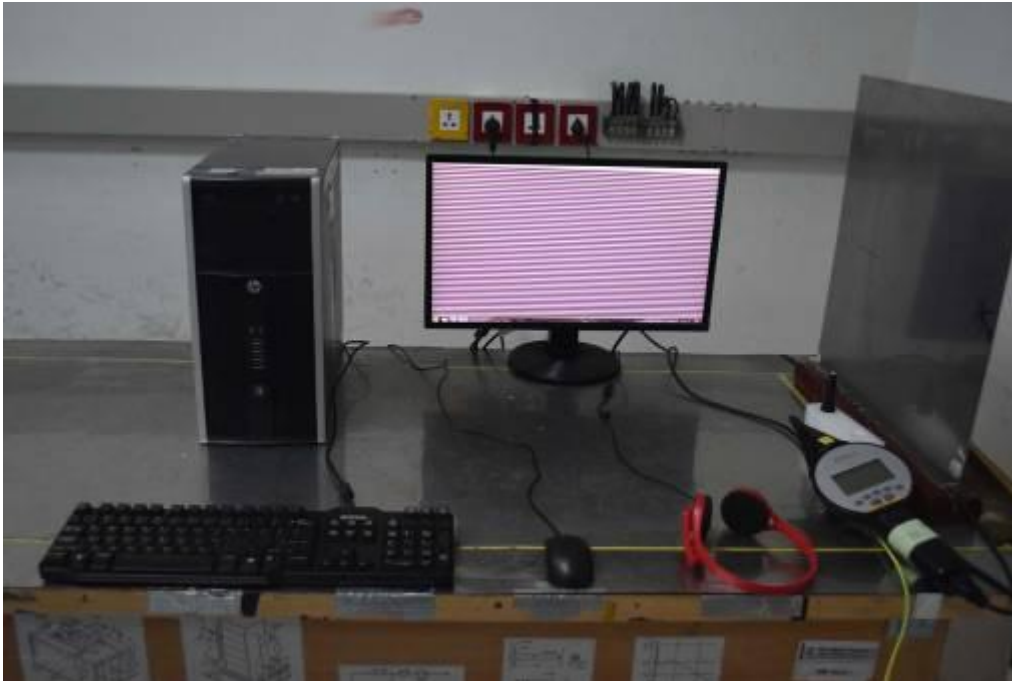



## 9. Radio Frequency electromagnetic field immunity test

### 9.1. Test Procedure

- a. The equipment to be tested is placed in the center of the enclosure on a wooden table. The equipment is then connected to power and signal leads according to pertinent installation instructions.
- b. The antenna which is enabling the complete frequency range of 80-1000 MHz is placed 3m away from the equipment. The required field strength is determined by placing the field strength meter(s) on top of or directly alongside the equipment under test and monitoring the field strength meter via a remote field strength indicator outside the enclosure while adjusting the continuous-wave to the applicable antennae.
- c. The test is normally performed with the antenna facing the most sensitive side of the EUT. The polarization of the field generated by the bucolical antenna necessitates testing each position twice, once with the antenna positioned vertically and again with the antenna positioned horizontally. The circular polarization of the field from the log-spiral antenna makes a change of position of the antenna unnecessary.
- d. At each of the above conditions, the frequency range is swept 80-1000 MHz, pausing to adjust the R.F. signal level or to switch oscillators and antenna. The rate of sweep is in the order of  $1.5 \times 10^{-3}$  decades/s. The sensitive frequencies or frequencies of dominant interest may be discretely analyzed.

### 9.2. Test Severity Levels

Frequency Band : 80-1000 MHz	
Level	Test field strength (V/m)
1	1
2	3
3	10
X	Specified
Remark: "X" is an open class.	

### 9.3. TEST SETUP

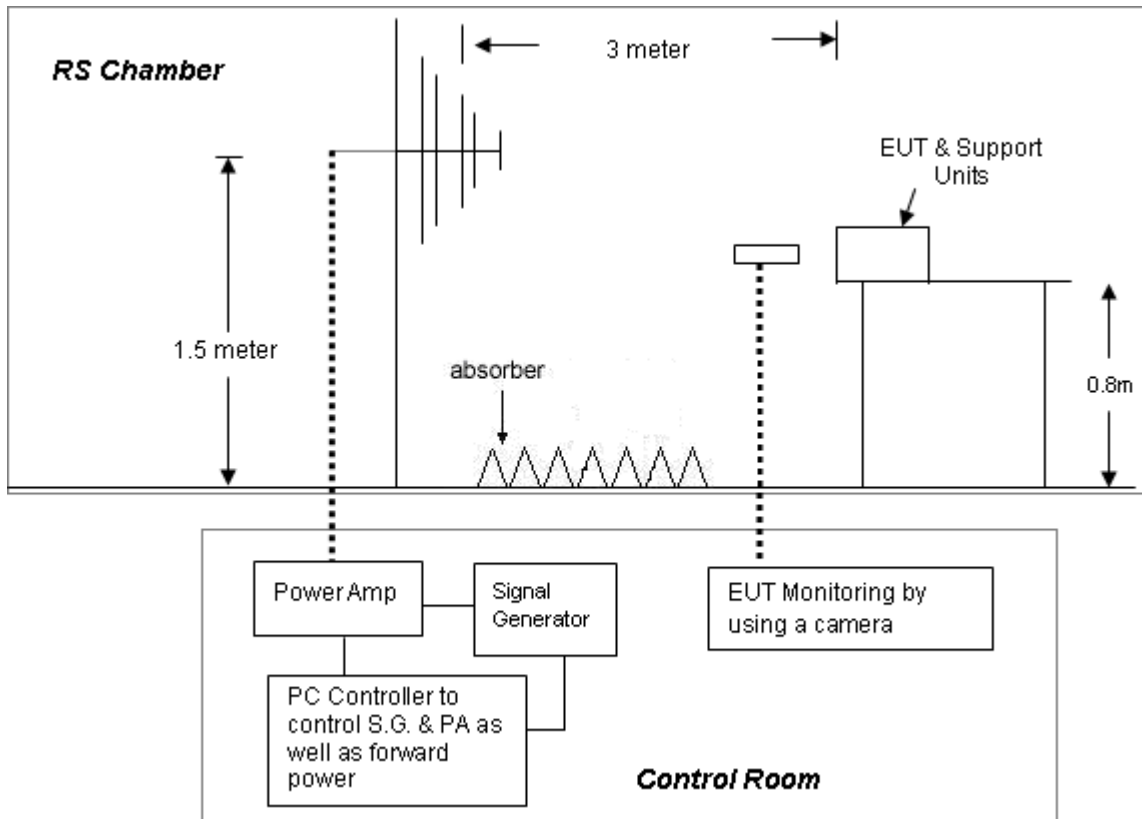

- For the actual test configuration, please refer to the related item – Photographs of the Test Configuration.

#### NOTE:

##### TABLETOP EQUIPMENT

The EUT installed in a representative system as described in section 7 of IEC 61000-4-3 was placed on a non-conductive table 0.8 meters in height. The system under test was connected to the power and signal wire according to relevant installation instructions.

##### FLOOR STANDING EQUIPMENT

The EUT installed in a representative system as described in section 7 of IEC 61000-4-3 was placed on a non-conductive wood support 0.1 meters in height. The system under test was connected to the power and signal wire according to relevant installation instructions.



#### 9.4. Measurement Equipment

Instrument/Ancillary	Manufacturer	Model No.	Serial No.	Calibration Date	Valid Date.
Signal Generator	R&S	SML03	103287	2017.03.22	2018.03.21
Power Sensor	R&S	NR P-Z91	100383	2017.03.22	2018.03.21
Power Meter	R&S	NRP	101206	2017.03.22	2018.03.21
Power Amplifier	BONN	BLWA0830-16 0/100/40D	076659	2017.03.22	2018.03.21
Istropic Electric Field Probe	EST.LINDGRE N	HI-6105	137445	2016.11.20	2017.11.19
EMS Antenna	R&S	HL046E	100028	N/A	N/A
Temperature/ Humidity Meter	feiyang	N/A	101	2017.03.28	2018.03.27
EMC-32	Rohde&Schwa rz	Ver 6.10.0	N/A	N/A	N/A



9.5. Test Result and Data

Final Test Result : **PASS**  
 Pass performance criteria : A  
 Basic Standard : IEC 61000-4-3  
 Model No. : 215LM00071  
 Frequency Range : 80~1000 MHz  
 Temperature : 24°C  
 Relative Humidity : 53%  
 Atmospheric Pressure : 100 kPa  
 Test Date : May 07, 2017

Test Mode: Mode 1,4

Modulation : AM 80% , 1KHz sine wave , Dwell time: 3.0 S				
Frequency Step Size : 1 % of preceding frequency value				
Frequency (MHz)	Antenna Polarization	face	Field strength (V/m)	Result
80~1000	Vertical	Front	3 V/m	A
80~1000	Vertical	Rear	3 V/m	A
80~1000	Vertical	Left	3 V/m	A
80~1000	Vertical	Right	3 V/m	A
80~1000	Horizontal	Front	3 V/m	A
80~1000	Horizontal	Rear	3 V/m	A
80~1000	Horizontal	Left	3 V/m	A
80~1000	Horizontal	Right	3 V/m	A

Test engineer: Sun. Zhang



### 9.6. Test Photographs

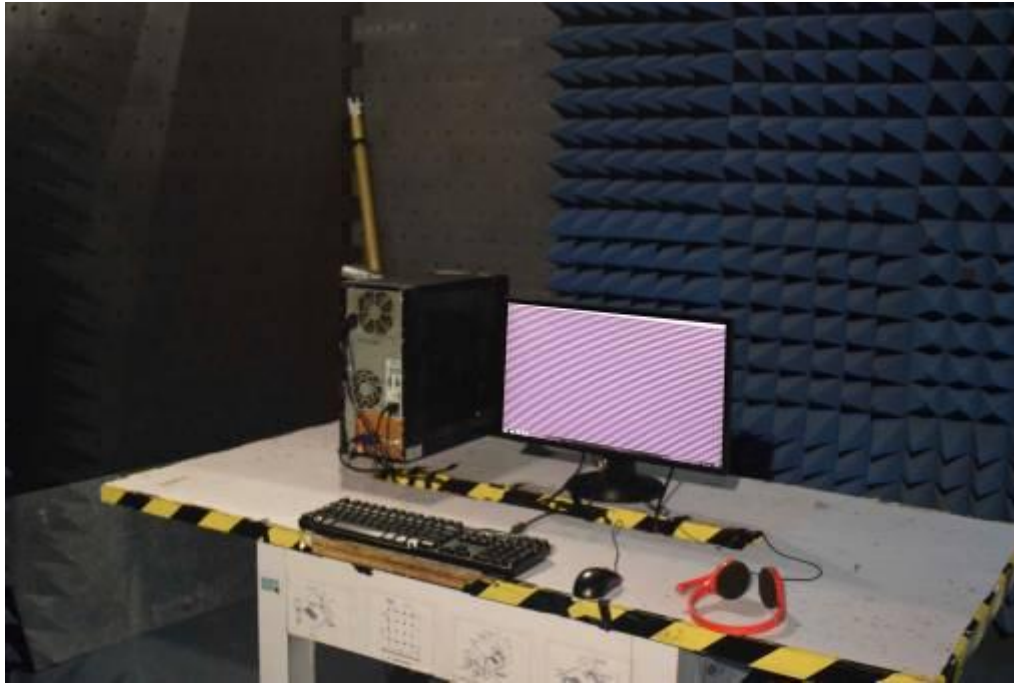



## 10. Electrical Fast Transient/ Burst Immunity Test

### 10.1. Test Procedure

- a. In order to minimize the effect of environmental parameters on test results, the climatic conditions when test is carrying out shall comply with the following requirements:
  - ambient temperature: 15°C to 35°C;
  - relative humidity : 45% to 75%;
  - Atmospheric pressure: 86 Kpa (860 mbar) to 106 Kpa (1060 mbar).
- b. In order to minimize the effect of environmental parameters on test results, the electromagnetic environment of the laboratory shall not influence the test results.
- c. The variety and diversity of equipment and systems to be tested make it difficult to establish general criteria for the evaluation of the effects of fast transients/bursts on equipment and systems.
- d. Test on Power Line:
  - The EFT/B-generator was located on the GRP.  
For floor standing equipment 1,0 m  
For table top equipment 0,5 m
  - The EFT/B-generator provides the ability to apply the test voltage in a non-symmetrical condition to the power supply input terminals of the EUT.
- e. Test on Communication Lines
  - The coupling clamp is composed of a clamp unit for housing the cable (length more than 3 m), and was placed on the GRP.
  - The coupling clamp provides the ability of coupling the fast transient/bursts to the cable under test.
- f. The test results may be classified on the basic of the operating conditions and the functional specification of the equipment under test, according to the following performance criteria :
  - Normal performance within the specification limits.
  - Temporary degradation or loss of function or performance which is self-recoverable.
  - Temporary degradation or loss of function or performance which requires operator intervention or system reset.
  - Degradation or loss of function which is not recoverable due to damage of equipment (components).

### 10.2. Test Severity Levels

The following test severity levels are recommended for the fast transient/burst test :

Open circuit output test voltage $\pm 10\%$		
Level	On Power Supply	On I/O signal, data and control line
1	0.5 KV	0.25 KV
2	1.0 KV	0.50 KV
3	2.0 KV	1.00 KV
4	4.0 KV	2.00 KV
X	Specified	Specified

Remark : “ X ” is an open level. The level is subject to negotiation between the user and manufacturer or is specified by the manufacturer.

### 10.3. TEST SETUP

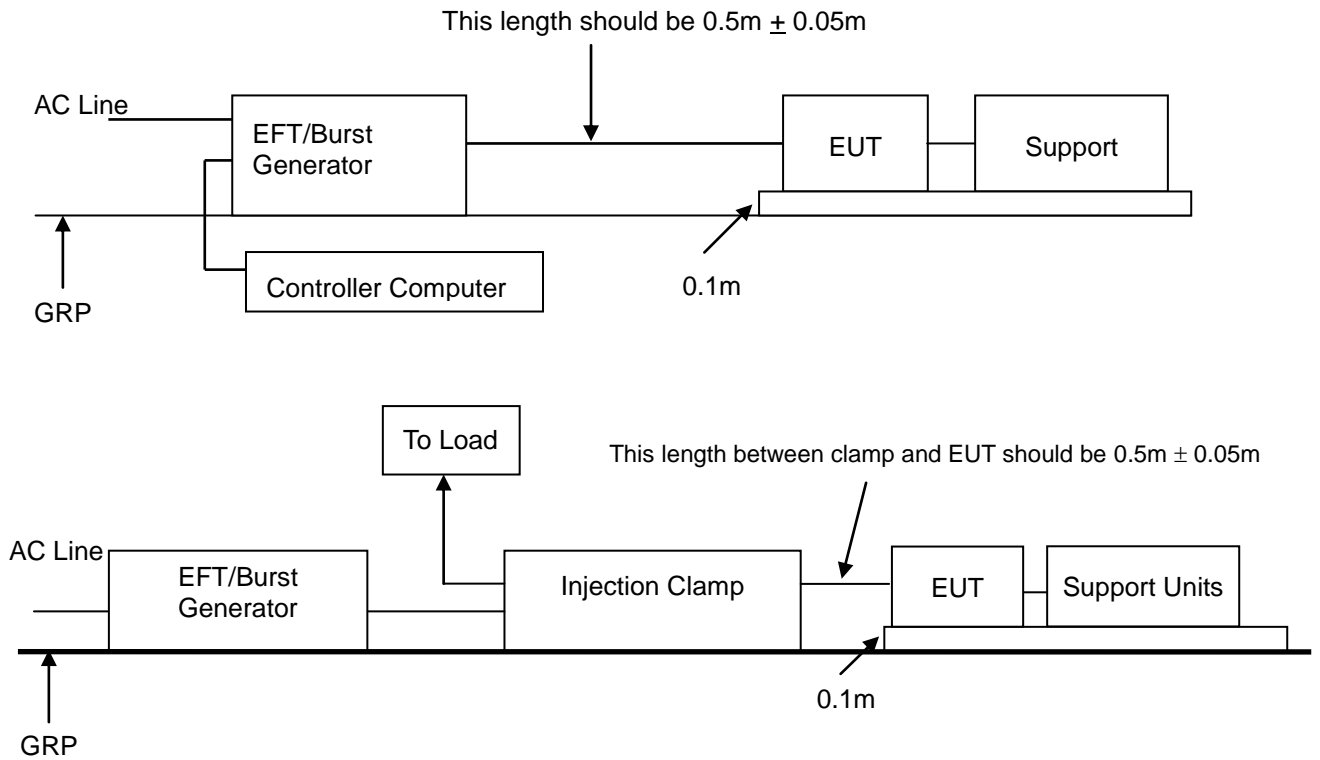

- For the actual test configuration, please refer to the related item – Photographs of the Test Configuration.

**NOTE:**

**TABLETOP EQUIPMENT**

The configuration consisted of a wooden table (0.1m high) standing on the Ground Reference Plane. The GRP consisted of a sheet of aluminum (at least 0.25mm thick and 2.5m square) connected to the protective grounding system. A minimum distance of 0.5m was provided between the EUT and the walls of the laboratory or any other metallic structure.

**FLOOR STANDING EQUIPMENT**

The EUT installed in a representative system as described in section 7 of IEC 61000-4-4 and its cables, were isolated from the Ground Reference Plane by an insulating support that is 0.1-meter thick. The GRP consisted of a sheet of aluminum (at least 0.25mm thick and 2.5m square) connected to the protective grounding system.

### 10.4. Measurement Equipment

Instrument/Ancillary	Manufacturer	Model No.	Serial No.	Calibration Date	Valid Date.
TRANSIENT	EMCPARTNER	TRA2000IN6	901	2016.06.26	2017.06.25
CDN	EMCPARTNER	CDN2000-06-32	121	2017.03.22	2018.03.21
Coupling clamp	EMCPARTNER	CN-EFT1000	547	2017.03.22	2018.03.21
Temperature/ Humidity Meter	Zhicheng	ZC1-11	CEP-TH-005	2017.03.28	2018.03.27





### 10.5. Test Result and Data

Final Test Result : **PASS**  
 Pass performance criteria : B  
 Basic Standard : IEC 61000-4-4  
 Model No. : 215LM00071  
 Test Voltage : On Power Supply --  $\pm 1.0$  kV  
                       : On I/O signal, data and control line --  $\pm 0.5$  kV  
 Temperature : 22°C  
 Relative Humidity : 54%  
 Atmospheric Pressure : 100 kPa  
 Test Date : May 08, 2017

Test Mode: Mode 1,4

Pulse : 5/50 ns		Repetition Rate: <u>5 kHz</u>			
Burst : 15m/300ms					
Test time : 1 min/each condition					
Voltage/ Mode/ Polarity/ Result/ Phase		<u>0.5 kV</u>		<u>1.0 kV</u>	
		+	-	+	-
Power Line	L	---	---	A	A
	N	---	---	A	A
	L-N	---	---	A	A
	PE	---	---	A	A
	L-PE	---	---	A	A
	N-PE	---	---	A	A
	L-N-PE	---	---	A	A

Test engineer: Sun. Zhang



### 10.6. Test Photographs





## 11. Surge Immunity Test

### 11.1. Test Procedure

- a. Climatic conditions  
The climatic conditions shall comply with the following requirements :
  - ambient temperature : 15 °C to 35 °C
  - relative humidity : 10 % to 75 %
  - atmospheric pressure : 86 kPa to 106 kPa ( 860 mbar to 1060 mbar )
- b. Electromagnetic conditions  
the electromagnetic environment of the laboratory shall not influence the test results.
- c. The test shall be performed according the test plan that shall specify the test set-up with
  - generator and other equipment utilized;
  - test level ( voltage/current );
  - generator source impedance;
  - internal or external generator trigger;
  - number of tests : at least five positive and five negative at the selected points;
  - repetition rate : maximum 1/min.
  - inputs and outputs to be tested;
  - representative operating conditions of the EUT;
  - sequence of application of the surge to the circuit;
  - phase angle in the case of AC. power supply;
  - actual installation conditions, for example :
    - AC : neutral earthed,
    - DC : ( + ) or ( - ) earthed to simulated the actual earthing conditions.
- d. If not otherwise specified the surges have to be applied synchronized to the voltage phase at the zero-crossing and the peak value of the AC. voltage wave ( positive and negative ).
- e. The surges have to be applied line to line and line(s) and earth. When testing line to earth, the test voltage has to be applied successively between each of the lines and earth, if there is no other specification.
- f. The test procedure shall also consider the non-linear current-voltage characteristics of the equipment under test. Therefore the test voltage has to be increased by steps up to the test level specified in the product standard or test plan.
- g. All lower levels including the selected test level shall be satisfied. For testing the secondary protection, the output voltage of the generator shall be increased up to the worst-case voltage breakdown level ( let-through level ) of the primary protection.
- h. If the actual operating signal sources are not available, that may be simulated. Under no circumstances may the test level exceed the product specification. The test shall be carried out according to a test plan.
- i. To find all critical points of the duty cycle of the equipment, a sufficient number of positive and negative test pulses shall be applied. For acceptance test previously unstressed equipment shall be used to the protection devices shall be replaced.

### 11.2. Test Severity Level

Level	Open-circuit test voltage, ± 10%, KV
1	0.5
2	1.0
3	2.0
4	4.0
X	Specified
NOTE: "X" is an open class. This level can be specified in the product specification.	

### 11.3. TEST SETUP

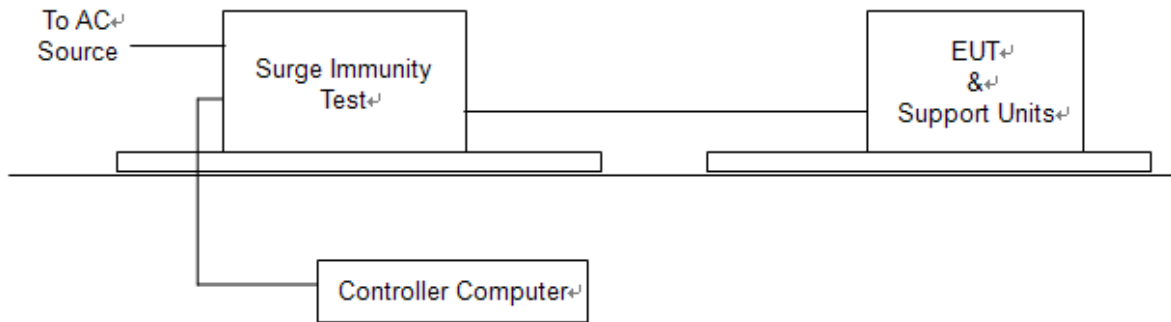

For the actual test configuration, please refer to the related item – Photographs of the Test Configuration.

### 11.4. Measurement Equipment

Instrument/Ancillary	Manufacturer	Model No.	Serial No.	Calibration Date	Valid Date.
TRANSIENT	TESEQ	NSG 3060	1830	2017.02.22	2018.02.21
CDN	TESEQ	CDN 3061	1575	2017.02.22	2018.02.21
CDN	TESEQ	CNV508T5	P 1546167499	2017.02.22	2018.02.21
CDN	TESEQ	CDN HSS-2	41020	2017.02.22	2018.02.21
Temperature/ Humidity Meter	Zhicheng	ZC1-11	CEP-TH-005	2017.03.28	2018.03.27



### 11.5. Test Result and Data

Final Test Result : **PASS**  
Pass performance criteria : B  
Basic Standard : IEC 61000-4-5  
Model No. : 215LM00071  
Test Voltage : Input AC Power Port --  $\pm 0.5/1.0$  kV for Line to Line  
 $\pm 0.5/1.0/2.0$  kV for Line to Ground  
Temperature : 22 °C  
Relative Humidity : 54%  
Atmospheric Pressure : 100 kPa  
Test Date : May 08, 2017

#### Power Port

Test Mode: Mode 1,4

Waveform : 1.2/50 $\mu$ s(8/20 $\mu$ s)    Repetition rate : 60 sec    Time : 20 time/each condition						
/Phase Voltage / Mode / Polarity / Result			0°	90°	180°	270°
<u>0.5/1.0 kV</u>	L-N	+	A	A	A	A
		-	A	A	A	A
<u>0.5/1.0/2.0kV</u>	L-PE	+	A	A	A	A
		-	A	A	A	A
	N-PE	+	A	A	A	A
		-	A	A	A	A

Test engineer: Sun. Zhang



### 11.6. Test Photographs





## 12. Conduction Disturbances induced by Radio-Frequency Fields

### 12.1. Test Procedure

- a. The EUT shall be operated within its intended climatic conditions. The temperature and relative humidity should be recorded.
- b. This test method test can be performed without using a sell shielded enclosure. This is because the disturbance levels applied and the geometry of the setups are not likely to radiated a high amount of energy, especially at the lower frequencies. If under certain circumstances the radiated energy is too high, a shielded enclosure has to be used.
- c. The test shall be performed with the test generator connected to each of the coupling and decoupling devices in turn while the other non-excited RF-input ports of the coupling devices are terminated by a 50 ohm load resistor.
- d. The frequency range is swept from 150 KHz to 80 MHz, using the signal levels established during the setting process, and with the disturbance signal 80% amplitude modulated with a 1KHz sign wave, pausing to adjust the RF-signal level or to switch coupling devices as necessary. The rate of sweep shall no exceed  $1.5 \times 10^{-3}$  decades/s. Where the frequency is swept incrementally, the step size shall no exceed 1% of the start and thereafter 1% of the preceding frequency value.
- e. The dwell time at each frequency shall not be less than the time necessary for the EUT to be exercised, and able to respond. Sensitive frequencies e.g. clock frequency (ies) and harmonics or frequencies of dominant interest shall be analyzed separately.
- f. An alternative test procedure may be adopted, wherein the frequency range is swept incrementally, with a step size not exceeding 4% of the start ad thereafter 4% of the preceding frequency value. The test level should be at least twice the value of the specified test level.
- g. In cases of dispute, the test procedure using a step size not exceeding 1% of the start and thereafter 1% of preceding frequency value shall take precedence.
- h. Attempts should be made to fully exercise the EUT during testing, and to fully interrogate all exercise modes selected for susceptibility.
- i. The use of special exercising programs is recommended.
- j. Testing shall be performed according to a Test Plan, which shall be included in the test report.
- k. It may be necessary to carry out some investigatory testing in order to establish some aspects of the test plan.

### 12.2. Test Severity Levels

Level	Voltage Level ( e.m.f. )
1	1 V
2	3 V
3	10 V
x	Specified
NOTE - x is an open class. This level can be specified in the product specification.	

### 12.3. TEST SETUP

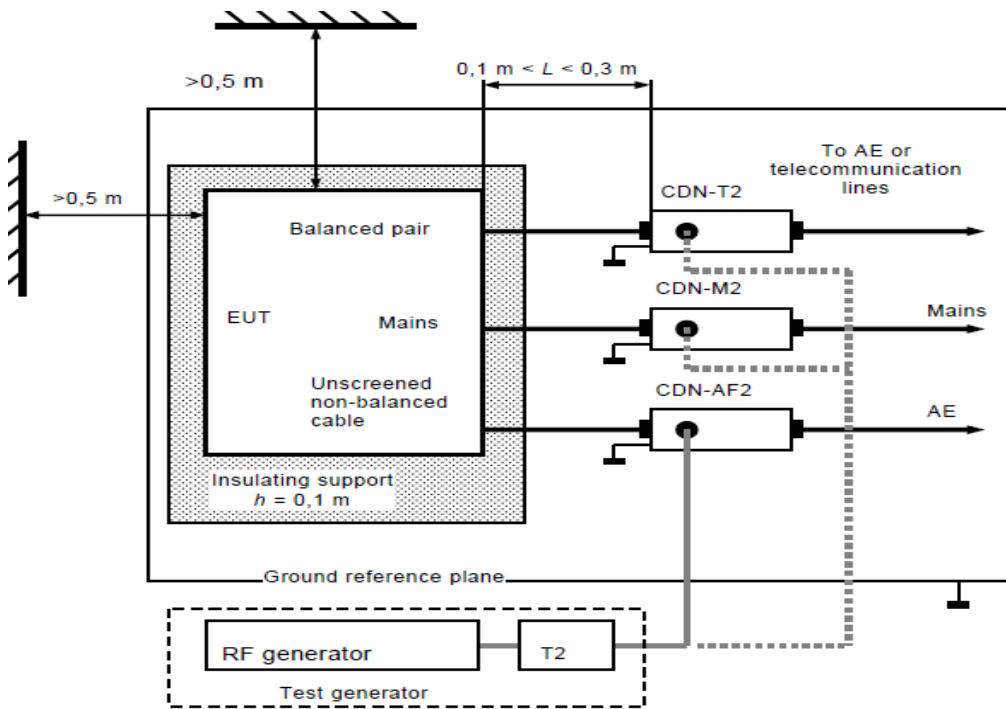

- Note:**
1. The EUT is setup 0.1m above Ground Reference Plane
  2. The CDNs and / or EM clamp used for real test depends on ports and cables configuration of EUT.
  3. For the actual test configuration, please refer to the related item – Photographs of the Test Configuration.

### 12.4. Measurement Equipment

Instrument/Ancillary	Manufacturer	Model No.	Serial No.	Calibration Date	Valid Date.
Conducted immunity test system	FRANKONIA	CIT-10/75	102D1294	2017.03.22	2018.03.21
EM Injection clamp	FCC	F-203I-23MM	536	2017.03.22	2018.03.21
CDN	FRANKONIA	CDN-M2+M3	A3011102	2017.03.22	2018.03.21
CDN	FCC	CDN-M5/32	A3013024	2017.03.22	2018.03.21
CDN	TESEQ	CDN T8-10	43767	2016.09.08	2017.09.07
CDN	TESEQ	CDN T2-10	43762	2016.08.30	2017.08.29
CDN	TESEQ	CDN T4-10	43754	2016.09.08	2017.09.07
CDN	TESEQ	CDN M016	44025	2016.09.12	2017.09.11
6 dB Attenuator	FRANKONIA	N/A	N/A	2017.03.22	2018.03.21
Temperature/ Humidity Meter	Zhicheng	ZC1-11	CEP-TH-005	2017.03.28	2018.03.27
EN61000-4-6	Hubert GmbH	Ver 2.21	N/A	N/A	N/A





**12.5. Test Result and Data**

Final Test Result : **PASS**  
 Pass performance criteria : A  
 Basic Standard : IEC 61000-4-6  
 Model No. : 215LM00071  
 Coupling mode : CDN-(M2+M3) for AC power ports  
                               : CDN-T4 for signal ports  
                               : EM-Clamp for signal ports  
 Temperature : 22°C  
 Relative Humidity : 54%  
 Atmospheric Pressure : 100 kPa  
 Test Date : May 08, 2017

Test Mode: Mode 1,4

Frequency : 0.15~80MHz, Modulation : AM 80%,1KHz sine wave, Dwell time: 3.0s			
Frequency Step Size : 1 % of preceding frequency value			
Frequency	Test mode	Voltage(V)	Result
0.15 ~ 80MHz	Power(M3)	3	A

Test engineer: Sun. Zhang



## 12.6. Test Photographs



### 13. Power Frequency Magnetic Field Immunity Test

#### 13.1. Test Setup

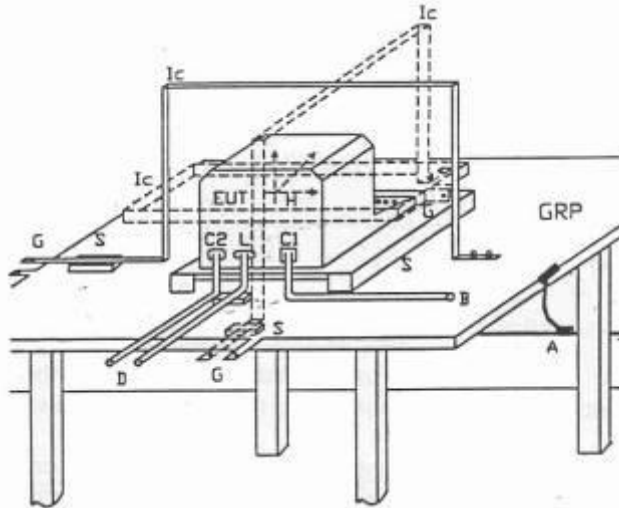

- GPR : Ground plane
- A : Safety earth
- S : Insulating support
- EUT : Equipment under test
- Lc : Induction coil
- E : Earth terminal
- C1 : Power supply circuit
- C2 : Signal circuit
- L : Communication line
- B : To power supply source
- D : To signal source, simulator
- G : To the test generator

#### 13.2. Test Severity Levels

Level	Magnetic field strength (A/m)
1	1
2	3
3	10
4	30
5	100
X <sup>1)</sup>	special

NOTE 1 "X" is an open level. This level can be given in the product specification.

#### 13.3. Measurement Equipment

Instrument/Ancillary	Manufacturer	Model No.	Serial No.	Calibration Date	Valid Date.
TRANSIENT	EMCPARTNER	TRA2000IN6	901	2016.06.26	2017.06.25
H-Filed-Loop	EMCPARTNER	MF1000-1	144	2017.03.22	2018.03.21
Temperature/ Humidity Meter	Zhicheng	ZC1-11	CEP-TH-005	2017.03.28	2018.03.27



13.4. Test Result and Data

Final Test Result : **PASS**  
 Pass performance criteria : A  
 Basic Standard : IEC 61000-4-8  
 Model No. : 215LM00071  
 Temperature : 22°C  
 Relative Humidity : 54%  
 Atmospheric Pressure : 100 kPa  
 Test Date : May 08, 2017

Test Mode: Mode 1,4

Power Frequency Magnetic Field : <u>50</u> Hz, <u>1</u> A/m		
Coil Orientation	Testing duration	Results
X-axis	1.0 Min	A
Y-axis	1.0 Min	A
Z-axis	1.0 Min	A
Power Frequency Magnetic Field : <u>60</u> Hz, <u>1</u> A/m		
Coil Orientation	Testing duration	Results
X-axis	1.0 Min	A
Y-axis	1.0 Min	A
Z-axis	1.0 Min	A

Test engineer: Sun. Zhang



### 13.5. Test Photographs



## 14. Voltage Dips and Voltage Interruptions Immunity Test Setup

### 14.1. Test Conditions

1. Source voltage and frequency : AC 100/230/240V / 50Hz, Single phase.
2. Test of interval : 10 sec.
3. Level and duration : Sequence of 3 dips/interrupts.
4. Voltage rise (and fall) time : 1 ~ 5  $\mu$ s.
5. Test severity :

Voltage dips and Interrupt reduction (%)	Test Duration (period)
>95%	250
30%	25
>95%	0.5

### 14.2. TEST SETUP

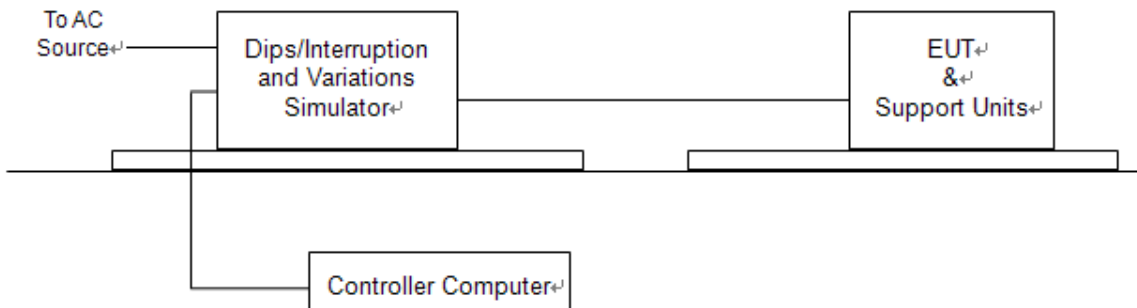

For the actual test configuration, please refer to the related item – Photographs of the Test Configuration.

### 14.3. Measurement Equipment

Instrument/Ancillary	Manufacturer	Model No.	Serial No.	Calibration Date	Valid Date.
TRANSIENT	EMCPARTNER	TRA2000IN6	901	2016.06.26	2017.06.25
Temperature/ Humidity Meter	Zhicheng	ZC1-11	CEP-TH-005	2017.03.28	2018.03.27



14.4. Test Result and Data

Final Test Result : **PASS**  
 Pass performance criteria : C for voltage interruption, B for voltage dips  
 Basic Standard : IEC 61000-4-11  
 Model No. : 215LM00071  
 Temperature : 22°C  
 Relative Humidity : 54%  
 Atmospheric Pressure : 100 kPa  
 Test Date : May 08, 2017

Test Mode: Mode 1,4

Voltage(UT): AC 230 V/240V 50 Hz Interval(s) : 10s Times : 3										
Test mod	Test level UT %	Durations (period / ms )	Phase / Result							
			0	45	90	135	180	225	270	315
Voltage interruptions	>95%	250	C	C	C	C	C	C	C	C
Voltage dips	30%	25	A	A	A	A	A	A	A	A
	>95%	0.5	A	A	A	A	A	A	A	A

Test Mode: Mode 1,4

Voltage(UT): AC 100 V 50 Hz Interval(s) : 10s Times : 3										
Test mod	Test level UT %	Durations (period / ms )	Phase / Result							
			0	45	90	135	180	225	270	315
Voltage interruptions	>95%	250	C	C	C	C	C	C	C	C
Voltage dips	30%	25	B	B	B	B	B	B	B	B
	>95%	0.5	B	B	B	B	B	B	B	B

Test engineer: Sun. Zhang



### 14.5. Test Photographs







## 15. Photographs of EUT

### 1) EUT Photo



### 2) EUT Photo

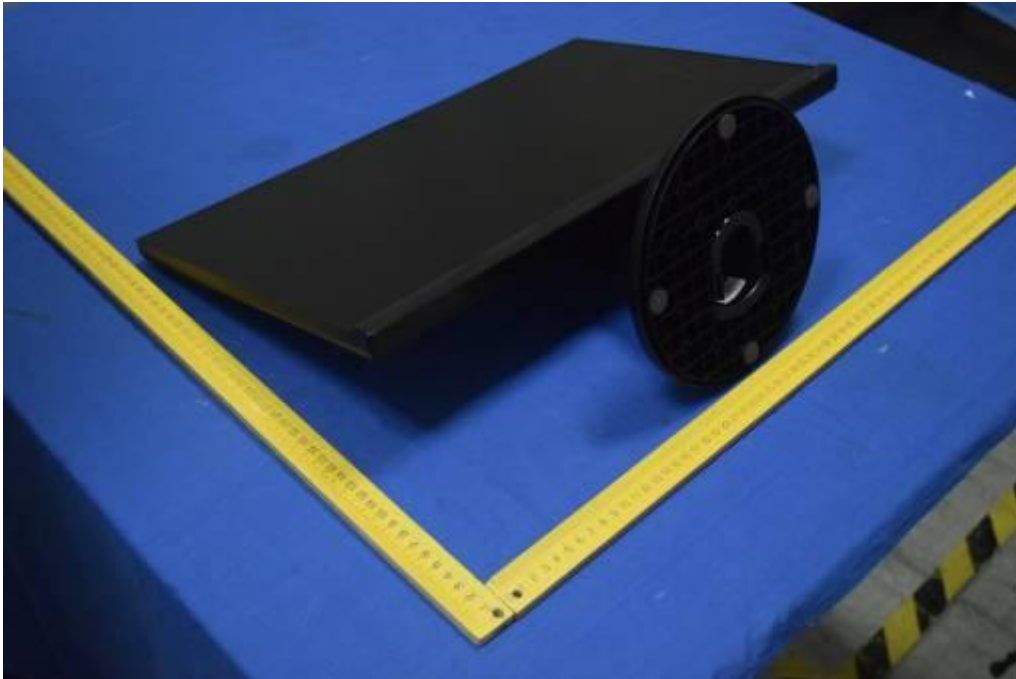



3) EUT Photo



4) EUT Photo





5) EUT Photo

