



EMC TEST REPORT

Authorized under Declaration of Conformity

According to

EN 55032: 2012+AC 2013

EN 61000-3-2 : 2014

EN 61000-3-3 : 2013

CISPR 32 : 2012

AS/NZS CISPR 32 : 2013

Applicant : TPV Electronics (Fujian) Co., Ltd.
Rongqiao Economic and Technological
Address : Development Zone, Fuqing City, Fujian Province,
P.R. China
Equipment : LCD Monitor
280LM00004; U2879***
Model No. : (The “*” could be any alphanumeric character
including blank for marketing differentiation.)

I HEREBY CERTIFY THAT :

The sample was received on Jan 23, 2017 and the testing was carried out on Feb 22, 2017 at CerpPASS Technology Corp. The test result refers exclusively to the test presented test model / sample. Without written approval of CerpPASS Technology Corp., the test report shall not be reproduced except in full.



EMC TEST REPORT

Issued by:

Cerpass Technology (Suzhou) Co.,Ltd

No.66,Tangzhuang Road, Suzhou Industrial Park, Jiangsu 215006, China

Tel:86-512-6917-5888

Fax:86-512-6917-5666

The test record, data evaluation & Equipment Under Test configurations represented herein are true and accurate accounts of the measurements of the samples EMC characteristics under the conditions specified in this report.

The above equipment was tested by Cerpass Technology Corp. for compliance with the requirements of technical standards specified above under the EMC Directive. The results of testing in this report apply only to the product/system, which was tested. Other similar equipment will not necessarily produce the same results due to production tolerance and measurement uncertainties

Approved by:

Miro Chueh
EMC/RF B.U. Manager

Laboratory Accreditation:

Cerpass Technology Corporation Test Laboratory

NVLAP LAB Code:	200954-0
TAF LAB Code:	1439

Cerpass Technology(SuZhou) Co., Ltd.

NVLAP LAB Code:	200814-0
CNAS LAB Code:	L5515



Contents

1. Summary of Test Procedure and Test Results	5
2. Test Configuration of Equipment under Test	6
2.1. Feature of Equipment under Test	6
2.2. Test Mode and Test Manner	7
2.3. Description of Support Unit	8
2.4. General Information of Test	9
2.5. Measurement Uncertainty	10
3. Test of Conducted Emission	11
3.1. Test Limit	11
3.2. Test Procedures	14
3.3. Typical Test Setup	14
3.4. Measurement Equipment	15
3.5. Test Data and Result	16
3.6. Test Photographs	21
4. Test of Radiated Emission	22
4.1. Test Limit	22
4.2. Test Procedures	25
4.3. Typical Test Setup	25
4.4. Measurement Equipment	26
4.5. Test Result and Data (30MHz ~ 1000MHz)	27
4.6. Test Result and Data (1000MHz ~ 6000MHz)	31
4.7. Test Photographs (30MHz ~ 1000MHz)	35
4.8. Test Photographs (1000MHz ~ 6000MHz)	36
5. Harmonics Test	37
5.1. Limits of Harmonics Current Measurement	37
5.2. Measurement Equipment	38
5.3. Test Result and Data	39
5.4. Test Photographs	43
6. Voltage Fluctuations Test	44
6.1. Test Procedure	44
6.2. Measurement Equipment	44
6.3. Test Result and Data	45
6.4. Test Photographs	49
7. Photographs of EUT	50



History of this test report

ORIGINAL.

Additional attachment as following record:

Report No	Version	Date	Description
SECE1701225	Rev 01	Mar 04, 2017	Initial Issue



1. Summary of Test Procedure and Test Results

EMISSION [EN55032: 2012+AC 2013]			
Standard	Item	Result	Remarks
EN55032: 2012+AC 2013 AS/NZS CISPR 32 : 2013 CISPR 32 : 2012	Conducted (Power Port)	PASS	Meet Class B Limit Minimum passing margin(AVG) is -9.04 dB at 8.7299 MHz
	Conducted (Telecom port)	N/A	N/A
	Radiated	PASS	Meets Class B Limit Minimum passing margin(QP) is -4.02 dB at 227.4000MHz
EN 61000-3-2: 2014	Harmonic current emissions	PASS	Meet Class D Limit
EN61000-3-3:2013	Voltage fluctuations & flicker	PASS	Meets the requirements



2. Test Configuration of Equipment under Test

2.1. Feature of Equipment under Test

Product Name:	LCD Monitor	
Model Name:	280LM00004; U2879*** (The "*" could be any alphanumeric character including blank for marketing differentiation.)	
Model Discrepancy:	Different sales market.	
Housing material:	Plastic case	
EUT Highest Frequency:	317.49MHz	
Adapter #1	Model	ADPC2090
	Input	100V – 240V ~ 1.3A 50-60Hz
	Output	20V,4.5A
Adapter #2	Model	ADPC2065
	Input	100V – 240V ~ 1.5A 50-60Hz
	Output	20V,3.25A
AC Power Cord Type:	Non-shielded, 1.2m&1.5m&1.8m	

Note: Please refer to user manual.

I/O PORT:

I/O PORT TYPE	Quantity
A. VGA Port	1
B. DVI Port	1
C. Display Port	1
D. HDMI Port	1
E. Audio Port	1
F. DC Port	1



2.2. Test Mode and Test Manner

Test Manner

- a During testing, the interface cables and equipment positions were varied according to Europe Standard.
- b Running "H" pattern and Colour bars.
- c The complete test system included PC, USB Keyboard, USB Mouse, Earphone and EUT for EMI&EMS test
- d Adjust the EUT, then test.

The pre-test for CE modes

Mode 1: Full system (VGA mode 1920*1080@60Hz) with adapter 2 (110V/60Hz)

Mode 2: Full system (VGA mode 1920*1080@60Hz) with adapter 2 (230V/50Hz)

“Test mode 1, 2” were reported as final data.

The pre-test for RE(Below 1GHz) modes

Mode 1: Full system (DVI mode 3840*2160@30Hz) with adapter 1 (110V/60Hz)

Mode 2: Full system (DVI mode 3840*2160@30Hz) with adapter 1 (230V/50Hz)

“Test mode 1, 2” were reported as final data.

The pre-test for RE(Above 1GHz) modes

Mode 1: Full system (HDMI mode 3840*2160@30Hz) with adapter 1 (110V/60Hz)

Mode 2: Full system (HDMI mode 3840*2160@30Hz) with adapter 1 (230V/50Hz)

“Test mode 1, 2” were reported as final data.

The pre-test for Harmonic/Flicker modes

Test Mode 1: Full system (VGA mode 1920*1080@60Hz) with adapter 1

Test Mode 2: Full system (DVI mode 3840*2160@30Hz) with adapter 1

Test Mode 3: Full system (HDMI mode 3840*2160@30Hz) with adapter 1

Test Mode 4: Full system (Display mode 3840*2160@60Hz) with adapter 1

Test Mode 5: Full system (VGA mode 1920*1080@60Hz) with adapter 2

Test Mode 6: Full system (DVI mode 3840*2160@30Hz) with adapter 2

Test Mode 7: Full system (HDMI mode 3840*2160@30Hz) with adapter 2

Test Mode 8: Full system (Display mode 3840*2160@60Hz) with adapter 2

“Test mode 1, 2,3,4,5,6,7,8” were reported as final data.

Remark: The SECE1701225 CE/RE test pattern is evaluated in the worst mode of
SECE1608170



2.3. Description of Support Unit

Device	Manufacturer	Model No.	Description
PC	HP	HP Compaq Elite 8200 MTPC	Non-Shielded ,1.8m(R33001)
USB Keyboard	DELL	SK-8115	T3A002
USB Mouse	DELL	G0K02XYK	R41108
Earphone	SALAR	V18	N/A

Use Cable:

Cable	Quantity	Description
USB Cable	1	Shielded, 1.8m, with one ferrite core bonded
USB Cable	1	Shielded, 1.2m
Audio Cable	1	No-Shielded, 1.8m
VGA Cable	1	Shielded, 1.2m&1.5m&1.8m, with two ferrite core bonded
DVI Cable	1	Shielded, 1.2m&1.5m&1.8m, with two ferrite core bonded
HDMI Cable	1	Shielded, 1.2m&1.5m&1.8m
Display Cable	1	Shielded, 1.2m&1.5m&1.8m



2.4. General Information of Test

<input type="checkbox"/>	Test Site	CerpPASS Technology Corporation Test Laboratory Address: No.10, Ln. 2, Lianfu St., Luzhu Dist., Taoyuan City 33848, Taiwan (R.O.C.) Tel:+886-3-3226-888 Fax:+886-3-3226-881 Address: No.68-1, Shihbachongsi, Shihding Township, New Taipei City 223, Taiwan, R.O.C. Tel: +886-2-2663-8582
	FCC	TW1079, TW1061,390316, 228391, 641184
	IC	4934B-1, 4934E-1, 4934E-2
	VCCI	T-2205 for Telecommunication Test C-4663 for Conducted emission test R-3428, R-4218 for Radiated emission test G-812, G-813 for radiated disturbance above 1GHz
<input checked="" type="checkbox"/>	Test Site	CerpPASS Technology (Suzhou) Co.,Ltd Address: No.66,Tangzhuang Road, Suzhou Industrial Park, Jiangsu 215006, China Tel: +86-512-6917-5888 Fax: +86-512-6917-5666
	FCC	331395
	IC	7290A-1, 7290A-2
	VCCI	T-1945 for Telecommunication Test C-2919 for Conducted emission test R-2670 for Radiated emission test G-227 for radiated disturbance above 1GHz
Frequency Range Investigated:		Conducted: from 150kHz to 30 MHz Radiation: from 30 MHz to 6000MHz
Test Distance :		The test distance of radiated emission below 1GHz from antenna to EUT is 10 M. The test distance of radiated emission above 1GHz from antenna to EUT is 3 M.



2.5. Measurement Uncertainty

Where relevant, the following measurement uncertainty levels have been estimated for tests performed on the EUT as specified in CISPR 16-4-2:

Measurement	Frequency	Uncertainty
Conducted emissions(LINE)	9KHz-30MHz	+/- 0.7738 dB
Conducted emissions(NEUTRAL)	9KHz-30MHz	+/- 0.7886 dB

Measurement	Polarity	Frequency	Uncertainty
Radiated emissions (below 1GHz)	H	30MHz ~ 200MHz	+/- 3.8909dB
		200MHz ~1000MHz	+/- 3.6555dB
	V	30MHz ~ 200MHz	+/- 3.8948dB
		200MHz ~1000MHz	+/- 3.6538dB
Radiated emissions (above 1GHz)	H	1000MHz ~18000MHz	+/- 3.8948 dB
		18000MHz ~40000MHz	+/-3.8844dB
	V	1000MHz ~18000MHz	+/- 3.8906dB
		18000MHz ~40000MHz	+/- 3.8744dB

This uncertainty represents an expanded uncertainty expressed at approximately the 95% confidence level using a coverage factor of k=2.

Consistent with industry standard (e.g. CISPR 22: 2008, clause 11, Measurement Uncertainty) determining compliance with the limits shall be base on the results of the compliance measurement. Consequently the measure emissions being less than the maximum allowed emission result in this be a compliant test or passing test.



3. Test of Conducted Emission

3.1. Test Limit

Conducted Emissions were measured from 150 kHz to 30 MHz with a bandwidth of 9 kHz and return leads of the EUT according to the methods defined in European Standard EN 55032.

Table A.8 – Requirements for conducted emissions from the AC mains power ports of Class A equipment

Applicable to				
1. AC mains power ports (3.1.1)				
Table clause	Frequency range MHz	Coupling device (see Table A.7)	Detector type / bandwidth	Class A limits dB(μ V)
A8.1	0,15 – 0,5	AMN	Quasi Peak / 9 kHz	79
	0,5 – 30			73
A8.2	0,15 – 0,5	AMN	Average / 9 kHz	66
	0,5 – 30			60

NOTE Apply A8.1 and A8.2 across the entire frequency range.

Table A.9 – Requirements for conducted emissions from the AC mains power ports of Class B equipment

Applicable to				
1. AC mains power ports (3.1.1)				
Table clause	Frequency range MHz	Coupling device (see Table A.7)	Detector type / bandwidth	Class B limits dB(μ V)
A9.1	0,15 – 0,5	AMN	Quasi Peak / 9 kHz	66 – 56
	0,5 – 5			56
	5 – 30			60
A9.2	0,15 – 0,5	AMN	Average / 9 kHz	56 – 46
	0,5 – 5			46
	5 – 30			50

NOTE Apply A9.1 and A9.2 across the entire frequency range.



Table A.10 – Requirements for asymmetric mode conducted emissions from Class A equipment

Applicable to					
1. wired network ports (3.1.30)					
2. optical fibre ports (3.1.24) with metallic shield or tension members					
3. antenna ports (3.1.3)					
Table clause	Frequency range MHz	Coupling device (see Table A.7)	Detector type / bandwidth	Class A voltage limits dB(μV)	Class A current limits dB(μA)
A10.1	0,15 – 0,5	AAN	Quasi Peak / 9 kHz	97 – 87	n/a
	0,5 – 30			87	
	0,15 – 0,5	AAN	Average / 9 kHz	84 – 74	
	0,5 – 30			74	
A10.2	0,15 – 0,5	CVP and current probe	Quasi Peak / 9 kHz	97 – 87	53 – 43
	0,5 – 30			87	43
	0,15 – 0,5	CVP and current probe	Average / 9 kHz	84 – 74	40 – 30
	0,5 – 30			74	30
A10.3	0,15 – 0,5	Current Probe	Quasi Peak / 9 kHz	n/a	53 – 43
	0,5 – 30				43
	0,15 – 0,5	Current Probe	Average / 9 kHz		40 – 30
	0,5 – 30				30
NOTE 1 The choice of coupling device and measurement procedure is defined in Annex C.					
NOTE 2 AC mains power ports shall meet the limits given in Table A.8.					
NOTE 3 The test shall cover the entire frequency range.					
NOTE 4 The application of the voltage and/or current limits is dependent on the measurement procedure used. Refer to Table C.1 for applicability.					
NOTE 5 Testing is required at only one EUT supply voltage and frequency.					
NOTE 6 Applicable to ports listed above and intended to connect to cables longer than 3 m.					



Table A.11 – Requirements for asymmetric mode conducted emissions from Class B equipment

Applicable to					
1. wired network ports (3.1.30) 2. optical fibre ports (3.1.24) with metallic shield or tension members 3. broadcast receiver tuner ports (3.1.8) 4. antenna ports (3.1.3)					
Table clause	Frequency range MHz	Coupling device (see Table A.7)	Detector type / bandwidth	Class B voltage limits dB(μV)	Class B current limits dB(μA)
A11.1	0,15 – 0,5	AAN	Quasi Peak / 9 kHz	84 – 74	n/a
	0,5 – 30			74	
	0,15 – 0,5	AAN	Average / 9 kHz	74 – 64	
	0,5 – 30			64	
A11.2	0,15 – 0,5	CVP and current probe	Quasi Peak / 9 kHz	84 – 74	40 – 30
	0,5 – 30			74	30
	0,15 – 0,5	CVP and current probe	Average / 9 kHz	74 – 64	30 – 20
	0,5 – 30			64	20
A11.3	0,15 – 0,5	Current Probe	Quasi Peak / 9 kHz	n/a	40 – 30
	0,5 – 30				30
	0,15 – 0,5	Current Probe	Average / 9 kHz		30 – 20
	0,5 – 30				20
NOTE 1 The choice of coupling device and measurement procedure is defined in Annex C. NOTE 2 Screened ports including TV broadcast receiver tuner ports are tested with a common-mode impedance of 150 Ω. This is typically accomplished with the screen terminated by 150 Ω to earth. NOTE 3 AC mains power ports shall meet the limits given in Table A.9. NOTE 4 The test shall cover the entire frequency range. NOTE 5 The application of the voltage and/or current limits is dependent on the measurement procedure used. Refer to Table C.1 for applicability. NOTE 6 Testing is required at only one EUT supply voltage and frequency. NOTE 7 Applicable to ports listed above and intended to connect to cables longer than 3 m.					

3.2. Test Procedures

- a. The EUT was placed on a desk 0.8 meters height from the metal ground plane and 0.4 meter from the conducting wall of the shielding room and it was kept at least 0.8 meters from any other grounded conducting surface.
- b. Connect EUT to the power mains through a Artificial Mains Network (AMN).
- c. All the support units are connecting to the other AMN.
- d. The AMN provides 50 ohm coupling impedance for the measuring instrument.
- e. The CISPR states that a 50 ohm, 50 micro-Henry AMN should be used.
- f. Both sides of AC line were checked for maximum conducted interference.
- g. The frequency range from 150 kHz to 30 MHz was searched
- h. Set the test-receiver system to Peak Detect Function and Specified Bandwidth with Maximum Hold Mode.

3.3. Typical Test Setup

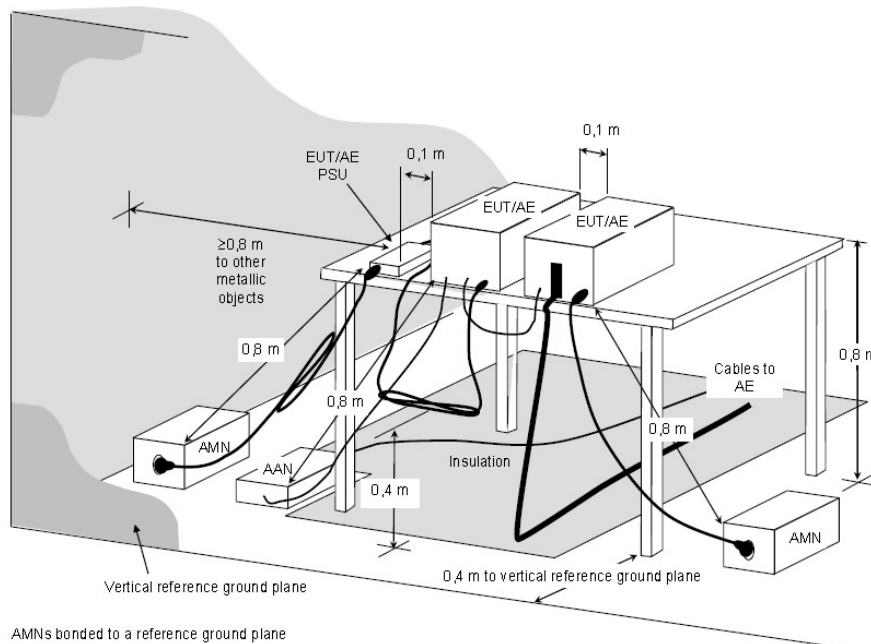

NOTE The 0,8 m distance specified between EUT/AE/PSU and AMN/AAN, is applicable only to the EUT being measured. If the device is AE then it shall be $\geq 0,8$ m.

Figure D.2 – Example measurement arrangement for table-top EUT (Conducted emission measurement – alternative 1)



3.4. Measurement Equipment

Instrument/Ancillary	Manufacturer	Model No.	Serial No.	Calibration Date	Valid Date.
Test Receiver	R&S	ESCI	100565	2016.07.07	2017.07.06
AMN	R&S	ESH2-Z5	100182	2016.08.31	2017.08.30
Two-Line V-Network	R&S	ENV216	100325	/	/
ISN	FCC	FCC-TLISN-T2-02	20379	2016.03.26	2017.03.25
ISN	FCC	FCC-TLISN-T4-02	20380	2016.06.24	2017.06.24
ISN	FCC	FCC-TLISN-T8-02	20381	2016.03.26	2017.03.25
ISN	TESEQ	ISN ST08	30175	2016.03.26	2017.03.25
Current Probe	R&S	EZ-17	100303	2016.03.26	2017.03.25
Passive Voltage Probe	R&S	ESH2-Z3	100026	2016.03.26	2017.03.25
Pulse Limiter	R&S	ESH3-Z2	100529	2016.03.26	2017.03.25
Temperature/ Humidity Meter	Zhicheng	ZC1-11	CEP-TH-004	2016.03.29	2017.03.28
EZ-EMC	Fala	Ver CT3A1	N/A	N/A	N/A



3.5. Test Data and Result

3.5.1 Conducted Emission for Power Port Test Data

Test Mode :	Mode 1: Full system (VGA mode 1920*1080@60Hz) with adapter 2 (110V/60Hz)		
AC Power :	AC 110V/60Hz	Phase :	LINE
Equipment :	LCD Monitor	Model No :	280LM00004
Temperature :	21°C	Humidity :	53%
Pressure(mbar) :	1001	Date:	2017/02/15

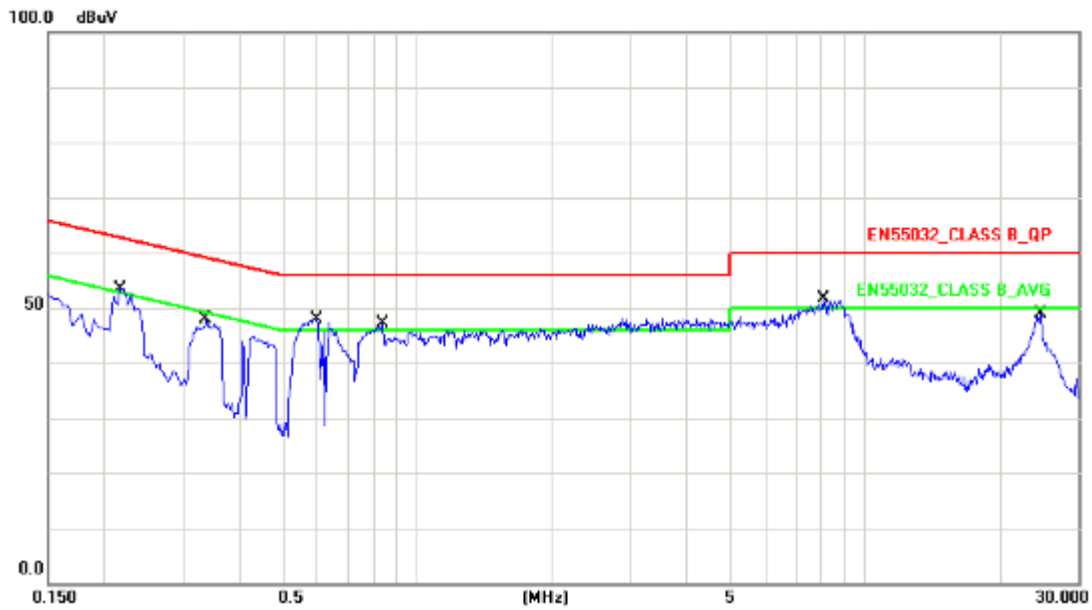

No.	Frequency (MHz)	Factor (dB)	Reading (dBuV)	Level (dBuV)	Limit (dBuV)	Margin (dB)	Detector
1	0.2180	10.12	41.08	51.20	62.89	-11.69	QP
2	0.2180	10.12	31.56	41.68	52.89	-11.21	AVG
3	0.3379	10.14	35.08	45.22	59.25	-14.03	QP
4	0.3379	10.14	24.76	34.90	49.25	-14.35	AVG
5	0.5980	10.16	35.49	45.65	56.00	-10.35	QP
6	0.5980	10.16	13.94	24.10	46.00	-21.90	AVG
7	0.8420	10.15	32.29	42.44	56.00	-13.56	QP
8	0.8420	10.15	9.27	19.42	46.00	-26.58	AVG
9	8.0780	10.25	34.81	45.06	60.00	-14.94	QP
10	8.0780	10.25	27.65	37.90	50.00	-12.10	AVG
11	24.7340	10.43	31.45	41.88	60.00	-18.12	QP
12	24.7340	10.43	25.74	36.17	50.00	-13.83	AVG

Note: Measurement Level = Reading Level + Correct Factor



Test Mode :	Mode 1: Full system (VGA mode 1920*1080@60Hz) with adapter 2 (110V/60Hz)		
AC Power :	AC 110V/60Hz	Phase :	NEUTRAL
Equipment :	LCD Monitor	Model No :	280LM00004
Temperature :	21°C	Humidity :	53%
Pressure(mbar) :	1001	Date:	2017/02/15

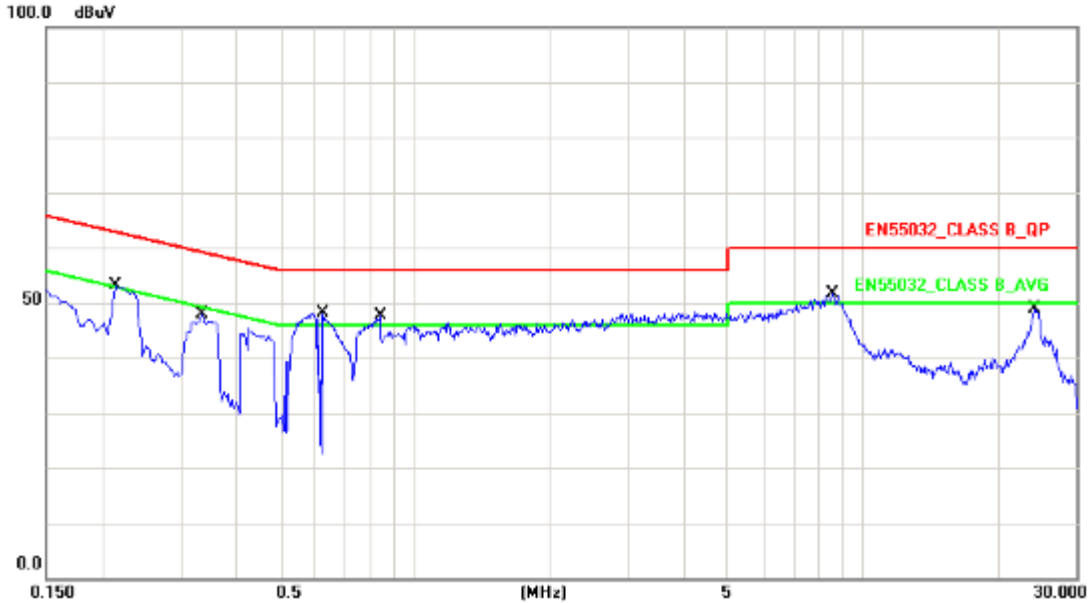

No.	Frequency (MHz)	Factor (dB)	Reading (dBuV)	Level (dBuV)	Limit (dBuV)	Margin (dB)	Detector
1	0.2140	10.12	40.07	50.19	63.04	-12.85	QP
2	0.2140	10.12	28.38	38.50	53.04	-14.54	AVG
3	0.3339	10.14	35.13	45.27	59.35	-14.08	QP
4	0.3339	10.14	25.87	36.01	49.35	-13.34	AVG
5	0.6260	10.15	30.84	40.99	56.00	-15.01	QP
6	0.6260	10.15	5.03	15.18	46.00	-30.82	AVG
7	0.8380	10.15	33.60	43.75	56.00	-12.25	QP
8	0.8380	10.15	10.76	20.91	46.00	-25.09	AVG
9	8.5740	10.26	34.40	44.66	60.00	-15.34	QP
10	8.5740	10.26	27.77	38.03	50.00	-11.97	AVG
11	24.2300	10.41	31.60	42.01	60.00	-17.99	QP
12	24.2300	10.41	25.74	36.15	50.00	-13.85	AVG

Note: Measurement Level = Reading Level + Correct Factor



Test Mode :	Mode 2: Full system (VGA mode 1920*1080@60Hz) with adapter 2 (230V/50Hz)		
AC Power :	AC 230V/50Hz	Phase :	LINE
Equipment :	LCD Monitor	Model No :	280LM00004
Temperature :	21°C	Humidity :	53%
Pressure(mbar) :	1001	Date:	2017/02/15

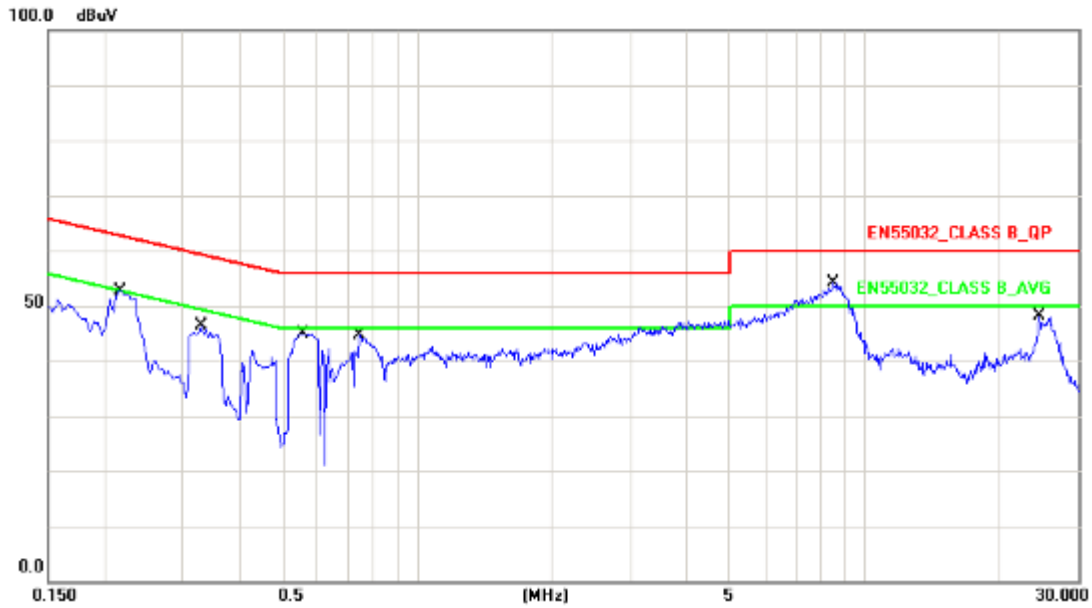

No.	Frequency (MHz)	Factor (dB)	Reading (dBuV)	Level (dBuV)	Limit (dBuV)	Margin (dB)	Detector
1	0.2180	10.12	40.67	50.79	62.89	-12.10	QP
2	0.2180	10.12	30.53	40.65	52.89	-12.24	AVG
3	0.3300	10.14	33.29	43.43	59.45	-16.02	QP
4	0.3300	10.14	24.96	35.10	49.45	-14.35	AVG
5	0.5580	10.16	33.26	43.42	56.00	-12.58	QP
6	0.5580	10.16	20.41	30.57	46.00	-15.43	AVG
7	0.7500	10.14	32.08	42.22	56.00	-13.78	QP
8	0.7500	10.14	14.88	25.02	46.00	-20.98	AVG
9	8.5140	10.26	37.22	47.48	60.00	-12.52	QP
10	8.5140	10.26	30.43	40.69	50.00	-9.31	AVG
11	24.5620	10.42	32.23	42.65	60.00	-17.35	QP
12	24.5620	10.42	27.15	37.57	50.00	-12.43	AVG

Note: Measurement Level = Reading Level + Correct Factor



Test Mode :	Mode 2: Full system (VGA mode 1920*1080@60Hz) with adapter 2 (230V/50Hz)		
AC Power :	AC 230V/50Hz	Phase :	NEUTRAL
Equipment :	LCD Monitor	Model No :	280LM00004
Temperature :	21°C	Humidity :	53%
Pressure(mbar) :	1001	Date:	2017/02/15

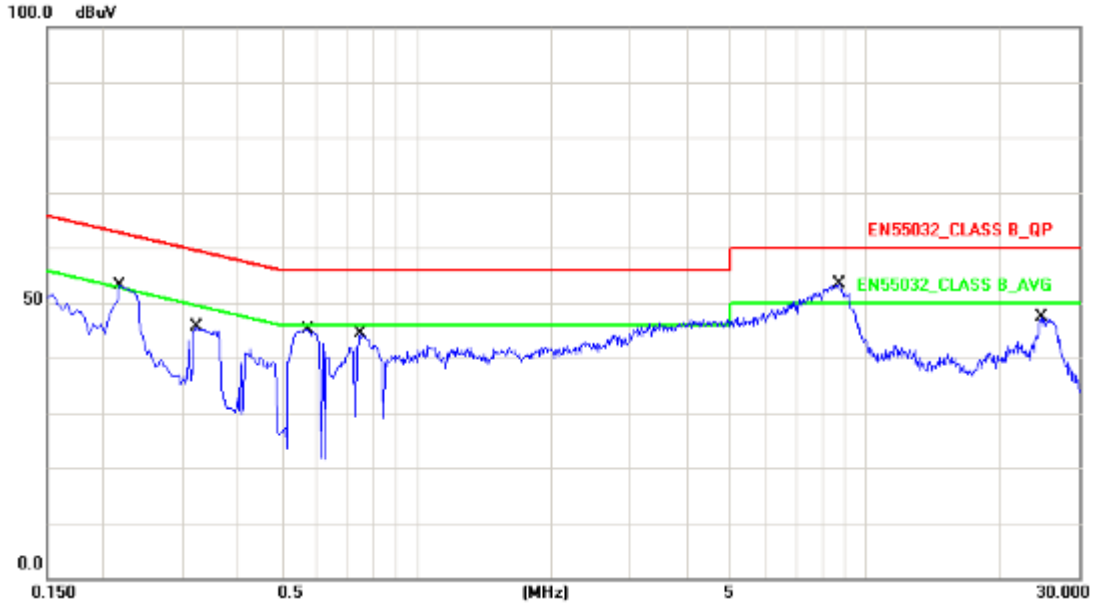

No.	Frequency (MHz)	Factor (dB)	Reading (dBuV)	Level (dBuV)	Limit (dBuV)	Margin (dB)	Detector
1	0.2180	10.12	40.90	51.02	62.89	-11.87	QP
2	0.2180	10.12	30.50	40.62	52.89	-12.27	AVG
3	0.3220	10.14	33.06	43.20	59.65	-16.45	QP
4	0.3220	10.14	21.26	31.40	49.65	-18.25	AVG
5	0.5740	10.16	32.90	43.06	56.00	-12.94	QP
6	0.5740	10.16	17.73	27.89	46.00	-18.11	AVG
7	0.7500	10.14	32.12	42.26	56.00	-13.74	QP
8	0.7500	10.14	14.70	24.84	46.00	-21.16	AVG
9	8.7299	10.26	37.27	47.53	60.00	-12.47	QP
10	8.7299	10.26	30.70	40.96	50.00	-9.04	AVG
11	24.7300	10.43	31.13	41.56	60.00	-18.44	QP
12	24.7300	10.43	25.51	35.94	50.00	-14.06	AVG

Note: Measurement Level = Reading Level + Correct Factor

Test engineer: Sun. Zhang



3.5.2 Conducted Emission for Telecommunication Port Test Data

Note: The EUT doesn't have the telecommunication port.



3.6. Test Photographs

Front View



Rear View





4. Test of Radiated Emission

4.1. Test Limit

The EUT shall meet the limits of below Table when measured at the measuring distance R in accordance with the methods described in European Standard EN 55032. If the reading on the measuring receiver shows fluctuations close to the limit, the reading shall be observed for at least 15 s at each measurement frequency; the highest reading shall be recorded, with the exception of any brief isolated high reading, which shall be ignored.

Table 1 – Required highest frequency for radiated measurement

Highest internal frequency (F_x)	Highest measured frequency
$F_x \leq 108$ MHz	1 GHz
$108 \text{ MHz} < F_x \leq 500$ MHz	2 GHz
$500 \text{ MHz} < F_x \leq 1$ GHz	5 GHz
$F_x > 1$ GHz	$5 \times F_x$ up to a maximum of 6 GHz

NOTE 1 For FM and TV broadcast receivers, F_x is determined from the highest frequency generated or used excluding the local oscillator and tuned frequencies.

NOTE 2 F_x is defined in 3.1.19.

Where the F_x is unknown, the radiated emission measurements shall be performed up to 6 GHz.

Table A.2 – Requirements for radiated emissions at frequencies up to 1 GHz for Class A equipment

Table clause	Frequency range MHz	Measurement		Class A limits dB(μ V/m)
		Distance m	Detector type/ bandwidth	OATS/SAC (see Table A.1)
A2.1	30 – 230	10	Quasi Peak / 120 kHz	40
	230 – 1 000			47
A2.2	30 – 230	3		50
	230 – 1 000			57

NOTE Apply only A2.1 or A2.2 across the entire frequency range.

Table A.3 – Requirements for radiated emissions at frequencies above 1 GHz for Class A equipment

Table clause	Frequency range MHz	Measurement		Class A limits dB(μ V/m)
		Distance m	Detector type/ bandwidth	FSOATS (see Table A.1)
A3.1	1 000 – 3 000	3	Average / 1 MHz	56
	3 000 – 6 000			60
A3.2	1 000 – 3 000		Peak / 1 MHz	76
	3 000 – 6 000			80

NOTE Apply A3.1 and A3.2 across the frequency range from 1 000 MHz to the highest required frequency of measurement derived from Table 1.

**Table A.4 – Requirements for radiated emissions at frequencies up to 1 GHz for Class B equipment**

Table clause	Frequency range MHz	Measurement		Class B limits dB(μ V/m)
		Distance m	Detector type/ bandwidth	OATS/SAC (see Table A.1)
A4.1	30 – 230	10	Quasi Peak / 120 kHz	30
	230 – 1 000			37
A4.2	30 – 230	3		40
	230 – 1 000			47

NOTE Apply only table clause A4.1 or A4.2 across the entire frequency range.

Table A.5 – Requirements for radiated emissions at frequencies above 1 GHz for Class B equipment

Table clause	Frequency range MHz	Measurement		Class B limits dB(μ V/m)
		Distance m	Detector type/ bandwidth	FSOATS (see Table A.1)
A5.1	1 000 – 3 000	3	Average/ 1 MHz	50
	3 000 – 6 000			54
A5.2	1 000 – 3 000		Peak/ 1 MHz	70
	3 000 – 6 000			74

NOTE Apply A5.1 and A5.2 across the frequency range from 1 000 MHz to the highest required frequency of measurement derived from Table 1.

Table A.6 – Requirements for radiated emissions from FM receivers

Table clause	Frequency range MHz	Measurement		Class B limit dB(μ V/m)	
		Distance m	Detector type/ bandwidth	Fundamental	Harmonics
				OATS/SAC (see Table A.1)	OATS/SAC (see Table A.1)
A6.1	30 – 230	10	Quasi peak/ 120 kHz	50	42
	230 – 300				42
	300 – 1 000				46
A6.2	30 – 230	3		60	52
	230 – 300				52
	300 – 1 000				56

NOTE 1 Apply only A.6.1 or A.6.2 across the entire frequency range.

NOTE 2 These relaxed limits apply only to emissions at the fundamental and harmonic frequencies of the local oscillator. Signals at all other frequencies shall be compliant with the limits given in Table A.4.



Table A.12 – Requirements for conducted differential voltage emissions from Class B equipment

Applicable to						
1. TV broadcast receiver tuner ports (3.1.8) with an accessible connector						
2. RF modulator output ports (3.1.27)						
3. FM broadcast receiver tuner ports (3.1.8) with an accessible connector						
Table clause	Frequency range MHz	Detector type/ bandwidth	Class B limits dB(μV) 75 Ω			Applicability
			Other	Local Oscillator Fundamental	Local Oscillator Harmonics	
A12.1	30 – 950	For frequencies ≤1 GHz	46	46	46	See NOTE 1
	950 – 2 150		46	54	54	
A12.2	950 – 2 150	Quasi Peak/ 120 kHz	46	54	54	See NOTE 2
A12.3	30 – 300		For frequencies ≥1 GHz	46	54	50
	300 – 1 000	52				
A12.4	30 – 300	Peak/ 1 MHz	46	66	59	See NOTE 4
	300 – 1 000				52	
A12.5	30 – 950	Peak/ 1 MHz	46	76	46	See NOTE 5
	950 – 2 150			n/a	54	

NOTE 1 Television receivers (analogue or digital), video recorders and PC TV broadcast receiver tuner cards working in channels between 30 MHz and 1 GHz, and digital audio receivers.

NOTE 2 Tuner units (not the LNB) for satellite signal reception.

NOTE 3 Frequency modulation audio receivers and PC tuner cards.

NOTE 4 Frequency modulation car radios.

NOTE 5 Applicable to EUTs with RF modulator output ports (for example DVD equipment, video recorders, camcorders and decoders etc.) designed to connect to TV broadcast receiver tuner ports.

NOTE 6 Testing is required at only one EUT supply voltage and frequency.

NOTE 7 The term 'other' refers to all emissions other than the fundamental and the harmonics of the local oscillator.

NOTE 8 The test shall be performed with the device operating at each reception channel.

NOTE 9 The test shall cover the entire frequency range.

4.2. Test Procedures

The EUT was placed on a rotatable table top 0.8 meter above ground.

The EUT was set 3/10 meters from the interference receiving antenna which was mounted on the top of a variable height antenna tower.

The table was rotated 360 degrees to determine the position of the highest radiation.

The antenna is a half wave dipole and its height is varied between one meter and four meters above ground to find the maximum value of the field strength both horizontal polarization and vertical polarization of the antenna are set to make the measurement.

For each suspected emission the EUT was arranged to its worst case and then tune the antenna tower (from 1 M to 4 M) and turn table (from 0 degree to 360 degrees) to find the maximum reading.

Set the test-receiver system to Peak Detect Function and specified bandwidth with Maximum Hold Mode.

If the emission level of the EUT in peak mode was 3 dB lower than the limit specified, then testing will be stopped and peak values of EUT will be reported, otherwise, the emissions which do not have 3 dB margin will be repeated one by one using the quasi-peak method and reported.

4.3. Typical Test Setup

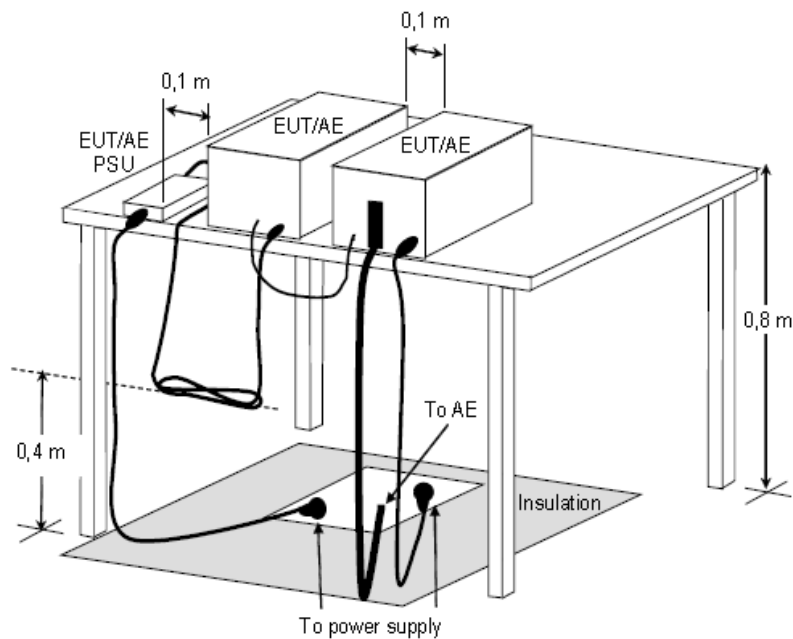

Figure D.8 – Example measurement arrangement for table-top EUT
(Radiated emission measurement)



4.4. Measurement Equipment

Instrument/Ancillary	Manufacturer	Model No.	Serial No.	Calibration Date	Valid Date.
EMI Test Receiver	R&S	ESC17	100968	2016.07.21	2017.07.20
Preamplifier	Agilent	87405B	My39500554	2016.03.26	2017.03.25
Preamplifier	Agilent	8449B	3008A02342	2016.03.26	2017.03.25
Bilog Antenna	Sunol Science	JB1	A072414-1	2016.04.16	2017.04.15
Broad-Band Horn Antenna	Schwarzbeck	BBHA9120D	9120D-618	2016.04.16	2017.04.15
Spectrum Analyzer	R&S	FSP40	100324	2016.08.02	2017.08.01
Temperature/ Humidity Meter	Zhicheng	ZC1-11	CEP-TH-001	2016.03.29	2017.03.28
EZ-EMC	Fala	Ver CT3A1	N/A	N/A	N/A



4.5. Test Result and Data (30MHz ~ 1000MHz)

Test Mode :	Mode 1: Full system (DVI mode 3840*2160@30Hz) with adapter 1 (110V/60Hz)		
AC Power :	AC 110V/60Hz	Ant. Polarization:	Horizontal
Equipment :	LCD Monitor	Model No :	280LM00004
Temperature :	21°C	Humidity :	53%
Pressure(mbar) :	1001	Date:	2017/02/22

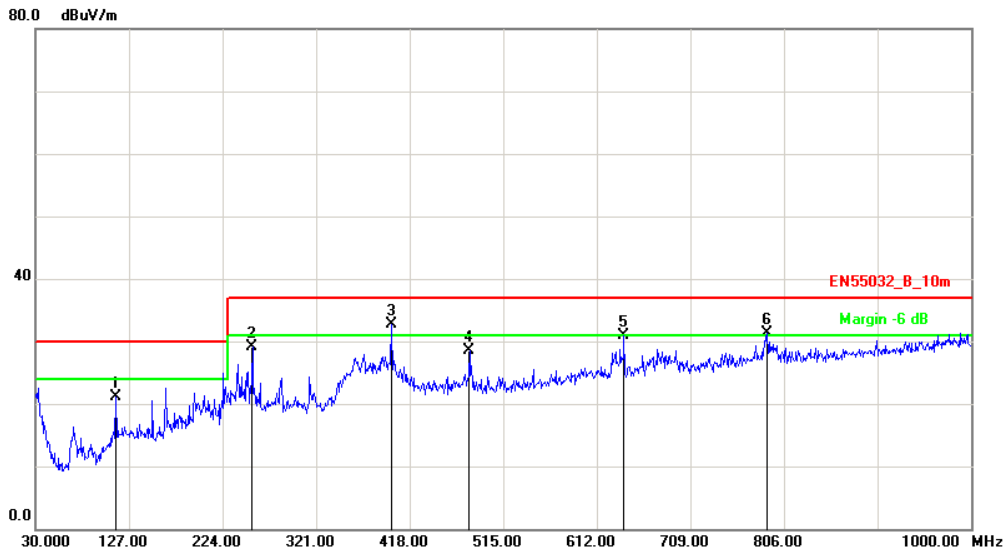

No.	Frequency (MHz)	Factor (dB/m)	Reading (dBuV)	Level (dBuV/m)	Limit (dBuV/m)	Margin (dB)	Det.	Height (cm)	Azimuth (deg)
1	113.4200	-10.95	32.02	21.07	30.00	-8.93	peak	400	134
2	255.0399	-10.24	39.34	29.10	37.00	-7.90	peak	300	57
3	398.6000	-5.34	38.07	32.73	37.00	-4.27	peak	300	118
4	480.0799	-3.66	32.07	28.41	37.00	-8.59	peak	200	38
5	640.1299	-0.53	31.34	30.81	37.00	-6.19	peak	100	0
6	788.5399	1.91	29.33	31.24	37.00	-5.76	peak	100	324

Note: Measurement Level = Reading Level + Correct Factor



Test Mode :	Mode 1: Full system (DVI mode 3840*2160@30Hz) with adapter 1 (110V/60Hz)		
AC Power :	AC 110V/60Hz	Ant. Polarization:	Vertical
Equipment :	LCD Monitor	Model No :	280LM00004
Temperature :	21°C	Humidity :	53%
Pressure(mbar) :	1001	Date:	2017/02/22

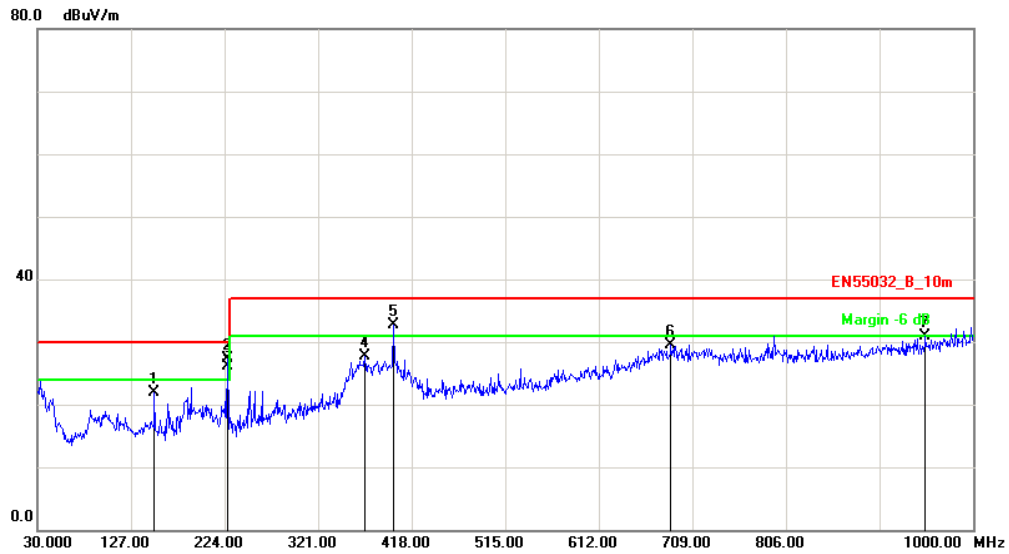

No.	Frequency (MHz)	Factor (dB/m)	Reading (dBuV)	Level (dBuV/m)	Limit (dBuV/m)	Margin (dB)	Det.	Height (cm)	Azimuth (deg)
1	151.2500	-10.67	32.66	21.99	30.00	-8.01	peak	100	333
2	226.9100	-11.56	38.94	27.38	30.00	-2.62	peak	100	21
3	227.4000	-11.53	37.51	25.98	30.00	-4.02	QP	100	38
4	369.5000	-6.61	34.28	27.67	37.00	-9.33	peak	100	144
5	398.6000	-5.34	37.97	32.63	37.00	-4.37	peak	100	337
6	686.6900	-0.15	29.61	29.46	37.00	-7.54	peak	300	277
7	950.5300	4.14	26.82	30.96	37.00	-6.04	peak	400	71

Note: Measurement Level = Reading Level + Correct Factor



Test Mode :	Mode 2: Full system (DVI mode 3840*2160@30Hz) with adapter 1 (230V/50Hz)		
AC Power :	AC 230V/50Hz	Ant. Polarization:	Horizontal
Equipment :	LCD Monitor	Model No :	280LM00004
Temperature :	21°C	Humidity :	53%
Pressure(mbar) :	1001	Date:	2017/02/22

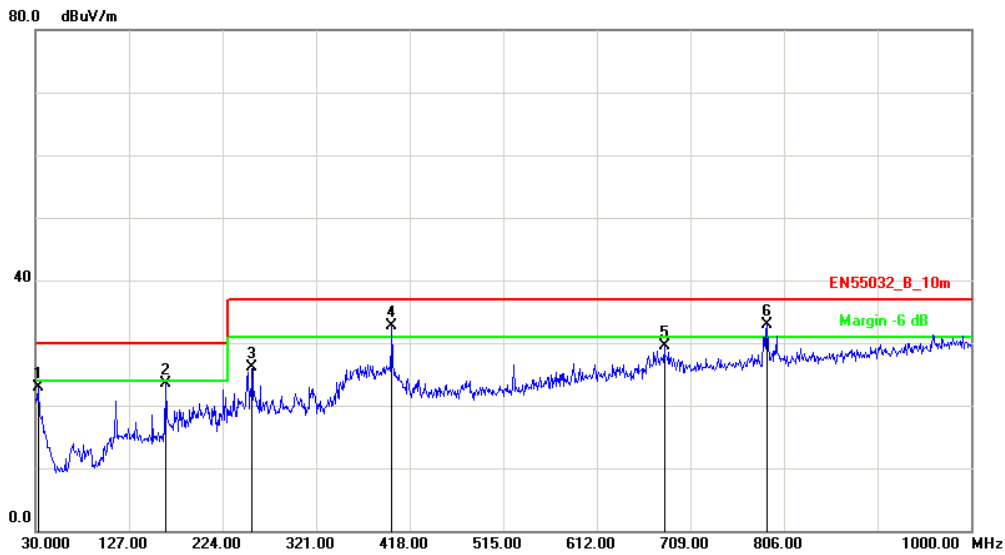

No.	Frequency (MHz)	Factor (dB/m)	Reading (dBuV)	Level (dBuV/m)	Limit (dBuV/m)	Margin (dB)	Det.	Height (cm)	Azimuth (deg)
1	32.9099	-5.36	28.19	22.83	30.00	-7.17	peak	100	20
2	164.8300	-11.01	34.49	23.48	30.00	-6.52	peak	400	269
3	255.0399	-10.24	36.28	26.04	37.00	-10.96	peak	400	70
4	399.5699	-5.28	38.04	32.76	37.00	-4.24	peak	200	219
5	681.8400	-0.14	29.66	29.52	37.00	-7.48	peak	100	49
6	788.5399	1.91	31.07	32.98	37.00	-4.02	peak	400	202

Note: Measurement Level = Reading Level + Correct Factor



Test Mode :	Mode 2: Full system (DVI mode 3840*2160@30Hz) with adapter 1 (230V/50Hz)		
AC Power :	AC 230V/50Hz	Ant. Polarization:	Vertical
Equipment :	LCD Monitor	Model No :	280LM00004
Temperature :	21°C	Humidity :	53%
Pressure(mbar) :	1001	Date:	2017/02/22

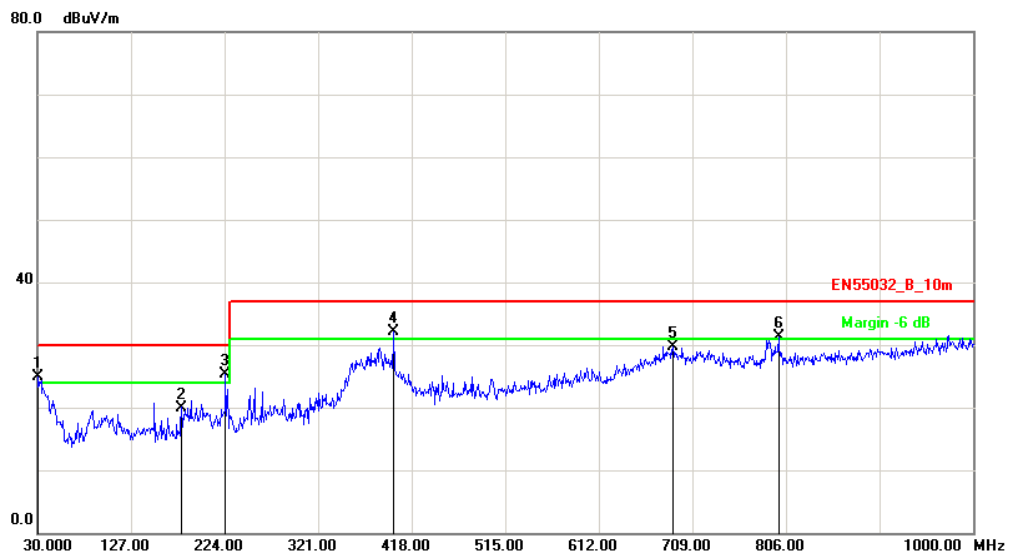

No.	Frequency (MHz)	Factor (dB/m)	Reading (dBuV)	Level (dBuV/m)	Limit (dBuV/m)	Margin (dB)	Det.	Height (cm)	Azimuth (deg)
1	30.9700	-3.96	28.85	24.89	30.00	-5.11	peak	100	92
2	179.3800	-11.46	31.46	20.00	30.00	-10.00	peak	100	151
3	224.9700	-11.66	36.87	25.21	30.00	-4.79	peak	100	139
4	399.5700	-5.28	37.29	32.01	37.00	-4.99	peak	100	32
5	688.6300	-0.16	29.84	29.68	37.00	-7.32	peak	300	304
6	798.2400	2.04	29.18	31.22	37.00	-5.78	peak	299	0

Note: Measurement Level = Reading Level + Correct Factor



4.6. Test Result and Data (1000MHz ~ 6000MHz)

Test Mode :	Mode 1: Full system (HDMI mode 3840*2160@30Hz) with adapter 1 (110V/60Hz)		
AC Power :	AC 110V/60Hz	Ant. Polarization:	Horizontal
Equipment :	LCD Monitor	Model No :	280LM00004
Temperature :	21°C	Humidity :	53%
Pressure(mbar) :	1001	Date:	2017/02/22

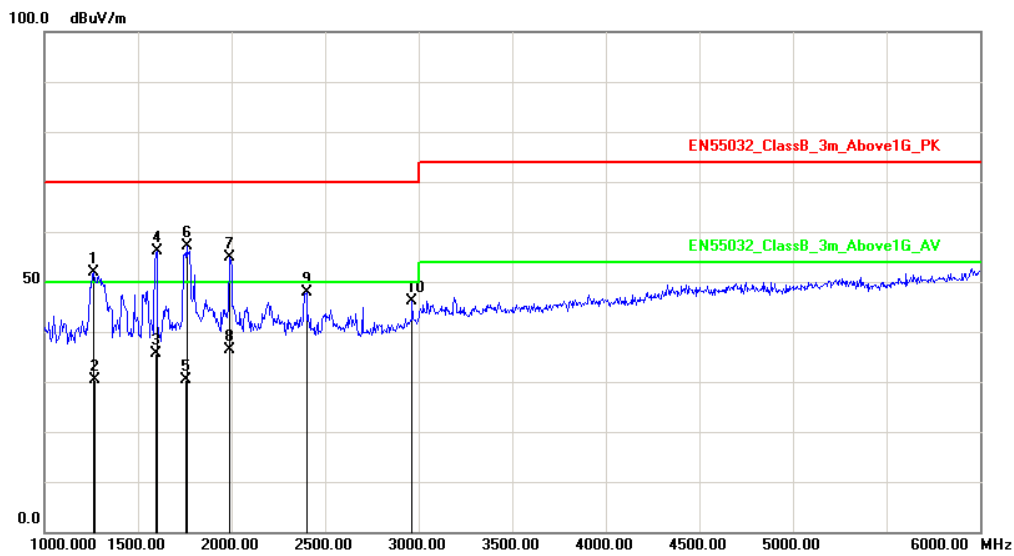

No.	Frequency (MHz)	Factor (dB/m)	Reading (dBuV)	Level (dBuV/m)	Limit (dBuV/m)	Margin (dB)	Det.	Height (cm)	Azimuth (deg)
1	1265.000	-4.21	56.21	52.00	70.00	-18.00	peak	121	360
2	1267.310	-4.19	34.64	30.45	50.00	-19.55	AVG	120	360
3	1599.200	-2.35	37.96	35.61	50.00	-14.39	AVG	100	259
4	1600.000	-2.35	58.49	56.14	70.00	-13.86	peak	100	266
5	1759.996	-1.89	32.16	30.27	50.00	-19.73	AVG	100	333
6	1760.000	-1.89	58.91	57.02	70.00	-12.98	peak	100	326
7	1990.000	-1.23	56.05	54.82	70.00	-15.18	peak	100	310
8	1990.310	-1.23	37.68	36.45	50.00	-13.55	AVG	100	316
9	2400.000	0.84	46.99	47.83	70.00	-22.17	peak	100	10
10	2965.000	3.93	42.18	46.11	70.00	-23.89	peak	100	54

Note: Measurement Level = Reading Level + Correct Factor



Test Mode :	Mode 1: Full system (HDMI mode 3840*2160@30Hz) with adapter 1 (110V/60Hz)		
AC Power :	AC 110V/60Hz	Ant. Polarization:	Vertical
Equipment :	LCD Monitor	Model No :	280LM00004
Temperature :	21°C	Humidity :	53%
Pressure(mbar) :	1001	Date:	2017/02/22

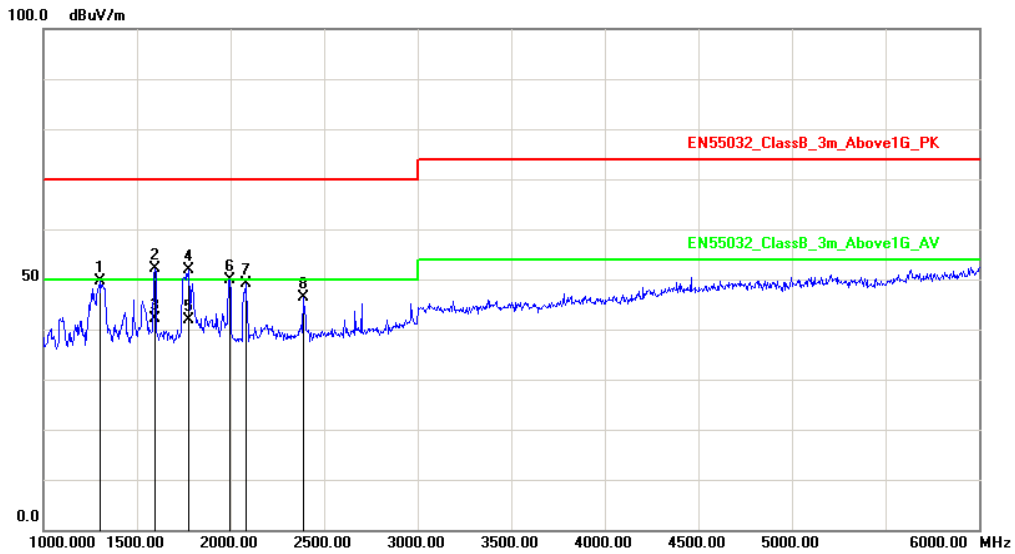

No.	Frequency (MHz)	Factor (dB/m)	Reading (dBuV)	Level (dBuV/m)	Limit (dBuV/m)	Margin (dB)	Det.	Height (cm)	Azimuth (deg)
1	1300.000	-3.98	53.56	49.58	70.00	-20.42	peak	100	70
2	1595.000	-2.37	54.55	52.18	70.00	-17.82	peak	123	0
3	1598.310	-2.36	44.51	42.15	50.00	-7.85	AVG	120	0
4	1775.000	-1.85	53.63	51.78	70.00	-18.22	peak	200	63
5	1778.640	-1.84	43.62	41.78	50.00	-8.22	AVG	200	70
6	1995.000	-1.21	51.11	49.90	70.00	-20.10	peak	200	319
7	2080.000	-0.79	49.83	49.04	70.00	-20.96	peak	100	54
8	2390.000	0.79	45.61	46.40	70.00	-23.60	peak	200	35

Note: Measurement Level = Reading Level + Correct Factor



Test Mode :	Mode 2: Full system (HDMI mode 3840*2160@30Hz) with adapter 1 (230V/50Hz)		
AC Power :	AC 230V/50Hz	Ant. Polarization:	Horizontal
Equipment :	LCD Monitor	Model No :	280LM00004
Temperature :	21°C	Humidity :	53%
Pressure(mbar) :	1001	Date:	2017/02/22

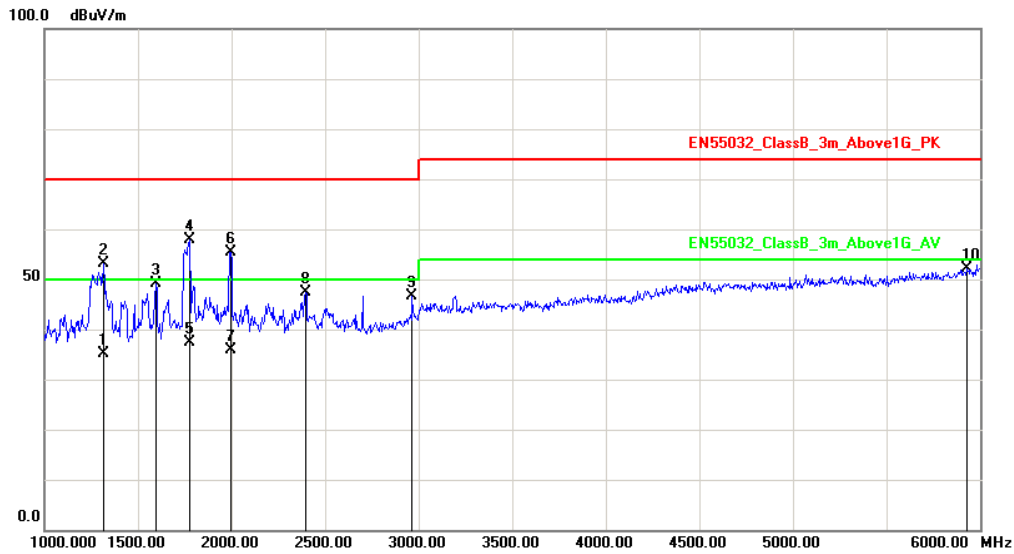

No.	Frequency (MHz)	Factor (dB/m)	Reading (dBuV)	Level (dBuV/m)	Limit (dBuV/m)	Margin (dB)	Det.	Height (cm)	Azimuth (deg)
1	1314.610	-3.88	39.01	35.13	50.00	-14.87	AVG	200	310
2	1315.000	-3.88	57.07	53.19	70.00	-16.81	peak	200	306
3	1595.000	-2.37	51.39	49.02	70.00	-20.98	peak	100	54
4	1775.000	-1.85	59.84	57.99	70.00	-12.01	peak	100	318
5	1775.000	-1.85	39.16	37.31	50.00	-12.69	AVG	100	320
6	1995.000	-1.21	56.56	55.35	70.00	-14.65	peak	100	318
7	1995.000	-1.21	37.15	35.94	50.00	-14.06	AVG	100	321
8	2395.000	0.81	46.47	47.28	70.00	-22.72	peak	100	33
9	2965.000	3.93	42.69	46.62	70.00	-23.38	peak	100	51
10	5930.000	13.94	38.24	52.18	74.00	-21.82	peak	200	154

Note: Measurement Level = Reading Level + Correct Factor



Test Mode :	Mode 2: Full system (HDMI mode 3840*2160@30Hz) with adapter 1 (230V/50Hz)		
AC Power :	AC 230V/50Hz	Ant. Polarization:	Vertical
Equipment :	LCD Monitor	Model No :	280LM00004
Temperature :	21°C	Humidity :	53%
Pressure(mbar) :	1001	Date:	2017/02/22

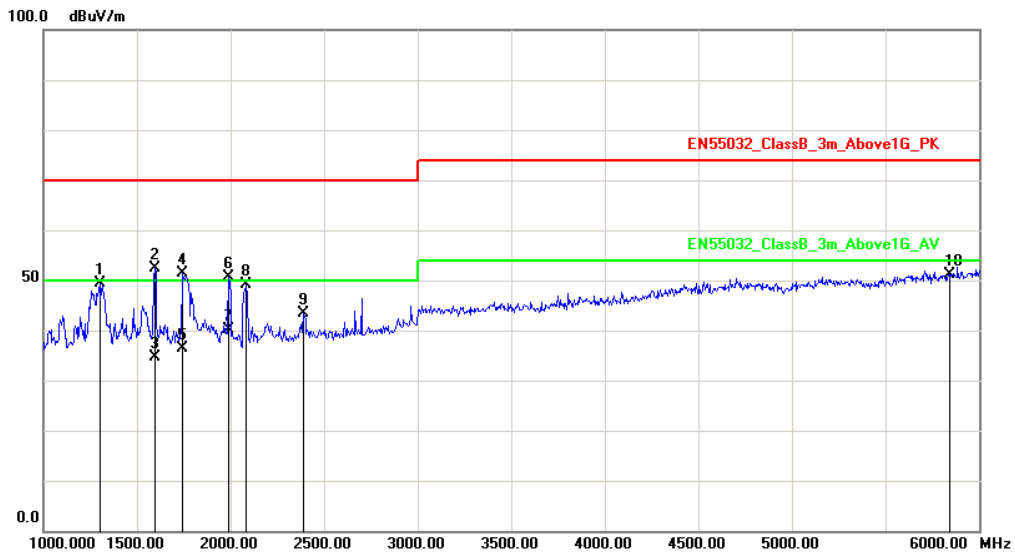

No.	Frequency (MHz)	Factor (dB/m)	Reading (dBuV)	Level (dBuV/m)	Limit (dBuV/m)	Margin (dB)	Det.	Height (cm)	Azimuth (deg)
1	1300.000	-3.98	53.48	49.50	70.00	-20.50	peak	100	324
2	1595.000	-2.37	54.66	52.29	70.00	-17.71	peak	200	0
3	1598.640	-2.36	36.97	34.61	50.00	-15.39	AVG	200	2
4	1745.000	-1.93	53.32	51.39	70.00	-18.61	peak	200	51
5	1746.310	-1.93	38.35	36.42	50.00	-13.58	AVG	200	60
6	1990.000	-1.23	51.98	50.75	70.00	-19.25	peak	200	246
7	1992.460	-1.22	41.35	40.13	50.00	-9.87	AVG	200	251
8	2085.000	-0.77	49.79	49.02	70.00	-20.98	peak	100	50
9	2390.000	0.79	42.51	43.30	70.00	-26.70	peak	200	38
10	5840.000	13.57	37.56	51.13	74.00	-22.87	peak	200	0

Note: Measurement Level = Reading Level + Correct Factor

Test engineer: *Sun Zhang*



4.7. Test Photographs (30MHz ~ 1000MHz)

Front View



Rear View

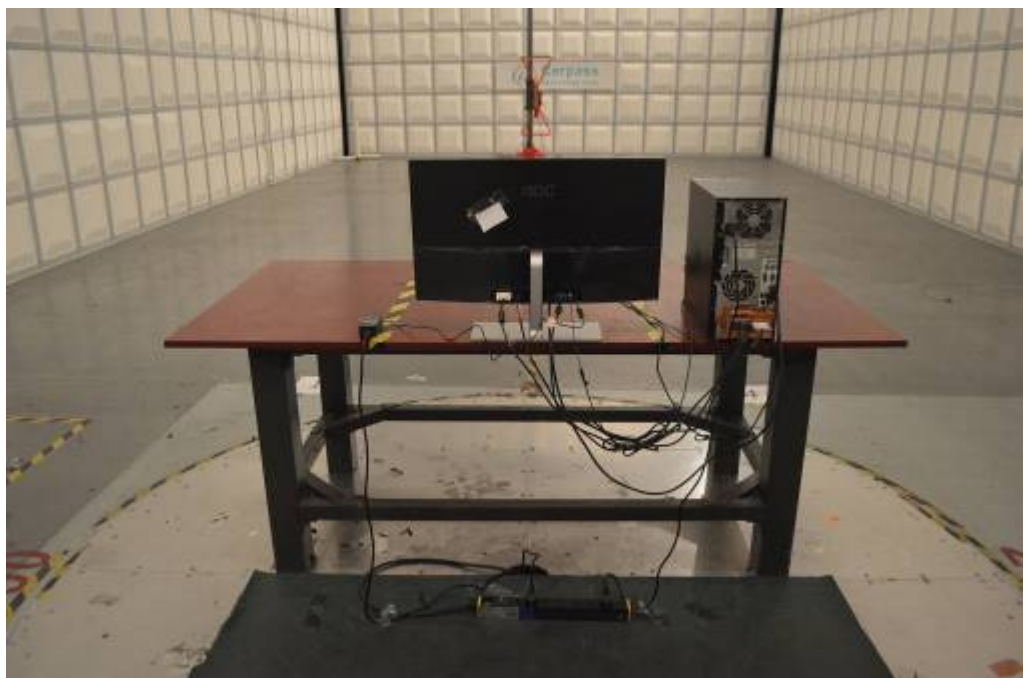



4.8. Test Photographs (1000MHz ~ 6000MHz)

Front View



Rear View

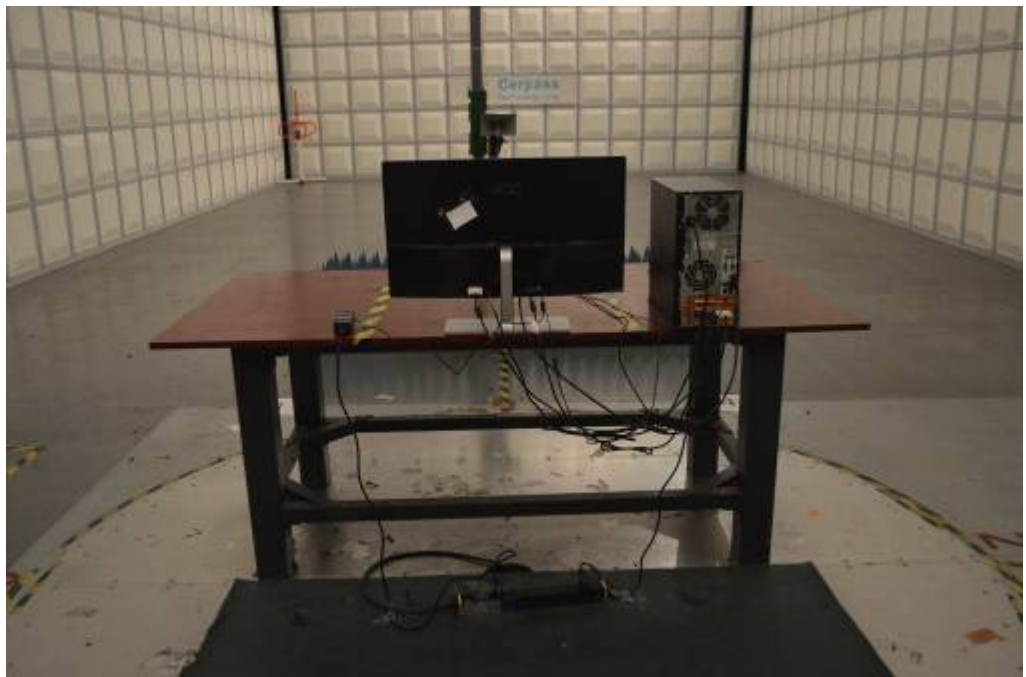



5. Harmonics Test

5.1. Limits of Harmonics Current Measurement

Limits for Class A equipment

Harmonics Order n	Max. permissible harmonics current A	Harmonics Order n	Max. permissible harmonics current A
Odd harmonics		Even harmonics	
3	2.30	2	1.08
5	1.14	4	0.43
7	0.77	6	0.30
9	0.40	8<=n<=40	0.23x8/n
11	0.33		
13	0.21		
15<=n<=39	0.15x15/n		

(b) Limits for Class B equipment

For Class B equipment, the harmonics of the input current shall not exceed the values given in Table that is the limit of Class A multiplied by a factor of 1,5.

(c) Limits for Class C equipment

Harmonics Order n	Maximum permissible harmonic current expressed as a percentage of the input current at the fundamental frequency %
2	2
3	$30 \cdot \lambda^*$
5	10
7	7
9	5
11<n<39 (odd harmonics only)	3

* λ is the circuit power factor

(d) Limits for Class D equipment

Harmonics Order n	Maximum permissible harmonic current per watt mA/W	Maximum permissible harmonic current A
3	3.4	2.30
5	1.9	1.14
7	1.0	0.77
9	0.5	0.40
11	0.35	0.33
11 < n < 39 (odd harmonics only)	3.85/n	See limit of Class A

NOTE: According to section 7 of EN 61000-3-2, the above limits for all equipment except for lighting equipment having an active input power > 75 W and no limits apply for equipment with an active input power up to and including 75 W.



5.2. Measurement Equipment

Instrument/Ancillary	Manufacturer	Model No.	Serial No.	Calibration Date	Valid Date.
EMC Emission Tester	EMCPARTNER	Harmonics-1000	159	2015.04.02	2016.04.01
Temperature/ Humidity Meter	Zhicheng	ZC1-11	CEP-TH-004	2015.04.02	2016.04.01
HARCS	EMC Partner AG	Ver 4.18	N/A	N/A	N/A



5.3. Test Result and Data

Basic Standard	:	EN 61000-3-2
Final Test Result	:	PASS
Test Mode	:	Mode 1, 2, 3, 4
Model No.	:	280LM00004
Temperature	:	23°C
Humidity	:	54%
Atmospheric Pressure	:	100 kPa
Test Date	:	Sep 18, 2015

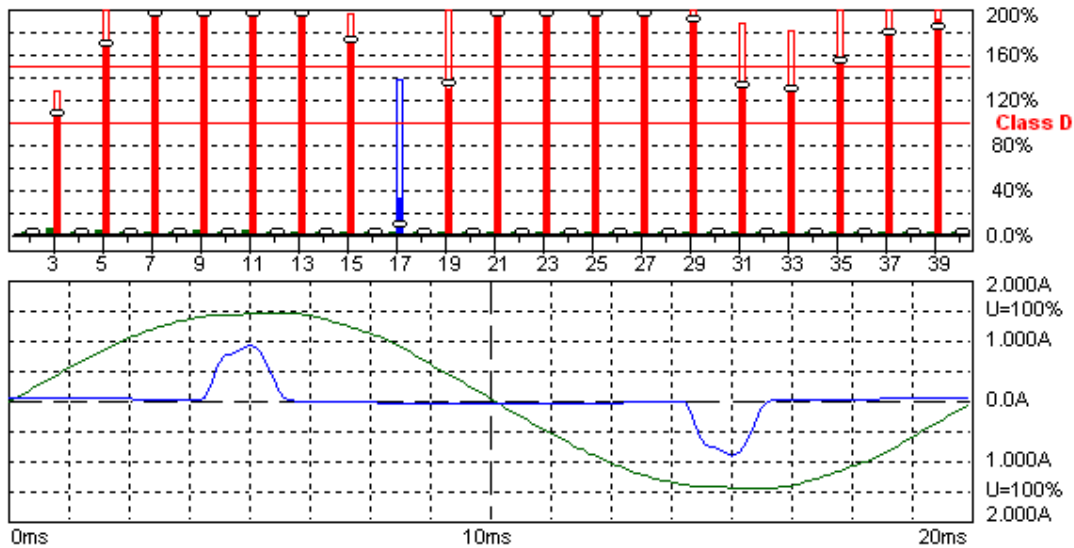

Harmonic Emission - IEC 61000-3-2 , EN 61000-3-2 , (EN60555-2)

2015-9-18 10:33:30 harmonic.hsu

Urms = 230.1 V	P = 30.68 W	THC = 0.229 A	Range: 2 A
Irms = 0.268 A	pf = 0.498	Pmax = 36.10 W	V-nom: 230 V
			TestTime: 15 min (100%)

HAR-1000 EMC-Partner

Urms = 229.9V Freq = 50.000 Range: 2 A
 Irms = 0.297A Ipk = 1.027A cf = 3.461
 P = 35.10W S = 68.26VA pf = 0.514
 THDi = 84.4 % THDu = 1.90 % Class D
 Test - Time : 15min (100 %)
 Limit Reference: Pmax = 41.361W
 Test completed



Order	Freq. [Hz]	Irms [A]	Irms%L [%]	I _{max} [A]	I _{max} %L [%]	Limit [A]	Status
1	50	0.1620		0.1627			
2	100	0.0112		0.0117			
3	150	0.1483	105.47	0.1489	105.90	0.00	N/L
4	200	0.0103		0.0106			
5	250	0.1313	167.14	0.1320	167.92	0.00	N/L
6	300	0.0087		0.0090			
7	350	0.1097	265.33	0.1107	267.69	0.00	N/L
8	400	0.0061		0.0063			
9	450	0.0833	402.56	0.0847	409.65	0.00	N/L
10	500	0.0035		0.0038			
11	550	0.0549	379.46	0.0568	392.11	0.00	N/L
12	600	0.0017		0.0020			
13	650	0.0308	251.13	0.0327	267.08	0.00	N/L
14	700	0.0009		0.0011			
15	750	0.0094	88.540	0.0114	106.94	0.00	N/L
16	800	0.0022		0.0023			
17	850	0.0066	70.372	0.0078	83.404	0.00	N/L
18	900	0.0031		0.0032			
19	950	0.0168	201.00	0.0176	209.74	0.00	N/L
20	1000	0.0035		0.0037			
21	1050	0.0217	286.55	0.0221	291.38	0.00	N/L
22	1100	0.0034		0.0035			
23	1150	0.0220	317.37	0.0223	322.66	0.00	N/L
24	1200	0.0032		0.0033			
25	1250	0.0187	293.22	0.0193	302.80	0.00	N/L
26	1300	0.0029		0.0031			
27	1350	0.0135	229.75	0.0143	242.16	0.00	N/L
28	1400	0.0027		0.0027			
29	1450	0.0079	144.50	0.0087	157.84	0.00	N/L
30	1500	0.0023		0.0026			
31	1550	0.0042	80.798	0.0046	90.304	0.00	N/L
32	1600	0.0021		0.0022			
33	1650	0.0040	83.481	0.0046	96.130	0.00	N/L
34	1700	0.0017		0.0018			
35	1750	0.0049	107.32	0.0054	118.05	0.00	N/L
36	1800	0.0013		0.0015			
37	1850	0.0049	113.45	0.0051	119.13	0.00	N/L
38	1900	0.0011		0.0011			
39	1950	0.0038	92.680	0.0040	98.659	0.00	N/L
40	2000	0.0009		0.0009			

The power of EUT is less than 75W after the testing. According the standard, the equipment with a rated power of 75W or less, other than lighting equipment, limits are not specified in this standard. So the test data needn't list.



Basic Standard	:	EN 61000-3-2
Final Test Result	:	PASS
Test Mode	:	Mode 5, 6, 7, 8
Model No.	:	280LM00004
Temperature	:	23°C
Humidity	:	54%
Atmospheric Pressure	:	100 kPa
Test Date	:	Sep 18, 2015

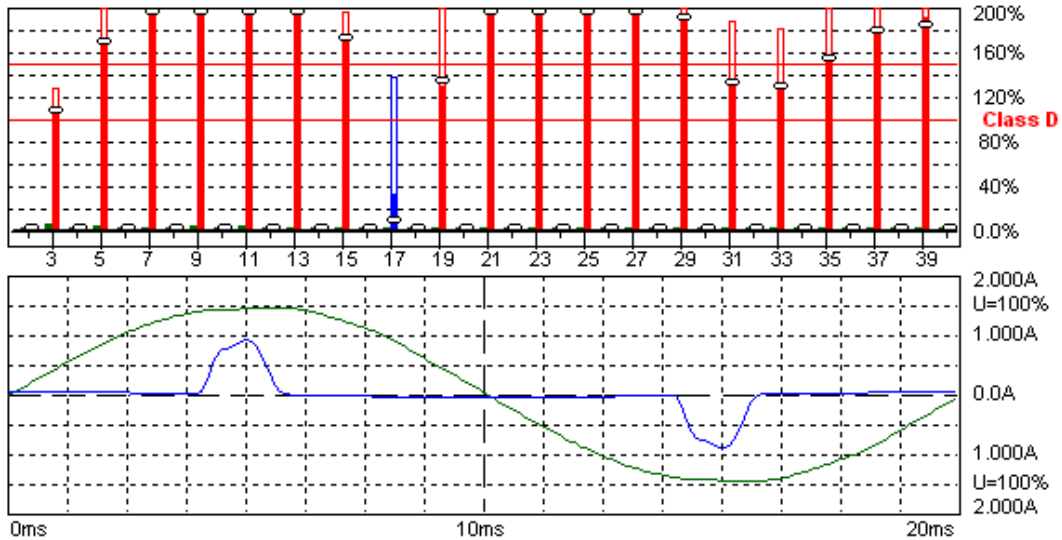

Harmonic Emission - IEC 61000-3-2 , EN 61000-3-2 , (EN60555-2)

2015-9-18 11:23:30 harmonic.hsu

Urms = 230.1 V	P = 30.68 W	THC = 0.229 A	Range: 2 A
Irms = 0.268 A	pf = 0.498	Pmax = 36.10 W	V-nom: 230 V
			TestTime: 15 min (100%)

HAR-1000 EMC-Partner

Urms = 229.9V Freq = 49.987 Range: 2 A
 Irms = 0.303A Ipk = 1.107A cf = 3.658
 P = 35.54W S = 69.60VA pf = 0.511
 THDi = 85.1 % THDu = 2.00 % Class D
 Test - Time : 15min (100 %)
 Limit Reference: Pmax = 35.971W
 Test completed



Order	Freq. [Hz]	Irms [A]	Irms%L [%]	I _{max} [A]	I _{max} %L [%]	Limit [A]	Status
1	50	0.1620		0.1638			
2	100	0.0146		0.0150			
3	150	0.1505	123.07	0.1521	124.36	0.00	N/L
4	200	0.0129		0.0132			
5	250	0.1343	196.47	0.1359	198.79	0.00	N/L
6	300	0.0106		0.0107			
7	350	0.1130	314.24	0.1145	318.31	0.00	N/L
8	400	0.0077		0.0078			
9	450	0.0873	485.28	0.0887	493.42	0.00	N/L
10	500	0.0044		0.0045			
11	550	0.0598	475.09	0.0614	487.70	0.00	N/L
12	600	0.0017		0.0018			
13	650	0.0356	334.59	0.0374	350.64	0.00	N/L
14	700	0.0013		0.0015			
15	750	0.0145	157.34	0.0162	175.85	0.00	N/L
16	800	0.0024		0.0027			
17	850	0.0054	65.931	0.0063	77.919	0.00	N/L
18	900	0.0029		0.0031			
19	950	0.0142	194.27	0.0150	205.99	0.00	N/L
20	1000	0.0029		0.0031			
21	1050	0.0193	292.46	0.0197	298.01	0.00	N/L
22	1100	0.0024		0.0026			
23	1150	0.0199	330.45	0.0205	340.59	0.00	N/L
24	1200	0.0020		0.0021			
25	1250	0.0168	304.10	0.0177	319.52	0.00	N/L
26	1300	0.0022		0.0023			
27	1350	0.0120	233.23	0.0129	252.27	0.00	N/L
28	1400	0.0029		0.0032			
29	1450	0.0074	155.93	0.0083	173.82	0.00	N/L
30	1500	0.0035		0.0037			
31	1550	0.0062	139.36	0.0068	153.02	0.00	N/L
32	1600	0.0038		0.0039			
33	1650	0.0081	191.98	0.0084	200.70	0.00	N/L
34	1700	0.0034		0.0035			
35	1750	0.0094	237.55	0.0096	243.72	0.00	N/L
36	1800	0.0028		0.0029			
37	1850	0.0094	251.12	0.0096	257.64	0.00	N/L
38	1900	0.0021		0.0022			
39	1950	0.0079	223.44	0.0082	230.32	0.00	N/L
40	2000	0.0015		0.0017			

The power of EUT is less than 75W after the testing. According the standard, the equipment with a rated power of 75W or less, other than lighting equipment, limits are not specified in this standard. So the test data needn't list.

Test engineer: Seben



5.4. Test Photographs





6. Voltage Fluctuations Test

6.1. Test Procedure

The equipment shall be tested under the conditions of **Clause 5**.

The total impedance of the test circuit, excluding the appliance under test, but including the internal impedance of the supply source, shall be equal to the reference impedance.

The stability and tolerance of the reference impedance shall be adequate to ensure that the overall accuracy of $\pm 8\%$ is achieved during the whole assessment procedure.

6.2. Measurement Equipment

Instrument/Ancillary	Manufacturer	Model No.	Serial No.	Calibration Date	Valid Date.
EMC Emission Tester	EMCPARTNER	Harmonics-1000	159	2015.04.02	2016.04.01
Temperature/ Humidity Meter	Zhicheng	ZC1-11	CEP-TH-004	2015.04.02	2016.04.01
HARCS	EMC Partner AG	Ver 4.18	N/A	N/A	N/A



6.3. Test Result and Data

Basic Standard	:	EN 61000-3-3
Final Test Result	:	PASS
Test Mode	:	Mode 1, 2, 3, 4
Model No.	:	280LM00004
Temperature	:	23°C
Humidity	:	54%
Atmospheric Pressure	:	100 kPa
Test Date	:	Sep 18, 2015

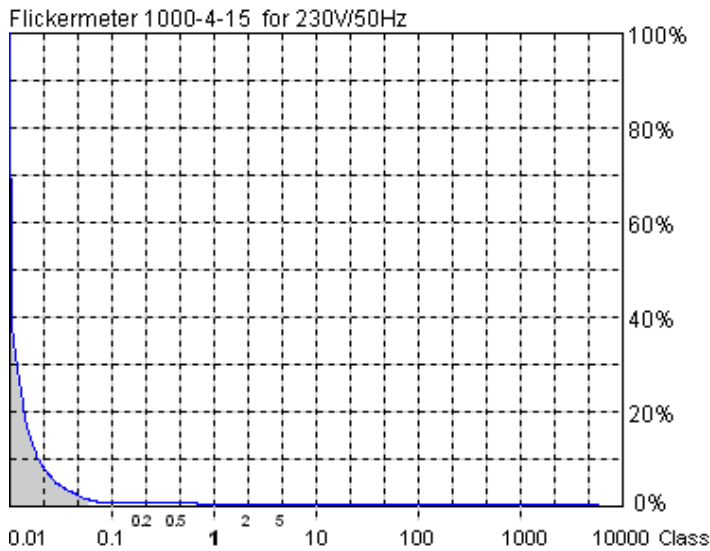

Actual Flicker (Fli): 0.01
Short-term Flicker (Pst): 0.24
 Limit (Pst): 1.00
Long-term Flicker (Plt): 0.24
 Limit (Plt): 0.65
Maximum Relative Volt. Change (dmax): 0.01%
 Limit (dmax): 4.00%
Relative Steady-state Voltage Change (dc): 0.15%
 Limit (dc): 3.30%
Maximum Interval exceeding 3.30% (dt): 0.00ms
 Limit (dt>Lim): 500ms

Flicker Emission - IEC 61000-3-3 , EN 61000-3-3 , (EN60555-3)

Urms = 229.9 V P = 34.70 W
 Irms = 0.295 A pf = 0.512

280LM00004

Test completed, Result: PASSED

2015-9-18 11:02:59 harmonic.hsu

Range: 2 A
 V-nom: 230 V
 TestTime: 10 min (100%)

HAR-1000 EMC-Parber

Full Bar : Actual Values

Empty Bar : Maximum Values

Circles : Average Values

Blue : Current , Green : Voltage , Red : Failed



Urms = 229.9V Freq = 50.000 Range: 2 A
Irms = 0.295A Ipk = 0.992A cf = 3.364
P = 34.70W S = 67.81VA pf = 0.512

Test - Time : 1 x 10min = 10min (100 %)

LIN (Line Impedance Network) : No LIN

Limits : Plt : 0.65 Pst : 1.00
dmax : 4.00 % dc : 3.30 %
dtLim: 3.30 % dt>Lim: 500ms

Test completed, Result: PASSED



Basic Standard	:	EN 61000-3-3
Final Test Result	:	PASS
Test Mode	:	Mode 5, 6, 7, 8
Model No.	:	280LM00004
Temperature	:	23°C
Humidity	:	54%
Atmospheric Pressure	:	100 kPa
Test Date	:	Sep 18, 2015

Flickermeter 1000-4-15 for 230V/50Hz

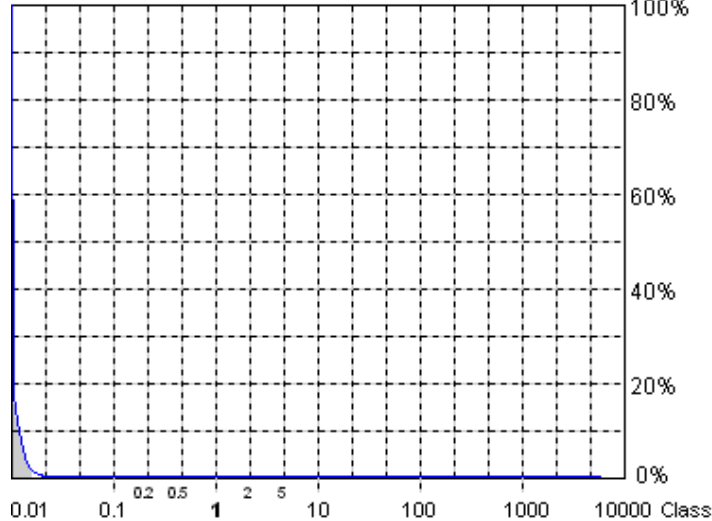

Actual Flicker (Fli): 0.01
Short-term Flicker (Pst): 0.08
 Limit (Pst): 1.00
Long-term Flicker (Plt): 0.08
 Limit (Plt): 0.65
Maximum Relative Volt. Change (dmax): 0.00%
 Limit (dmax): 4.00%
Relative Steady-state Voltage Change (dc): 0.11%
 Limit (dc): 3.30%
Maximum Interval exceeding 3.30% (dt): 0.00ms
 Limit (dt>Lim): 500ms

Flicker Emission - IEC 61000-3-3 , EN 61000-3-3 , (EN60555-3)

Urms = 229.9 V P = 35.24 W
 Irms = 0.301 A pf = 0.510

280LM00004

Test completed, Result: PASSED

2015-9-18 10:20:21 harmonic.hsu

Range: 2 A
 V-nom: 230 V
 TestTime: 10 min (100%)

HAR-1000 EMC-Partner

Full Bar : Actual Values

Empty Bar : Maximum Values

Circles : Average Values

Blue : Current , Green : Voltage , Red : Failed



Urms = 229.9V Freq = 50.000 Range: 2 A
Irms = 0.301A Ipk = 1.105A cf = 3.675
P = 35.24W S = 69.15VA pf = 0.510

Test - Time : 1 x 10min = 10min (100 %)

LIN (Line Impedance Network) : No LIN

Limits : PIt : 0.65 Pst : 1.00
dmax : 4.00 % dc : 3.30 %
dtLim: 3.30 % dt>Lim: 500ms

Test completed, Result: PASSED

Test engineer: 



6.4. Test Photographs





7. Photographs of EUT

1) EUT Photo



2) EUT Photo





3) EUT Photo



4) EUT Photo





5) EUT Photo



6) EUT Photo(Adapter #1)





7) EUT Photo



8) EUT Photo





9) EUT Photo



10) EUT Photo(Adapter #2)





11) EUT Photo



12) EUT Photo



AC ADAPTER 电源适配器 / 电源供应器
 TPV ELECTRONICS(FUJIAN) CO., LTD
 MODEL (型号 / 型号): ADPC2065
 INPUT (输入 / 输入): 100-240V ~ 1.5A 50-60Hz
 OUTPUT (输出 / 输出): DC20V = 3.25A

ATTENTION

Laitte on tillettävä suojakosketimilla varustettuun pistorasiaan.
 Apparatet må tilkoples jordat stikkontakt.
 Apparatet skall anslutas till jordat uttag.
 The equipment must be connected to an earthed mains socket-outlet.
 L'appareil doit être branché sur une prise de courant munie d'une mise à la terre.
 This device complies with Part 15 of the FCC Rules.
 Operation is subject to the following two conditions: (1) this device may not cause harmful interference, and (2) this device must accept any interference received, including interference that may cause undesired operation.



제출일 : 2017년 03월 04일
 모델명 : ADPC2065
 정격 입력 : AC100 ~ 240V 50 ~ 60 Hz 1.5A
 정격 출력 : 20V = 3.25A
 제조업체명 : TPV Electronics(Fujian) Co., Ltd.
 당소명 : Top Valley Electronics(Fujian) Co., Ltd.
 A/S명세서 : 1944 - 7739
 제조연월 : 2015

최저소비효율기준인증제품
EFFICIENCY LEVEL: V
 CAN ICES-3(B)/NMB-3(B)
 SGSEA/131063
 福建捷联电子有限公司
 福建捷联电子有限公司
 中国制造 / 中国製造
 MADE IN CHINA
 Q40G325B-615-01A ZA



13) EUT Photo

