



CE EMC TEST REPORT

REPORT NO.: CE121224D05

MODEL NO.: 215LM****, *2269****

RECEIVED: Dec. 24, 2012

TESTED: Dec. 25 ~ 28, 2012

ISSUED: Jan. 2, 2013

APPLICANT: TOP VICTORY ELECTRONICS (TAIWAN) CO., LTD.

ADDRESS: 10F., No 230, Liancheng Rd., Zhonghe Dist., New Taipei City 23553, Taiwan

ISSUED BY: Bureau Veritas Consumer Products Services (H.K.) Ltd., Taoyuan Branch

LAB LOCATION: No. 47, 14th Ling, Chia Pau Vil., Lin Kou Dist., New Taipei City, Taiwan

This report should not be used by the client to claim product certification, approval, or endorsement by TAF, NVLAP, NIST or any government agencies.



This report is for your exclusive use. Any copying or replication of this report to or for any other person or entity, or use of our name or trademark, is permitted only with our prior written permission. This report sets forth our findings solely with respect to the test samples identified herein. The results set forth in this report are not indicative or representative of the quality or characteristics of the lot from which a test sample was taken or any similar or identical product unless specifically and expressly noted. Our report includes all of the tests requested by you and the results thereof based upon the information that you provided to us. You have 60 days from date of issuance of this report to notify us of any material error or omission caused by our negligence, provided, however, that such notice shall be in writing and shall specifically address the issue you wish to raise. A failure to raise such issue within the prescribed time shall constitute your unqualified acceptance of the completeness of this report, the tests conducted and the correctness of the report contents. Unless specific mention, the uncertainty of measurement has been explicitly taken into account to declare the compliance or non-compliance to the specification

Table of Contents

RELEASE CONTROL RECORD.....	5
1 CERTIFICATION.....	6
2 SUMMARY OF TEST RESULTS.....	7
2.1 MEASUREMENT UNCERTAINTY	9
3 GENERAL INFORMATION	10
3.1 GENERAL DESCRIPTION OF EUT.....	10
3.2 DESCRIPTION OF TEST MODES.....	11
3.3 GENERAL DESCRIPTION OF APPLIED STANDARDS	12
3.4 DESCRIPTION OF SUPPORT UNITS.....	13
3.4.1 FOR EMISSION TEST	13
3.4.2 FOR HARMONICS / FLICKER / IMMUNITY TEST	15
4 EMISSION TEST.....	16
4.1 CONDUCTED EMISSION MEASUREMENT	16
4.1.1 LIMITS OF CONDUCTED EMISSION MEASUREMENT.....	16
4.1.2 TEST INSTRUMENTS	16
4.1.3 TEST PROCEDURE	17
4.1.4 DEVIATION FROM TEST STANDARD	17
4.1.5 TEST SETUP	17
4.1.6 EUT OPERATING CONDITIONS.....	18
4.1.7 TEST RESULTS (1)	19
4.1.8 TEST RESULTS (2)	21
4.2 RADIATED EMISSION MEASUREMENT	23
4.2.1 LIMITS OF RADIATED EMISSION MEASUREMENT.....	23
4.2.2 TEST INSTRUMENTS	24
4.2.3 TEST PROCEDURE	25
4.2.4 DEVIATION FROM TEST STANDARD	25
4.2.5 TEST SETUP	26
4.2.6 EUT OPERATING CONDITIONS.....	26
4.2.7 TEST RESULTS (1)	27
4.2.8 TEST RESULTS (2)	31
4.3 HARMONICS CURRENT MEASUREMENT	35
4.3.1 LIMITS OF HARMONICS CURRENT MEASUREMENT.....	35
4.3.2 TEST INSTRUMENTS	35
4.3.3 TEST PROCEDURE	36
4.3.4 DEVIATION FROM TEST STANDARD	36
4.3.5 TEST SETUP	37
4.3.6 EUT OPERATING CONDITIONS.....	37
4.3.7 TEST RESULTS.....	38
4.4 VOLTAGE FLUCTUATION AND FLICKS MEASUREMENT	39
4.4.1 LIMITS OF VOLTAGE FLUCTUATION AND FLICKS.....	39
4.4.2 TEST INSTRUMENTS	39
4.4.3 TEST PROCEDURE	39
4.4.4 DEVIATION FROM TEST STANDARD	40
4.4.5 TEST SETUP	40



4.4.6	EUT OPERATING CONDITIONS.....	40
4.4.7	TEST RESULTS.....	41
5	IMMUNITY TEST	42
5.1	GENERAL DESCRIPTION.....	42
5.2	GENERAL PERFORMANCE CRITERIA DESCRIPTION	43
5.3	EUT OPERATING CONDITION	44
5.4	ELECTROSTATIC DISCHARGE IMMUNITY TEST (ESD).....	45
5.4.1	TEST SPECIFICATION	45
5.4.2	TEST INSTRUMENTS	45
5.4.3	TEST PROCEDURE	45
5.4.4	DEVIATION FROM TEST STANDARD	46
5.4.5	TEST SETUP	47
5.4.6	TEST RESULTS.....	48
5.5	RADIATED, RADIO-FREQUENCY, ELECTROMAGNETIC FIELD IMMUNITY TEST (RS).....	49
5.5.1	TEST SPECIFICATION	49
5.5.2	TEST INSTRUMENTS	50
5.5.3	TEST PROCEDURE	51
5.5.4	DEVIATION FROM TEST STANDARD	51
5.5.5	TEST SETUP	51
5.5.6	TEST RESULTS.....	52
5.6	ELECTRICAL FAST TRANSIENT/BURST IMMUNITY TEST (EFT)	53
5.6.1	TEST SPECIFICATION	53
5.6.2	TEST INSTRUMENTS	53
5.6.3	TEST PROCEDURE	53
5.6.4	DEVIATION FROM TEST STANDARD	53
5.6.5	TEST SETUP	54
5.6.6	TEST RESULTS.....	55
5.7	SURGE IMMUNITY TEST	56
5.7.1	TEST SPECIFICATION	56
5.7.2	TEST INSTRUMENTS	56
5.7.3	TEST PROCEDURE	57
5.7.4	DEVIATION FROM TEST STANDARD	57
5.7.5	TEST SETUP	57
5.7.6	TEST RESULTS.....	58
5.8	IMMUNITY TO CONDUCTED DISTURBANCES INDUCED BY RF FIELDS (CS).....	59
5.8.1	TEST SPECIFICATION	59
5.8.2	TEST INSTRUMENTS	60
5.8.3	TEST PROCEDURE	61
5.8.4	DEVIATION FROM TEST STANDARD	61
5.8.5	TEST SETUP	62
5.8.6	TEST RESULTS.....	63
5.9	POWER FREQUENCY MAGNETIC FIELD IMMUNITY TEST.....	64
5.9.1	TEST SPECIFICATION	64
5.9.2	TEST INSTRUMENTS	64
5.9.3	TEST PROCEDURE	64
5.9.4	DEVIATION FROM TEST STANDARD	64



A D T

5.9.5	TEST SETUP	65
5.9.6	TEST RESULTS.....	66
5.10	VOLTAGE DIP/SHORT INTERRUPTIONS (DIP) IMMUNITY TEST	67
5.10.1	TEST SPECIFICATION	67
5.10.2	TEST INSTRUMENTS	67
5.10.3	TEST PROCEDURE	67
5.10.4	DEVIATION FROM TEST STANDARD	67
5.10.5	TEST SETUP	68
5.10.6	TEST RESULTS.....	69
6	PHOTOGRAPHS OF THE TEST CONFIGURATION.....	70
7	APPENDIX - INFORMATION ON THE TESTING LABORATORIES.....	83



RELEASE CONTROL RECORD

ISSUE NO.	REASON FOR CHANGE	DATE ISSUED
CE121224D05	Original release	Jan. 2, 2013



A D T

1 CERTIFICATION

PRODUCT: LCD Monitor

MODEL NO.: 215LM****, *2269****

(The "*" can be any alphanumeric character including blank, for marketing differences)

APPLICANT: TOP VICTORY ELECTRONICS (TAIWAN) CO., LTD.

TEST ITEM: ENGINEERING SAMPLE

TESTED: Dec. 25 ~ 28, 2012

STANDARDS: **EN 55022:2010, Class B**

CISPR 22:2008, Class B

AS/NZS CISPR 22:2009, Class B

EN 61000-3-2:2006 +A1:2009 +A2:2009

EN 61000-3-3:2008

EN 55024:2010

IEC 61000-4-2:2008 ED.2.0

IEC 61000-4-3:2010 ED.3.2

IEC 61000-4-4:2012 ED.3.0

IEC 61000-4-5:2005 ED.2.0

IEC 61000-4-6:2008 ED.3.0

IEC 61000-4-8:2009 ED.2.0

IEC 61000-4-11:2004 ED.2.0

The above equipment (Model No.: I2269V_{WM}) has been tested by **Bureau Veritas Consumer Products Services (H.K.) Ltd., Taoyuan Branch**, and found compliance with the requirement of the above standards. The test record, data evaluation & Equipment Under Test (EUT) configurations represented herein are true and accurate accounts of the measurements of the sample's EMC characteristics under the conditions specified in this report.

PREPARED BY : Albee Chu, **DATE:** Jan. 2, 2013
(Albee Chu / Specialist)

APPROVED BY : Kenny Meng, **DATE:** Jan. 2, 2013
(Kenny Meng / Assistant Manager)

2 SUMMARY OF TEST RESULTS

The EUT has been tested according to the following specifications:

EMISSION			
Standard	Test Type	Result	Remarks
EN 55022:2010, Class B	Conducted Test	PASS	Meets Class B Limit Minimum passing margin is -8.84 dB at 0.55234 MHz
CISPR 22:2008, Class B	Conducted Test (Telecom port)	N/A	EUT has no telecom port.
AS/NZS CISPR 22: 2009, Class B	Radiated Test (30MHz ~ 6GHz)	PASS	Meets Class B Limit Minimum passing margin is -4.15 dB at 741.76 MHz
EN 61000-3-2:2006 +A1:2009+A2:2009	Harmonic current emissions	PASS	The power consumption of EUT is less than 75W and no limits apply
EN 61000-3-3:2008	Voltage fluctuations & flicker	PASS	Meets the requirements.



A D T

IMMUNITY (EN 55024:2010)			
Standard	Test Type	Result	Remarks
IEC 61000-4-2:2008 ED.2.0	Electrostatic discharge immunity test	PASS	Meets the requirements of Performance Criterion B
IEC 61000-4-3:2010 ED.3.2	Radiated, radio-frequency, electromagnetic field immunity test	PASS	Meets the requirements of Performance Criterion A
IEC 61000-4-4:2012 ED.3.0	Electrical fast transient / burst immunity test.	PASS	Meets the requirements of Performance Criterion A
IEC 61000-4-5:2005 ED.2.0	Surge immunity test	PASS	Meets the requirements of Performance Criterion A
IEC 61000-4-6:2008 ED.3.0	Immunity to conducted disturbances, induced by radio-frequency fields	PASS	Meets the requirements of Performance Criterion A
IEC 61000-4-8:2009 ED.2.0	Power frequency magnetic field immunity test.	PASS	Meets the requirements of Performance Criterion A
IEC 61000-4-11:2004 ED.2.0	Voltage dips and short interruptions immunity tests	PASS	Meets the requirements of Voltage Dips: i) >95% reduction - Performance Criterion A ii) 30% reduction – Performance Criterion A Voltage Interruptions: i) >95% reduction – Performance Criterion B

2.1 MEASUREMENT UNCERTAINTY

Where relevant, the following measurement uncertainty levels have been estimated for tests performed on the EUT as specified in CISPR 16-4-2:

"This uncertainty represents an expanded uncertainty expressed at approximately the 95% confidence level using a coverage factor of $k=2$."

MEASUREMENT	FREQUENCY	UNCERTAINTY
Conducted emissions	150kHz ~ 30MHz	+/- 3.43 dB
Radiated emissions	30MHz ~ 1GHz	+/- 3.64 dB
	Above 1GHz	+/- 3.36 dB

The listed uncertainties are the worst case uncertainty for the entire range of measurement. Please note that the uncertainty values are provided for informational purposes only and are not used in determining the PASS/FAIL results.

3 GENERAL INFORMATION

3.1 GENERAL DESCRIPTION OF EUT

PRODUCT	LCD Monitor
MODEL NO.	215LM*****, *2269****
POWER SUPPLY	Internal Switching Power Supply Rating: 100-240V, 50/60Hz Power Cord: Non-shielded AC 3-pin (1.5m).
DATA CABLE SUPPLIED	Shielded D-Sub cable (1.5m) with two ferrite cores Shielded HDMI (MHL) cable (1.5m) Shielded HDMI cable (1.5m) Shielded Display cable (1.8m) Shielded Audio cable (1.5m)

NOTE:

1. The EUT is a LCD Monitor and the resolution is up to 1920 x 1080 (60Hz).
2. The EUT has several models, which are identical to each other except for their marketing differences only, as the following:

Model No.	Interfaces	Difference
215LM*****	<ul style="list-style-type: none"> ◆ D-Sub in ◆ Display in ◆ HDMI in 	For marketing differences
*2269****	<ul style="list-style-type: none"> ◆ HDMI in (MHL) ◆ Audio in ◆ Earphone 	
(The "*" can be any alphanumeric character including blank for marketing differences.)		

During the test, **model no.: I2269V_{WM}** was selected as the representative one and therefore only its test data was recorded in this report.

3. For a more detailed features description, please refer to the manufacturer's specifications or the User's Manual.

3.2 DESCRIPTION OF TEST MODES

1. The EUT is designed with AC power supply of 100-240Vac, 50/60Hz. For radiated emission evaluation, 230Vac/ 50Hz (for EN 55022 & AS/NZS CISPR 22), 120Vac/ 60Hz (for FCC Part 15), 110Vac/ 60Hz (for BSMI CNS 13438), 100V/50Hz (for VCCI) had been covered during the pre-test. The worst radiated emission data was founded at **110Vac/ 60Hz** and recorded in the applied test report.
2. The EUT was pre-tested resolution 1920 x 1080 (60Hz) of the D-Sub, Display & HDMI interfaces. The worst emission level was found under the **D-Sub** interface. Therefore the EUT was pre-testing under the following resolution & refresh rate modes:

Interface	Resolution
D-Sub	1920 x 1080 (60Hz)
	1280 x 1024 (75Hz)
	640 x 480 (60Hz)
HDMI to DVD	1080p
HDMI (MHL) to phone	1080p

The worst radiated emission level was found when EUT tested under **D-Sub 1920 x 1080 (60Hz)**.

3. According to pretested result and client's requirement, the EUT was tested under the following modes:

Test Item	Test Mode	Interface	Resolution
Conducted & Radiated tests	Mode 1	D-Sub	1920 x 1080 (60Hz)
	Mode 2	HDMI to DVD	1080p
Harmonic Flicker & Immunity tests	Mode 1	D-Sub	1920 x 1080 (60Hz)

All above test modes were recorded in this report.

3.3 GENERAL DESCRIPTION OF APPLIED STANDARDS

The EUT is a kind of ITE equipment and, according to the specifications of the manufacturers, must comply with the requirements of the following standards:

EN 55022:2010, Class B

CISPR 22:2008, Class B

AS/NZS CISPR 22:2009, Class B

EN 61000-3-2:2006 +A1:2009 +A2:2009

EN 61000-3-3:2008

EN 55024:2010

IEC 61000-4-2:2008 ED.2.0

IEC 61000-4-3:2010 ED.3.2

IEC 61000-4-4:2012 ED.3.0

IEC 61000-4-5:2005 ED.2.0

IEC 61000-4-6:2008 ED.3.0

IEC 61000-4-8:2009 ED.2.0

IEC 61000-4-11:2004 ED.2.0

Notes: The above IEC basic standards are applied with latest version if customer has no special requirement

3.4 DESCRIPTION OF SUPPORT UNITS

The EUT has been tested as an independent unit together with other necessary accessories or support units. The following support units or accessories were used to form a representative test configuration during the tests.

3.4.1 FOR EMISSION TEST

NO.	PRODUCT	BRAND	MODEL NO.	SERIAL NO.	FCC ID
1	PERSONAL COMPUTER	HP	6000ProMT	SGH110SGNJ	FCC DoC Approved
2	PRINTER	LEXMARK	Z33	03331652572	FCC DoC Approved
3	MODEM	ACEEX	1414	980020506	IFAXDM1414
4	DVD PLAYER	SONY	BDP-S470	3205076	Verification
5	Mobile Phone	HTC	PJ46100	HT261W101910	NM8PJ46100
6	EARPHONE	PHILIPS	SBC HL145	N/A	N/A
7	USB KEYBOARD	BTC	5200U	G09302046623	E5XKB5122U
8	USB MOUSE	MICROSOFT	X800898	9241991-30608	FCC DoC Approved
9	VGA CARD	ASUS	ENGT440/DI/1G D3	BACVCM03880 2	FCC DoC Approved

NO.	SIGNAL CABLE DESCRIPTION OF THE ABOVE SUPPORT UNITS
1	1.5 m shielded D-Sub cable with two cores. (provided by client) 1.8 m shielded Display cable. (provided by client) 1.5 m shielded Audio cable; (provided by client)
2	2.0 m foil shielded wire, terminated with USB connector via metallic frame, w/o core.
3	1.2 m braid shielded wire, terminated with DB25 and DB9 connector via metallic frame, w/o core.
4	1.5 m HDMI cable (provided by client)
5	1.5 m HDMI (MHL) cable (provided by client)
6	1.2 m wrapped shielded wire, terminated with 3.5mm phone plug via drain wire, w/o core.
7	1.5 m braid shielded wire, terminated with USB connector via drain wire, w/o core.
8	1.8 m foil shielded wire, terminated with USB connector via drain wire, with 1 core.
9	N/A

NOTE: (1) All power cords of the above support units are non-shielded (1.8 m).
(2) The support unit 9 was installed in support unit 1.



TEST CONFIGURATION

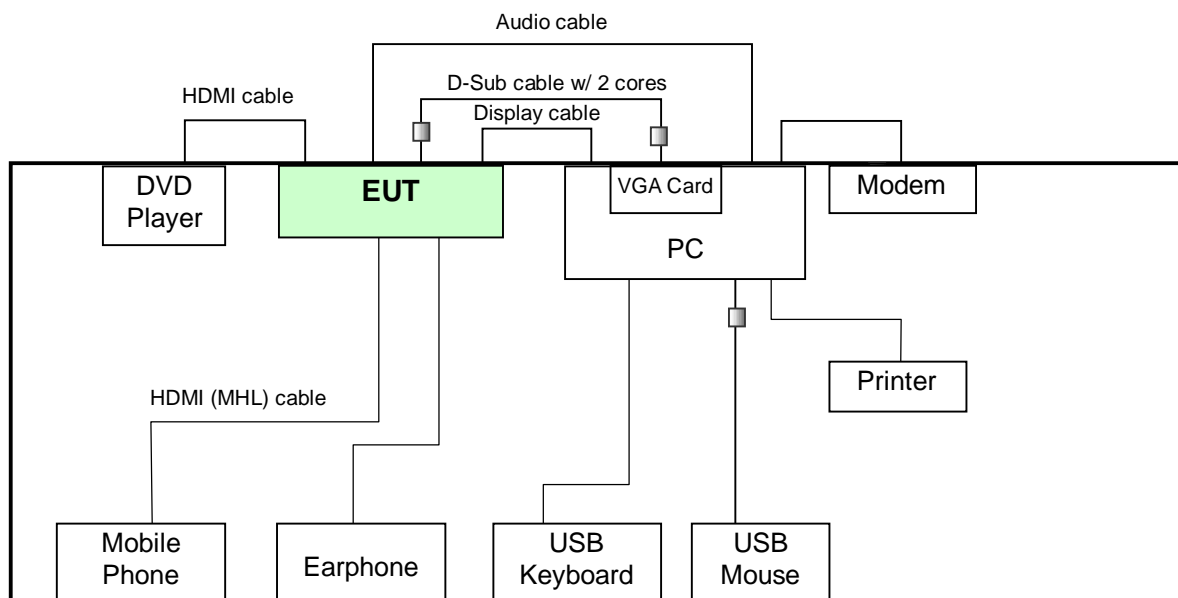



3.4.2 FOR HARMONICS / FLICKER / IMMUNITY TEST

NO.	PRODUCT	BRAND	MODEL NO.	SERIAL NO.	FCC ID
1	PERSONAL COMPUTER	DELL	VOSTRO 470	1XHKYBX	FCC DoC Approved
2	USB KEYBOARD	DELL	SK-8115	CN-0J4635-716 16-63I-076X	FCC DoC Approved
3	USB MOUSE	LOGITECH	M-BB48	LZE93051142	FCC DoC Approved

NO.	SIGNAL CABLE DESCRIPTION OF THE ABOVE SUPPORT UNITS
1	1.5 m shielded D-Sub cable with two cores. (provided by client) 1.5 m shielded Audio cable; (provided by client)
2	2.0 m foil shielded wire, terminated with USB connector via drain wire, one core
3	1.8 m foil shielded wire, terminated with USB connector via drain wire, w/o core.

NOTE: All power cords of the above support units are non shielded (1.8m).

TEST CONFIGURATION

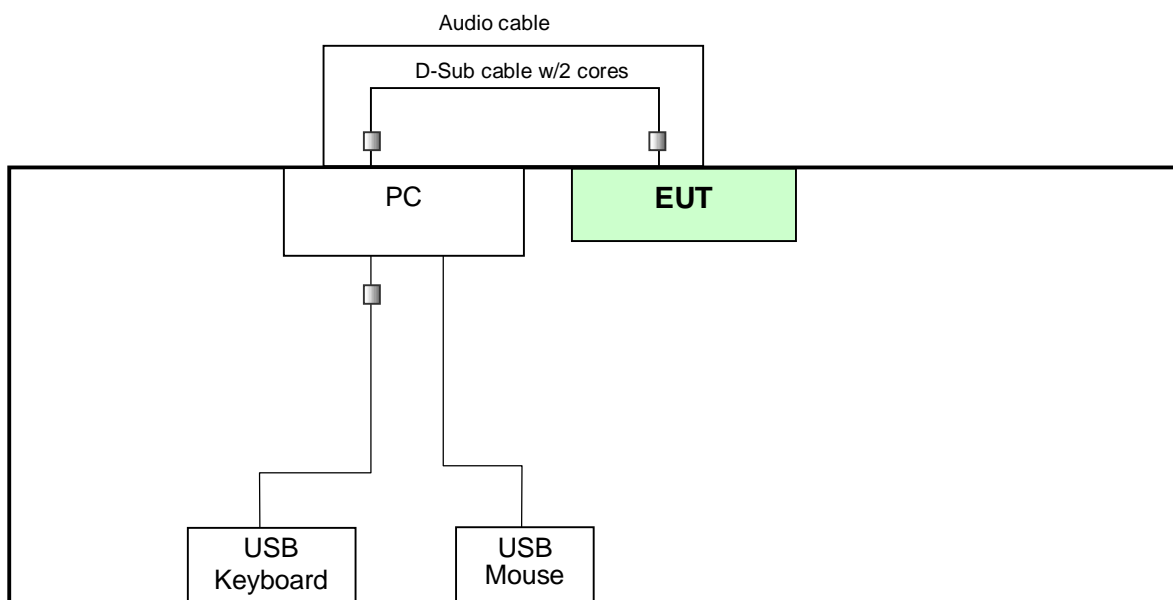

4 EMISSION TEST

4.1 CONDUCTED EMISSION MEASUREMENT

4.1.1 LIMITS OF CONDUCTED EMISSION MEASUREMENT

TEST STANDARD: EN 55022

FREQUENCY (MHz)	Class A (dBuV)		Class B (dBuV)	
	Quasi-peak	Average	Quasi-peak	Average
0.15 - 0.5	79	66	66 - 56	56 - 46
0.50 - 5.0	73	60	56	46
5.0 - 30.0	73	60	60	50

- NOTE:**
- (1) The lower limit shall apply at the transition frequencies.
 - (2) The limit decreases in line with the logarithm of the frequency in the range of 0.15 to 0.50 MHz.

4.1.2 TEST INSTRUMENTS

DESCRIPTION & MANUFACTURER	MODEL NO.	SERIAL NO.	CALIBRATED DATE	CALIBRATED UNTIL
ROHDE & SCHWARZ Test Receiver	ESCS 30	100290	Dec. 24, 2012	Dec. 23, 2013
ROHDE & SCHWARZ Artificial Mains Network (for EUT)	ESH3-Z5	839135/006	Sep. 24, 2012	Sep. 23, 2013
LISN With Adapter (for EUT)	AD10	C00Ada-001	Sep. 24, 2012	Sep. 23, 2013
EMCO-L.I.S.N. (for peripheral)	3825/2	9204-1964	May 28, 2012	May 27, 2013
Software	ADT_Cond_V7.3.7	NA	NA	NA
Software	ADT_ISN_V7.3.7	NA	NA	NA
RF cable (JYEBAO)	5D-FB	Cable-C02.01	Jan. 08, 2012	Jan. 07, 2013
LYNICS Terminator (For EMCO LISN)	0900510	E1-01-284	Sep. 24, 2012	Sep. 23, 2013
LYNICS Terminator (For EMCO LISN)	0900510	E1-01-285	Sep. 24, 2012	Sep. 23, 2013

- NOTE:**
1. The calibration interval of the above test instruments is 12 months and the calibrations are traceable to NML/ROC and NIST/USA.
 2. The test was performed in Shielded Room No. 2.
 3. The VCCI Site Registration No. C-240.
 4. Tested Date: Dec. 27, 2012.

4.1.3 TEST PROCEDURE

- a. The EUT was placed 0.4 meters from the conducting wall of the shielded room with EUT being connected to the power mains through a line impedance stabilization network (LISN). Other support units were connected to the power mains through another LISN. The two LISNs provide 50 Ohm/ 50uH of coupling impedance for the measuring instrument.
- b. Both lines of the power mains connected to the EUT were checked for maximum conducted interference.
- c. The frequency range from 150 kHz to 30 MHz was searched. Emission levels under (Limit - 20dB) were not recorded.

4.1.4 DEVIATION FROM TEST STANDARD

No deviation

4.1.5 TEST SETUP

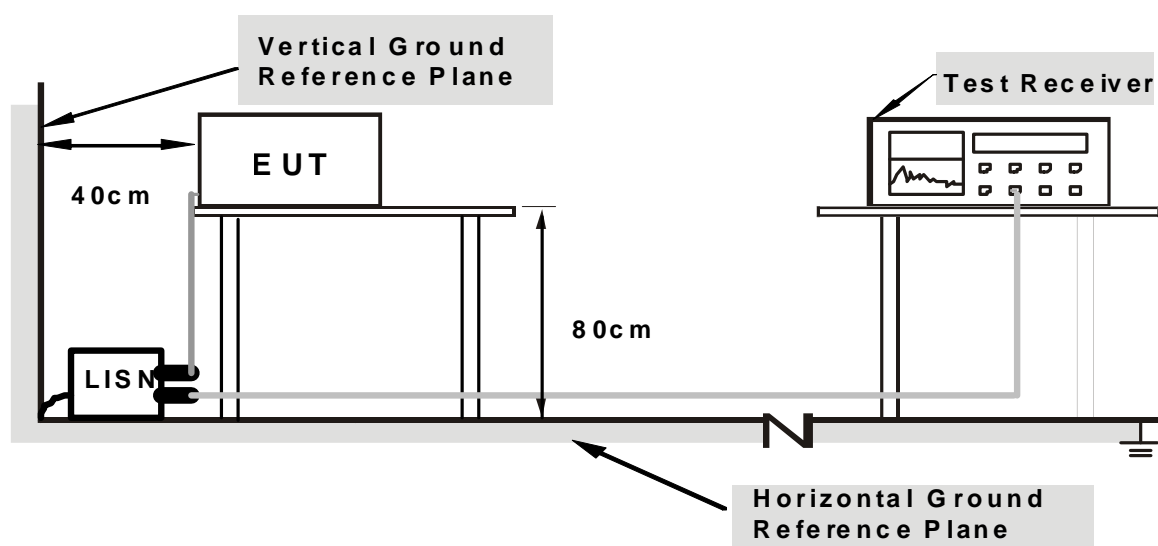

Note: Support units were connected to second LISN.

For the actual test configuration, please refer to the related item – Photographs of the Test Configuration.

4.1.6 EUT OPERATING CONDITIONS

- a. Turned on the power of all equipment.
- b. PC ran a test program (WinFCC) to enable all functions.
- c. PC read and wrote messages from HDD.
- d. PC sent “H” messages to EUT, and then EUT displayed them on its screen. **<For Mode 1>**
- e. DVD player sent color bars to EUT, and then EUT displayed them on its screen. **<For Mode 2>**
- f. PC sent messages to printer and printer printed them out.
- g. PC sent messages to modem.
- h. PC sent “1kHz audio signal” to earphone via EUT.
- i. Steps c-i were repeated.

4.1.7 TEST RESULTS (1)

TEST MODE	Mode 1	6DB BANDWIDTH	9 kHz
INPUT POWER	230Vac, 50 Hz	PHASE	Line (L)
ENVIRONMENTAL CONDITIONS	22deg. C, 82% RH	TESTED BY: Paul Chen	

No	Freq. [MHz]	Corr. Factor (dB)	Reading Value [dB (uV)]		Emission Level [dB (uV)]		Limit [dB (uV)]		Margin (dB)	
			Q.P.	AV.	Q.P.	AV.	Q.P.	AV.	Q.P.	AV.
			1	0.15391	0.30	52.09	38.17	52.39	38.47	65.79
2	0.18125	0.32	50.50	41.68	50.82	42.00	64.43	54.43	-13.61	-12.43
3	0.56016	0.55	40.86	36.31	41.41	36.86	56.00	46.00	-14.59	-9.14
4	0.61484	0.57	41.25	36.32	41.82	36.89	56.00	46.00	-14.18	-9.11
5	2.78906	0.93	38.66	32.42	39.59	33.35	56.00	46.00	-16.41	-12.65
6	6.10156	1.24	40.21	35.50	41.45	36.74	60.00	50.00	-18.55	-13.26

REMARKS:

1. Q.P. and AV. are abbreviations of quasi-peak and average individually.
2. The emission levels of other frequencies were very low against the limit.
3. Margin value = Emission level - Limit value
4. Correction factor = Insertion loss + Cable loss
5. Emission Level = Correction Factor + Reading Value.

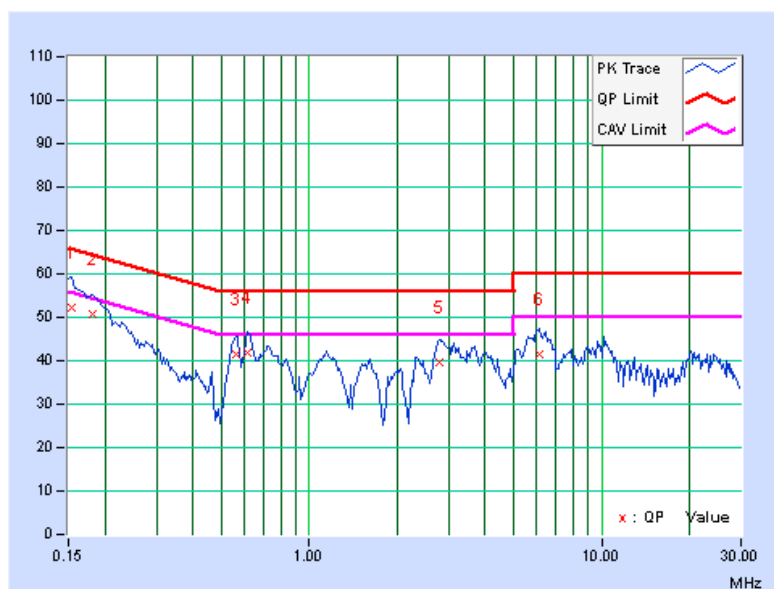



A D T

TEST MODE	Mode 1	6dB BANDWIDTH	9 kHz
INPUT POWER	230Vac, 50 Hz	PHASE	Neutral (N)
ENVIRONMENTAL CONDITIONS	22deg. C, 82% RH	TESTED BY: Paul Chen	

No	Freq. [MHz]	Corr. Factor (dB)	Reading Value		Emission Level		Limit		Margin	
			[dB (uV)]		[dB (uV)]		[dB (uV)]		(dB)	
			Q.P.	AV.	Q.P.	AV.	Q.P.	AV.	Q.P.	AV.
1	0.15000	0.20	52.76	40.24	52.96	40.44	66.00	56.00	-13.04	-15.56
2	0.18380	0.20	50.84	43.69	51.04	43.89	64.31	54.31	-13.27	-10.42
3	0.55234	0.31	40.74	36.06	41.05	36.37	56.00	46.00	-14.95	-9.63
4	0.62266	0.32	40.28	35.11	40.60	35.43	56.00	46.00	-15.40	-10.57
5	2.87891	0.67	38.67	32.43	39.34	33.10	56.00	46.00	-16.66	-12.90
6	3.62109	0.78	37.84	33.12	38.62	33.90	56.00	46.00	-17.38	-12.10
7	6.10938	1.04	41.54	36.80	42.58	37.84	60.00	50.00	-17.42	-12.16

REMARKS:

1. Q.P. and AV. are abbreviations of quasi-peak and average individually.
2. The emission levels of other frequencies were very low against the limit.
3. Margin value = Emission level - Limit value
4. Correction factor = Insertion loss + Cable loss
5. Emission Level = Correction Factor + Reading Value.

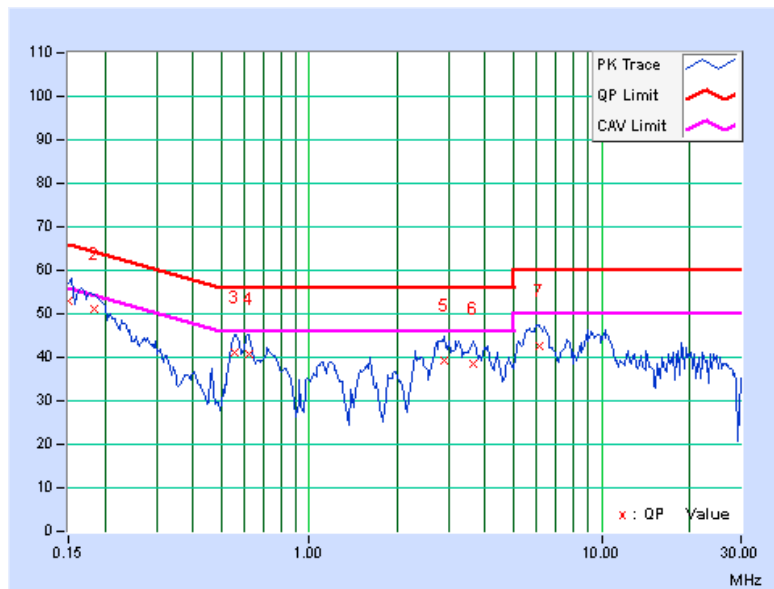



A D T

4.1.8 TEST RESULTS (2)

TEST MODE	Mode 2	6DB BANDWIDTH	9 kHz
INPUT POWER	230Vac, 50 Hz	PHASE	Line (L)
ENVIRONMENTAL CONDITIONS	22deg. C, 82% RH	TESTED BY: Paul Chen	

No	Freq. [MHz]	Corr. Factor (dB)	Reading Value [dB (uV)]		Emission Level [dB (uV)]		Limit [dB (uV)]		Margin (dB)	
			Q.P.	AV.	Q.P.	AV.	Q.P.	AV.	Q.P.	AV.
			1	0.15000	0.29	54.17	44.64	54.46	44.93	66.00
2	0.18116	0.32	49.00	39.71	49.32	40.03	64.43	54.43	-15.11	-14.40
3	0.55234	0.55	42.08	36.61	42.63	37.16	56.00	46.00	-13.37	-8.84
4	0.61875	0.57	41.86	36.09	42.43	36.66	56.00	46.00	-13.57	-9.34
5	0.72813	0.62	39.44	34.47	40.06	35.09	56.00	46.00	-15.94	-10.91
6	2.77344	0.93	40.30	34.63	41.23	35.56	56.00	46.00	-14.77	-10.44
7	4.99872	1.14	36.01	30.79	37.15	31.93	56.00	46.00	-18.85	-14.07
8	5.57422	1.19	41.23	36.42	42.42	37.61	60.00	50.00	-17.58	-12.39

REMARKS:

1. Q.P. and AV. are abbreviations of quasi-peak and average individually.
2. The emission levels of other frequencies were very low against the limit.
3. Margin value = Emission level - Limit value
4. Correction factor = Insertion loss + Cable loss
5. Emission Level = Correction Factor + Reading Value.

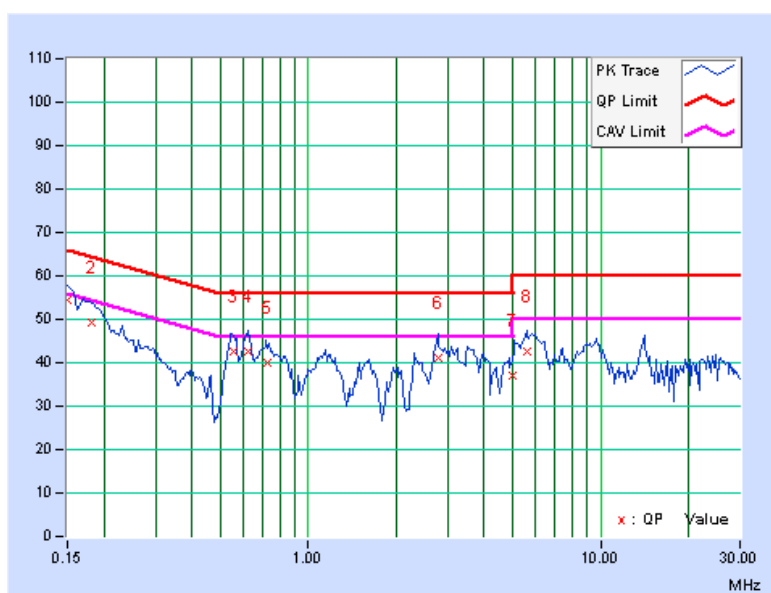



A D T

TEST MODE	Mode 2	6dB BANDWIDTH	9 kHz
INPUT POWER	230Vac, 50 Hz	PHASE	Neutral (N)
ENVIRONMENTAL CONDITIONS	22deg. C, 82% RH	TESTED BY: Paul Chen	

No	Freq. [MHz]	Corr. Factor (dB)	Reading Value		Emission Level		Limit		Margin	
			[dB (uV)]		[dB (uV)]		[dB (uV)]		(dB)	
			Q.P.	AV.	Q.P.	AV.	Q.P.	AV.	Q.P.	AV.
1	0.15000	0.20	53.83	44.66	54.03	44.86	66.00	56.00	-11.97	-11.14
2	0.18125	0.20	49.52	40.73	49.72	40.93	64.43	54.43	-14.71	-13.50
3	0.55234	0.31	42.06	36.63	42.37	36.94	56.00	46.00	-13.63	-9.06
4	0.61484	0.32	41.30	35.73	41.62	36.05	56.00	46.00	-14.38	-9.95
5	2.79688	0.66	39.80	33.73	40.46	34.39	56.00	46.00	-15.54	-11.61
6	5.99609	1.03	41.99	37.22	43.02	38.25	60.00	50.00	-16.98	-11.75
7	9.70703	1.40	42.09	37.16	43.49	38.56	60.00	50.00	-16.51	-11.44

REMARKS:

1. Q.P. and AV. are abbreviations of quasi-peak and average individually.
2. The emission levels of other frequencies were very low against the limit.
3. Margin value = Emission level - Limit value
4. Correction factor = Insertion loss + Cable loss
5. Emission Level = Correction Factor + Reading Value.

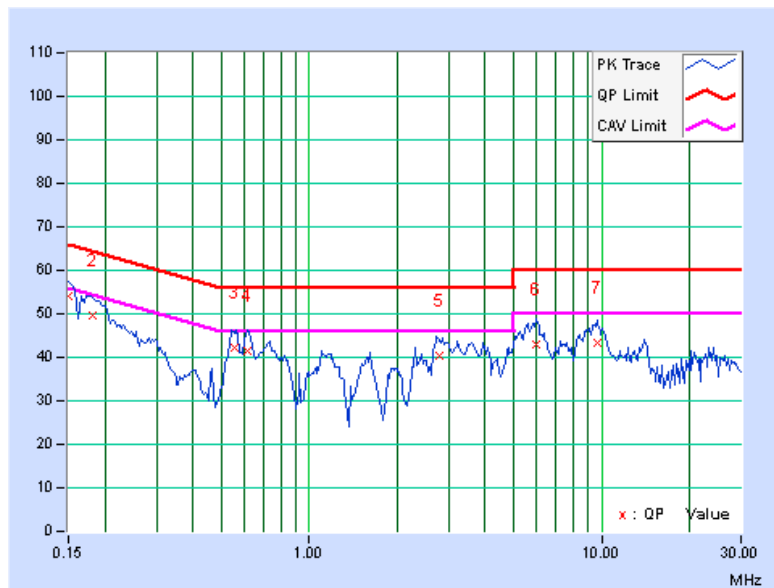

4.2 RADIATED EMISSION MEASUREMENT

4.2.1 LIMITS OF RADIATED EMISSION MEASUREMENT

TEST STANDARD: EN 55022

FOR FREQUENCY BELOW 1000 MHz

FREQUENCY (MHz)	Class A (at 10m)	Class B (at 10m)
	dBuV/m	dBuV/m
30 – 230	40	30
230 – 1000	47	37

FOR FREQUENCY ABOVE 1000 MHz

FREQUENCY (GHz)	Class A (dBuV/m) (at 3m)		Class B (dBuV/m) (at 3m)	
	PEAK	AVERAGE	PEAK	AVERAGE
1 to 3	76	56	70	50
3 to 6	80	60	74	54

- NOTE:** (1) The lower limit shall apply at the transition frequencies.
 (2) Emission level (dBuV/m) = 20 log Emission level (uV/m).
 (3) All emanation from a class A/B digital device or system, including any network of conductors and apparatus connected thereto, shall not exceed the level of field strengths specified above.

FREQUENCY RANGE OF RADIATED MEASUREMENT (For unintentional radiators)

Highest frequency generated or used in the device or on which the device operates or tunes (MHz)	Upper frequency of measurement Range (MHz)
Below 108	1000
108 – 500	2000
500 – 1000	5000
Above 1000	Up to 5 times of the highest frequency or 6 GHz, whichever is less

4.2.2 TEST INSTRUMENTS

Frequency Range 30MHz~1GHz

DESCRIPTION & MANUFACTURER	MODEL NO.	SERIAL NO.	CALIBRATED DATE	CALIBRATED UNTIL
R&S Receiver	ESCI	100612	Sep. 20, 2012	Sep. 19, 2013
CHASE BILOG Antenna	CBL6112B	2640	Apr. 06, 2012	Apr. 05, 2013
ADT Turn Table	TT100	0204	NA	NA
ADT Tower	AT100	0204	NA	NA
Software	ADT_Radiated_V7.6.15.9.2	NA	NA	NA
ADT RF Switches BOX	EM-H-01-1	1005	Jul. 05, 2012	Jul. 04, 2013
WOKEN RF cable	8D	CABLE-ST1-01	Jul. 05, 2012	Jul. 04, 2013

- NOTE:** 1. The calibration interval of the above test instruments is 12 months. And the calibrations are traceable to NML/ROC and NIST/USA.
 2. The test was performed in Open Site No. 1.
 3. The VCCI Site Registration No. R-236.
 4. The FCC Site Registration No. 90423.
 5. Tested Date: Dec. 25, 2012.

Frequency Range above 1GHz

DESCRIPTION & MANUFACTURER	MODEL NO.	SERIAL NO.	CALIBRATED DATE	CALIBRATED UNTIL
Agilent Spectrum	E4446A	MY51100009	Jun. 26, 2012	Jun. 25, 2013
EMCI Preamplifier	EMC0126545	980076	Mar. 01, 2012	Feb. 28, 2013
MITEQ Preamplifier	AMF-6F-260400-33-8P	892164	Mar. 02, 2012	Mar. 01, 2013
Schwarzbeck Horn Antenna	BBHA-9170	BBHA9170190	Oct. 04, 2012	Oct. 03, 2013
EMCO Horn Antenna	3115	6714	Oct. 25, 2012	Oct. 24, 2013
Max Full. Turn Table	MF7802	MF780208216	NA	NA
Software	ADT_Radiated_V8.7.05	NA	NA	NA
SUHNER RF cable	SF106-18	Cable-CH10	Aug. 19, 2012	Aug. 18, 2013

- NOTE:** 1. The calibration interval of the above test instruments is 12 months. And the calibrations are traceable to NML/ROC and NIST/USA.
 2. The 3dB beamwidth of the horn antenna is minimum 30 degree (or $w = 1.6m$ at 3m distance) for 1~6 GHz.
 3. The test was performed in Chamber No. 10.
 4. The Industry Canada Reference No. IC 7450E-11.
 5. The VCCI Site Registration No. G427
 6. The FCC Site Registration No. 367016
 7. Tested Date: Dec. 27, 2012

4.2.3 TEST PROCEDURE

<Frequency Range 30MHz ~ 1GHz>

- a. The EUT was placed on the top of a rotating table 0.8 meters above the ground at a 10 meter open area test site. The table was rotated 360 degrees to determine the position of the highest radiation.
- b. The EUT was set 10 meters away from the interference-receiving antenna, which was mounted on the top of a variable-height antenna tower.
- c. The height of antenna is varied from one meter to four meters above the ground to determine the maximum value of the field strength. Both horizontal and vertical polarizations of the antenna are set to make the measurement.
- d. For each suspected emission, the EUT was arranged to its worst case and then the antenna was tuned to heights from 1 meter to 4 meters and the turn table was turned from 0 degrees to 360 degrees to find the maximum reading.
- e. The test-receiver system was set to quasi-peak detect function and specified bandwidth with maximum hold mode when the test frequency is below 1 GHz.

NOTE: The resolution bandwidth of test receiver/spectrum analyzer is 120kHz for Quasi-peak detection (QP) at frequency below 1GHz.

<Frequency Range above 1GHz>

- a. The EUT was placed on the top of a rotating table 0.8 meters above the ground at a 3 meter Semi-anechoic chamber room. The table was rotated 360 degrees to determine the position of the highest radiation.
- b. The EUT was set 3 meters away from the interference-receiving antenna, which was mounted on the top of a variable-height antenna tower.
- c. The height of antenna can be varied from one meter-to four meters, the height of adjustment depends on the EUT height and the antenna 3dB beamwidth both, to detect the maximum value of the field strength. Both horizontal and vertical polarizations of the antenna are set to make the measurement.
- d. For each suspected emission, the EUT was arranged to its worst case and then the antenna was tuned to heights and the rotatable table was turned from 0 degrees to 360 degrees to find the maximum reading.
- e. The test-receiver system was set to peak and average detect function and specified bandwidth with maximum hold mode when the test frequency is above 1 GHz.

NOTE:

1. The resolution bandwidth is 1MHz and video bandwidth of test receiver/spectrum analyzer is 3MHz for Peak detection at frequency above 1GHz. The resolution bandwidth of test receiver/spectrum analyzer is 1 MHz for Average detection (AV) at frequency above 1GHz.
2. For measurement of frequency above 1000 MHz, the EUT was set 3 meters away from the receiver antenna.

4.2.4 DEVIATION FROM TEST STANDARD

No deviation

4.2.5 TEST SETUP

<Frequency Range 30MHz ~ 1GHz >

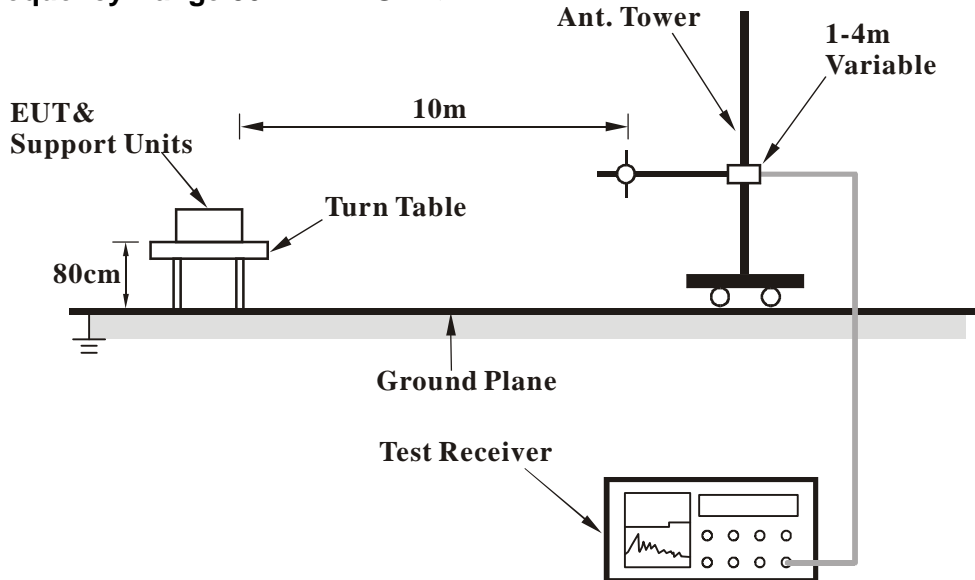

<Frequency Range above 1GHz>

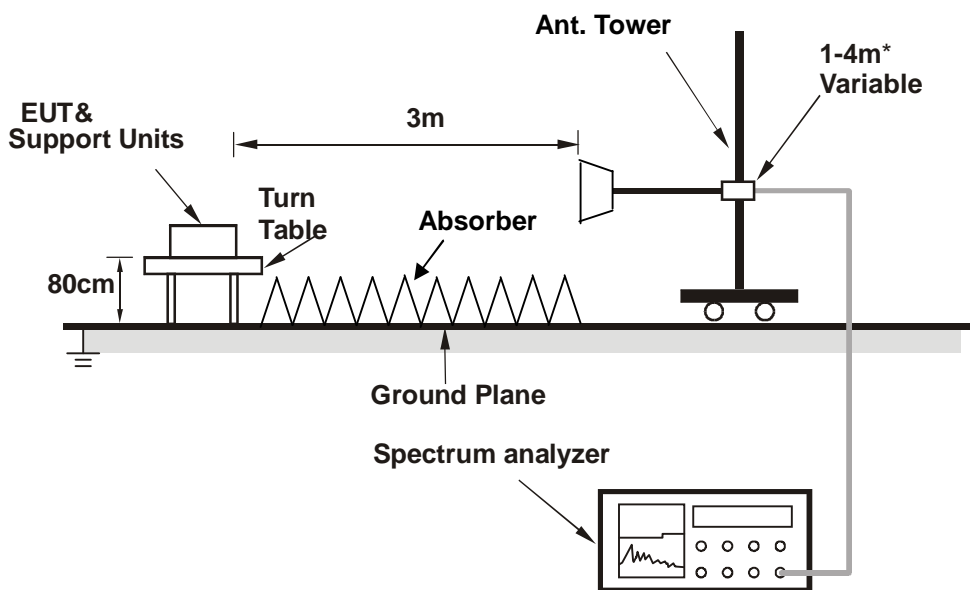

* : depends on the EUT height and the antenna 3dB beamwidth both.

For the actual test configuration, please refer to the related item – Photographs of the Test Configuration.

4.2.6 EUT OPERATING CONDITIONS

Same as item 4.1.6

4.2.7 TEST RESULTS (1)

TEST MODE	Mode 1		
FREQUENCY RANGE	30-1000 MHz	DETECTOR FUNCTION & BANDWIDTH	Quasi-Peak, 120 kHz
ENVIRONMENTAL CONDITIONS	18deg. C, 75% RH,	TESTED BY: Hermes Lin	

ANTENNA POLARITY & TEST DISTANCE: HORIZONTAL AT 10 M

No.	Freq. (MHz)	Emission Level (dBuV/m)	Limit (dBuV/m)	Margin (dB)	Antenna Height (m)	Table Angle (Degree)	Raw Value (dBuV)	Correction Factor (dB/m)
1	71.47	20.11 QP	30.00	-9.89	4.00 H	124	7.55	12.56
2	127.04	19.43 QP	30.00	-10.57	4.00 H	123	6.37	13.06
3	150.33	22.96 QP	30.00	-7.04	4.00 H	281	7.58	15.38
4	156.46	23.99 QP	30.00	-6.01	4.00 H	257	8.85	15.14
5	174.89	20.11 QP	30.00	-9.89	4.00 H	173	6.03	14.08
6	187.14	23.52 QP	30.00	-6.48	4.00 H	167	10.44	13.08
7	198.00	23.13 QP	30.00	-6.87	4.00 H	207	10.97	12.16
8	205.70	18.98 QP	30.00	-11.02	4.00 H	55	6.72	12.26
9	218.19	20.54 QP	30.00	-9.46	4.00 H	117	7.71	12.83
10	229.46	21.82 QP	30.00	-8.18	4.00 H	251	8.47	13.35
11	248.27	31.60 QP	37.00	-5.40	4.00 H	97	17.38	14.22
12	297.18	18.74 QP	37.00	-18.26	4.00 H	217	2.08	16.66
13	445.99	21.19 QP	37.00	-15.81	1.00 H	8	0.35	20.84
14	742.50	27.63 QP	37.00	-9.37	1.00 H	214	0.57	27.06
15	891.03	29.52 QP	37.00	-7.48	1.50 H	196	0.21	29.31

REMARKS:

1. Emission level(dBuV/m)=Raw Value(dBuV) + Correction Factor(dB/m)
2. Correction Factor(dB/m) = Antenna Factor (dB/m) + Cable Factor (dB)
3. The other emission levels were very low against the limit.
4. Margin value = Emission level – Limit value.

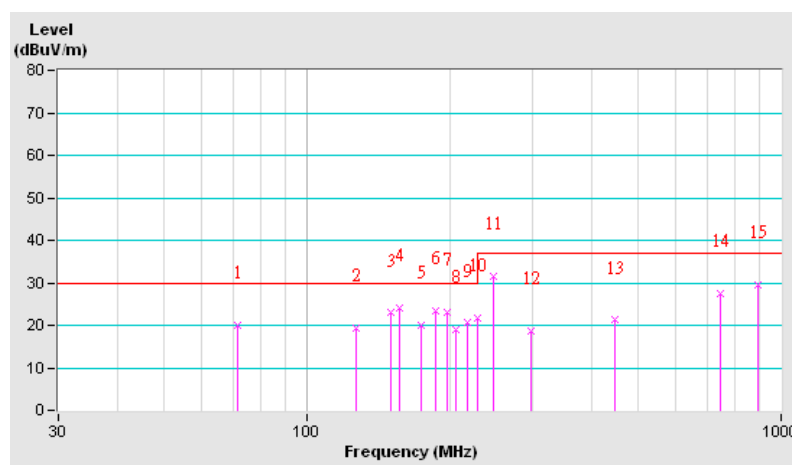



A D T

TEST MODE	Mode 1		
FREQUENCY RANGE	30-1000 MHz	DETECTOR FUNCTION & BANDWIDTH	Quasi-Peak, 120 kHz
ENVIRONMENTAL CONDITIONS	18deg. C, 75% RH,	TESTED BY: Hermes Lin	

ANTENNA POLARITY & TEST DISTANCE: VERTICAL AT 10 M

No.	Freq. (MHz)	Emission Level (dBuV/m)	Limit (dBuV/m)	Margin (dB)	Antenna Height (m)	Table Angle (Degree)	Raw Value (dBuV)	Correction Factor (dB/m)
1	62.77	24.38 QP	30.00	-5.62	1.00 V	19	10.70	13.68
2	115.25	23.80 QP	30.00	-6.20	1.00 V	26	11.92	11.88
3	128.01	25.32 QP	30.00	-4.68	1.00 V	26	12.18	13.14
4	148.50	20.20 QP	30.00	-9.80	1.00 V	42	5.00	15.20
5	184.74	22.05 QP	30.00	-7.95	1.00 V	313	8.77	13.28
6	198.01	25.33 QP	30.00	-4.67	1.00 V	0	13.17	12.16
7	203.14	20.72 QP	30.00	-9.28	1.00 V	196	8.58	12.14
8	218.18	22.27 QP	30.00	-7.73	1.00 V	51	9.44	12.83
9	229.52	23.20 QP	30.00	-6.80	1.00 V	159	9.85	13.35
10	248.27	26.27 QP	37.00	-10.73	1.50 V	304	12.05	14.22
11	375.75	26.34 QP	37.00	-10.66	1.02 V	18	7.44	18.90
12	446.00	25.83 QP	37.00	-11.17	1.00 V	68	4.99	20.84
13	742.50	27.35 QP	37.00	-9.65	3.54 V	210	0.29	27.06

REMARKS:

1. Emission level(dBuV/m)=Raw Value(dBuV) + Correction Factor(dB/m)
2. Correction Factor(dB/m) = Antenna Factor (dB/m) + Cable Factor (dB)
3. The other emission levels were very low against the limit.
4. Margin value = Emission level – Limit value.

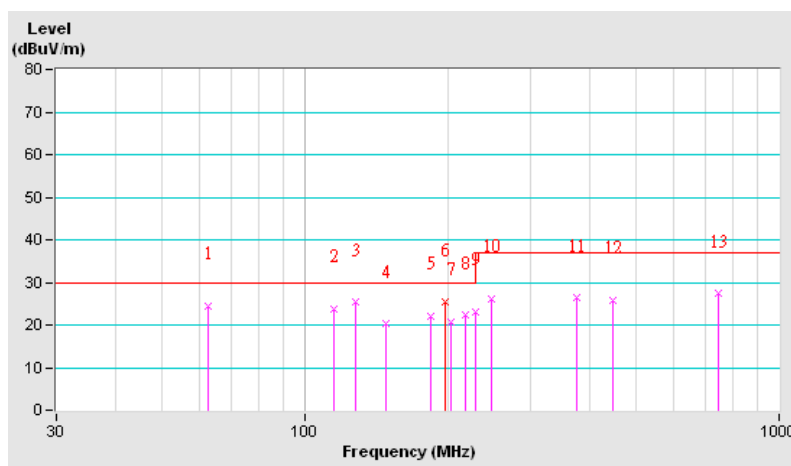

TEST MODE	Mode 1		
FREQUENCY RANGE	1-6 GHz	DETECTOR FUNCTION & BANDWIDTH	Peak/Average, 1MHz
ENVIRONMENTAL CONDITIONS	19deg. C, 83% RH,	TESTED BY: Vincent Chen	

ANTENNA POLARITY & TEST DISTANCE: HORIZONTAL AT 3 M								
No.	Freq. (MHz)	Emission Level (dBuV/m)	Limit (dBuV/m)	Margin (dB)	Antenna Height (m)	Table Angle (Degree)	Raw Value (dBuV)	Correction Factor (dB/m)
1	1026.07	53.19 PK	70.00	-16.81	1.56 H	144	26.91	26.28
2	1026.07	35.57 AV	50.00	-14.43	1.56 H	144	9.29	26.28
3	1329.03	53.76 PK	70.00	-16.24	1.25 H	215	26.31	27.45
4	1329.03	37.52 AV	50.00	-12.48	1.25 H	215	10.07	27.45
5	2224.96	45.60 PK	70.00	-24.40	1.11 H	221	14.37	31.23
6	2224.96	31.38 AV	50.00	-18.62	1.11 H	221	0.15	31.23

REMARKS:

1. Emission level(dBuV/m)=Raw Value(dBuV) + Correction Factor(dB/m)
2. Correction Factor(dB/m) = Antenna Factor (dB/m) + Cable Factor (dB)
3. The other emission levels were very low against the limit.
4. Margin value = Emission level – Limit value.

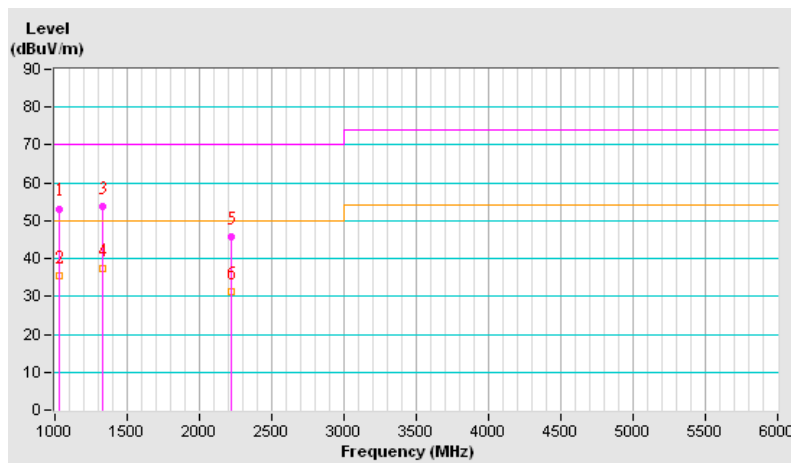



A D T

TEST MODE	Mode 1		
FREQUENCY RANGE	1-6 GHz	DETECTOR FUNCTION & BANDWIDTH	Peak/Average, 1MHz
ENVIRONMENTAL CONDITIONS	19deg. C, 83% RH,	TESTED BY: Vincent Chen	

ANTENNA POLARITY & TEST DISTANCE: VERTICAL AT 3 M

No.	Freq. (MHz)	Emission Level (dBuV/m)	Limit (dBuV/m)	Margin (dB)	Antenna Height (m)	Table Angle (Degree)	Raw Value (dBuV)	Correction Factor (dB/m)
1	1026.25	52.58 PK	70.00	-17.42	1.23 V	345	26.29	26.29
2	1026.25	43.31 AV	50.00	-6.69	1.23 V	345	17.02	26.29
3	1539.07	49.86 PK	70.00	-20.14	1.00 V	327	21.56	28.30
4	1539.07	30.15 AV	50.00	-19.85	1.00 V	327	1.85	28.30
5	1787.83	47.11 PK	70.00	-22.89	1.58 V	125	17.50	29.61
6	1787.83	29.91 AV	50.00	-20.09	1.58 V	125	0.30	29.61

REMARKS:

1. Emission level(dBuV/m)=Raw Value(dBuV) + Correction Factor(dB/m)
2. Correction Factor(dB/m) = Antenna Factor (dB/m) + Cable Factor (dB)
3. The other emission levels were very low against the limit.
4. Margin value = Emission level – Limit value.

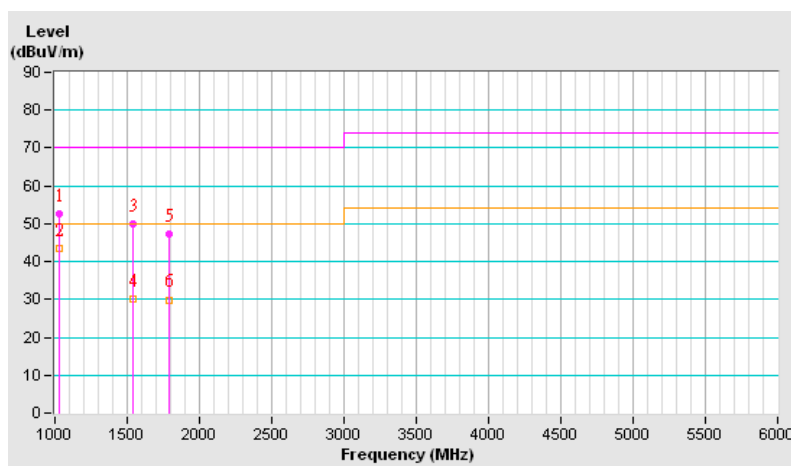

4.2.8 TEST RESULTS (2)

TEST MODE	Mode 2		
FREQUENCY RANGE	30-1000 MHz	DETECTOR FUNCTION & BANDWIDTH	Quasi-Peak, 120 kHz
ENVIRONMENTAL CONDITIONS	22deg. C, 75% RH,	TESTED BY: Hermes Lin	

ANTENNA POLARITY & TEST DISTANCE: HORIZONTAL AT 10 M

No.	Freq. (MHz)	Emission Level (dBuV/m)	Limit (dBuV/m)	Margin (dB)	Antenna Height (m)	Table Angle (Degree)	Raw Value (dBuV)	Correction Factor (dB/m)
1	71.76	20.80 QP	30.00	-9.20	4.00 H	142	8.32	12.48
2	148.36	25.78 QP	30.00	-4.22	4.00 H	210	10.59	15.19
3	174.81	21.78 QP	30.00	-8.22	4.00 H	127	7.70	14.08
4	187.07	24.74 QP	30.00	-5.26	4.00 H	231	11.65	13.09
5	229.47	21.84 QP	30.00	-8.16	4.00 H	152	8.49	13.35
6	248.27	31.62 QP	37.00	-5.38	4.00 H	253	17.40	14.22
7	296.71	25.50 QP	37.00	-11.50	4.00 H	113	8.86	16.64
8	445.06	23.66 QP	37.00	-13.34	1.50 H	232	2.84	20.82
9	741.75	32.40 QP	37.00	-4.60	1.15 H	205	5.35	27.05
10	891.00	29.94 QP	37.00	-7.06	1.50 H	211	0.63	29.31

REMARKS:

1. Emission level(dBuV/m)=Raw Value(dBuV) + Correction Factor(dB/m)
2. Correction Factor(dB/m) = Antenna Factor (dB/m) + Cable Factor (dB)
3. The other emission levels were very low against the limit.
4. Margin value = Emission level – Limit value.

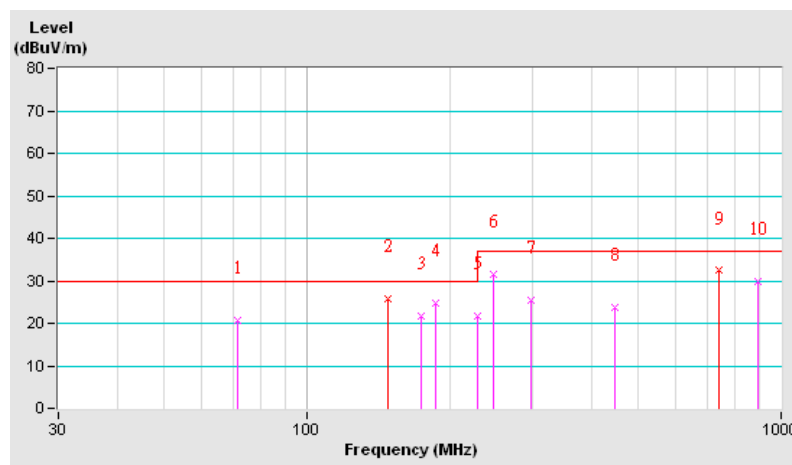



A D T

TEST MODE	Mode 2		
FREQUENCY RANGE	30-1000 MHz	DETECTOR FUNCTION & BANDWIDTH	Quasi-Peak, 120 kHz
ENVIRONMENTAL CONDITIONS	22deg. C, 75% RH,	TESTED BY: Hermes Lin	

ANTENNA POLARITY & TEST DISTANCE: VERTICAL AT 10 M

No.	Freq. (MHz)	Emission Level (dBuV/m)	Limit (dBuV/m)	Margin (dB)	Antenna Height (m)	Table Angle (Degree)	Raw Value (dBuV)	Correction Factor (dB/m)
1	75.24	20.71 QP	30.00	-9.29	1.00 V	53	9.20	11.51
2	128.00	25.76 QP	30.00	-4.24	1.00 V	211	12.62	13.14
3	141.63	24.00 QP	30.00	-6.00	1.14 V	360	9.68	14.32
4	148.36	25.24 QP	30.00	-4.76	1.00 V	108	10.05	15.19
5	151.39	24.15 QP	30.00	-5.85	1.00 V	120	8.81	15.34
6	192.01	22.81 QP	30.00	-7.19	1.00 V	0	10.14	12.67
7	229.47	24.30 QP	30.00	-5.70	1.00 V	37	10.95	13.35
8	445.05	24.33 QP	37.00	-12.67	4.00 V	176	3.51	20.82
9	485.10	23.21 QP	37.00	-13.79	3.49 V	19	1.24	21.97
10	741.76	32.85 QP	37.00	-4.15	3.99 V	140	5.80	27.05
11	890.12	29.34 QP	37.00	-7.66	1.00 V	265	0.04	29.30

REMARKS:

1. Emission level(dBuV/m)=Raw Value(dBuV) + Correction Factor(dB/m)
2. Correction Factor(dB/m) = Antenna Factor (dB/m) + Cable Factor (dB)
3. The other emission levels were very low against the limit.
4. Margin value = Emission level – Limit value.

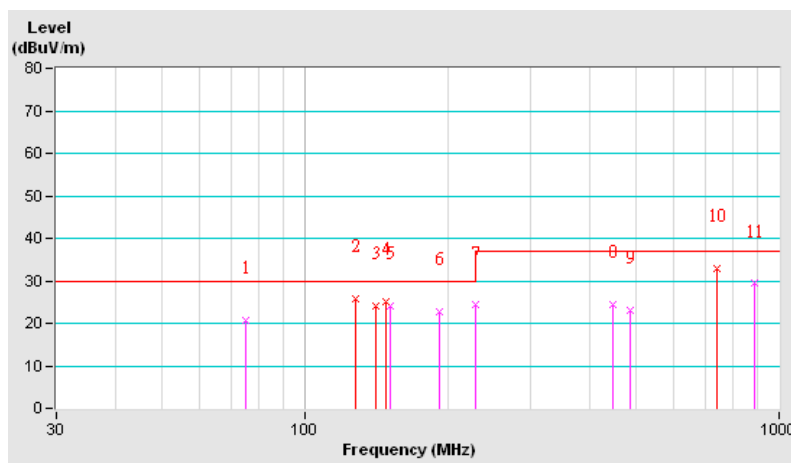



A D T

TEST MODE	Mode 2		
FREQUENCY RANGE	1-6 GHz	DETECTOR FUNCTION & BANDWIDTH	Peak/Average, 1MHz
ENVIRONMENTAL CONDITIONS	19deg. C, 83% RH,	TESTED BY: Vincent Chen	

ANTENNA POLARITY & TEST DISTANCE: HORIZONTAL AT 3 M

No.	Freq. (MHz)	Emission Level (dBuV/m)	Limit (dBuV/m)	Margin (dB)	Antenna Height (m)	Table Angle (Degree)	Raw Value (dBuV)	Correction Factor (dB/m)
1	1221.55	45.64 PK	70.00	-24.36	1.68 H	62	18.61	27.03
2	1221.55	27.57 AV	50.00	-22.43	1.68 H	62	0.54	27.03
3	1344.28	51.73 PK	70.00	-18.27	1.22 H	144	24.22	27.51
4	1344.28	32.76 AV	50.00	-17.24	1.22 H	144	5.25	27.51
5	2239.99	59.34 PK	70.00	-10.66	1.01 H	133	28.07	31.27
6	2239.99	40.66 AV	50.00	-9.34	1.01 H	133	9.39	31.27

REMARKS:

1. Emission level(dBuV/m)=Raw Value(dBuV) + Correction Factor(dB/m)
2. Correction Factor(dB/m) = Antenna Factor (dB/m) + Cable Factor (dB)
3. The other emission levels were very low against the limit.
4. Margin value = Emission level – Limit value.

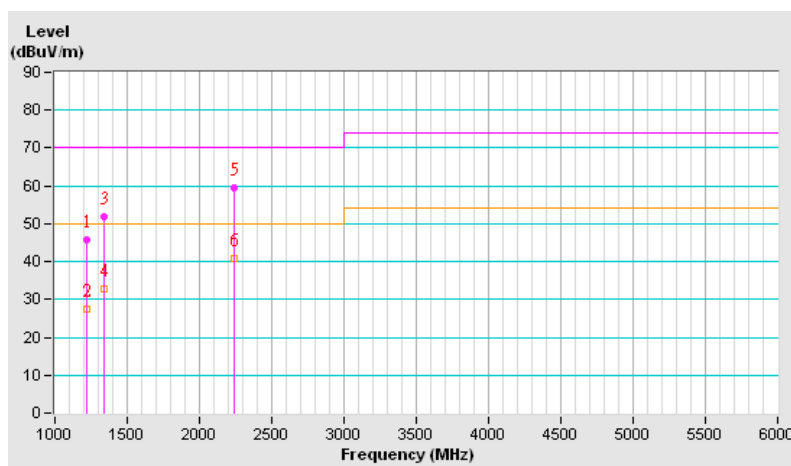



A D T

TEST MODE	Mode 2		
FREQUENCY RANGE	1-6 GHz	DETECTOR FUNCTION & BANDWIDTH	Peak/Average, 1MHz
ENVIRONMENTAL CONDITIONS	19deg. C, 83% RH,	TESTED BY: Vincent Chen	

ANTENNA POLARITY & TEST DISTANCE: VERTICAL AT 3 M								
No.	Freq. (MHz)	Emission Level (dBuV/m)	Limit (dBuV/m)	Margin (dB)	Antenna Height (m)	Table Angle (Degree)	Raw Value (dBuV)	Correction Factor (dB/m)
1	1026.00	49.66 PK	70.00	-20.34	1.21 V	9	23.38	26.28
2	1026.00	45.46 AV	50.00	-4.54	1.21 V	9	19.18	26.28
3	1575.25	42.30 PK	70.00	-27.70	1.11 V	221	13.82	28.48
4	1575.25	28.55 AV	50.00	-21.45	1.11 V	221	0.07	28.48
5	2239.95	61.74 PK	70.00	-8.26	1.42 V	180	30.47	31.27
6	2239.95	37.04 AV	50.00	-12.96	1.42 V	180	5.77	31.27

REMARKS:

1. Emission level(dBuV/m)=Raw Value(dBuV) + Correction Factor(dB/m)
2. Correction Factor(dB/m) = Antenna Factor (dB/m) + Cable Factor (dB)
3. The other emission levels were very low against the limit.
4. Margin value = Emission level – Limit value.

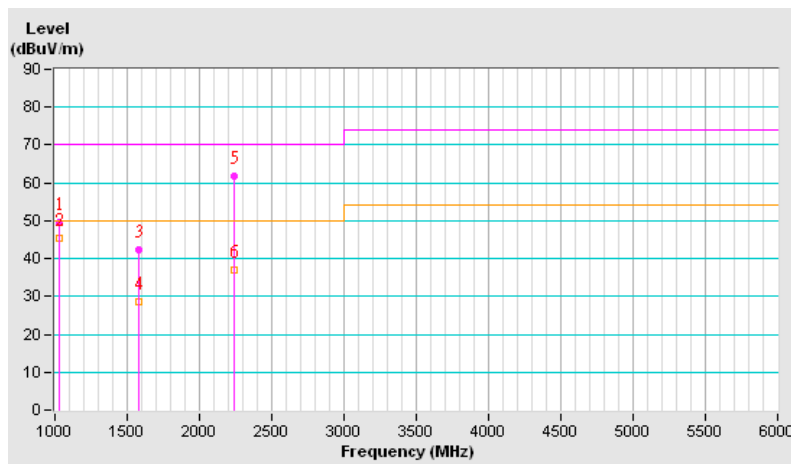

4.3 HARMONICS CURRENT MEASUREMENT

4.3.1 LIMITS OF HARMONICS CURRENT MEASUREMENT

TEST STANDARD: EN 61000-3-2

Limits for Class A equipment		Limits for Class D equipment		
Harmonics Order n	Max. permissible harmonics current A	Harmonics Order n	Max. permissible harmonics current per watt mAW	Max. permissible harmonics current A
Odd harmonics		Odd Harmonics only		
3	2.30	3	3.4	2.30
5	1.14	5	1.9	1.14
7	0.77	7	1.0	0.77
9	0.40	9	0.5	0.40
11	0.33	11	0.35	0.33
13	0.21	13	0.30	0.21
15<=n<=39	0.15x15/n	15<=n<=39	3.85/n	0.15x15/n
Even harmonics				
2	1.08			
4	0.43			
6	0.30			
8<=n<=40	0.23x8/n			

NOTE: 1. Class A and Class D are classified according to section 5 of EN 61000-3-2: 2006.

2. According to section 7 of EN 61000-3-2: 2006, the above limits for all equipment except for lighting equipment are for all applications having an active input power > 75 W and no limits apply for equipment with an active input power up to and including 75 W.

4.3.2 TEST INSTRUMENTS

DESCRIPTION & MANUFACTURER	MODEL NO.	SERIAL NO.	CALIBRATED DATE	CALIBRATED UNTIL
EMC PARTNER EMC Emission Tester	HAR1000-1P	084	Apr. 10, 2012	Apr. 09, 2013
Software	HARCS	NA	NA	NA

NOTE: 1. The test was performed in EMS Room No. 1.

2. The calibration interval of the above test instruments is 12 months and the calibrations are traceable to NML/ROC and NIST/USA.

3. According to IEC 61000-4-7: 2002, the time window shall be synchronized with each group of 10 or 12 cycles (200 ms) for power frequency of 50 or 60Hz.

4. Tested Date: Dec. 28, 2012

4.3.3 TEST PROCEDURE

- a. The EUT was placed on the top of a wooden table 0.8 meters above the ground and operated to produce the maximum harmonic components under normal operating conditions for each successive harmonic component in turn.
- b. The classification of EUT is according to section 5 of EN 61000-3-2: 2006.

The EUT is classified as follows:

Class A: Balanced three-phase equipment, Household appliances excluding equipment as Class D, Tools excluding portable tools, Dimmers for incandescent lamps, audio equipment, equipment not specified in one of the three other classes.

Class B: Portable tools. ; Arc welding equipment which is not professional equipment

Class C: Lighting equipment.

Class D: Equipment having a specified power less than or equal to 600 W of the following types: Personal computers and personal computer monitors.

- c. The correspondent test program of test instrument to measure the current harmonics emanated from EUT is chosen. The measure time shall be not less than the time necessary for the EUT to be exercised.

4.3.4 DEVIATION FROM TEST STANDARD

No deviation

4.3.5 TEST SETUP

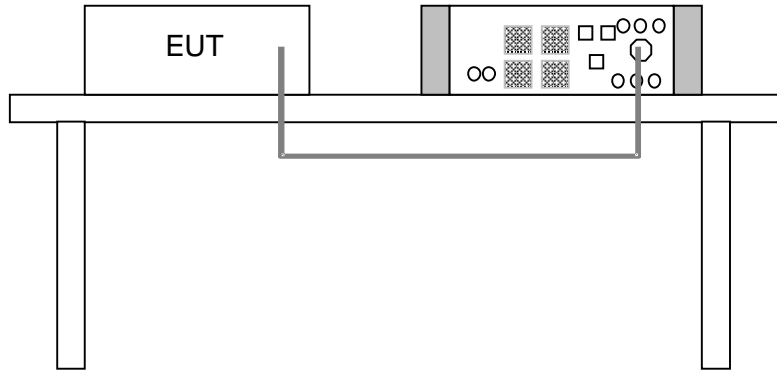

For the actual test configuration, please refer to the related item – Photographs of the Test Configuration.

4.3.6 EUT OPERATING CONDITIONS

- a. Turned on the power of all equipment.
- b. PC ran a test program to enable all functions.
- c. PC read and wrote messages from HDD.
- d. PC sent “full white screen pattern” to EUT, and then EUT displayed them on its screen.
- e. PC sent ”1kHz audio signal” to int. speaker of EUT.
- f. Steps c-f were repeated.

4.3.7 TEST RESULTS

TEST MODE	Mode 1		
FUNDAMENTAL VOLTAGE/AMPERE	230.3Vrms/ 0.228Arms	POWER FREQUENCY	50.000Hz
POWER CONSUMPTION	22.58W	POWER FACTOR	0.431
ENVIRONMENTAL CONDITIONS	23deg. C, 65%RH	TESTED BY: Ken Chen	

- NOTE :**
1. Limits are not specified for equipment with a rated power of 75W or less (other than lighting equipment).
 2. According to EN 61000-3-2 the manufacturer shall specify the power of the apparatus. This value shall be used for establishing limits. The specified power shall be within +/-10% of the measured power.

4.4 VOLTAGE FLUCTUATION AND FLICKS MEASUREMENT

4.4.1 LIMITS OF VOLTAGE FLUCTUATION AND FLICKS MEASUREMENT

TEST STANDARD: EN 61000-3-3

TEST ITEM	LIMIT	NOTE
P_{st}	1.0	P_{st} means short-term flicker indicator.
P_{lt}	0.65	P_{lt} means long-term flicker indicator.
$T_{d(t)}$ (ms)	500	$T_{d(t)}$ means maximum time that $d(t)$ exceeds 3.3%
d_{max} (%)	4	d_{max} means maximum relative voltage change.
dc (%)	3.3	dc means relative steady-state voltage change

4.4.2 TEST INSTRUMENTS

DESCRIPTION & MANUFACTURER	MODEL NO.	SERIAL NO.	CALIBRATED DATE	CALIBRATED UNTIL
EMC PARTNER EMC Emission Tester	HAR1000-1P	084	Apr. 10, 2012	Apr. 09, 2013
Software	HARCS	NA	NA	NA

- NOTE:**
1. The test was performed in EMS Room No. 1.
 2. The calibration interval of the above test instruments is 12 months and the calibrations are traceable to NML/ROC and NIST/USA.
 3. Tested Date: Dec. 28, 2012

4.4.3 TEST PROCEDURE

- a. The EUT was placed on the top of a wooden table 0.8 meters above the ground and operated to produce the most unfavorable sequence of voltage changes under normal operating conditions.
- b. During the flick measurement, the measure time shall include that part of whole operation cycle in which the EUT produce the most unfavorable sequence of voltage changes. The observation period for short-term flicker indicator is 10 minutes and the observation period for long-term flicker indicator is 2 hours.

4.4.4 DEVIATION FROM TEST STANDARD

No deviation

4.4.5 TEST SETUP

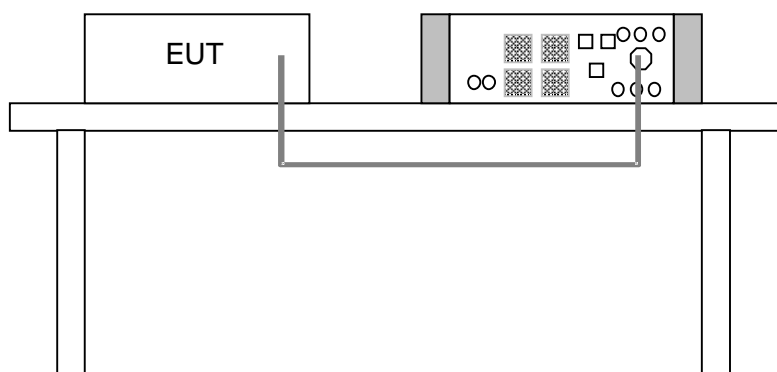

For the actual test configuration, please refer to the related item – Photographs of the Test Configuration.

4.4.6 EUT OPERATING CONDITIONS

Same as item 4.3.6



A D T

4.4.7 TEST RESULTS

TEST MODE	Mode 1		
FUNDAMENTAL VOLTAGE/AMPERE	230.3Vrms/ 0.222 Arms	POWER FREQUENCY	49.987Hz
OBSERVATION PERIOD (Tp)	10 minutes	POWER FACTOR	0.441
ENVIRONMENTAL CONDITIONS	23deg. C, 65%RH	TESTED BY: Ken Chen	

TEST PARAMETER	MEASUREMENT VALUE	LIMIT	REMARKS
P _{st}	0.072	1.0	Pass
P _{lt}	0.072	0.65	Pass
T _{d(t)} (ms)	0	500	Pass
d _{max} (%)	0	4	Pass
dc (%)	0	3.3	Pass

- NOTE:**
- (1) P_{st} means short-term flicker indicator.
 - (2) P_{lt} means long-term flicker indicator.
 - (3) T_{d(t)} means maximum time that d(t) exceeds 3.3%.
 - (4) d_{max} means maximum relative voltage change.
 - (5) dc means relative steady-state voltage change.

5.2 GENERAL PERFORMANCE CRITERIA DESCRIPTION

According to Clause 7 of EN 55024 standard, the following describes the general performance criteria.

CRITERION A	The equipment shall continue to operate as intended without operator intervention. No degradation of performance or loss of function is allowed below a performance level specified by the manufacturer when the equipment is used as intended. The performance level may be replaced by a permissible loss of performance. If the minimum performance level or the permissible performance loss is not specified by the manufacturer, then either of these may be derived from the product description and documentation, and by what the user may reasonably expect from the equipment if used as intended.
CRITERION B	After the test, the equipment shall continue to operate as intended without operator intervention. No degradation of performance or loss of function is allowed, after the application of the phenomenon below a performance level specified by the manufacturer, when the equipment is used as intended. The performance level may be replaced by a permissible loss of performance. During the test, degradation of performance is allowed. However, no change of operating state if stored data is allowed to persist after the test. If the minimum performance level (or the permissible performance loss) is not specified by the manufacturer, then either of these may be derived from the product description and documentation, and by what the user may reasonably expect from the equipment if used as intended.
CRITERION C	Loss of function is allowed, provided the function is self-recoverable, or can be restored by the operation of the controls by the user in accordance with the manufacturer's instructions. Functions, and/or information stored in non-volatile memory, or protected by a battery backup, shall not be lost.

Particular performance criteria

The particular performance criteria which are specified in the normative annexes of EN 55024 take precedence over the corresponding parts of the general performance criteria.

Where particular performance criteria for specific functions are not given, then the general performance criteria shall apply.

5.3 EUT OPERATING CONDITION

- a. Turned on the power of all equipment.
- b. PC ran a test program to enable all functions.
- c. PC read and wrote messages from HDD.
- d. PC sent "H" messages to EUT, and then EUT displayed them on its screen.
- e. PC sent "1kHz audio signal" to int. speaker of EUT.
- f. Steps c-f were repeated.

5.4 ELECTROSTATIC DISCHARGE IMMUNITY TEST (ESD)

5.4.1 TEST SPECIFICATION

Basic Standard:	IEC 61000-4-2
Discharge Impedance:	330 ohm / 150 pF
Discharge Voltage:	Air Discharge : 2kV/ 4kV/ 8kV (Direct) Contact Discharge : 2kV/ 4kV (Direct/Indirect)
Polarity:	Positive & Negative
Number of Discharge:	Air Discharge: Min. 20 times at each test point Contact Discharge: Min. 200 times in total
Discharge Mode:	Single Discharge
Discharge Period:	1 second minimum

5.4.2 TEST INSTRUMENTS

DESCRIPTION & MANUFACTURER	MODEL NO.	SERIAL NO.	CALIBRATED DATE	CALIBRATED UNTIL
KeyTek, ESD Simulator	MZ-15/EC	0504259	Jul. 05, 2012	Jul. 04, 2013

- NOTE:**
1. The test was performed in ESD Room No. 1.
 2. The calibration interval of the above test instruments is 12 months and the calibrations are traceable to NML/ROC and NIST/USA.
 3. Tested Date: Dec. 28, 2012.

5.4.3 TEST PROCEDURE

The discharges shall be applied in two ways:

- a. Contact discharges to the conductive surfaces and coupling planes:
The EUT shall be exposed to at least 200 discharges, 100 each at negative and positive polarity, at a minimum of four test points. One of the test points shall be subjected to at least 50 indirect discharges to the center of the front edge of the horizontal coupling plane. The remaining three test points shall each receive at least 50 direct contact discharges. If no direct contact test points are available, then at least 200 indirect discharges shall be applied in the indirect mode. Test shall be performed at a maximum repetition rate of one discharge per second.
- b. Air discharges at slots and apertures and insulating surfaces:
On those parts of the EUT where it is not possible to perform contact discharge testing, the equipment should be investigated to identify user accessible points where breakdown may occur. Such points are tested using the air discharge method. This investigation should be restricted to those area normally handled by the user. A minimum of 10 single air discharges shall be applied to the selected test point for each such area.

The basic test procedure was in accordance with IEC 61000-4-2:

- a. Electrostatic discharges were applied only to those points and surfaces of the EUT that are accessible to users during normal operation.
- b. The test was performed with at least ten single discharges on the pre-selected points in the most sensitive polarity.
- c. The time interval between two successive single discharges was at least 1 second.
- d. The ESD generator was held perpendicularly to the surface to which the discharge was applied and the return cable was at least 0.2 meters from the EUT.
- e. Contact discharges were applied to the non-insulating coating, with the pointed tip of the generator penetrating the coating and contacting the conducting substrate.
- f. Air discharges were applied with the round discharge tip of the discharge electrode approaching the EUT as fast as possible (without causing mechanical damage) to touch the EUT. After each discharge, the ESD generator was removed from the EUT and re-triggered for a new single discharge. The test was repeated until all discharges were complete.
- g. At least ten single discharges (in the most sensitive polarity) were applied to the **Horizontal Coupling Plane** at points on each side of the EUT. The ESD generator was positioned horizontally at a distance of 0.1 meters from the EUT with the discharge electrode touching the **HCP**.
- h. At least ten single discharges (in the most sensitive polarity) were applied to the center of one vertical edge of the **Vertical Coupling Plane** in sufficiently different positions that the four faces of the EUT were completely illuminated. The **VCP** (dimensions 0.5m x 0.5m) was placed vertically to and 0.1 meters from the EUT.

5.4.4 DEVIATION FROM TEST STANDARD

No deviation

5.4.5 TEST SETUP

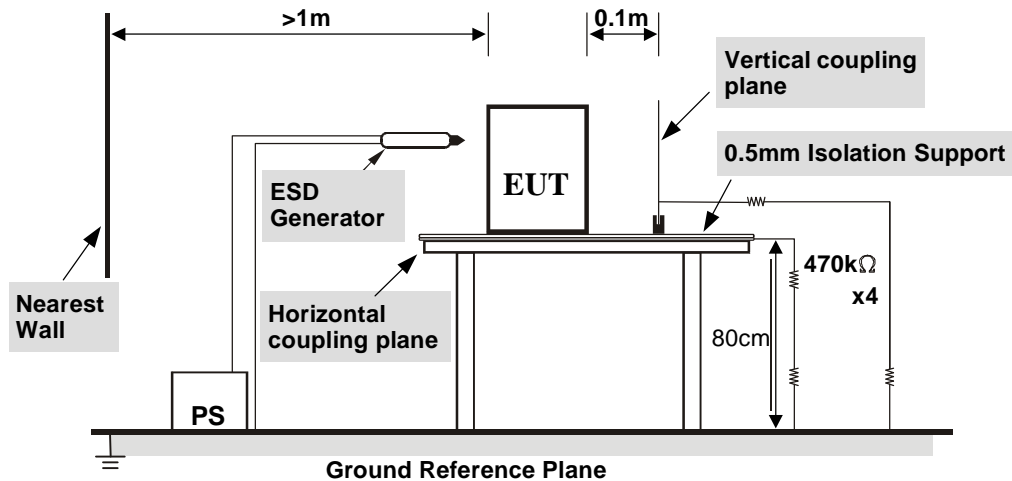

For the actual test configuration, please refer to the related item – Photographs of the Test Configuration.

NOTE:

TABLE-TOP EQUIPMENT

The configuration consisted of a wooden table 0.8 meters high standing on the **Ground Reference Plane**. The **GRP** consisted of a sheet of aluminum at least 0.25mm thick, and 2.5 meters square connected to the protective grounding system. A **Horizontal Coupling Plane** (1.6m x 0.8m) was placed on the table and attached to the **GRP** by means of a cable with 940kΩ total impedance. The equipment under test, was installed in a representative system as described in section 7 of IEC 61000-4-2, and its cables were placed on the **HCP** and isolated by an insulating support of 0.5mm thickness. A distance of 1-meter minimum was provided between the EUT and the walls of the laboratory and any other metallic structure.

FLOOR-STANDING EQUIPMENT

The equipment under test was installed in a representative system as described in section 7 of IEC 61000-4-2, and its cables were isolated from the Ground Reference Plane by an insulating support of 0.1-meter thickness. The GRP consisted of a sheet of aluminum that is at least 0.25mm thick, and 2.5 meters square connected to the protective grounding system and extended at least 0.5 meters from the EUT on all sides.

5.4.6 TEST RESULTS

TEST MODE	Mode 1	INPUT POWER	230Vac, 50 Hz
ENVIRONMENTAL CONDITIONS	21deg. C, 48%RH, 1008hPa	TESTED BY: Ryan Chen	

TEST RESULTS OF DIRECT APPLICATION					
Discharge Level (kV)	Polarity	Test Point	Contact Discharge	Air Discharge	Performance Criterion
2, 4	+/-	1	N/A	Note (1)	A
8	+/-	1	N/A	Note (2)	B
2, 4, 8	+/-	3 ~ 6	N/A	Note (1)	A
2, 4	+/-	7, 8	Note (1)	N/A	A

Description of test point: Please refer to ESD test photo for representative mark only.

TEST RESULTS OF INDIRECT APPLICATION					
Discharge Level (kV)	Polarity	Test Point	Horizontal Coupling Plane	Vertical Coupling Plane	Performance Criterion
2, 4	+/-	1 ~ 4	Note (1)	Note (1)	A

Description of test point:

1. Left side
2. Right side
3. Front side
4. Rear side

NOTE: (1) There was no change compared with initial operation during the test.

(2) There was flickered disturbance on screen during the test, but self-recoverable after the test.

5.5 RADIATED, RADIO-FREQUENCY, ELECTROMAGNETIC FIELD IMMUNITY TEST (RS)

5.5.1 TEST SPECIFICATION

Basic Standard:	IEC 61000-4-3
Frequency Range:	80 MHz - 1000 MHz
Field Strength:	3 V/m
Modulation:	1 kHz Sine Wave, 80%, AM Modulation
Frequency Step:	1 % of fundamental
Polarity of Antenna:	Horizontal and Vertical
Antenna Height:	1.5 m
Dwell Time:	3 seconds



A D T

5.5.2 TEST INSTRUMENTS

DESCRIPTION & MANUFACTURER	MODEL NO.	SERIAL NO.	CALIBRATED DATE	CALIBRATED UNTIL
Agilent Signal Generator	E8257D	MY48050465	Jul. 11, 2012	Jul. 10, 2013
PRANA RF Amplifier	AP32DP280	0811-894	NA	NA
AR RF Amplifier	150W1000M3	306601	NA	NA
AR RF Amplifier	35S4G8AM4	0326094	NA	NA
AR RF Amplifier	100S1G4M3	0329249	NA	NA
AR Controller	SC1000M3	305910	NA	NA
Radisense Electric Field Sensor	CTR1002A	08D00057SN O-07	Jun. 06, 2012	Jun. 05, 2013
BOONTON RF Voltage Meter	4232A	10180	Jun. 14, 2012	Jun. 13, 2013
BOONTON Power Sensor	51011-EMC	34152	Jun. 14, 2012	Jun. 13, 2013
BOONTON Power Sensor	51011-EMC	34153	Jun. 14, 2012	Jun. 13, 2013
AR Log-Periodic Antenna	AT6080	0329465	NA	NA
EMCO BiconiLog Antenna	3141	1001	NA	NA
AR High Gain Antenna	AT4002A	306533	NA	NA
AR High Gain Horn Antenna	AT4010	0329800	NA	NA
CHANCE MOST Full Anechoic Chamber (9x5x3m)	Chance Most	RS-002	Feb. 10, 2012	Feb. 09, 2013
Software	ADT_RS_V7.6	NA	NA	NA

- NOTE:** 1. The test was performed in RS Room No.2.
2. The calibration interval of the above test instruments is 12 months and the calibrations are traceable to NML/ROC and NIST/USA.
3. The transmit antenna was located at a distance of 3 meters from the EUT.
4. Tested Date: Dec. 28, 2012

5.5.3 TEST PROCEDURE

The test procedure was in accordance with IEC 61000-4-3

- a. The testing was performed in a fully-anechoic chamber.
- b. The frequency range is swept from 80 MHz to 1000 MHz with the signal 80% amplitude modulated with a 1kHz sine wave.
- c. The dwell time at each frequency shall not be less than the time necessary for the EUT to be exercised and to respond, but shall in no case be less than 0,5s.
- d. The field strength level was 3V/m.
- e. The test was performed with the EUT exposed to both vertically and horizontally polarized fields on each of the four sides.

5.5.4 DEVIATION FROM TEST STANDARD

No deviation

5.5.5 TEST SETUP

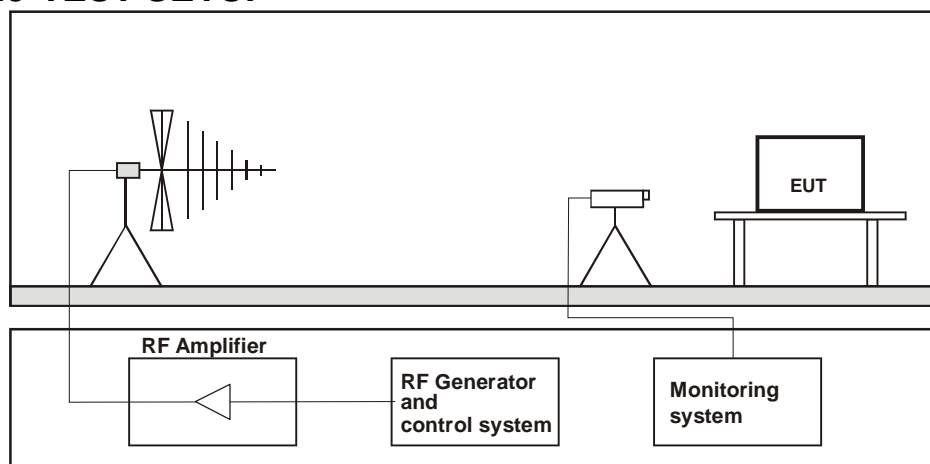

For the actual test configuration, please refer to the related item – Photographs of the Test Configuration.

NOTE:

TABLETOP EQUIPMENT

The EUT installed in a representative system as described in section 7 of IEC 61000-4-3 was placed on a non-conductive table 0.8 meters in height. The system under test was connected to the power and signal wire according to relevant installation instructions.

FLOOR STANDING EQUIPMENT

The EUT installed in a representative system as described in section 7 of IEC 61000-4-3 was placed on a non-conductive wood support 0.1 meters in height. The system under test was connected to the power and signal wire according to relevant installation instructions.

5.5.6 TEST RESULTS

TEST MODE	Mode 1	INPUT POWER	230Vac, 50 Hz
ENVIRONMENTAL CONDITIONS	23deg. C, 67%RH	TESTED BY: Ken Chen	

Frequency (MHz)	Polarity	Azimuth	Field Strength (V/m)	Observation	Performance Criterion
80 - 1000	V & H	0	3	Note	A
	V & H	90	3		
	V & H	180	3		
	V & H	270	3		

NOTE: There was no change compared with the initial operation during the test.

5.6 ELECTRICAL FAST TRANSIENT/BURST IMMUNITY TEST (EFT)

5.6.1 TEST SPECIFICATION

Basic Standard:	IEC 61000-4-4
Test Voltage:	Power Line : 1 kV Signal Line : N/A
Polarity:	Positive & Negative
Impulse Frequency:	100 kHz: only for signal lines of xDSL equipment 5 kHz: except for xDSL equipment
Impulse Waveshape :	5/50 ns
Burst Duration:	15 ms
Burst Period:	300 ms
Test Duration:	1 min.

5.6.2 TEST INSTRUMENTS

DESCRIPTION & MANUFACTURER	MODEL NO.	SERIAL NO.	CALIBRATED DATE	CALIBRATED UNTIL
Haefely, EFT Generator	PEFT 4010	154954	Apr. 26, 2012	Apr. 25, 2013
Haefely, Capacitive Clamp	IP4A	155173	NA	NA

- NOTE:**
1. The test was performed in EFT Room
 2. The calibration interval of the above test instruments is 12 months and the calibrations are traceable to NML/ROC and NIST/USA.
 3. Tested Date: Dec. 28, 2012.

5.6.3 TEST PROCEDURE

- a. Both positive and negative polarity discharges were applied.
- b. The distance between any coupling devices and the EUT should be (0.5 – 0/+0.1) m for table-top equipment testing, and (1.0 ± 0.1) m for floor standing equipment.
- c. The duration time of each test sequential was 1 minute.
- d. The transient/burst waveform was in accordance with IEC 61000-4-4, 5/50ns.

5.6.4 DEVIATION FROM TEST STANDARD

No deviation

5.6.5 TEST SETUP

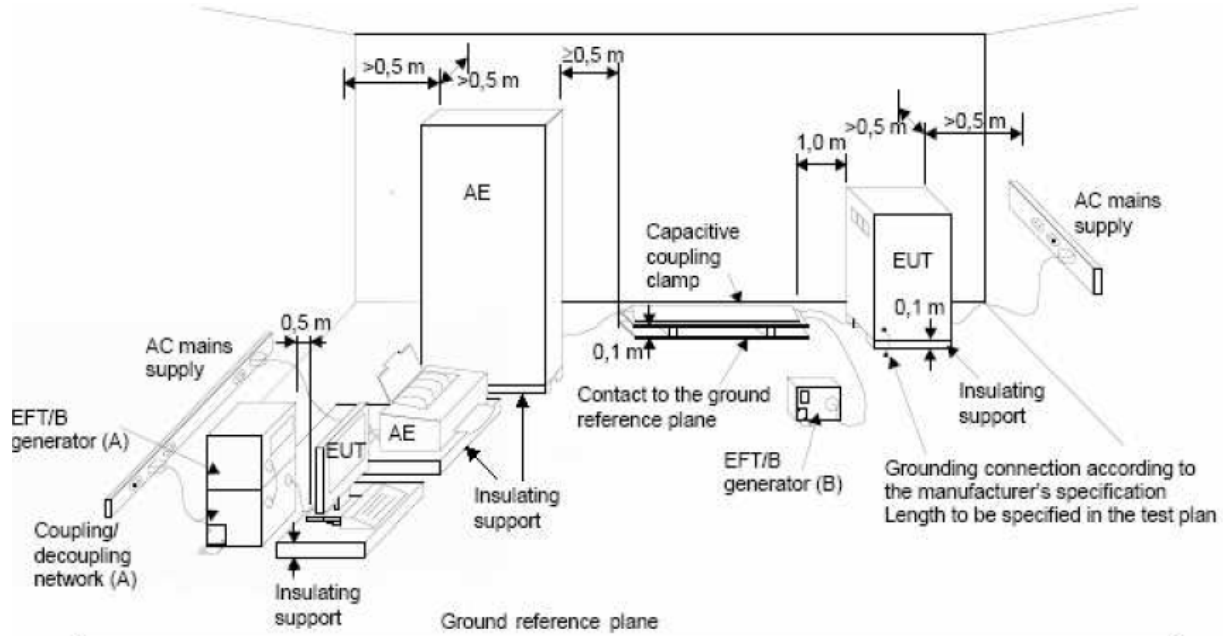

NOTE:

- (A) location for supply line coupling
- (B) location for signal lines coupling

For the actual test configuration, please refer to the related item – Photographs of the Test Configuration.

5.6.6 TEST RESULTS

TEST MODE	Mode 1	INPUT POWER	230Vac, 50 Hz
ENVIRONMENTAL CONDITIONS	23deg. C, 67%RH	TESTED BY: Ken Chen	

Test Point	Polarity	Test Level (kV)	Observation	Performance Criterion
L1	+/-	1	Note	A
L2	+/-	1	Note	A
PE	+/-	1	Note	A
L1-L2-PE	+/-	1	Note	A

NOTE: There was no change compared with the initial operation during the test.

5.7 SURGE IMMUNITY TEST

5.7.1 TEST SPECIFICATION

Basic Standard:	IEC 61000-4-5
Wave-Shape:	Combination Wave for power lines 1.2/50 us Open Circuit Voltage 8 /20 us Short Circuit Current 10/700 us Wave for signal lines 10/700 us Open Circuit Voltage
Test Voltage:	Power Line : 0.5kV/ 1 kV/ 2 kV
Generator Source	2 ohm between networks
Impedance:	12 ohm between network and ground
Polarity:	Positive/Negative
Phase Angle:	0° /90°/180°/270°
Pulse Repetition Rate:	1 time / 20 sec.
Number of Tests:	5 positive and 5 negative at selected points

5.7.2 TEST INSTRUMENTS

DESCRIPTION & MANUFACTURER	MODEL NO.	SERIAL NO.	CALIBRATED DATE	CALIBRATED UNTIL
NoiseKen Surge Generator	LSS-15AX-C3 A	LSS1071126	Oct. 22, 2012	Oct. 21, 2013
Coupling Decoupling Network	CDN-UTP8	045	Aug. 01, 2012	Jul. 31, 2013
Surge Cable	WE-4	SU1Cab-001	NA	NA
Surge Adapter WONPRO	WA-9	SU1ADA-002	NA	NA

- NOTE:**
1. The test was performed in Surge Room.
 2. The calibration interval of the above test instruments is 12 months and the calibrations are traceable to NML/ROC and NIST/USA.
 3. Tested Date: Dec. 28, 2012.

5.7.3 TEST PROCEDURE

- a. For EUT power supply:

The surge is to be applied to the EUT power supply terminals via the capacitive coupling network. Decoupling networks are required in order to avoid possible adverse effects on equipment not under test that may be powered by the same lines, and to provide sufficient decoupling impedance to the surge wave. The power cord between the EUT and the coupling/decoupling networks shall be 2 meters in length (or shorter).

- b. For test applied to unshielded unsymmetrically operated interconnection lines of EUT:

The surge is applied to the lines via the capacitive coupling. The coupling / decoupling networks shall not influence the specified functional conditions of the EUT. The interconnection line between the EUT and the coupling/decoupling networks shall be 2 meters in length (or shorter).

- c. For test applied to unshielded symmetrically operated interconnection / telecommunication lines of EUT:

The surge is applied to the lines via gas arrestors coupling. Test levels below the ignition point of the coupling arrestor cannot be specified. The interconnection line between the EUT and the coupling/decoupling networks shall be 2 meters in length (or shorter).

5.7.4 DEVIATION FROM TEST STANDARD

No deviation

5.7.5 TEST SETUP

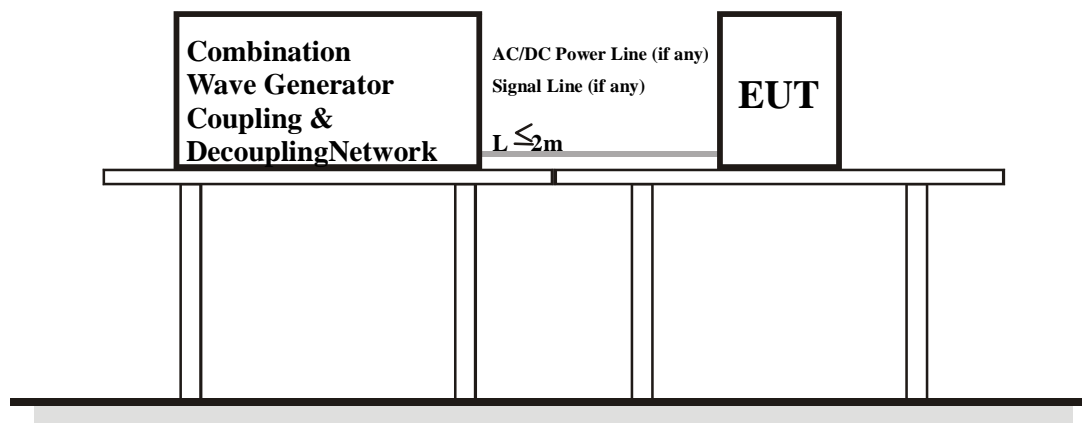

For the actual test configuration, please refer to the related item – Photographs of the Test Configuration.

5.7.6 TEST RESULTS

TEST MODE	Mode 1	INPUT POWER	230Vac, 50 Hz
ENVIRONMENTAL CONDITIONS	23deg. C, 67%RH	TESTED BY: Ken Chen	

Voltage (kV)	Test Point	Polarity	Phase Angle				Performance Criterion
			0°	90°	180°	270°	
0.5, 1	L1-L2	+/-	Note	Note	Note	Note	A
0.5, 1, 2	L1-PE	+/-	Note	Note	Note	Note	A
	L2-PE	+/-	Note	Note	Note	Note	A

NOTE: There was no change compared with the initial operation during the test.

5.8 IMMUNITY TO CONDUCTED DISTURBANCES INDUCED BY RF FIELDS (CS)

5.8.1 TEST SPECIFICATION

Basic Standard:	IEC 61000-4-6
Frequency Range:	0.15 MHz - 80 MHz
Field Strength:	3 V _{r.m.s.}
Modulation:	1kHz Sine Wave, 80%, AM Modulation
Frequency Step:	1 % of fundamental
Coupling Device:	CDN-M3



A D T

5.8.2 TEST INSTRUMENTS

DESCRIPTION & MANUFACTURER	MODEL NO.	SERIAL NO.	CALIBRATED DATE	CALIBRATED UNTIL
ROHDE & SCHWARZ Signal Generator	SMY01	841104/033	Nov. 20, 2012	Nov. 19, 2013
Digital Sweep Function Generator	8120	984801	NA	NA
AR Power Amplifier	75A250AM 1	312196	NA	NA
FCC Coupling Decoupling Network	FCC-801-M 3-25A	48	Aug. 17, 2012	Aug. 16, 2013
FCC Coupling Decoupling Network	FCC-801-M 3-25A	01022	Feb. 24, 2012	Feb. 23, 2013
FCC Coupling Decoupling Network	FCC-801-M 2-16A	01047	Aug. 17, 2012	Aug. 16, 2013
FISCHER CUSTOM COMMUNICATIONS EM Injection Clamp	FCC-203I	50	NA	NA
FISCHER CUSTOM COMMUNICATIONS Current Injection Clamp	F-120-9A	361	NA	NA
EM TEST Coupling Decoupling Network	CDN M1/32A	306508	Feb. 24, 2012	Feb. 23, 2013
FCC Coupling Decoupling Network	FCC-801-T 8	02038	Feb. 24, 2012	Feb. 23, 2013
FCC Coupling Decoupling Network	FCC-801-T 4	02031	Feb. 24, 2012	Feb. 23, 2013
FCC Coupling Decoupling Network	FCC-801-T 2	02021	Feb. 24, 2012	Feb. 23, 2013
R&S Power Sensor	NRV-Z5	837878/038	Nov. 02, 2012	Nov. 01, 2013
R&S Power Sensor	NRV-Z5	837878/039	Nov. 02, 2012	Nov. 01, 2013
R&S Power Meter	NRVD	837794/040	Nov. 02, 2012	Nov. 01, 2013
Software	ADT_CS_V 7.4.2	NA	NA	NA

- NOTE:** 1. The test was performed in CS Room No. 1.
2. The calibration interval of the above test instruments is 12 months and the calibrations are traceable to NML/ROC and NIST/USA.
3. Tested Date: Dec. 28, 2012.

5.8.3 TEST PROCEDURE

- a. The EUT shall be tested within its intended operating and climatic conditions.
- b. An artificial hand was placed on the hand-held accessory and connected to the ground reference plane.
- c. One of the CDNs not used for injection was terminated with 50Ω , providing only one return path. All other CDNs were coupled as decoupling networks.
- d. The frequency range is swept from 150 kHz to 80 MHz, using the signal level established during the setting process and with a disturbance signal of 80 % amplitude. The signal is modulated with a 1 kHz sine wave, pausing to adjust the RF signal level or the switch coupling devices as necessary. Where the frequency is swept incrementally, the step size shall not exceed 1 % of the preceding frequency value.
- e. The dwell time of the amplitude modulated carrier at each frequency shall not be less than the time necessary for the EUT to be exercised and to respond, but shall in no case be less than 0,5 s. The sensitive frequencies (e.g. clock frequencies) shall be analyzed separately.
- f. Attempts should be made to fully exercise the EUT during testing, and to fully interrogate all exercise modes selected for susceptibility.

5.8.4 DEVIATION FROM TEST STANDARD

No deviation

5.8.5 TEST SETUP

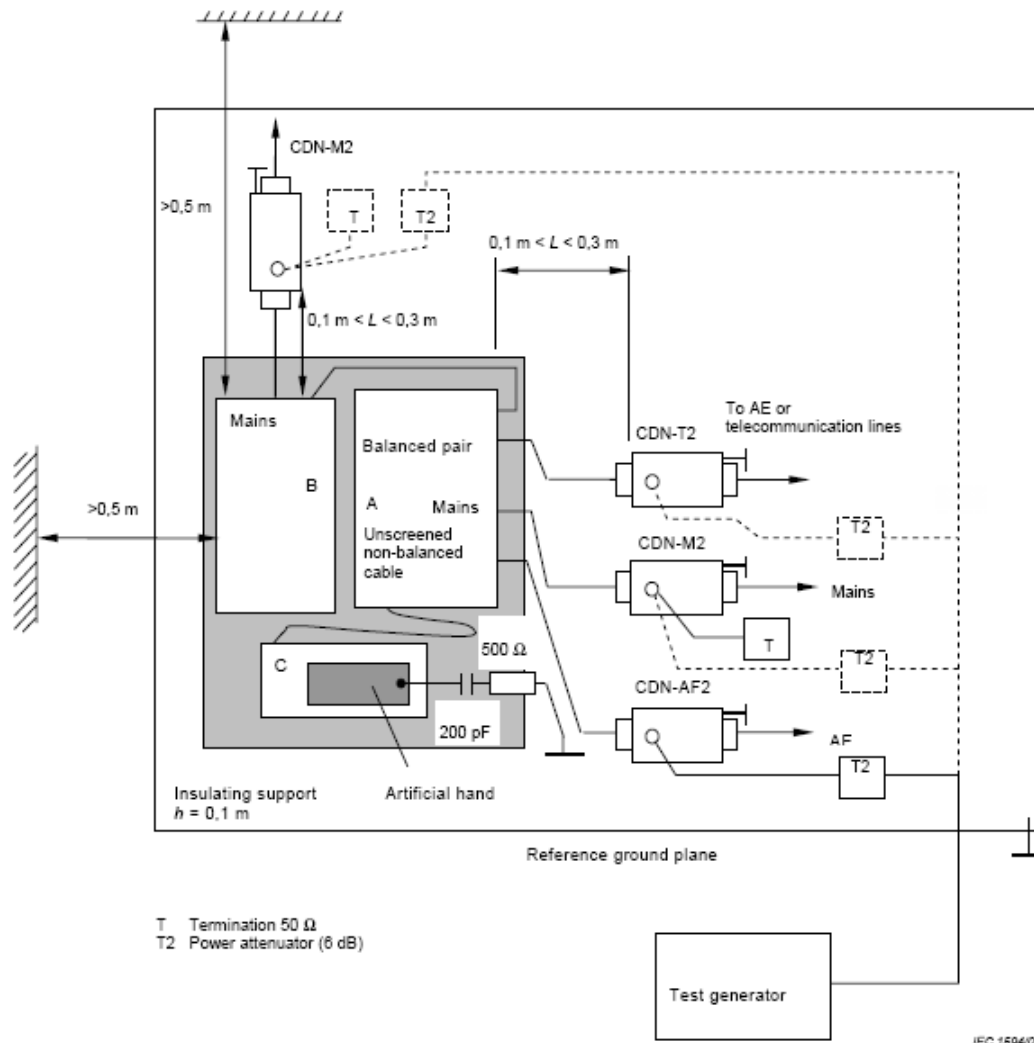

For the actual test configuration, please refer to the related item – Photographs of the Test Configuration.

- Note:**
1. The EUT clearance from any metallic obstacles shall be at least 0,5 m.
 2. Interconnecting cables (≤ 1 m) belonging to the EUT shall remain on the insulating support.
 3. The equipment to be tested is placed on an insulating support of 0.1 meters height above a ground reference plane. All relevant cables shall be provided with the appropriate coupling and decoupling devices at a distance between 0.1 meters and 0.3 meters from the projected geometry of the EUT on the ground reference plane.

5.8.6 TEST RESULTS

TEST MODE	Mode 1	INPUT POWER	230Vac, 50 Hz
ENVIRONMENTAL CONDITIONS	22deg. C, 65%RH	TESTED BY: Ken Chen	

FREQUENCY (MHz)	FIELD STRENGTH (V _{r.m.s.})	CABLE	INJECTION METHOD	RETURN PATH	OBSER- VATION	PERFORMANCE CRITERION
0.15 – 80	3	AC power line	CDN-M3	CDN-M3	Note	A

NOTE: There was no change compared with the initial operation during the test.

5.9 POWER FREQUENCY MAGNETIC FIELD IMMUNITY TEST

5.9.1 TEST SPECIFICATION

Basic Standard:	IEC 61000-4-8
Frequency Range:	50Hz
Field Strength:	1 A/m
Observation Time:	1 minute
Inductance Coil:	Rectangular type, 1 m x 1 m

5.9.2 TEST INSTRUMENTS

DESCRIPTION & MANUFACTURER	MODEL NO.	SERIAL NO.	CALIBRATED DATE	CALIBRATED UNTIL
HAEFELY Magnetic Field Tester	MAG 100.1	083794-06	NA	NA
COMBINOVA Magnetic Field Meter	MFM10	224	Apr. 12, 2012	Apr. 11, 2013

- NOTE:**
1. The test was performed in EMS Room No. 1.
 2. The calibration interval of the above test instruments is 12 months and the calibrations are traceable to NML/ROC and NIST/USA.
 3. Tested Date: Dec. 28, 2012

5.9.3 TEST PROCEDURE

- a. The equipment is configured and connected to satisfy its functional requirements.
- b. The power supply, input and output circuits shall be connected to the sources of power supply, control and signal.
- c. The cables supplied or recommended by the equipment manufacturer shall be used. 1 meter of all cables used shall be exposed to the magnetic field.

5.9.4 DEVIATION FROM TEST STANDARD

No deviation

5.9.5 TEST SETUP

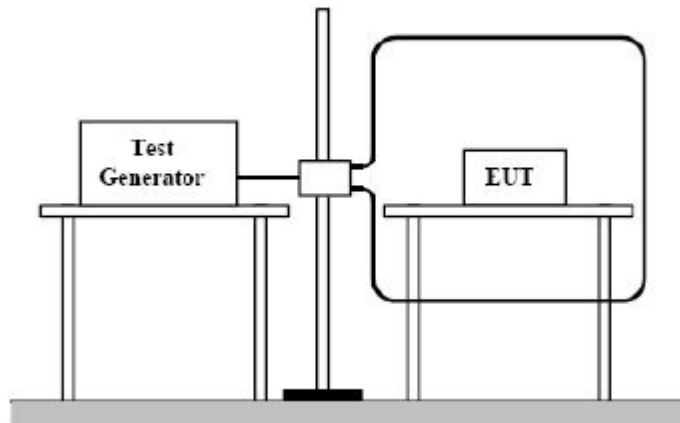

For the actual test configuration, please refer to the related item – Photographs of the Test Configuration.

NOTE:

TABLETOP EQUIPMENT

The equipment shall be subjected to the test magnetic field by using the induction coil of standard dimension (1 m x 1 m). The induction coil shall then be rotated by 90 degrees in order to expose the EUT to the test field with different orientations.

FLOOR-STANDING EQUIPMENT

The equipment shall be subjected to the test magnetic field by using induction coils of suitable dimensions. The test shall be repeated by moving and shifting the induction coils, in order to test the whole volume of the EUT for each orthogonal direction. The test shall be repeated with the coil shifted to different positions along the side of the EUT, in steps corresponding to 50 % of the shortest side of the coil. The induction coil shall then be rotated by 90 degrees in order to expose the EUT to the test field with different orientations.

5.9.6 TEST RESULTS

TEST MODE	Mode 1	INPUT POWER	230Vac, 50 Hz
ENVIRONMENTAL CONDITIONS	23deg. C, 67%RH	TESTED BY: Ken Chen	

Direction	Field Strength (A/m)	Observation	Performance Criterion
X - Axis	1	Note	A
Y - Axis	1	Note	A
Z - Axis	1	Note	A

NOTE: There was no change compared with the initial operation during the test.

5.10 VOLTAGE DIP/SHORT INTERRUPTIONS (DIP) IMMUNITY TEST

5.10.1 TEST SPECIFICATION

Basic Standard:	IEC 61000-4-11
Test Duration Time:	Minimum three test events in sequence
Interval between Event:	Minimum ten seconds
Phase Angle:	0°/180°
Test Cycle:	3 times

5.10.2 TEST INSTRUMENTS

DESCRIPTION & MANUFACTURER	MODEL NO.	SERIAL NO.	CALIBRATED DATE	CALIBRATED UNTIL
HAEFELY Mains Interference Simulator	PLINE1610	083690-17	Jul. 06, 2012	Jul. 05, 2013

- NOTE:**
1. The test was performed in EMS Room No. 1.
 2. The calibration interval of the above test instruments is 12 months and the calibrations are traceable to NML/ROC and NIST/USA.
 3. Tested Date: Dec. 28, 2012

5.10.3 TEST PROCEDURE

The EUT shall be tested for each selected combination of test levels and duration with a sequence of three dips/interruptions with intervals of 10 s minimum (between each test event). Each representative mode of operation shall be tested. Abrupt changes in supply voltage shall occur at zero crossings of the voltage waveform.

5.10.4 DEVIATION FROM TEST STANDARD

No deviation

5.10.5 TEST SETUP

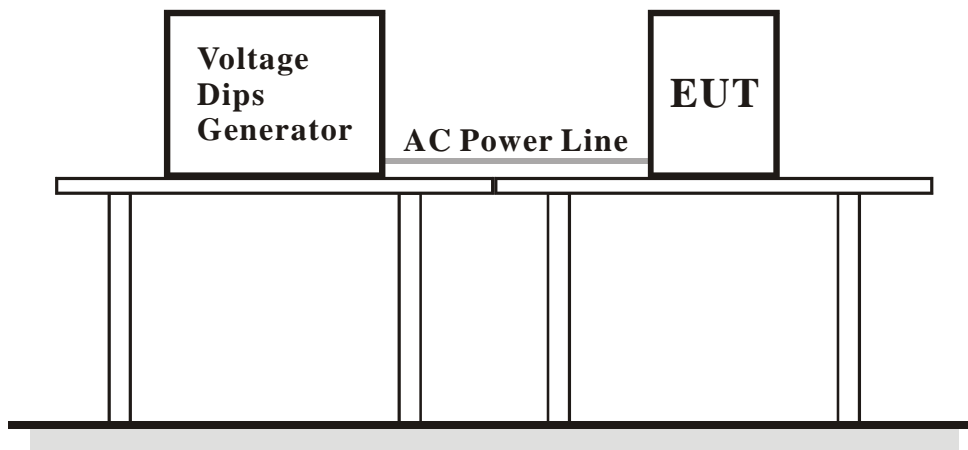

For the actual test configuration, please refer to the related item – Photographs of the Test Configuration.

5.10.6 TEST RESULTS

TEST MODE	Mode 1	INPUT POWER	230Vac, 50 Hz & 100Vac, 50 Hz
ENVIRONMENTAL CONDITIONS	23deg. C, 67%RH	TESTED BY: Ken Chen	

Input Power for testing: 230Vac, 50 Hz			
VOLTAGE % REDUCTION	PERIODS	OBSERVATION	PERFORMANCE CRITERION
>95	0.5	Note (1)	A
30	25	Note (1)	A
>95	250	Note (2)	B

Input Power for testing: 100Vac, 50 Hz			
VOLTAGE % REDUCTION	PERIODS	OBSERVATION	PERFORMANCE CRITERION
>95	0.5	Note (1)	A
30	25	Note (1)	A
>95	250	Note (2)	B

NOTE: (1) There was no change compared with the initial operation during the test.
 (2) The EUT reset during the test.

6 PHOTOGRAPHS OF THE TEST CONFIGURATION

CONDUCTED EMISSION TEST – For Mode 1



CONDUCTED EMISSION TEST – For Mode 2



RADIATED EMISSION TEST – For Mode 1 (Frequency Range 30MHz ~ 1GHz)



RADIATED EMISSION TEST – For Mode 1 (Frequency Range above 1GHz)



RADIATED EMISSION TEST – For Mode 2 (Frequency Range 30MHz ~ 1GHz)

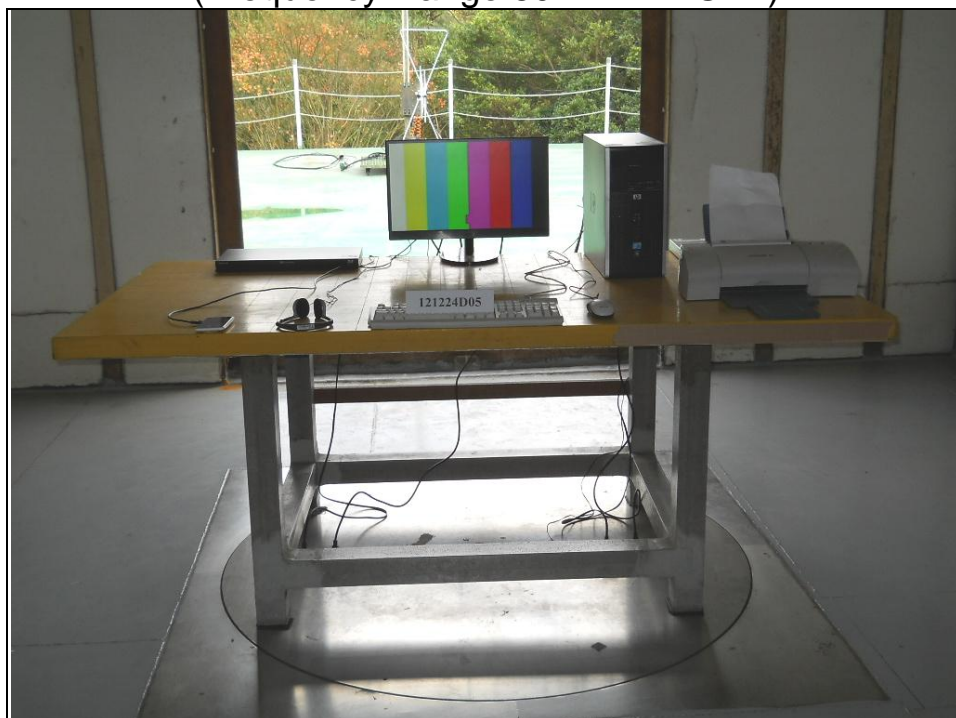

RADIATED EMISSION TEST – For Mode 2 (Frequency Range above 1GHz)





A D T

HARMONICS EMISSION TEST & VOLTAGE FLUCTUATIONS AND FLICKER TEST



ESD TEST



ESD TEST POINT

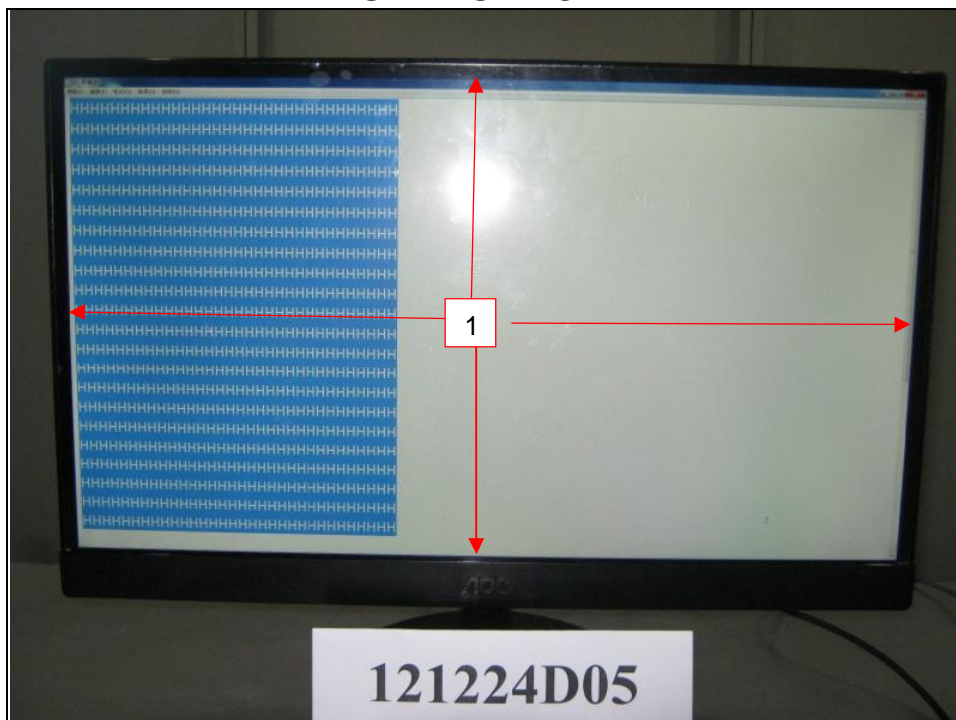

ESD TEST POINT

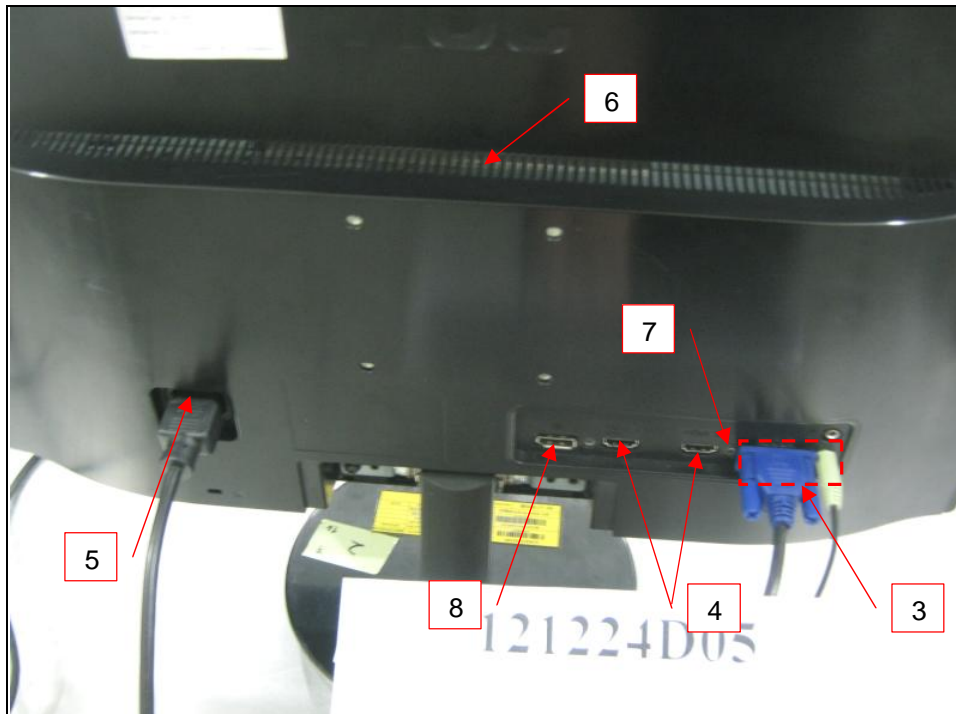

RS TEST

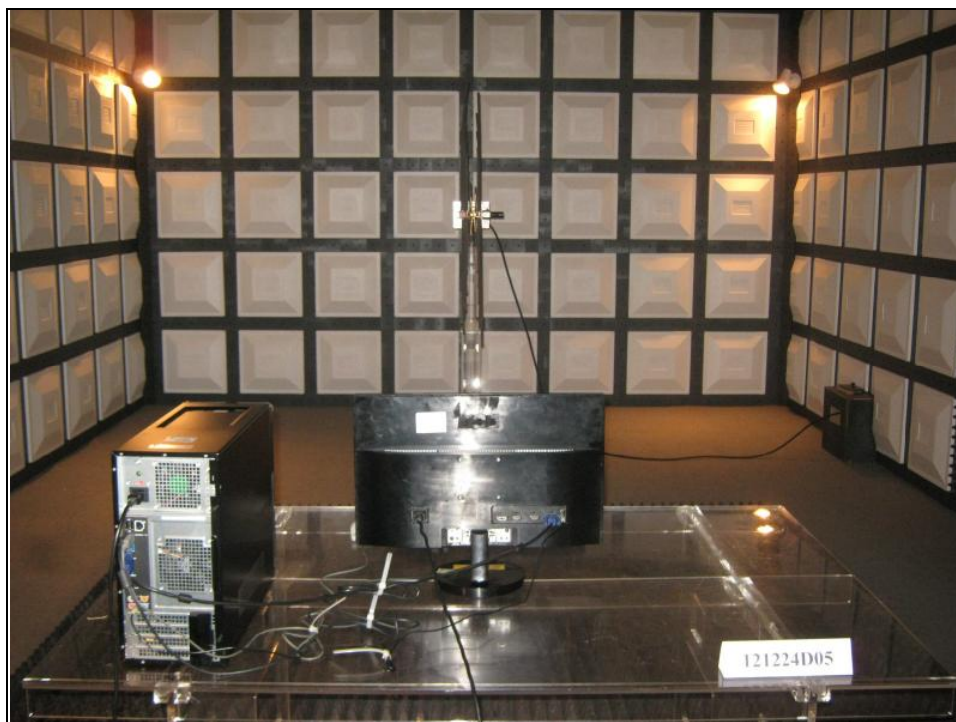

EFT TEST



SURGE TEST



CONDUCTED SUSCEPTIBILITY TEST



POWER-FREQUENCY MAGNETIC FIELDS TEST



VOLTAGE DIPS AND INTERRUPTIONS TEST





7 APPENDIX - INFORMATION ON THE TESTING LABORATORIES

We, Bureau Veritas Consumer Products Services (H.K.) Ltd., Taoyuan Branch, were founded in 1988 to provide our best service in EMC, Radio, Telecom and Safety consultation. Our laboratories are accredited and approved according to ISO/IEC 17025.

If you have any comments, please feel free to contact us at the following:

Linko EMC/RF Lab:

Tel: 886-2-26052180

Fax: 886-2-26051924

Hsin Chu EMC/RF Lab:

Tel: 886-3-5935343

Fax: 886-3-5935342

Hwa Ya EMC/RF/Safety/Telecom Lab:

Tel: 886-3-3183232

Fax: 886-3-3270892

Email: service.adt@tw.bureauveritas.com

Web Site: www.bureauveritas-adt.com

The address and road map of all our labs can be found in our web site also.

---END---