

FCC& ISED EMC Test Report

Project No. : 1904C060
Equipment : LCD Monitor
Test Model : 24B2
Series Model : **24B2*****(*=0-9,A-Z,a-z,+,-,/,\ or blank)
Applicant : TPV Electronics (Fujian) Co., Ltd.
Address : Rongqiao Economic and Technological Development Zone, Fuqing City, Fujian Province, P.R. China

Date of Receipt : Apr. 15, 2019
Date of Test : Apr. 16, 2019 ~ Apr. 20, 2019
Issued Date : May 13, 2019
Tested by : BTL Inc.

Testing Engineer : Jason Yang
(Jason Yang)

Technical Manager : Bill Zhang
(Bill Zhang)

Authorized Signatory : Kevin Li
(Kevin Li)

B T L I N C .

No.3, Jinshagang 1st Road, Shixia, Dalang Town, Dongguan, Guangdong, China.

TEL: +86-769-8318-3000 FAX: +86-769-8319-6000



Certificate #5123.02

Declaration

BTL represents to the client that testing is done in accordance with standard procedures as applicable and that test instruments used has been calibrated with standards traceable to international standard(s) and/or national standard(s).

BTL's reports apply only to the specific samples tested under conditions. It is manufacture's responsibility to ensure that additional production units of this model are manufactured with the identical electrical and mechanical components. **BTL** shall have no liability for any declarations, inferences or generalizations drawn by the client or others from **BTL** issued reports.

The report must not be used by the client to claim product certification, approval, or endorsement by NVLAP, NIST, A2LA, or any agency of the U.S. Government.

This report is the confidential property of the client. As a mutual protection to the clients, the public and ourselves, the test report shall not be reproduced, except in full, without our written approval.

BTL's laboratory quality assurance procedures are in compliance with the **ISO/IEC 17025** requirements, and accredited by the conformity assessment authorities listed in this test report.

BTL is not responsible for the sampling stage, so the results only apply to the sample as received.

The information, data and test plan are provided by manufacturer which may affect the validity of results, so it is manufacturer's responsibility to ensure that the apparatus meets the essential requirements of applied standards and in all the possible configurations as representative of its intended use.

Limitation

For the use of the authority's logo is limited unless the Test Standard(s)/Scope(s)/Item(s) mentioned in this test report is (are) included in the conformity assessment authorities acceptance respective.

Please note that the measurement uncertainty is provided for informational purpose only and are not use in determining the Pass/Fail results.

Table of Contents	Page
REPORT ISSUED HISTORY	4
1 . GENERAL SUMMARY	5
2 . SUMMARY OF TEST RESULTS	6
2.1 TEST FACILITY	7
2.2 MEASUREMENT UNCERTAINTY	7
3 . GENERAL INFORMATION	8
3.1 GENERAL DESCRIPTION OF EUT	8
3.2 DESCRIPTION OF TEST MODES	9
3.3 EUT OPERATING CONDITIONS	10
3.4 BLOCK DIAGRAM SHOWING THE CONFIGURATION OF SYSTEM TESTED	10
3.5 DESCRIPTION OF SUPPORT UNITS	11
4 . EMC EMISSION TEST	12
4.1 CONDUCTED EMISSION MEASUREMENT	12
4.1.1 POWER LINE CONDUCTED EMISSION	12
4.1.2 MEASUREMENT INSTRUMENTS LIST	12
4.1.3 TEST PROCEDURE	13
4.1.4 DEVIATION FROM TEST STANDARD	13
4.1.5 TEST SETUP	13
4.1.6 TEST RESULTS	13
4.2 RADIATED EMISSION MEASUREMENT	20
4.2.1 LIMITS OF RADIATED EMISSION MEASUREMENT	20
4.2.2 MEASUREMENT INSTRUMENTS LIST	21
4.2.3 TEST PROCEDURE	22
4.2.4 DEVIATION FROM TEST STANDARD	22
4.2.5 TEST SETUP	23
4.2.6 TEST RESULTS-BELOW 1 GHZ	23
4.2.7 TEST RESULTS-ABOVE 1 GHZ	30
5 . EUT TEST PHOTO	37

REPORT ISSUED HISTORY

Report Version	Description	Issued Date
R00	Original Issue.	Apr. 30, 2019
R01	Changed the series model name.	May 13, 2019

1. GENERAL SUMMARY

Equipment : LCD Monitor
Brand Name : N/A
Test Model : 24B2
Series Model : **24B2*****(*=0-9,A-Z,a-z,+,-,/,\ or blank)
Applicant : TPV Electronics (Fujian) Co., Ltd.
Date of Test : Apr. 16, 2019 ~ Apr. 20, 2019
Test Sample : Engineering Sample No.: D190403878
Standard(s) : FCC Part 15, Subpart B
ICES-003 Issue 6:2016
ICES-003 Issue 6:2016 (updated April 2017)
ANSI C63.4-2014

The above equipment has been tested and found compliance with the requirement of the relative standards by BTL Inc.

The test data, data evaluation, and equipment configuration contained in our test report (Ref No. BTL-FICE-1-1904C060) were obtained utilizing the test procedures, test instruments, test sites that has been accredited by the Authority of A2LA according to the ISO/IEC 17025 quality assessment standard and technical standard(s).

2. SUMMARY OF TEST RESULTS

Test procedures according to the technical standard(s):

EMC Emission				
Standard(s)	Test Item	Limit	Judgment	Remark
FCC Part15, Subpart B ICES-003 Issue 6:2016 ICES-003 Issue 6:2016 (updated April 2017) ANSI C63.4-2014	Conducted Emission	Class B	PASS	
	Radiated emission Below 1 GHz	Class B	PASS	
	Radiated emission Above 1 GHz	Class B	PASS	NOTE(2)

NOTE:

- (1) "N/A" denotes test is not applicable to this device.
- (2) The EUT's max operating frequency is 148.5MHz which does exceed 108 MHz, so the test will be performed.

2.1 TEST FACILITY

The test facilities used to collect the test data in this report at the location of No.3, Jinshagang 1st Road, Shixia, Dalang Town, Dongguan, Guangdong, China.

BTL's Test Firm Registration Number for FCC: 357015

BTL's Designation Number for FCC: CN1240

BTL's Test Firm Registration Number for ISED: 4428B

2.2 MEASUREMENT UNCERTAINTY

Where relevant, the following measurement uncertainty levels have been estimated for tests performed on the EUT as specified in CISPR 16-4-2. The BTL measurement uncertainty is less than the CISPR 16-4-2 U_{CISPR} requirement.

The reported uncertainty of measurement $y \pm U$, where expanded uncertainty U is based on a standard uncertainty multiplied by a coverage factor of $k=2$, providing a level of confidence of approximately **95%**.

A. Conducted Measurement :

Test Site	Method	Measurement Frequency Range	U, (dB)
DG-C01	CISPR	150 kHz ~ 30MHz	3.16

B. Radiated emissions up to 1 GHz measurement:

Test Site	Method	Measurement Frequency Range	Ant. H / V	U, (dB)
DG-CB08 (10m)	CISPR	30MHz ~ 200MHz	V	4.54
		30MHz ~ 200MHz	H	3.98
		200MHz ~ 1,000MHz	V	3.98
		200MHz ~ 1,000MHz	H	3.76

C. Radiated emissions above 1 GHz measurement:

Test Site	Method	Measurement Frequency Range	U, (dB)
DG-CB08 (3m)	CISPR	1 ~ 6 GHz	4.02
		6 ~18 GHz	5.10

Note: Unless specifically mentioned, the uncertainty of measurement has not been taken into account to declare the compliance or non-compliance to the specification.

3. GENERAL INFORMATION

3.1 GENERAL DESCRIPTION OF EUT

Equipment	LCD Monitor
Brand Name	N/A
Test Model	24B2
Series Model	**24B2*****(*=0-9,A-Z,a-z,+,-,/,\ or blank)
Model Difference(s)	Only differ in model name due to marketing purpose
Power Source	DC Voltage supplied from AC/DC adapter. Model: ADPC1925EX
Power Rating	I/P:100-240V~, 1.3A Max 50-60Hz O/P:19V --- 1.31A
Connecting I/O Port	1* D-SUB port 1* DC port 1* HDMI port 1* Earphone port

Cable Type	Shielded Type	Ferrite Core	Length(m)	Note
D-SUB	Shielded	YES	1.8/1.5/1.2	Bonded two Ferrite Cores
HDMI	Shielded	NO	1.8/1.5/1.2	
AC Power Cord	Non-shielded	NO	1.8/1.5/1.2	1.8m is worst case Detachable (3 Pin)

Note:

1. For a more detailed features description, please refer to the manufacturer's specifications or the user's manual.
2. Power cable 1.8m, 1.5m, 1.2m length, worst case is Power cable 1.8m with D-SUB+HDMI 1.8m length testing and recording in test report.

3.2 DESCRIPTION OF TEST MODES

To investigate the maximum EMI emission characteristics generated from EUT, the test system was pre-scanning tested base on the consideration of following EUT operation mode or test configuration mode which possible have effect on EMI emission level. Each of these EUT operation mode(s) or test configuration mode(s) mentioned above was evaluated respectively.

Pretest Mode	Description
Mode 1	D-SUB 1920*1080/60Hz
Mode 2	HDMI 1920*1080/60Hz
Mode 3	HDMI 1080P
Mode 4	HDMI 1280*1024/60Hz
Mode 5	HDMI 640*480/60Hz

For Conducted Test	
Final Test Mode	Description
Mode 1	D-SUB 1920*1080/60Hz
Mode 2	HDMI 1920*1080/60Hz
Mode 3	HDMI 1080P

For Radiated Test	
Final Test Mode	Description
Mode 1	D-SUB 1920*1080/60Hz
Mode 2	HDMI 1920*1080/60Hz
Mode 3	HDMI 1080P

Evaluation description:

1. The maximum resolution is evaluated Mode 1-3. The worst case is Mode 2 and evaluated the middle and low resolution Mode 4 and mode 5.
2. According to the client's requirement, choose Mode 1, Mode 2, Mode 3 and recorded in test report.

3.3 EUT OPERATING CONDITIONS

The EUT exercise program used during radiated and/or conducted emission measurement was designed to exercise the various system components in a manner similar to a typical use. The standard test signals and output signal as following:

1. EUT connected to PC via D-SUB & HDMI cable.
2. PC connected to Mouse and Keyboard via USB cable.
3. EUT connected to Earphone via Earphone cable.
4. PC connected to Printer via Parallel cable.
5. PC connected to Modem via RS232 cable.

3.4 BLOCK DIAGRAM SHOWING THE CONFIGURATION OF SYSTEM TESTED

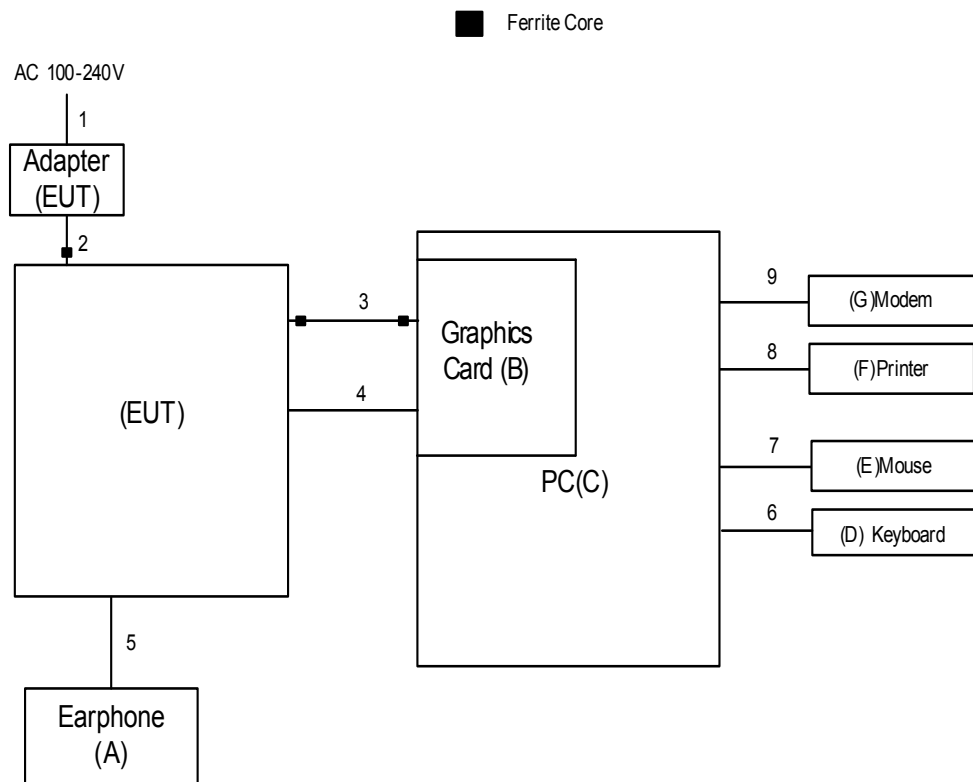

3.5 DESCRIPTION OF SUPPORT UNITS

Item	Equipment	Mfr/Brand	Model/Type No.	Series No.
A	Earphone	Apple	N/A	N/A
B	Graphics Card	DELL	ATI 3650	260832000932
C	PC	DELL	Vostro 470	28747261333
D	Keyboard	DELL	KB212-B	CN0HTXH97158125004DXA01
E	Mouse	DELL	MS111-P	CN011D3V71581279OLOT
F	Printer	SII	DPU-414	3018507 B
G	Modem	ACEEX	DM-1414V	0603002131

Item	Shielded Type	Ferrite Core	Length	Note
1	NO	NO	1.8m/1.5m/1.2m	AC Cable
2	NO	YES	1m	DC Cable
3	YES	YES	1.8m/1.5m/1.2m	D-SUB Cable
4	YES	NO	1.8m/1.5m/1.2m	HDMI Cable
5	NO	NO	1.5m	Earphone Cable
6	YES	NO	1.8m	USB Cable
7	YES	NO	1.8m	USB Cable
8	YES	NO	1.8m	Parallel Cable
9	YES	NO	1.8m	RS232 Cable

4. EMC EMISSION TEST

4.1 CONDUCTED EMISSION MEASUREMENT

4.1.1 POWER LINE CONDUCTED EMISSION (FREQUENCY RANGE 150KHZ-30MHZ)

FREQUENCY (MHz)	Class A (dBuV)		Class B (dBuV)	
	Quasi-peak	Average	Quasi-peak	Average
0.15 - 0.5	79.00	66.00	66 - 56 *	56 - 46 *
0.5 - 5.0	73.00	60.00	56.00	46.00
5.0 - 30.0	73.00	60.00	60.00	50.00

Note:

- (1) The tighter limit applies at the band edges.
- (2) The limit of " * " marked band means the limitation decreases linearly with the logarithm of the frequency in the range.
- (3) The test result calculated as following:
 Measurement Value = Reading Level + Correct Factor
 Correct Factor = Insertion Loss + Cable Loss + Attenuator Factor(if use)
 Margin Level = Measurement Value - Limit Value

4.1.2 MEASUREMENT INSTRUMENTS LIST

Item	Kind of Equipment	Manufacturer	Type No.	Serial No.	Calibrated until
1	LISN	EMCO	3816/2SH	52766	Mar. 10, 2022
2	50Ω Terminator	SHX	TF2-3G-A	8122901	Mar. 10, 2020
3	TWO-LINE V-NETWORK	R&S	ENV216	100526	Mar. 10, 2020
4	EMI Test Receiver	R&S	ESR3	101862	Aug. 11, 2019
5	Cable	N/A	N/A(6m)	N/A	Mar. 12, 2020
6	Measurement Software	Farad	EZ-EMC Ver.NB-03A 1-01	N/A	N/A

Remark: "N/A" denotes no model no., serial no. or calibration specified.
 All calibration period of equipment list is one year.

4.1.3 TEST PROCEDURE

- a. The EUT was placed 0.8 meters from the horizontal ground plane with EUT being connected to the power mains through a line impedance stabilization network (LISN). All other support equipments powered from additional LISN(s). The LISN provide 50 Ohm/ 50uH of coupling impedance for the measuring instrument.
- b. Interconnecting cables that hang closer than 40 cm to the ground plane shall be folded back and forth in the center forming a bundle 30 to 40 cm long.
- c. I/O cables that are not connected to a peripheral shall be bundled in the center. The end of the cable may be terminated, if required, using the correct terminating impedance. The overall length shall not exceed 1 m.
- d. LISN at least 80 cm from nearest part of EUT chassis.
- e. For the actual test configuration, please refer to the related Item –EUT Test Photos.
- f. First the whole spectrum of emission caused by equipment under test(EUT) is recorded with Detector set to peak. Peak value recorded in table if the margin from QP Limit is larger than 2dB, otherwise, QP value is recorded, Measuring frequency range from 150KHz to 30MHz.

4.1.4 DEVIATION FROM TEST STANDARD

No deviation

4.1.5 TEST SETUP

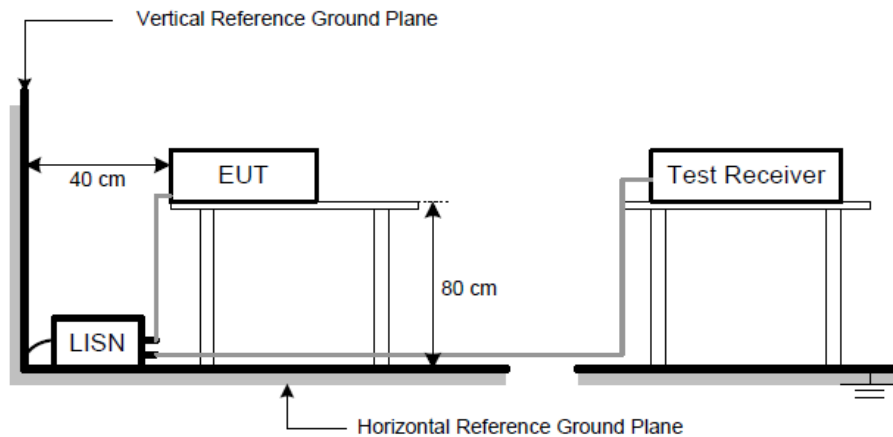

4.1.6 TEST RESULTS

Remark

- (1) Reading in which marked as QP means measurements by using are Quasi-Peak Mode with Detector BW=9 kHz; SPA setting in RBW=10 kHz, VBW =10 kHz, Swp. Time = 0.3 sec./MHz. Reading in which marked as AV means measurements by using are Average Mode with instrument setting in RBW=10 kHz, VBW=10 kHz, Swp. Time =0.3 sec./MHz.
- (2) All readings are QP Mode value unless otherwise stated AVG in column of 『Note』. If the QP Mode Measured value compliance with the QP Limits and lower than AVG Limits, the EUT shall be deemed to meet both QP & AVG Limits and then only QP Mode was measured, but AVG Mode didn't perform. In this case, a “ * ” marked in AVG Mode column of Interference Voltage Measured.

EUT	LCD Monitor	Model Name	24B2
Temperature	25°C	Relative Humidity	53%
Test Voltage	AC 120V/60Hz	Phase	Line
Test Mode	D-SUB 1920*1080/60Hz		
Test Engineer	Jason Yang		

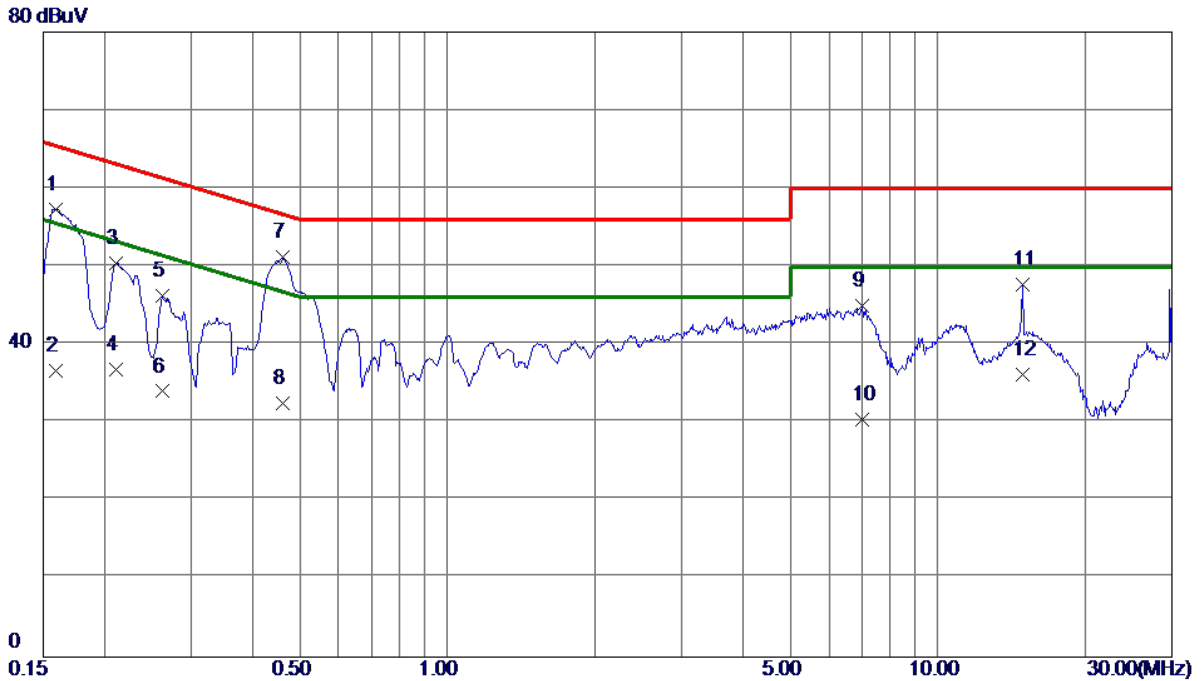

No.	Freq. MHz	Reading Level dBuV	Correct Factor dB	Measure ment dBuV	Limit dBuV	Margin dB	Detector
1	0.1590	47.52	9.81	57.33	65.52	-8.19	QP
2	0.1590	26.77	9.81	36.58	55.52	-18.94	AVG
3	0.2108	40.65	9.80	50.45	63.17	-12.72	QP
4	0.2108	26.98	9.80	36.78	53.17	-16.39	AVG
5	0.2625	36.38	9.82	46.20	61.35	-15.15	QP
6	0.2625	24.18	9.82	34.00	51.35	-17.35	AVG
7 *	0.4627	41.39	9.86	51.25	56.64	-5.39	QP
8	0.4627	22.64	9.86	32.50	46.64	-14.14	AVG
9	7.0238	34.63	10.29	44.92	60.00	-15.08	QP
10	7.0238	20.15	10.29	30.44	50.00	-19.56	AVG
11	14.8493	37.05	10.69	47.74	60.00	-12.26	QP
12	14.8493	25.47	10.69	36.16	50.00	-13.84	AVG

EUT	LCD Monitor	Model Name	24B2
Temperature	25°C	Relative Humidity	53%
Test Voltage	AC 120V/60Hz	Phase	Neutral
Test Mode	D-SUB 1920*1080/60Hz		
Test Engineer	Jason Yang		

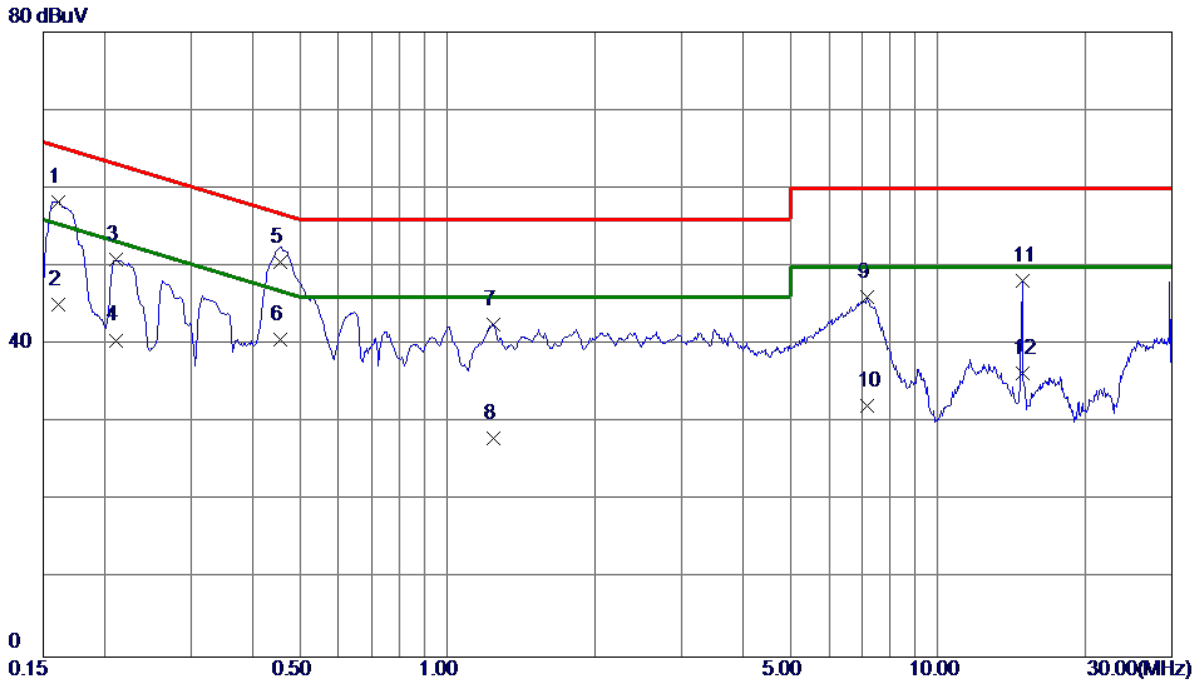

No.	Freq. MHz	Reading Level dBuV	Correct Factor dB	Measure ment dBuV	Limit dBuV	Margin dB	Detector
1	0.1613	48.37	9.90	58.27	65.40	-7.13	QP
2	0.1613	35.18	9.90	45.08	55.40	-10.32	AVG
3	0.2108	40.92	9.90	50.82	63.17	-12.35	QP
4	0.2108	30.66	9.90	40.56	53.17	-12.61	AVG
5	0.4560	40.49	10.00	50.49	56.77	-6.28	QP
6 *	0.4560	30.69	10.00	40.69	46.77	-6.08	AVG
7	1.2435	32.50	10.12	42.62	56.00	-13.38	QP
8	1.2435	17.87	10.12	27.99	46.00	-18.01	AVG
9	7.1565	35.47	10.56	46.03	60.00	-13.97	QP
10	7.1565	21.53	10.56	32.09	50.00	-17.91	AVG
11	14.8493	37.11	11.03	48.14	60.00	-11.86	QP
12	14.8493	25.24	11.03	36.27	50.00	-13.73	AVG

EUT	LCD Monitor	Model Name	24B2
Temperature	25°C	Relative Humidity	53%
Test Voltage	AC 120V/60Hz	Phase	Line
Test Mode	HDMI 1920*1080/60Hz		
Test Engineer	Jason Yang		

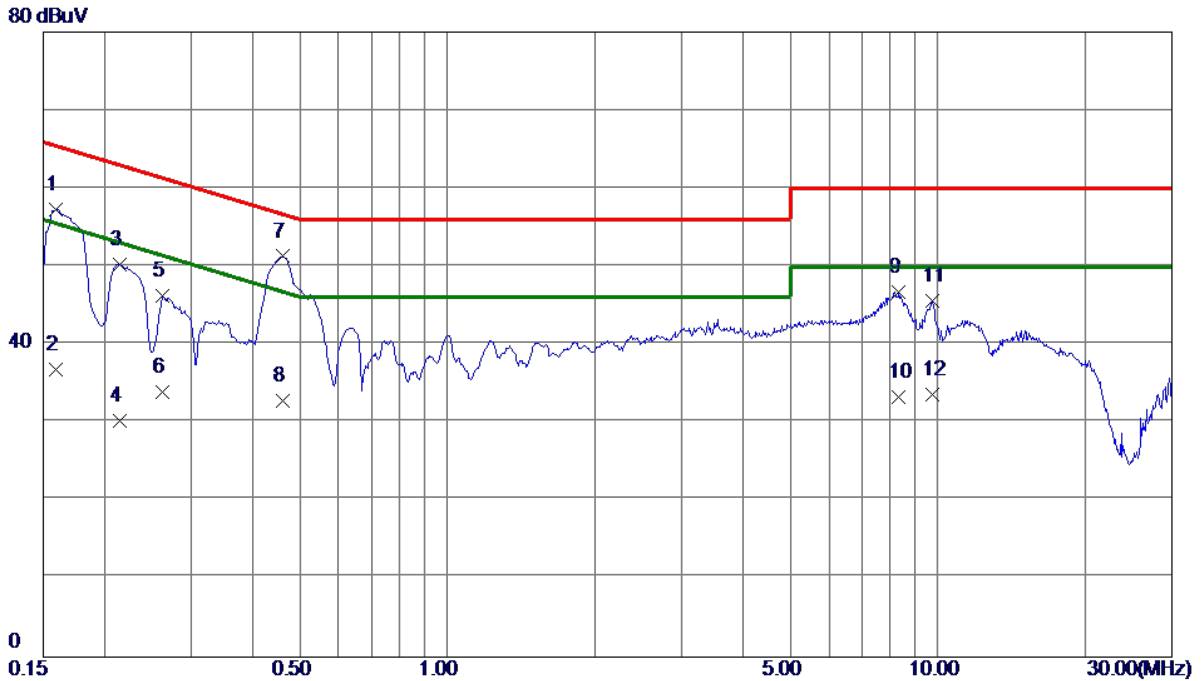

No.	Freq. MHz	Reading Level dBuV	Correct Factor dB	Measure ment dBuV	Limit dBuV	Margin dB	Detector
1	0.1590	47.49	9.81	57.30	65.52	-8.22	QP
2	0.1590	26.95	9.81	36.76	55.52	-18.76	AVG
3	0.2153	40.45	9.80	50.25	63.00	-12.75	QP
4	0.2153	20.48	9.80	30.28	53.00	-22.72	AVG
5	0.2625	36.35	9.82	46.17	61.35	-15.18	QP
6	0.2625	24.15	9.82	33.97	51.35	-17.38	AVG
7 *	0.4627	41.42	9.86	51.28	56.64	-5.36	QP
8	0.4627	22.87	9.86	32.73	46.64	-13.91	AVG
9	8.3243	36.39	10.36	46.75	60.00	-13.25	QP
10	8.3243	22.98	10.36	33.34	50.00	-16.66	AVG
11	9.7193	35.09	10.44	45.53	60.00	-14.47	QP
12	9.7193	23.15	10.44	33.59	50.00	-16.41	AVG

EUT	LCD Monitor	Model Name	24B2
Temperature	25°C	Relative Humidity	53%
Test Voltage	AC 120V/60Hz	Phase	Neutral
Test Mode	HDMI 1920*1080/60Hz		
Test Engineer	Jason Yang		

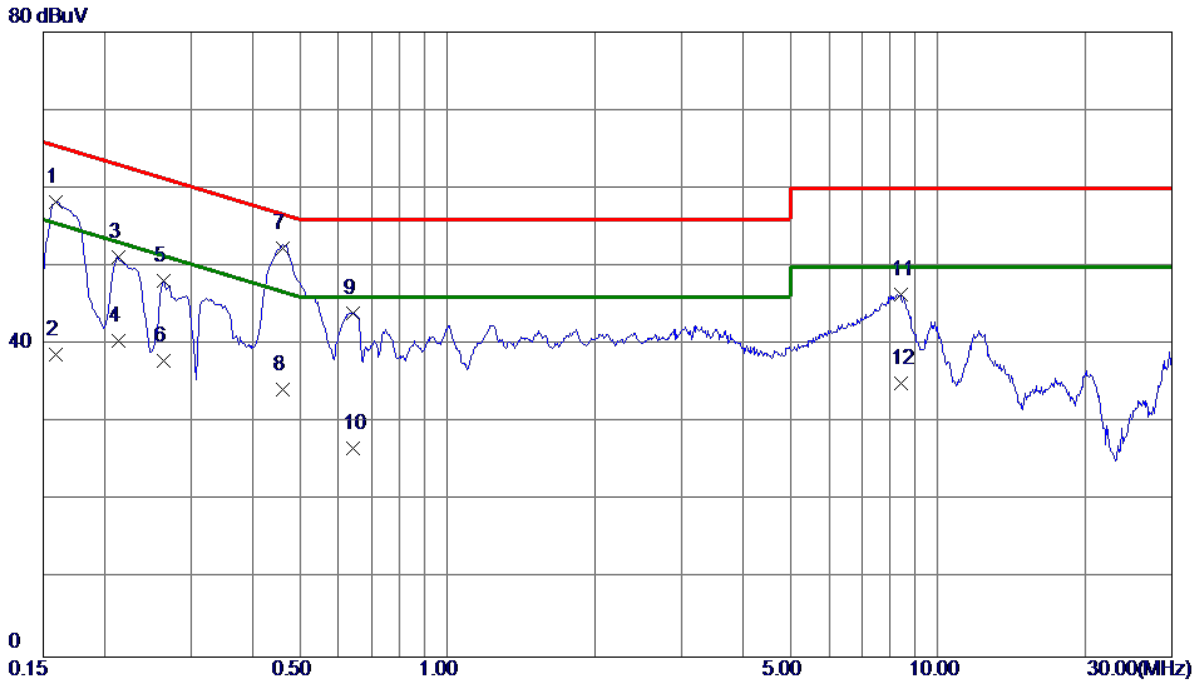

No.	Freq. MHz	Reading Level dBuV	Correct Factor dB	Measure ment dBuV	Limit dBuV	Margin dB	Detector
1	0.1590	48.34	9.90	58.24	65.52	-7.28	QP
2	0.1590	28.78	9.90	38.68	55.52	-16.84	AVG
3	0.2130	41.33	9.90	51.23	63.09	-11.86	QP
4	0.2130	30.56	9.90	40.46	53.09	-12.63	AVG
5	0.2647	38.18	9.92	48.10	61.28	-13.18	QP
6	0.2647	27.98	9.92	37.90	51.28	-13.38	AVG
7 *	0.4627	42.37	10.00	52.37	56.64	-4.27	QP
8	0.4627	24.19	10.00	34.19	46.64	-12.45	AVG
9	0.6427	34.03	10.03	44.06	56.00	-11.94	QP
10	0.6427	16.68	10.03	26.71	46.00	-19.29	AVG
11	8.4075	35.82	10.63	46.45	60.00	-13.55	QP
12	8.4075	24.44	10.63	35.07	50.00	-14.93	AVG

EUT	LCD Monitor	Model Name	24B2
Temperature	25°C	Relative Humidity	53%
Test Voltage	AC 120V/60Hz	Phase	Line
Test Mode	HDMI 1080P		
Test Engineer	Jason Yang		

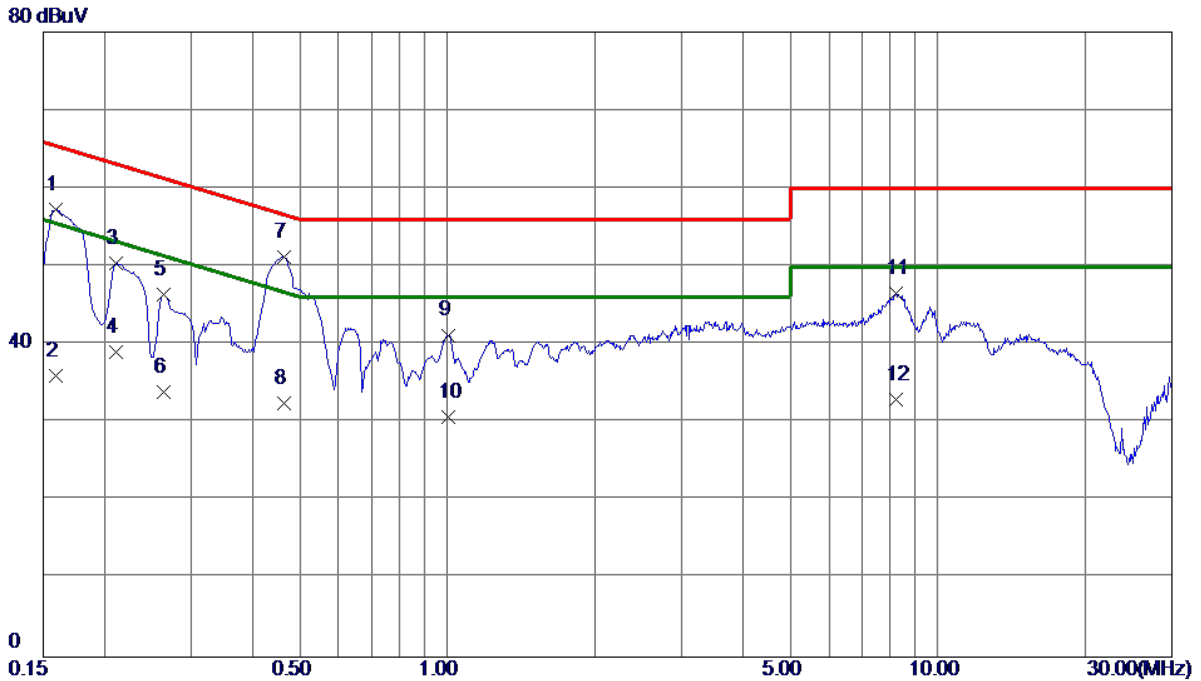

No.	Freq. MHz	Reading Level dBuV	Correct Factor dB	Measure ment dBuV	Limit dBuV	Margin dB	Detector
1	0.1590	47.45	9.81	57.26	65.52	-8.26	QP
2	0.1590	26.17	9.81	35.98	55.52	-19.54	AVG
3	0.2108	40.59	9.80	50.39	63.17	-12.78	QP
4	0.2108	29.18	9.80	38.98	53.17	-14.19	AVG
5	0.2647	36.53	9.82	46.35	61.28	-14.93	QP
6	0.2647	24.15	9.82	33.97	51.28	-17.31	AVG
7 *	0.4650	41.33	9.86	51.19	56.60	-5.41	QP
8	0.4650	22.63	9.86	32.49	46.60	-14.11	AVG
9	1.0027	31.30	9.90	41.20	56.00	-14.80	QP
10	1.0027	20.79	9.90	30.69	46.00	-15.31	AVG
11	8.2140	36.23	10.36	46.59	60.00	-13.41	QP
12	8.2140	22.61	10.36	32.97	50.00	-17.03	AVG

EUT	LCD Monitor	Model Name	24B2
Temperature	25°C	Relative Humidity	53%
Test Voltage	AC 120V/60Hz	Phase	Neutral
Test Mode	HDMI 1080P		
Test Engineer	Jason Yang		

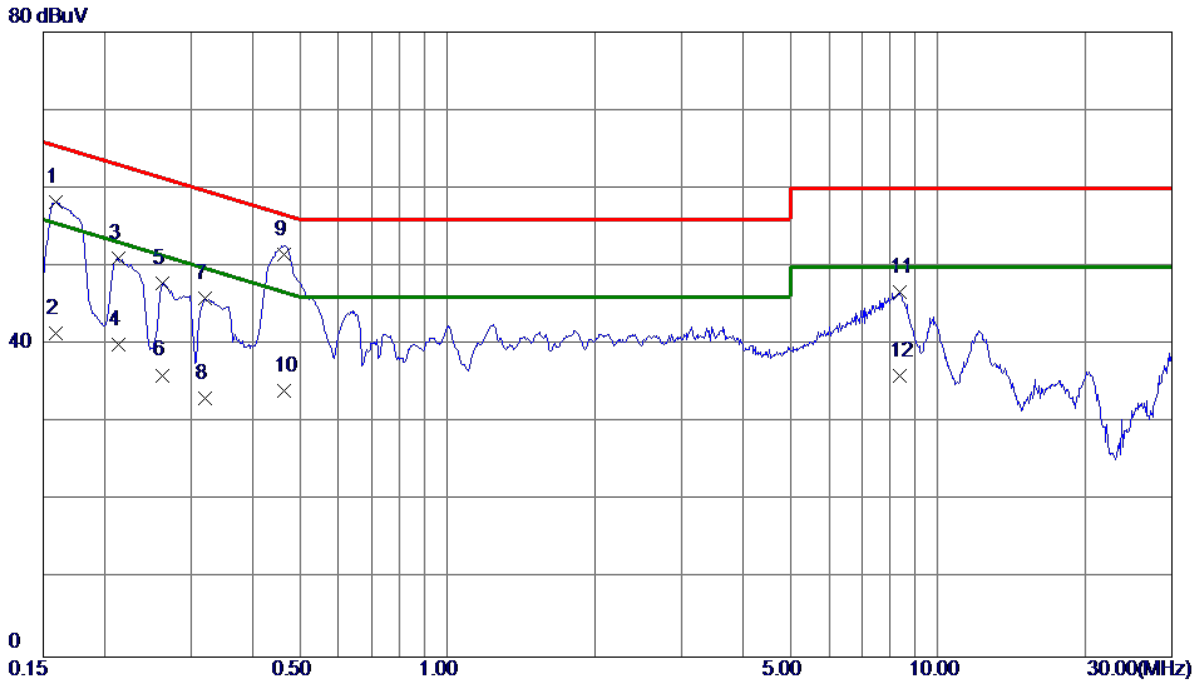

No.	Freq. MHz	Reading Level dBuV	Correct Factor dB	Measure ment dBuV	Limit dBuV	Margin dB	Detector
1	0.1590	48.33	9.90	58.23	65.52	-7.29	QP
2	0.1590	31.50	9.90	41.40	55.52	-14.12	AVG
3	0.2130	41.21	9.90	51.11	63.09	-11.98	QP
4	0.2130	30.15	9.90	40.05	53.09	-13.04	AVG
5	0.2630	37.91	9.92	47.83	61.34	-13.51	QP
6	0.2630	26.16	9.92	36.08	51.34	-15.26	AVG
7	0.3209	35.96	9.95	45.91	59.68	-13.77	QP
8	0.3209	23.15	9.95	33.10	49.68	-16.58	AVG
9 *	0.4650	41.46	10.00	51.46	56.60	-5.14	QP
10	0.4650	24.08	10.00	34.08	46.60	-12.52	AVG
11	8.3558	36.06	10.62	46.68	60.00	-13.32	QP
12	8.3558	25.36	10.62	35.98	50.00	-14.02	AVG

4.2 RADIATED EMISSION MEASUREMENT

4.2.1 LIMITS OF RADIATED EMISSION MEASUREMENT

Below 1 GHz

Measurement Method and Applied Limits:

ANSI C63.4:

Frequency (MHz)	Class A (at 10m)		Class B (at 3m)	
	(uV/m) Field strength	(dBuV/m) Field strength	(uV/m) Field strength	(dBuV/m) Field strength
30 - 88	90	39	100	40
88 - 216	150	43.5	150	43.5
216 - 960	210	46.4	200	46
Above 960	300	49.5	500	54

Above 1 GHz

Measurement Method and Applied Limits:

ANSI C63.4:

Frequency (MHz)	Class A				Class B	
	(dBuV/m) (at 3m)		(dBuV/m) (at 10m)		(dBuV/m) (at 3m)	
	Peak	Average	Peak	Average	Peak	Average
Above 1000	80	60	69.5	49.5	74	54

FREQUENCY RANGE OF RADIATED MEASUREMENT (FOR UNINTENTIONAL RADIATORS)

Highest frequency generated or Upper frequency of measurement used in the device or on which the device operates or tunes (MHz)	Range (MHz)
Below 1.705	30
1.705 - 108	1000
108 - 500	2000
500 - 1000	5000
Above 1000	5 th harmonic of the highest frequency or 40 GHz, whichever is lower

NOTE:

- (1) The limit for radiated test was performed according to as following:
FCC Part 15, Subpart B; ICES-003 Issue 6 :2016 (updated April 2017).
- (2) The tighter limit applies at the band edges.
- (3) Emission level (dBuV/m) = 20log Emission level (uV/m).
3m Emission level = 10m Emission level + 20log(10m/3m).
- (4) The test result calculated as following:
Measurement Value = Reading Level + Correct Factor
Correct Factor = Antenna Factor + Cable Loss - Amplifier Gain(if use)
Margin Level = Measurement Value - Limit Value

4.2.2 MEASUREMENT INSTRUMENTS LIST

Below 1GHz:

Item	Kind of Equipment	Manufacturer	Type No.	Serial No.	Calibrated until
1	Receiver	Keysight	N9038A	MY54450004	Aug. 11, 2019
2	MXE EMI Receiver	Agilent	N9038A	MY53220133	Mar. 10, 2020
3	Pre-Amplifier	EMC INSTRUMENT	EMC 9135	980284	Mar. 10, 2020
4	Pre-Amplifier	EMC INSTRUMENT	EMC 9135	980283	Mar. 10, 2020
5	Trilog-Broadband Antenna	Schwarzbeck	VULB9168	946	Nov. 24, 2019
6	Trilog-Broadband Antenna	Schwarzbeck	VULB9168	947	Nov. 24, 2019
7	Cable	emci	LMR-400(5m+11m+15m)	N/A	Aug. 07, 2019
8	Cable	emci	LMR-400(5m+8m+8m)	N/A	Aug. 07, 2019
9	Measurement Software	Farad	EZ-EMC Ver.BTL-2ANT-1	N/A	N/A
10	Multi-Device Controller	ETS-Lindgren	2090	N/A	N/A
11	Attenuator	EMCI	EMCI-N-6-06	N0670	Nov. 24, 2019
12	Attenuator	EMCI	EMCI-N-6-06	N0671	Nov. 24, 2019

Above 1GHz:

Item	Kind of Equipment	Manufacturer	Type No.	Serial No.	Calibrated until
1	Horn Antenna	EMCO	3115	9605-4803	Mar. 23, 2020
2	Amplifier	Agilent	8449B	3008A02584	Aug. 11, 2019
3	MXE EMI Receiver	Agilent	N9038A	MY53220133	Mar. 10, 2020
4	Measurement Software	Farad	EZ-EMC Ver.BTL-2ANT-1	N/A	N/A
5	Multi-Device Controller	ETS-Lindgren	2090	N/A	N/A
6	Controller	MF	MF-7802	MF780208159	N/A
7	Cable	Mlcable Inc.	B10-01-01-5 M	18047123	Mar. 01, 2020
8	Cable	Mlcable Inc.	B10-01-01-10 M	18072746	Mar. 01, 2020
9	Cable	N/A	A50-3.5M3.5 M-1.5M-AT	18041824	Mar. 01, 2020

Remark: "N/A" denotes no model no., no serial no. or no calibration specified.
All calibration period of equipment list is one year.

4.2.3 TEST PROCEDURE

- a. The measuring distance of 3 m shall be used for measurements. The EUT was placed on the top of a rotating table 0.8 meter above the ground at a 10 meter semi-anechoic chamber. The table was rotated 360 degrees to determine the position of the highest radiation.(below 1 GHz)
- b. The measuring distance of 3 m shall be used for measurements. The EUT was placed on the top of a rotating table 0.8 meter above the ground at a 10 meter semi-anechoic chamber. The table was rotated 360 degrees to determine the position of the highest radiation.(above 1 GHz)
- c. The height of the equipment or of the substitution antenna shall be 0.8 m, the height of the test antenna shall vary between 1 m to 4 m. Both horizontal and vertical polarizations of the antenna are set to make the measurement.
- d. For each suspected emission, the EUT was arranged to its worst case and then the antenna was tuned to heights find the maximum reading (used Bore sight function).
- e. The receiver system was set to peak and average detect function and specified bandwidth with maximum hold mode when the test frequency is above 1 GHz.
- f. The initial step in collecting radiated emission data is a receiver peak detector mode pre-scanning the measurement frequency range. Significant peaks are then marked and then Quasi Peak detector mode re-measured.
- g. All readings are Peak unless otherwise stated QP in column of Note. Peak denotes that the Peak reading compliance with the QP Limits and then QP Mode measurement didn't perform. (below 1GHz)
- h. All readings are Peak Mode value unless otherwise stated AVG in column of Note. If the Peak Mode Measured value compliance with the Peak Limits and lower than AVG Limits, the EUT shall be deemed to meet both Peak & AVG Limits and then only Peak Mode was measured, but AVG Mode didn't perform. (above 1 GHz)
- i. For the actual test configuration, please refer to the related Item - Block Diagram of system tested (please refer to 3.4).

4.2.4 DEVIATION FROM TEST STANDARD

No deviation

4.2.5 TEST SETUP

(A) Radiated Emission Test Set-Up Frequency Below 1 GHz

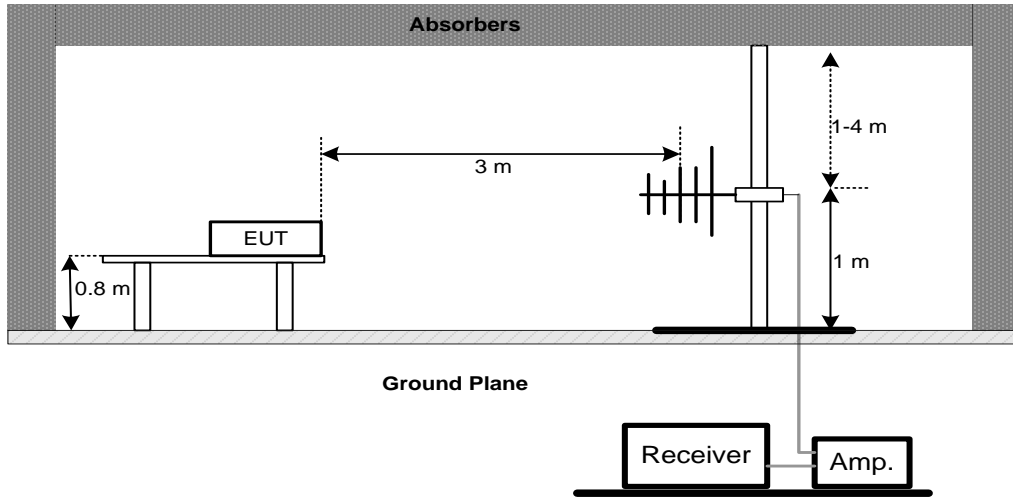

(B) Radiated Emission Test Set-Up Frequency Above 1 GHz

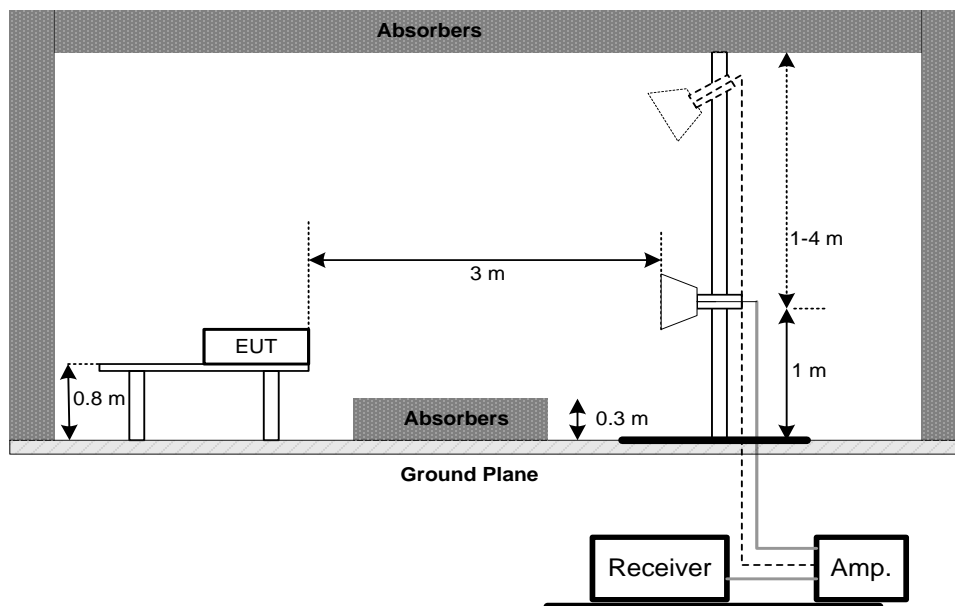

4.2.6 TEST RESULTS-BELOW 1 GHZ

Remark :

- (1) All readings are Peak unless otherwise stated QP in column of 『Note』 . Peak denotes that the Peak reading compliance with the QP Limits and then QP Mode measurement didn't perform.
- (2) Measuring frequency range from 30 MHz to 1000 MHz
- (3) If the peak scan value lower limit more than 20 dB, then this signal data does not show in table.

EUT	LCD Monitor	Model Name	24B2
Temperature	25°C	Relative Humidity	60%
Test Voltage	AC 120V/60Hz	Polarization	Vertical
Test Mode	D-SUB 1920*1080/60Hz		
Test Engineer	Jason Yang		

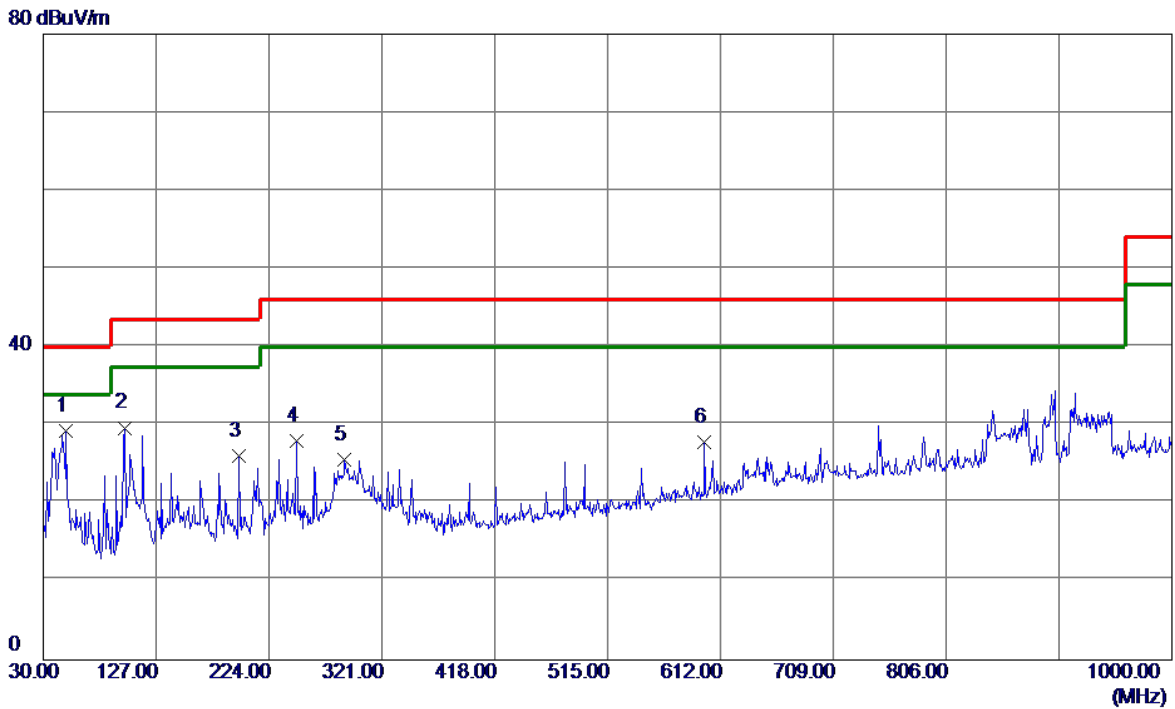

No.	Freq. MHz	Reading Level dBuV/m	Correct Factor dB	Measure ment dBuV/m	Limit dBuV/m	Margin dB	Detector
1 *	49.4000	45.91	-16.58	29.33	40.00	-10.67	QP
2	99.8399	50.66	-20.98	29.68	43.50	-13.82	QP
3	197.8100	45.02	-18.99	26.03	43.50	-17.47	QP
4	247.2800	45.11	-17.10	28.01	46.00	-17.99	QP
5	288.9900	40.97	-15.44	25.53	46.00	-20.47	QP
6	598.4200	36.28	-8.51	27.77	46.00	-18.23	QP

EUT	LCD Monitor	Model Name	24B2
Temperature	25°C	Relative Humidity	60%
Test Voltage	AC 120V/60Hz	Polarization	Horizontal
Test Mode	D-SUB 1920*1080/60Hz		
Test Engineer	Jason Yang		

80 dBuV/m

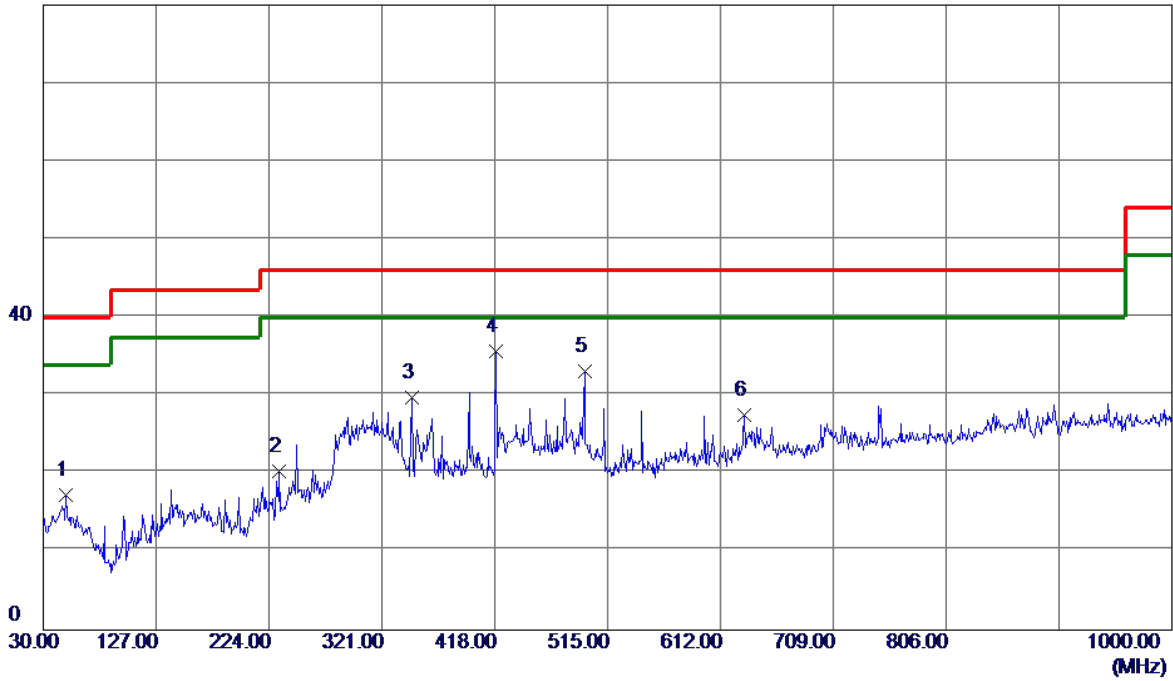

No.	Freq. MHz	Reading Level dBuV/m	Correct Factor dB	Measure ment dBuV/m	Limit dBuV/m	Margin dB	Detector
1	49.4000	33.88	-16.58	17.30	40.00	-22.70	QP
2	232.7300	38.36	-17.98	20.38	46.00	-25.62	QP
3	346.7049	43.83	-14.07	29.76	46.00	-16.24	QP
4 *	418.9700	47.94	-12.28	35.66	46.00	-10.34	QP
5	495.1150	43.72	-10.63	33.09	46.00	-12.91	QP
6	632.3700	35.40	-7.95	27.45	46.00	-18.55	QP

EUT	LCD Monitor	Model Name	24B2
Temperature	25°C	Relative Humidity	60%
Test Voltage	AC 120V/60Hz	Polarization	Vertical
Test Mode	HDMI 1920*1080/60Hz		
Test Engineer	Jason Yang		

80 dBuV/m

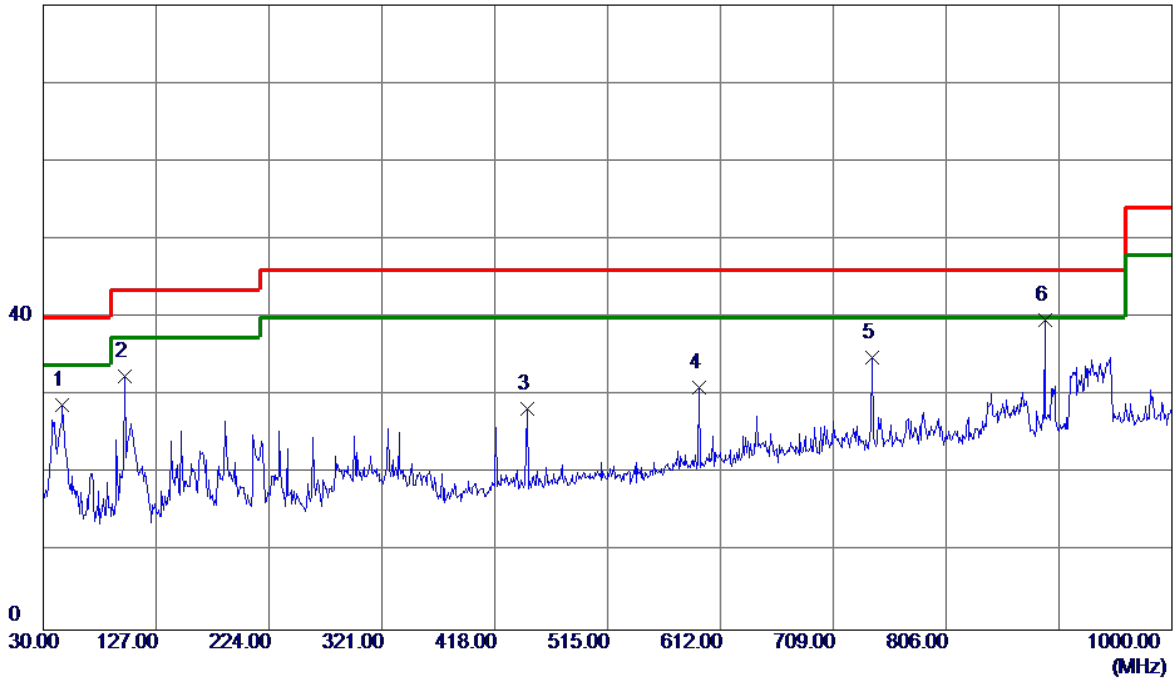

No.	Freq. MHz	Reading Level dBuV/m	Correct Factor dB	Measure ment dBuV/m	Limit dBuV/m	Margin dB	Detector
1	46.4900	45.52	-16.69	28.83	40.00	-11.17	QP
2	99.8399	53.46	-20.98	32.48	43.50	-11.02	QP
3	445.6450	39.79	-11.52	28.27	46.00	-17.73	QP
4	594.0550	39.70	-8.63	31.07	46.00	-14.93	QP
5	742.4650	41.24	-6.35	34.89	46.00	-11.11	QP
6 *	890.8750	44.28	-4.59	39.69	46.00	-6.31	QP

EUT	LCD Monitor	Model Name	24B2
Temperature	25°C	Relative Humidity	60%
Test Voltage	AC 120V/60Hz	Polarization	Horizontal
Test Mode	HDMI 1920*1080/60Hz		
Test Engineer	Jason Yang		

80 dBuV/m

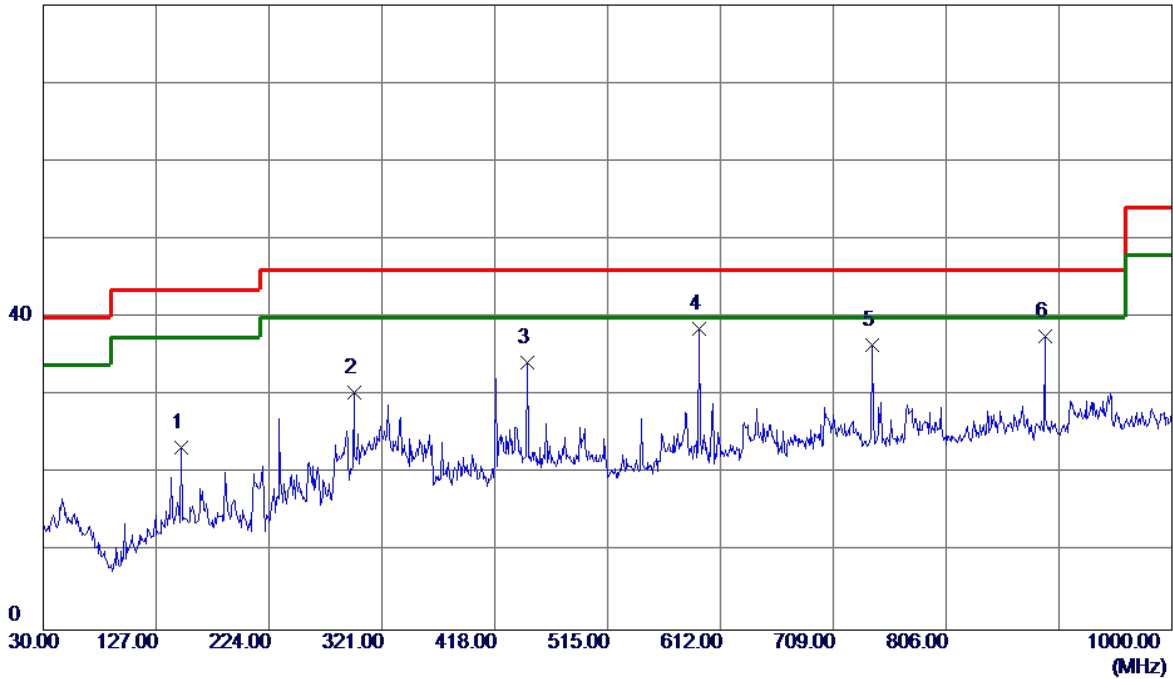

No.	Freq. MHz	Reading Level dBuV/m	Correct Factor dB	Measure ment dBuV/m	Limit dBuV/m	Margin dB	Detector
1	148.3400	39.42	-16.05	23.37	43.50	-20.13	QP
2	297.2349	45.60	-15.19	30.41	46.00	-15.59	QP
3	445.6450	45.83	-11.52	34.31	46.00	-11.69	QP
4 *	594.0550	47.25	-8.63	38.62	46.00	-7.38	QP
5	742.4650	42.84	-6.35	36.49	46.00	-9.51	QP
6	890.8750	42.14	-4.59	37.55	46.00	-8.45	QP

EUT	LCD Monitor	Model Name	24B2
Temperature	25°C	Relative Humidity	60%
Test Voltage	AC 120V/60Hz	Polarization	Vertical
Test Mode	HDMI 1080P		
Test Engineer	Jason Yang		

80 dBuV/m

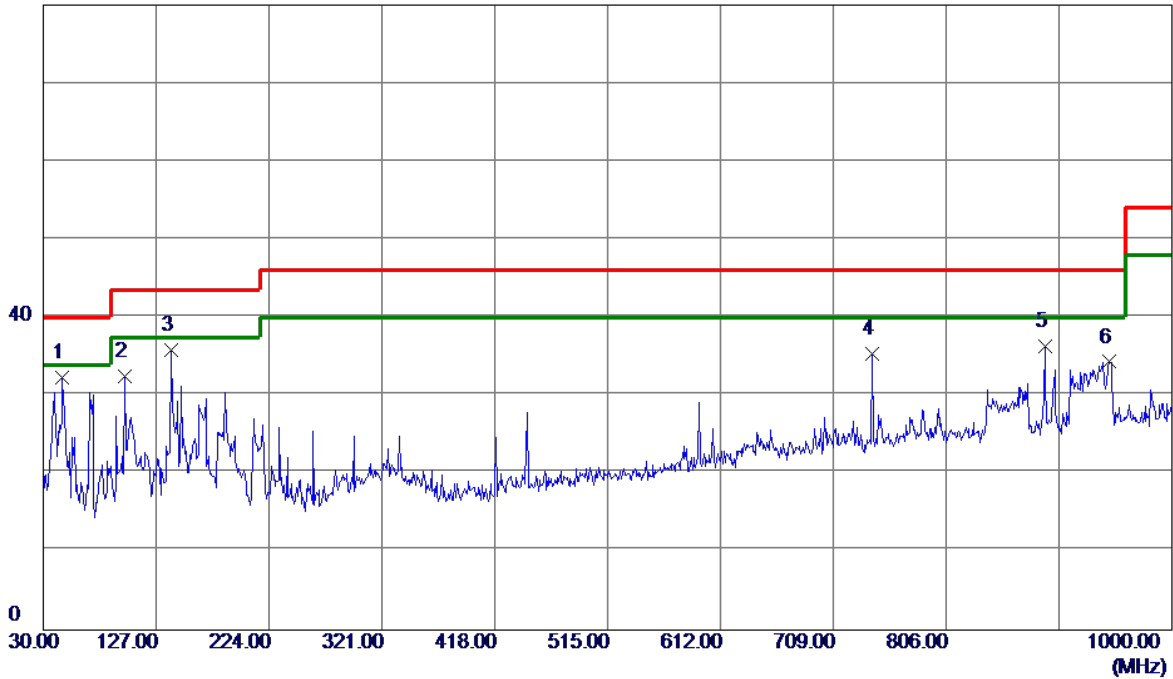

No.	Freq. MHz	Reading Level dBuV/m	Correct Factor dB	Measure ment dBuV/m	Limit dBuV/m	Margin dB	Detector
1	46.4900	48.96	-16.69	32.27	40.00	-7.73	QP
2	99.8399	53.49	-20.98	32.51	43.50	-10.99	QP
3 *	139.6100	52.40	-16.57	35.83	43.50	-7.67	QP
4	742.4650	41.68	-6.35	35.33	46.00	-10.67	QP
5	890.8750	40.90	-4.59	36.31	46.00	-9.69	QP
6	945.6800	37.88	-3.56	34.32	46.00	-11.68	QP

EUT	LCD Monitor	Model Name	24B2
Temperature	25°C	Relative Humidity	60%
Test Voltage	AC 120V/60Hz	Polarization	Horizontal
Test Mode	HDMI 1080P		
Test Engineer	Jason Yang		

80 dBuV/m

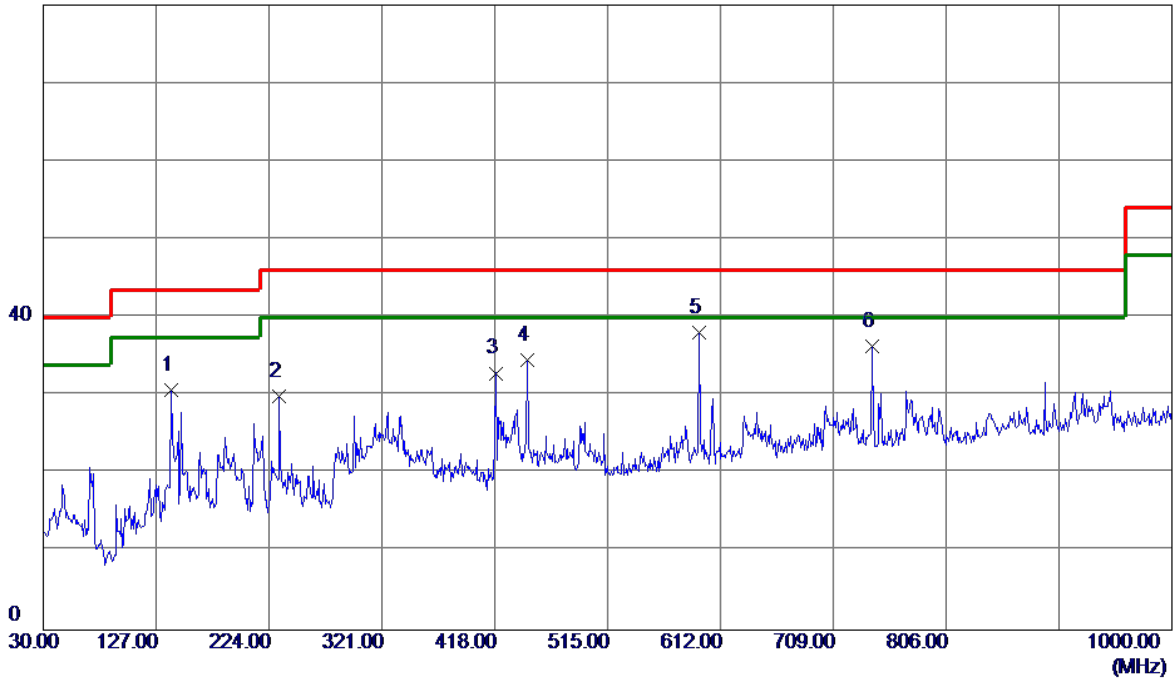

No.	Freq. MHz	Reading Level dBuV/m	Correct Factor dB	Measure ment dBuV/m	Limit dBuV/m	Margin dB	Detector
1	139.6100	47.23	-16.57	30.66	43.50	-12.84	QP
2	232.7300	47.94	-17.98	29.96	46.00	-16.04	QP
3	418.9700	45.16	-12.28	32.88	46.00	-13.12	QP
4	445.6450	46.15	-11.52	34.63	46.00	-11.37	QP
5 *	594.0550	46.74	-8.63	38.11	46.00	-7.89	QP
6	742.4650	42.70	-6.35	36.35	46.00	-9.65	QP

4.2.7 TEST RESULTS-ABOVE 1 GHZ

Remark :

- (1) All readings are Peak unless otherwise stated QP in column of 『Note 』. Peak denotes that the Peak reading compliance with the QP Limits and then QP Mode measurement didn't perform.
- (2) Radiated emissions measured in frequency range above 1000 MHz were made with an instrument using Peak detector mode and AV detector mode of the emission.
- (3) Data of measurement within this frequency range shown “ * ” in the table above means the reading of emissions are attenuated more than 20 dB below the permissible limits or the field strength is too small to be measured.
- (4) A preamp and high pass filter were used for this test in order to provide sufficient measurement sensitivity.

EUT	LCD Monitor	Model Name	24B2
Temperature	25°C	Relative Humidity	60%
Test Voltage	AC 120V/60Hz	Polarization	Vertical
Test Mode	D-SUB 1920*1080/60Hz		
Test Engineer	Jason Yang		

86.9 dBuV/m

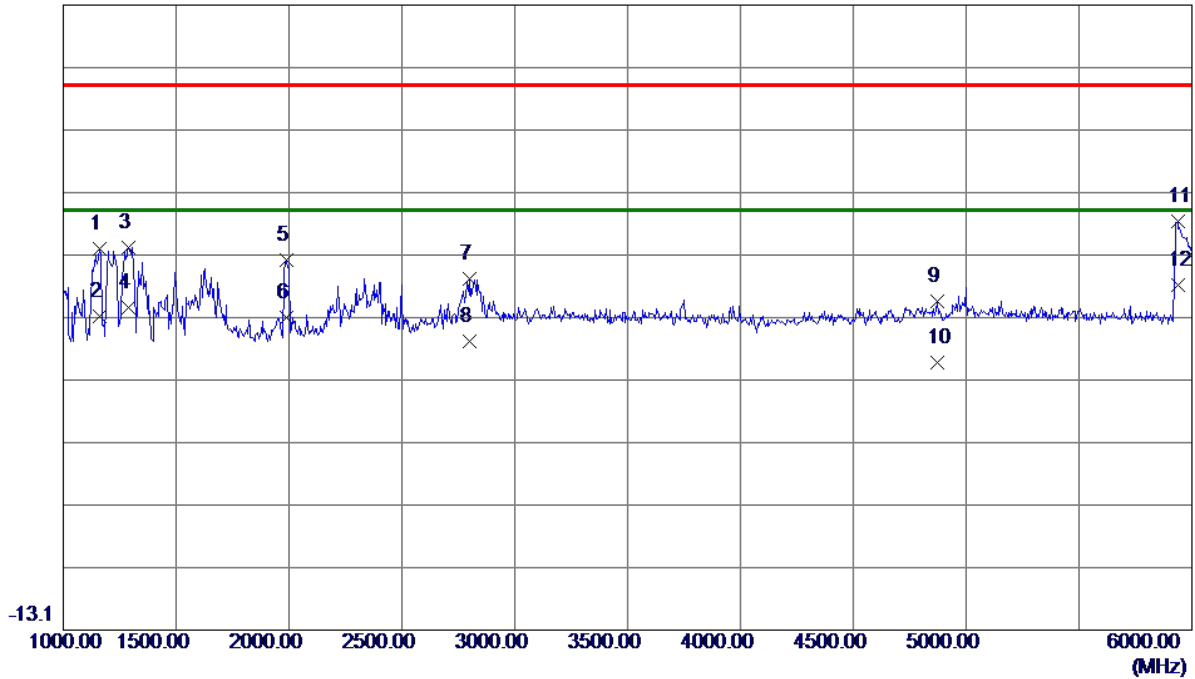

No.	Freq. MHz	Reading Level dBuV/m	Correct Factor dB	Measure ment dBuV/m	Limit dBuV/m	Margin dB	Detector
1	1162.5000	56.83	-8.89	47.94	74.00	-26.06	Peak
2	1162.5000	46.05	-8.89	37.16	54.00	-16.84	AVG
3	1290.0000	56.40	-8.32	48.08	74.00	-25.92	Peak
4	1290.0000	46.77	-8.32	38.45	54.00	-15.55	AVG
5	1990.0000	52.51	-6.32	46.19	74.00	-27.81	Peak
6	1990.0000	43.17	-6.32	36.85	54.00	-17.15	AVG
7	2800.0000	46.42	-3.30	43.12	74.00	-30.88	Peak
8	2800.0000	36.34	-3.30	33.04	54.00	-20.96	AVG
9	4872.5000	39.10	0.40	39.50	74.00	-34.50	Peak
10	4872.5000	29.25	0.40	29.65	54.00	-24.35	AVG
11	5937.5000	51.65	0.61	52.26	74.00	-21.74	Peak
12 *	5937.5000	41.54	0.61	42.15	54.00	-11.85	AVG

EUT	LCD Monitor	Model Name	24B2
Temperature	25°C	Relative Humidity	60%
Test Voltage	AC 120V/60Hz	Polarization	Horizontal
Test Mode	D-SUB 1920*1080/60Hz		
Test Engineer	Jason Yang		

86.9 dBuV/m

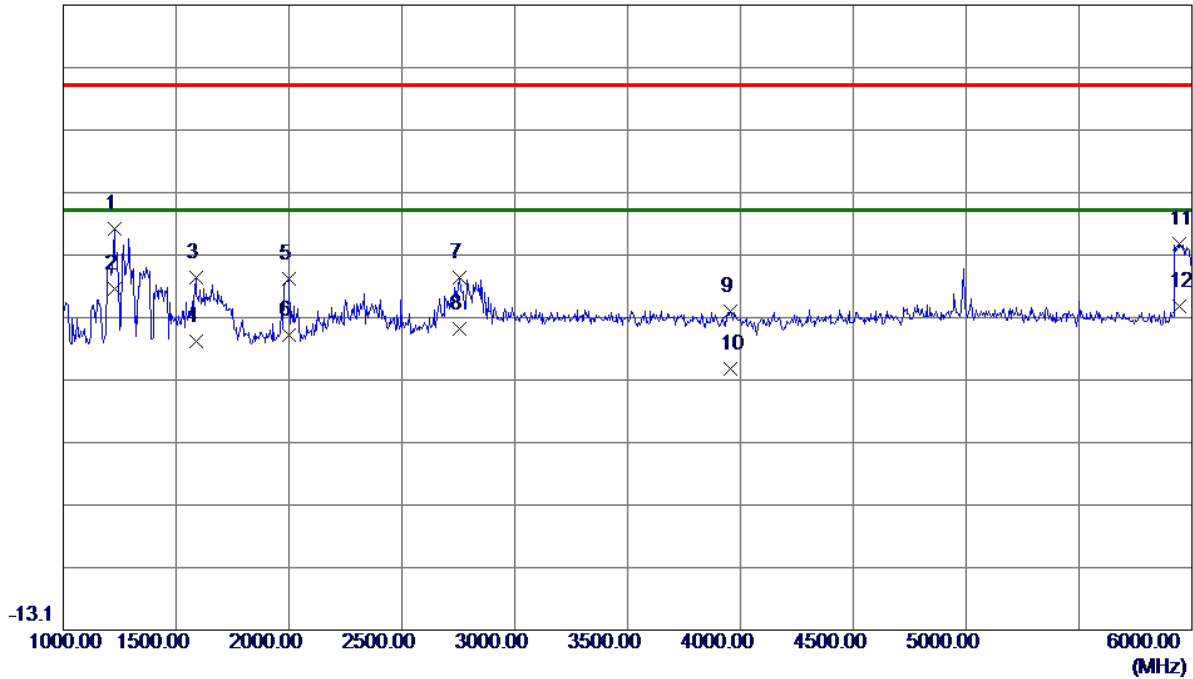

No.	Freq. MHz	Reading Level dBuV/m	Correct Factor dB	Measure ment dBuV/m	Limit dBuV/m	Margin dB	Detector
1	1227.5000	59.64	-8.60	51.04	74.00	-22.96	Peak
2 *	1227.5000	50.15	-8.60	41.55	54.00	-12.45	AVG
3	1587.5000	50.54	-7.21	43.33	74.00	-30.67	Peak
4	1587.5000	40.36	-7.21	33.15	54.00	-20.85	AVG
5	2000.0000	49.35	-6.30	43.05	74.00	-30.95	Peak
6	2000.0000	40.46	-6.30	34.16	54.00	-19.84	AVG
7	2757.5000	46.80	-3.47	43.33	74.00	-30.67	Peak
8	2757.5000	38.52	-3.47	35.05	54.00	-18.95	AVG
9	3955.0000	39.41	-1.54	37.87	74.00	-36.13	Peak
10	3955.0000	30.20	-1.54	28.66	54.00	-25.34	AVG
11	5942.5000	48.11	0.61	48.72	74.00	-25.28	Peak
12	5942.5000	38.01	0.61	38.62	54.00	-15.38	AVG

EUT	LCD Monitor	Model Name	24B2
Temperature	25°C	Relative Humidity	60%
Test Voltage	AC 120V/60Hz	Polarization	Vertical
Test Mode	HDMI 1920*1080/60Hz		
Test Engineer	Jason Yang		

86.9 dBuV/m

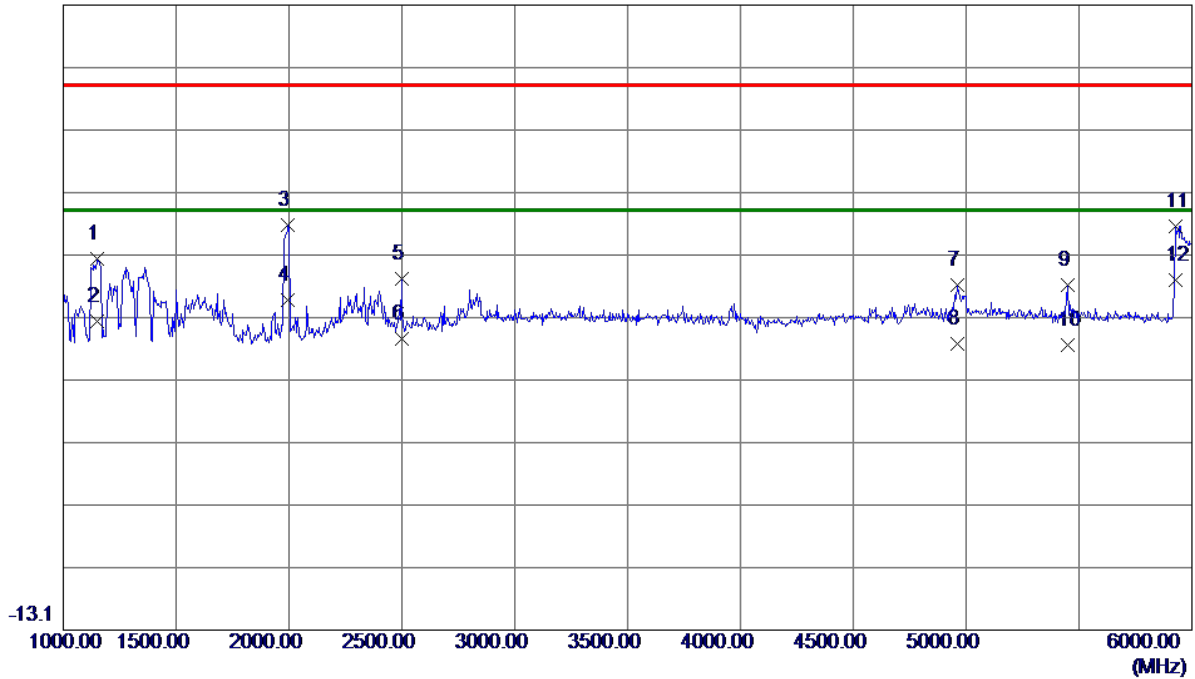

No.	Freq. MHz	Reading Level dBuV/m	Correct Factor dB	Measure ment dBuV/m	Limit dBuV/m	Margin dB	Detector
1	1147.5000	55.27	-8.95	46.32	74.00	-27.68	Peak
2	1147.5000	45.16	-8.95	36.21	54.00	-17.79	AVG
3	1995.0000	58.05	-6.31	51.74	74.00	-22.26	Peak
4	1995.0000	45.99	-6.31	39.68	54.00	-14.32	AVG
5	2497.5000	47.58	-4.51	43.07	74.00	-30.93	Peak
6	2497.5000	38.06	-4.51	33.55	54.00	-20.45	AVG
7	4962.5000	41.45	0.68	42.13	74.00	-31.87	Peak
8	4962.5000	31.97	0.68	32.65	54.00	-21.35	AVG
9	5450.0000	41.42	0.66	42.08	74.00	-31.92	Peak
10	5450.0000	31.81	0.66	32.47	54.00	-21.53	AVG
11	5930.0000	50.97	0.61	51.58	74.00	-22.42	Peak
12 *	5930.0000	42.22	0.61	42.83	54.00	-11.17	AVG

EUT	LCD Monitor	Model Name	24B2
Temperature	25°C	Relative Humidity	60%
Test Voltage	AC 120V/60Hz	Polarization	Horizontal
Test Mode	HDMI 1920*1080/60Hz		
Test Engineer	Jason Yang		

86.9 dBuV/m

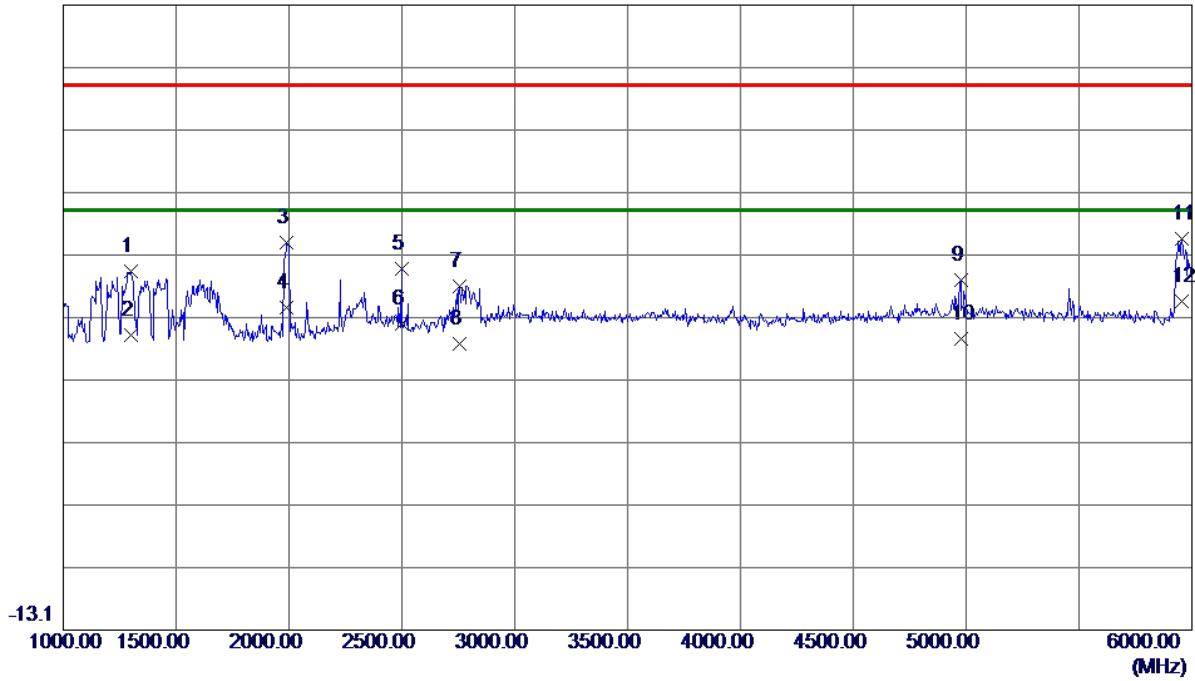

No.	Freq. MHz	Reading Level dBuV/m	Correct Factor dB	Measure ment dBuV/m	Limit dBuV/m	Margin dB	Detector
1	1302.5000	52.50	-8.27	44.23	74.00	-29.77	Peak
2	1302.5000	42.42	-8.27	34.15	54.00	-19.85	AVG
3	1990.0000	55.30	-6.32	48.98	74.00	-25.02	Peak
4	1990.0000	44.76	-6.32	38.44	54.00	-15.56	AVG
5	2497.5000	49.30	-4.51	44.79	74.00	-29.21	Peak
6	2497.5000	40.36	-4.51	35.85	54.00	-18.15	AVG
7	2757.5000	45.45	-3.47	41.98	74.00	-32.02	Peak
8	2757.5000	36.13	-3.47	32.66	54.00	-21.34	AVG
9	4977.5000	42.09	0.73	42.82	74.00	-31.18	Peak
10	4977.5000	32.72	0.73	33.45	54.00	-20.55	AVG
11	5957.5000	48.83	0.60	49.43	74.00	-24.57	Peak
12 *	5957.5000	38.96	0.60	39.56	54.00	-14.44	AVG

EUT	LCD Monitor	Model Name	24B2
Temperature	25°C	Relative Humidity	60%
Test Voltage	AC 120V/60Hz	Polarization	Vertical
Test Mode	HDMI 1080P		
Test Engineer	Jason Yang		

86.9 dBuV/m

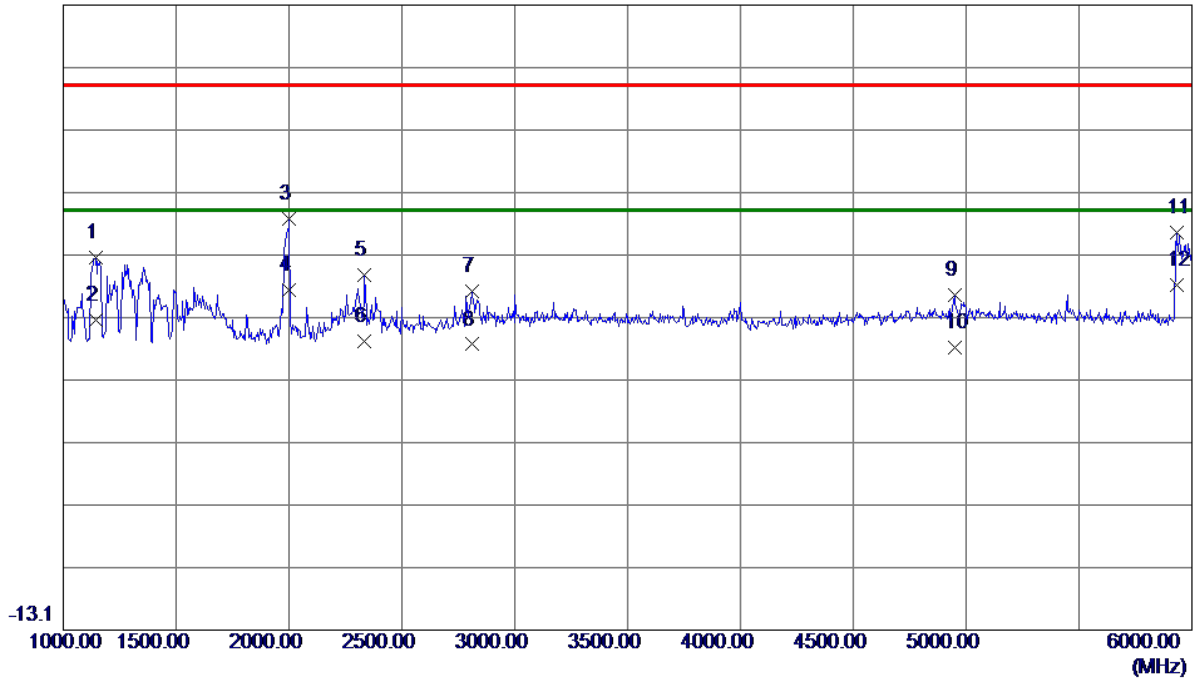

No.	Freq. MHz	Reading Level dBuV/m	Correct Factor dB	Measure ment dBuV/m	Limit dBuV/m	Margin dB	Detector
1	1142.5000	55.53	-8.97	46.56	74.00	-27.44	Peak
2	1142.5000	45.49	-8.97	36.52	54.00	-17.48	AVG
3	2000.0000	59.08	-6.30	52.78	74.00	-21.22	Peak
4	2000.0000	47.56	-6.30	41.26	54.00	-12.74	AVG
5	2335.0000	48.83	-5.09	43.74	74.00	-30.26	Peak
6	2335.0000	38.24	-5.09	33.15	54.00	-20.85	AVG
7	2810.0000	44.32	-3.26	41.06	74.00	-32.94	Peak
8	2810.0000	35.86	-3.26	32.60	54.00	-21.40	AVG
9	4947.5000	39.83	0.64	40.47	74.00	-33.53	Peak
10	4947.5000	31.41	0.64	32.05	54.00	-21.95	AVG
11	5932.5000	49.86	0.61	50.47	74.00	-23.53	Peak
12 *	5932.5000	41.54	0.61	42.15	54.00	-11.85	AVG

EUT	LCD Monitor	Model Name	24B2
Temperature	25°C	Relative Humidity	60%
Test Voltage	AC 120V/60Hz	Polarization	Horizontal
Test Mode	HDMI 1080P		
Test Engineer	Jason Yang		

86.9 dBuV/m

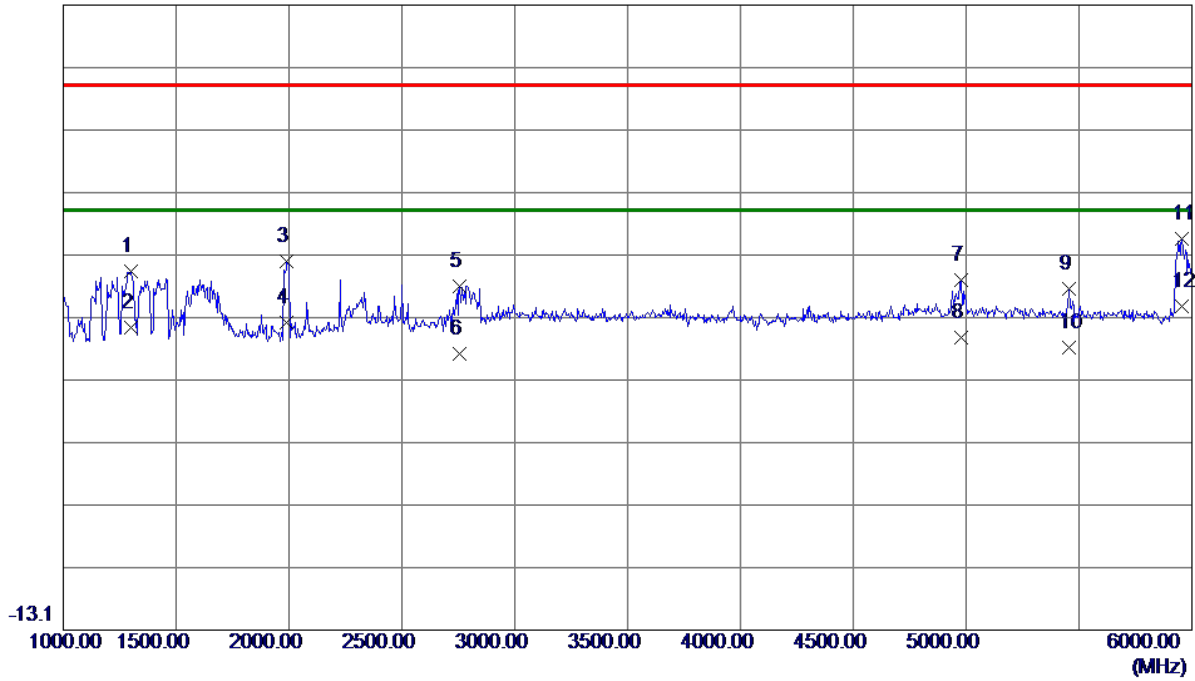

No.	Freq. MHz	Reading Level dBuV/m	Correct Factor dB	Measure ment dBuV/m	Limit dBuV/m	Margin dB	Detector
1	1302.5000	52.50	-8.27	44.23	74.00	-29.77	Peak
2	1302.5000	43.53	-8.27	35.26	54.00	-18.74	AVG
3	1990.0000	52.30	-6.32	45.98	74.00	-28.02	Peak
4	1990.0000	42.46	-6.32	36.14	54.00	-17.86	AVG
5	2757.5000	45.45	-3.47	41.98	74.00	-32.02	Peak
6	2757.5000	34.51	-3.47	31.04	54.00	-22.96	AVG
7	4977.5000	42.09	0.73	42.82	74.00	-31.18	Peak
8	4977.5000	32.93	0.73	33.66	54.00	-20.34	AVG
9	5457.5000	40.86	0.66	41.52	74.00	-32.48	Peak
10	5457.5000	31.48	0.66	32.14	54.00	-21.86	AVG
11	5957.5000	48.83	0.60	49.43	74.00	-24.57	Peak
12 *	5957.5000	38.08	0.60	38.68	54.00	-15.32	AVG

5. EUT TEST PHOTO

Conducted Emission



Radiated emission below 1 GHz

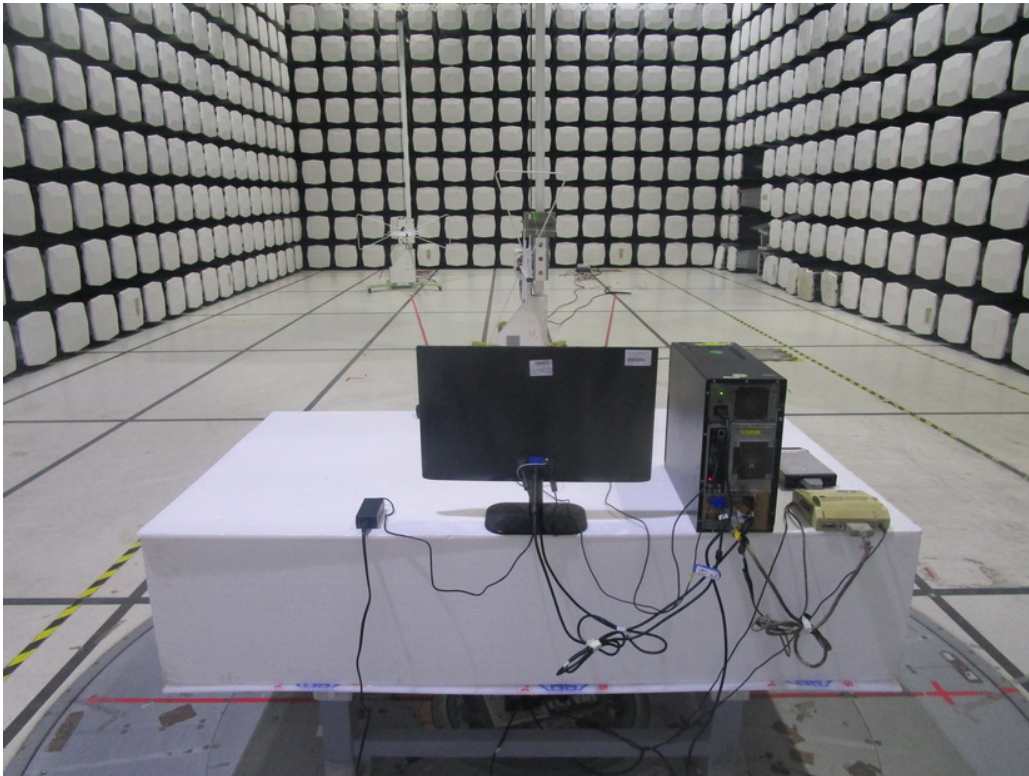
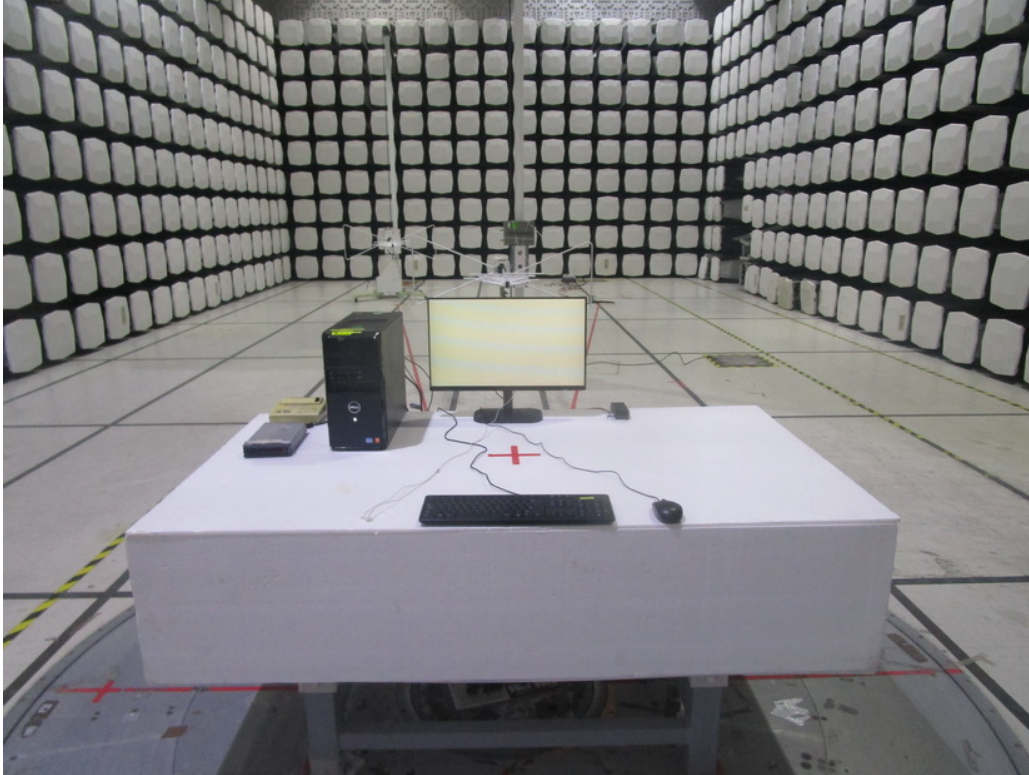

Radiated emission above 1 GHz

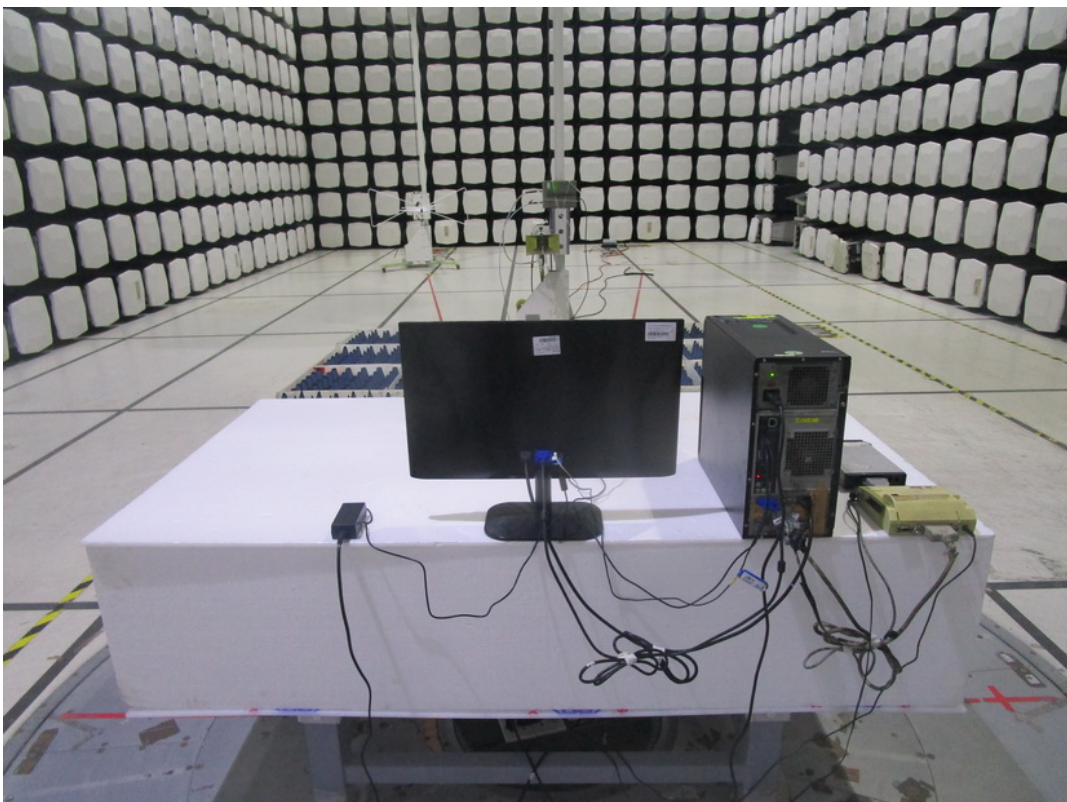
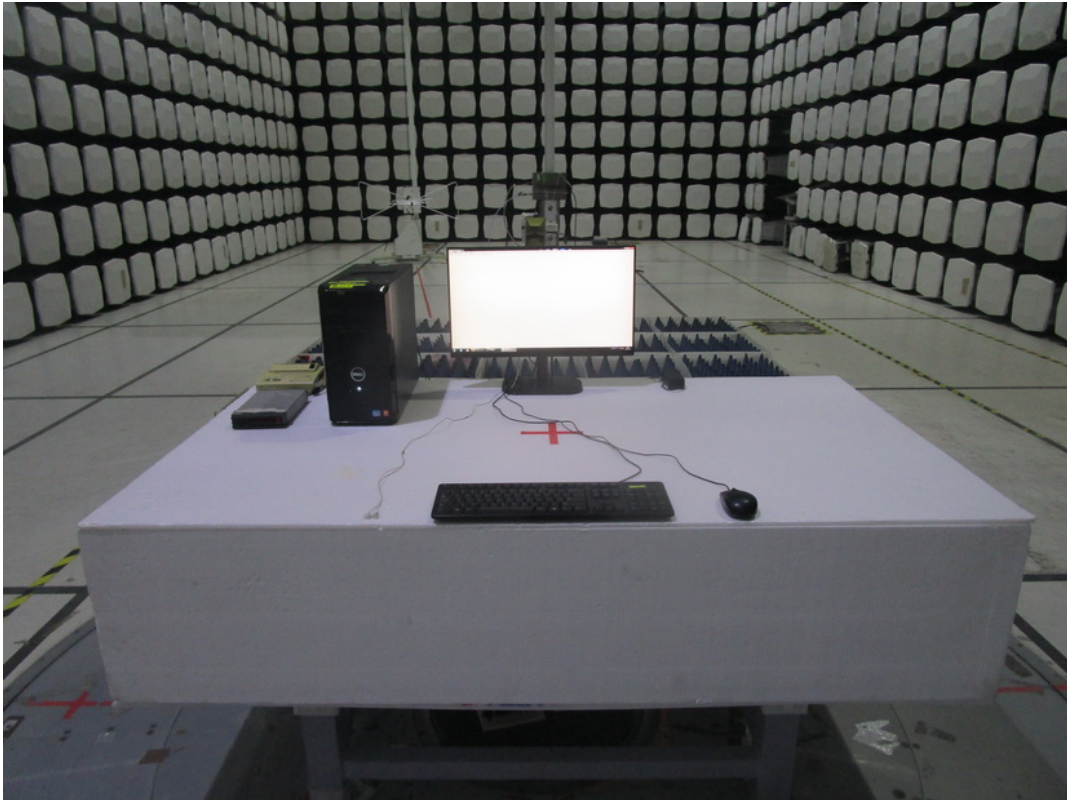

End of Test Report