



# FCC DOC TEST REPORT

Applicant : TPV Electronics (Fujian) Co., Ltd.  
Address : Rongqiao Economic and Technological  
Development Zone, Fuqing City, Fujian Province,  
P.R. China  
Equipment : LCD Monitor  
Model No. : 270LM0004, \*\*2790\*\*\*\*\*

## I HEREBY CERTIFY THAT :

The sample was received on Aug. 24, 2017 and the testing was carried out on Aug. 26, 2017 at CerpPASS Technology Corp. The test result refers exclusively to the test presented test model / sample. Without written approval of CerpPASS Technology Corp., the test report shall not be reproduced except in full.

Approved by:

Kero / EMC & RF Manager

Laboratory Accreditation:

CerpPASS Technology Corporation Test Laboratory





## Contents

|  |           |
|--|-----------|
| <b>1. Summary of Test Procedure and Test Result</b> .....  | <b>4</b>  |
| 1.1. Applicable Standards .....                            | 4         |
| <b>2. Test Configuration of Equipment under Test</b> ..... | <b>5</b>  |
| 2.1. Feature of Equipment under Test.....                  | 5         |
| 2.2. Test Manner .....                                     | 5         |
| 2.3. Description of Test System.....                       | 6         |
| 2.4. General Information of Test.....                      | 7         |
| 2.5. Measurement Uncertainty .....                         | 7         |
| <b>3. Test of Conducted Emission</b> .....                 | <b>8</b>  |
| 3.1. Test Limit .....                                      | 8         |
| 3.2. Test Procedures .....                                 | 8         |
| 3.3. Typical test Setup.....                               | 9         |
| 3.4. Measurement Equipment.....                            | 9         |
| 3.5. Test Result and Data.....                             | 10        |
| 3.6. Test Photographs .....                                | 12        |
| <b>4. Test of Radiated Emission</b> .....                  | <b>13</b> |
| 4.1. Test Limit .....                                      | 13        |
| 4.2. Test Procedures .....                                 | 13        |
| 4.3. Typical test Setup.....                               | 14        |
| 4.4. Measurement Equipment.....                            | 14        |
| 4.5. Test Result and Data (30MHz ~ 1GHz).....              | 15        |
| 4.6. Test Result and Data (1GHz ~ 18GHz).....              | 17        |
| 4.7. Test Photographs (30MHz~1GHz) .....                   | 19        |
| 4.8. Test Photographs (1GHz~18GHz) .....                   | 20        |
| <b>5. Photographs of EUT</b> .....                         | <b>21</b> |





## 1. Summary of Test Procedure and Test Result

### 1.1. Applicable Standards

#### FCC

The measurements shown in this test report were made in accordance with the procedures given in ANSI C63.4 – 2014 and the energy emitted by this equipment was passed Part 2, Part 15, CISPR PUB. 22.

#### Canada

The measurements shown in this test report were made in accordance with the procedures given in Canada ICES-003 issue 6 section 3.a and 3.b.

The energy emitted by this equipment was passed both Radiated and Conducted Emissions Class **B** limits.

| Test Item          | Normative References  | Test Result | Remarks   |
|--------------------|---|-------------|---|
| Conducted Emission | ANSI C63.4-2014,<br>FCC Part 15 Subpart B, KDB17416,<br>Canada ICES-003 issue 6 | PASS        | Meets Class B Limit<br>Minimum passing margin(QP) is<br>-14.28 dB at 0.5740 MHz |
| Radiated Emission  | ANSI C63.4-2014,<br>FCC Part 15 Subpart B, KDB17416,<br>Canada ICES-003 issue 6 | PASS        | Meets Class B Limit<br>Minimum passing margin(QP) is<br>-5.57 dB at 66.53 MHz   |



## 2. Test Configuration of Equipment under Test

### 2.1. Feature of Equipment under Test

|                                    |                            |  |
|------------------------------------|----------------------------|--|
| LCD Monitor                        | Model No.                  | 270LM0004, **2790*****<br>(The “*” could be any alphanumeric character including blank for marketing differentiation.) |
| Power Cable                        | Non-Shielding, 1.5m & 1.8m |  |
| Please refer to the user’s manual. |                            |  |

### 2.2. Test Manner

- a. During testing, the interface cables and equipment positions were varied according to ANSI C63.4.
- b. An executive program, “Burnin.exe” under WIN 7, which generates a complete line of continuously repeating “H” pattern were used as the test software.

The program was executed as follows:

1. Turn on the power of all equipment.
  2. The PC reads the test program from the hard disk drive and runs it.
  3. The PC sends “H” messages to the EUT, and the EUT displays “H” patterns on the screen.
  4. The PC sends “H” messages to the internal Hard Disk, and the Hard Disk reads and writes the message.
  5. The PC sends “H” messages to the printer, then the printer prints them on the paper.
  6. Repeat the steps from 2 to 5.
- c. An executive program, “Burnin.exe” was executed to play 1kHz audio.
  - d. An executive program, “Burnin.exe” was executed to read and write data from USB3.0 HDD.
  - e. The complete test system included PC, Keyboard, Mouse, Printer, iPod, Earphone, USB3.0 HDD, DVD Player, Notebook and EUT for EMI test.
  - f. The test modes of EMI test as follow:

- Test Mode 1. AC 120V, Display: 1920 x 1080@144Hz for Horizontal
- Test Mode 2. AC 120V, Display: 1280 x 1024@75Hz for Horizontal
- Test Mode 3. AC 120V, Display: 640 x 480@60Hz for Horizontal
- Test Mode 4. AC 120V, Display: 1920 x 1080@144Hz for Vertical
- Test Mode 5. AC 120V, VGA: 1920 x 1080@144Hz for Horizontal
- Test Mode 6. AC 120V, VGA: 1280 x 1024@75Hz for Horizontal
- Test Mode 7. AC 120V, VGA: 640 x 480@60Hz for Horizontal
- Test Mode 8. AC 120V, VGA: 1920 x 1080@144Hz for Vertical
- Test Mode 9. AC 120V, HDMI 1: 1920 x 1080@144Hz for Horizontal
- Test Mode 10. AC 120V, HDMI 1: 1280 x 1024@75Hz for Horizontal
- Test Mode 11. AC 120V, HDMI 1: 640 x 480@60Hz for Horizontal
- Test Mode 12. AC 120V, HDMI 1: 1920 x 1080@144Hz for Vertical
- Test Mode 13. AC 120V, HDMI 1: 1080P, DVD Mode for Horizontal
- Test Mode 14. AC 120V, HDMI 2: 1920 x 1080@144Hz for Horizontal
- Test Mode 15. AC 120V, HDMI 2: 1280 x 1024@75Hz for Horizontal
- Test Mode 16. AC 120V, HDMI 2: 640 x 480@60Hz for Horizontal
- Test Mode 17. AC 120V, HDMI 2: 1920 x 1080@144Hz for Vertical
- Test Mode 18. AC 120V, HDMI 2: 1080P, DVD Mode for Horizontal



Test Mode 19. AC 240V, Display: 1920 x 1080@144Hz for Horizontal

Test Mode 20. AC 240V, VGA: 1920 x 1080@144Hz for Horizontal

Test Mode 21. AC 240V, HDMI 1: 1920 x 1080@144Hz for Horizontal

Test Mode 22. AC 240V, HDMI 2: 1920 x 1080@144Hz for Horizontal

For conduction test, The “Test Mode 9” generated the worst test result, it was reported as final data.

For radiation test (below 1GHz), The “Test Mode 1” generated the worst test result, it was reported as final data.

For radiation test (above 1GHz), The “Test Mode 14” generated the worst test result, it was reported as final data.

- g. The maximum operating frequency is above 108MHz, the test frequency range is from 30MHz to 18GHz.

### 2.3. Description of Test System

| Device       | Manufacturer | Model No.    | Description   |
|--------------|--------------|--------------|---|
| PC           | DELL         | XPS8700      | Power Cable, Non-Shielded, 1.8m                           |
| Keyboard     | DELL         | SK-8175      | USB Cable, Shielding 1.85m                                |
| Mouse        | DELL         | MS111-P      | USB Cable, Shielding 1.85m                                |
| Printer      | HP           | P1102w       | Power Cable, Non-Shielded 1m<br>USB Cable, Shielding 1.6m |
| iPod         | APPLE        | A1320        | USB Cable, Shielding 1m                                   |
| Earphone     | APPLE        | EarPods      | Audio Cable, Unshielding 1.35m                            |
| USB3.0 HDD*4 | WD           | WD1600BEVT/P | USB3.0 Cable, Shielding 0.5m                              |
| DVD player   | SONY         | DVP-NS718HP  | Power Cable, Unshielding, 1.8m                            |

Use Cable:

| Cable      | Quantity | Description       |
|------------|----------|-------------------|
| HDMI       | 2        | Shielding, 1.8m   |
| HDMI       | 2        | Shielding, 1.5m   |
| DP         | 1        | Shielding, 1.8m   |
| DP         | 1        | Shielding, 1.5m   |
| VGA        | 1        | Shielding, 1.8m   |
| VGA        | 1        | Shielding, 1.5m   |
| Audio      | 1        | Unshielding, 1.8m |
| USB A to B | 1        | Shielding, 1.8m   |



## 2.4. General Information of Test

|                               |  |
|-------------------------------|--|
| Test Site                     | <b>Cerpass Technology Corporation Test Laboratory</b><br>Address: No.10, Ln. 2, Lianfu St., Luzhu Dist., Taoyuan City 33848, Taiwan (R.O.C.)<br>Tel:+886-3-3226-888<br>Fax:+886-3-3226-881<br>Address: No.68-1, Shihbachongsi, Shihding Township, New Taipei City 223, Taiwan, R.O.C.<br>Tel: +886-2-2663-8582 |
| FCC                           | TW1079, TW1061, 390316, 228391, 641184   |
| IC                            | 4934E-1, 4934E-2   |
| VCCI                          | T-2205 for Telecommunication Test<br>C-4663 for Conducted emission test<br>R-4399, R-4218 for Radiated emission test<br>G-812, G-813 for radiated disturbance above 1GHz   |
| Frequency Range Investigated: | Conducted: from 150kHz to 30 MHz<br>Radiation: from 30 MHz to 18000MHz   |
| Test Distance :               | The test distance of radiated emission below 1GHz from antenna to EUT is 10 M.<br>The test distance of radiated emission above 1GHz from antenna to EUT is 3 M.  |

## 2.5. Measurement Uncertainty

| Measurement Item   | Measurement Frequency  | Polarization          | Uncertainty |
|--------------------|------------------------|-----------------------|-------------|
| Conducted Emission | 9 kHz ~ 30 MHz         | LINE / NEUTRAL        | ± 3.25 dB   |
| Radiated Emission  | 30 MHz ~ 1,000 MHz     | Vertical / Horizontal | ± 3.93 dB   |
|                    | 1,000 MHz ~ 6,000 MHz  | Vertical / Horizontal | ± 4.01 dB   |
|                    | 6,000 MHz ~ 18,000 MHz | Vertical / Horizontal | ± 4.72 dB   |

The measurement uncertainty will be considered, when test result margin to the limit.



### 3. Test of Conducted Emission

#### 3.1. Test Limit

Conducted Emissions were measured from 150 kHz to 30 MHz with a bandwidth of 9 KHz, according to the methods defined in ANSI C63.4-2014. The EUT was placed on a nonmetallic stand in a shielded room 0.8 meters above the ground plane. The interface cables and equipment positioning were varied within limits of reasonable applications to determine the position produced maximum conducted emissions.

#### Conducted Emission Limits:

| Frequency (MHz) | Quasi Peak (dB $\mu$ V) | Average (dB $\mu$ V) |
|-----------------|-------------------------|----------------------|
| 0.15 – 0.5      | 66-56*                  | 56-46*               |
| 0.5 – 5.0       | 56                      | 46                   |
| 5.0 – 30.0      | 60                      | 50                   |

#### 3.2. Test Procedures

- a. The EUT was placed 0.4 meter from the conducting wall of the shielding room was kept at least 80 centimeters from any other grounded conducting surface.
- b. Connect EUT to the power mains through a line impedance stabilization network (LISN).
- c. All the support units are connecting to the other LISN.
- d. The LISN provides 50 ohm coupling impedance for the measuring instrument.
- e. The FCC states that a 50 ohm, 50 micro-Henry LISN should be used.
- f. Both sides of AC line were checked for maximum conducted interference.
- g. The frequency range from 150 kHz to 30 MHz was searched.
- h. Set the test-receiver system to Peak Detect Function and Specified Bandwidth with Maximum Hold Mode.



### 3.3. Typical test Setup

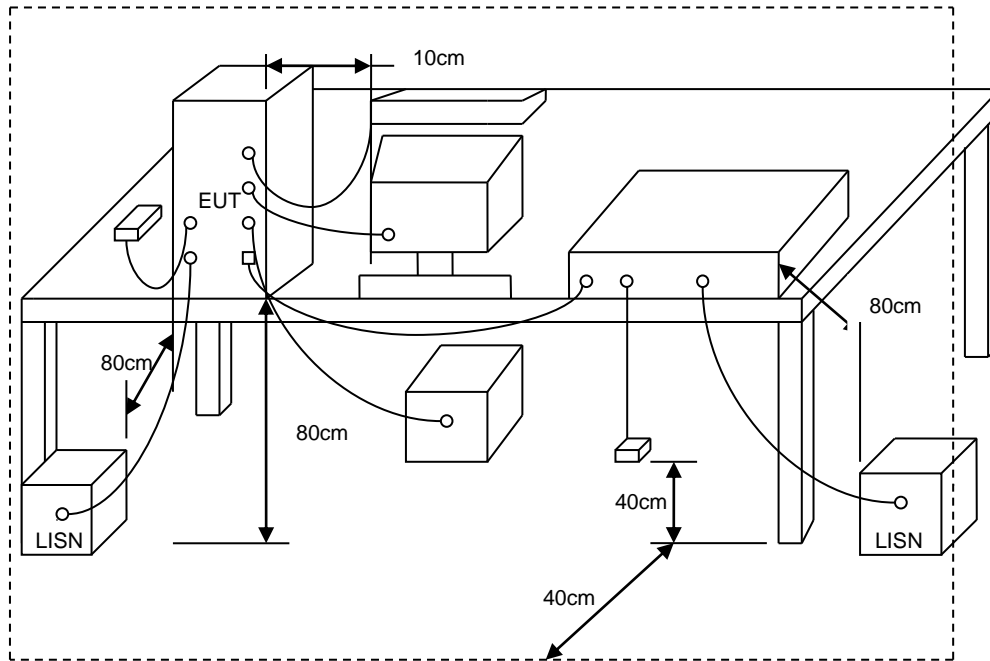

### 3.4. Measurement Equipment

| Instrument    | Manufacturer | Model No. | Serial No. | Calibration Date | Valid Date |
|---------------|--------------|-----------|------------|------------------|------------|
| EMI Receiver  | R&S          | ESCI3     | 100443     | 2017/03/07       | 2018/03/06 |
| LISN          | Schwarzbeck  | NSLK 8127 | 8127-568   | 2017/02/15       | 2018/02/14 |
| LISN          | Schwarzbeck  | NSLK 8127 | 8127-740   | 2016/08/30       | 2017/08/29 |
| Pulse Limiter | R&S          | ESH3-Z2   | 101934     | 2017/02/14       | 2018/02/13 |
| Software      | Farad        | Ez-EMC    | ver.ct3a1  | N/A              | N/A        |



### 3.5. Test Result and Data

|           |                 |             |         |
|-----------|-----------------|-------------|---------|
| Power     | : AC 120V       | Pol/Phase   | : LINE  |
| Test Mode | : Mode 9        | Temperature | : 23 °C |
| Test Date | : Aug. 24, 2017 | Humidity    | : 45 %  |
| Model No. | : 270LM00048    |             |         |

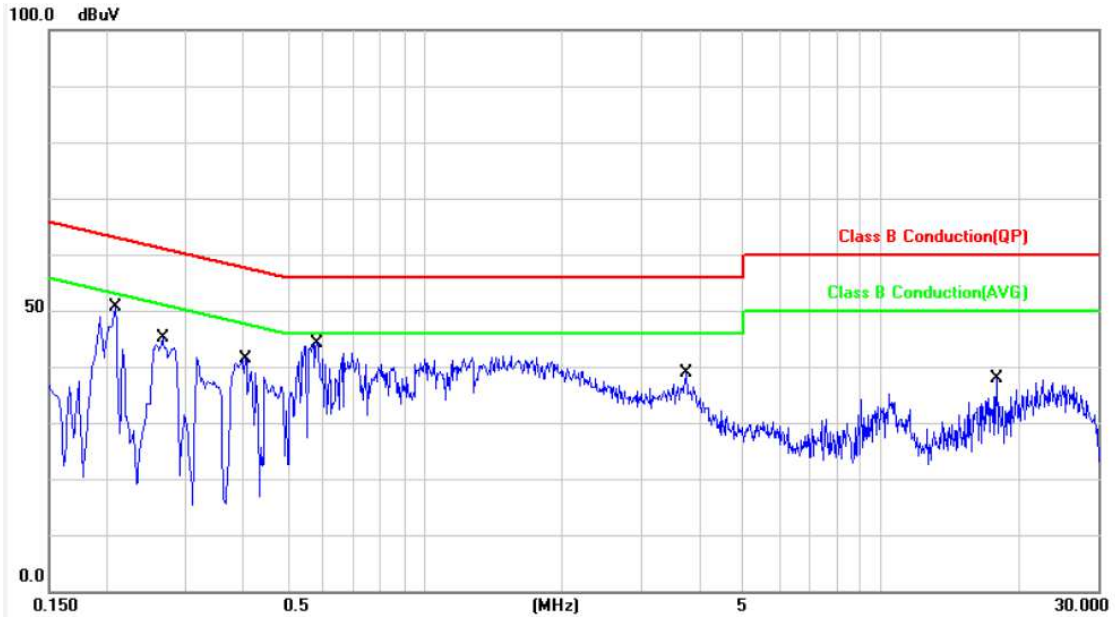

| No. | Frequency (MHz) | Factor (dB) | Reading (dBuV) | Level (dBuV) | Limit (dBuV) | Margin (dB) | Detector | P/F |
|-----|-----------------|-------------|----------------|--------------|--------------|-------------|----------|-----|
| 1   | 0.2100          | 9.91        | 37.10          | 47.01        | 63.20        | -16.19      | QP       | P   |
| 2   | 0.2100          | 9.91        | 23.63          | 33.54        | 53.20        | -19.66      | AVG      | P   |
| 3   | 0.2660          | 9.91        | 34.57          | 44.48        | 61.24        | -16.76      | QP       | P   |
| 4   | 0.2660          | 9.91        | 23.32          | 33.23        | 51.24        | -18.01      | AVG      | P   |
| 5   | 0.4060          | 9.93        | 28.84          | 38.77        | 57.73        | -18.96      | QP       | P   |
| 6   | 0.4060          | 9.93        | 16.00          | 25.93        | 47.73        | -21.80      | AVG      | P   |
| 7   | 0.5820          | 9.94        | 31.43          | 41.37        | 56.00        | -14.63      | QP       | P   |
| 8   | 0.5820          | 9.94        | 16.24          | 26.18        | 46.00        | -19.82      | AVG      | P   |
| 9   | 3.7540          | 10.12       | 20.88          | 31.00        | 56.00        | -25.00      | QP       | P   |
| 10  | 3.7540          | 10.12       | 13.28          | 23.40        | 46.00        | -22.60      | AVG      | P   |
| 11  | 18.0140         | 10.56       | 24.23          | 34.79        | 60.00        | -25.21      | QP       | P   |
| 12  | 18.0140         | 10.56       | 22.30          | 32.86        | 50.00        | -17.14      | AVG      | P   |

Note: Level = Reading + Factor  
 Margin = Level – Limit  
 Factor = (LISN, ISN, PLC or current probe) Factor + Cable Loss+ Attenuator



|           |                 |             |           |
|-----------|-----------------|-------------|-----------|
| Power     | : AC 120V       | Pol/Phase   | : NEUTRAL |
| Test Mode | : Mode 9        | Temperature | : 23 °C   |
| Test Date | : Aug. 24, 2017 | Humidity    | : 45 %    |
| Model No. | : 270LM00048    |             |           |

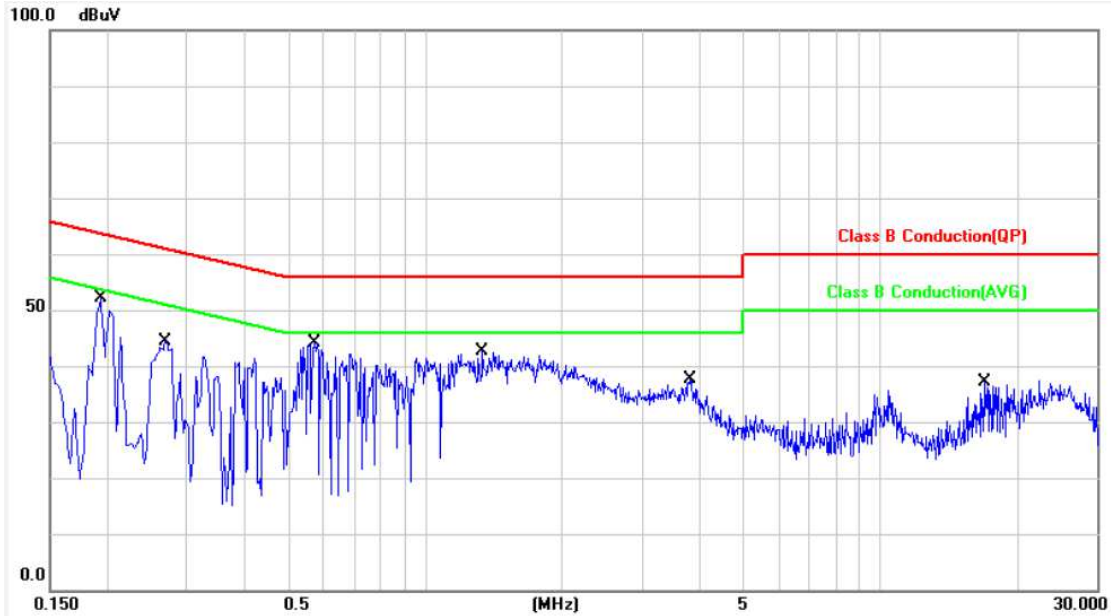

| No. | Frequency (MHz) | Factor (dB) | Reading (dBuV) | Level (dBuV) | Limit (dBuV) | Margin (dB) | Detector | P/F |
|-----|-----------------|-------------|----------------|--------------|--------------|-------------|----------|-----|
| 1   | 0.1940          | 9.88        | 38.88          | 48.76        | 63.86        | -15.10      | QP       | P   |
| 2   | 0.1940          | 9.88        | 27.22          | 37.10        | 53.86        | -16.76      | AVG      | P   |
| 3   | 0.2700          | 9.88        | 34.01          | 43.89        | 61.12        | -17.23      | QP       | P   |
| 4   | 0.2700          | 9.88        | 23.12          | 33.00        | 51.12        | -18.12      | AVG      | P   |
| 5   | 0.5740          | 9.90        | 31.82          | 41.72        | 56.00        | -14.28      | QP       | P   |
| 6   | 0.5740          | 9.90        | 17.28          | 27.18        | 46.00        | -18.82      | AVG      | P   |
| 7   | 1.3420          | 9.95        | 28.32          | 38.27        | 56.00        | -17.73      | QP       | P   |
| 8   | 1.3420          | 9.95        | 18.13          | 28.08        | 46.00        | -17.92      | AVG      | P   |
| 9   | 3.8260          | 10.08       | 21.26          | 31.34        | 56.00        | -24.66      | QP       | P   |
| 10  | 3.8260          | 10.08       | 13.08          | 23.16        | 46.00        | -22.84      | AVG      | P   |
| 11  | 16.9619         | 10.54       | 24.32          | 34.86        | 60.00        | -25.14      | QP       | P   |
| 12  | 16.9619         | 10.54       | 20.50          | 31.04        | 50.00        | -18.96      | AVG      | P   |

Note: Level = Reading + Factor  
Margin = Level – Limit  
Factor = (LISN, ISN, PLC or current probe) Factor + Cable Loss+ Attenuator

Test engineer: Peter



### 3.6. Test Photographs

Front View

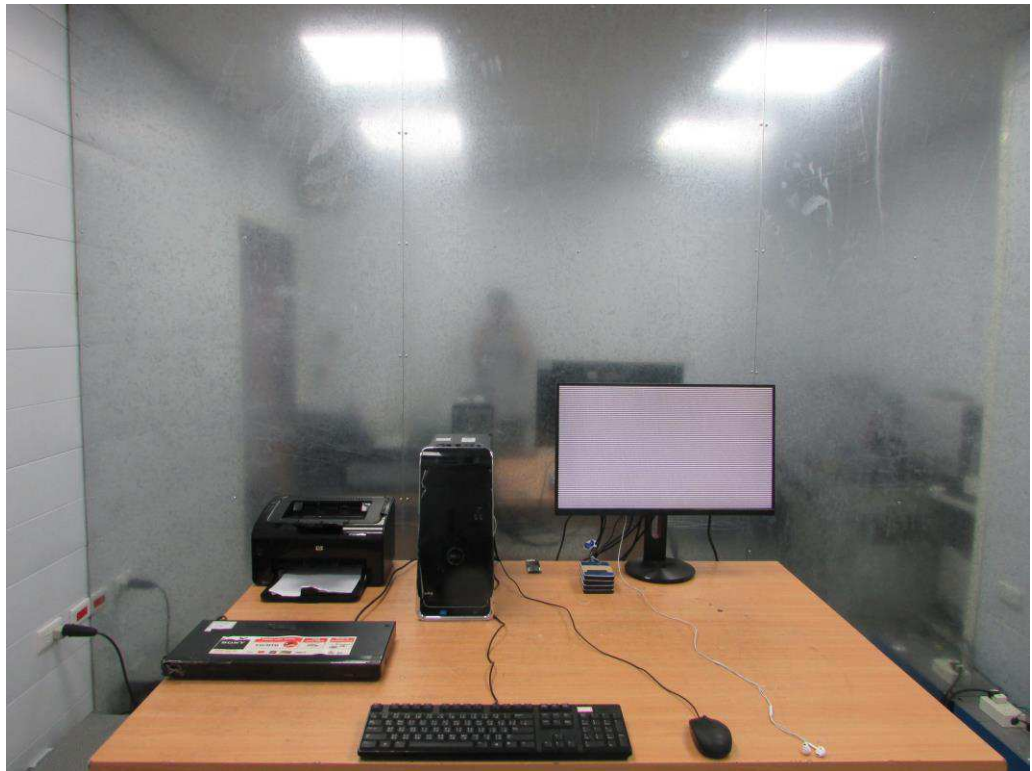

Rear View





## 4. Test of Radiated Emission

### 4.1. Test Limit

Radiated emissions from 30 MHz to 18,000 MHz were measured with a bandwidth of 120 kHz according to the methods defines in ANSI C63.4-2014. The EUT was placed on a nonmetallic stand in the open-field site, 0.8 meter above the ground plane. The interface cables and equipment positions were varied within limits of reasonable applications to determine the positions producing maximum radiated emissions.

For unintentional device, according to § 15.109(a), except for Class A digital devices, the field strength of radiated emissions from unintentional radiators at a distance of 3 meters shall not exceed the following values:

| Frequency (MHz) | Distance Meters | Radiated ( $\mu\text{V} / \text{M}$ ) | Radiated (dB $\mu\text{V} / \text{M}$ ) |
|-----------------|-----------------|---------------------------------------|---|
| 30-88           | 3               | 100                                   | 40.0                                    |
| 88-216          | 3               | 150                                   | 43.5                                    |
| 216-960         | 3               | 200                                   | 46.0                                    |
| Above 960       | 3               | 500                                   | 54.0                                    |

For unintentional device, according to CISPR PUB.22, for Class B digital devices, the general requirement of field strength of radiated emissions from intentional radiators at a distance of 10 meters shall not exceed the below table.

| Frequency (MHz) | Distance Meters | Radiated (dB $\mu\text{V} / \text{M}$ ) |
|-----------------|-----------------|---|
| 30-230          | 10              | 30                                      |
| 230-1000        | 10              | 37                                      |

### 4.2. Test Procedures

- The EUT was placed on a Rota table top 0.8 meter above ground.
- The EUT was set 3/10 meters from the interference receiving antenna which was mounted on the top of a variable height antenna tower.
- The table was rotated 360 degrees to determine the position of the highest radiation.
- The antenna is a half wave dipole and its height is varied between one meter and four meters above ground to find the maximum value of the field strength both horizontal polarization and vertical polarization of the antenna are set to make the measurement.
- For each suspected emission the EUT was arranged to its worst case and then tune the antenna tower (from 1 M to 4 M) and turn table (from 0 degree to 360 degrees) to find the maximum reading.
- Set the test-receiver system to Peak Detect Function and specified bandwidth with Maximum Hold Mode.
- If the emission level of the EUT in peak mode was 6 dB lower than the limit specified, then testing will be stopped and peak values of EUT will be reported, otherwise, the emissions which do not have 6 dB margin will be repeated one by one using the quasi-peak method and reported.

### 4.3. Typical test Setup

#### Below 1GHz Test Setup

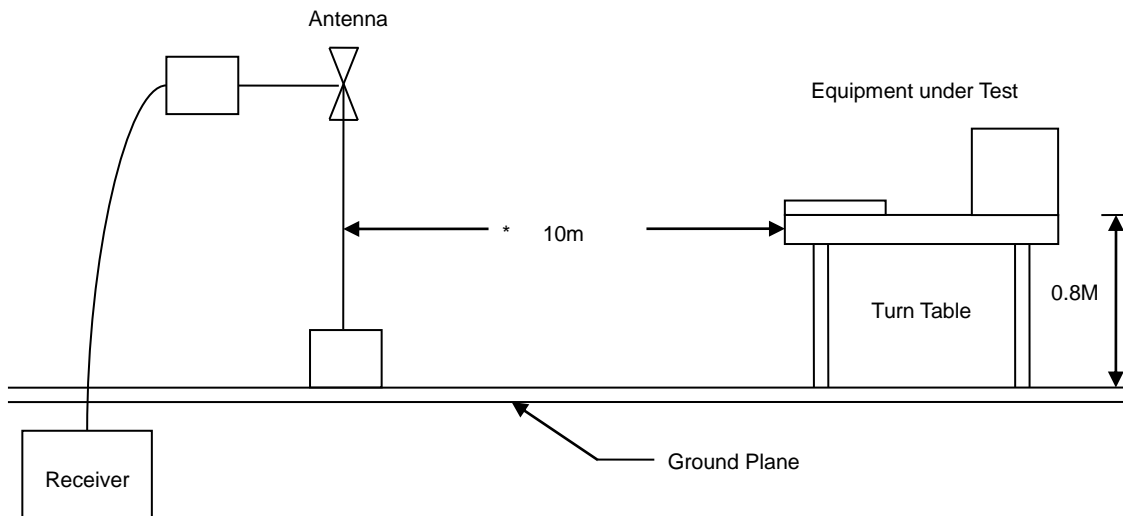

#### Above 1GHz Test Setup

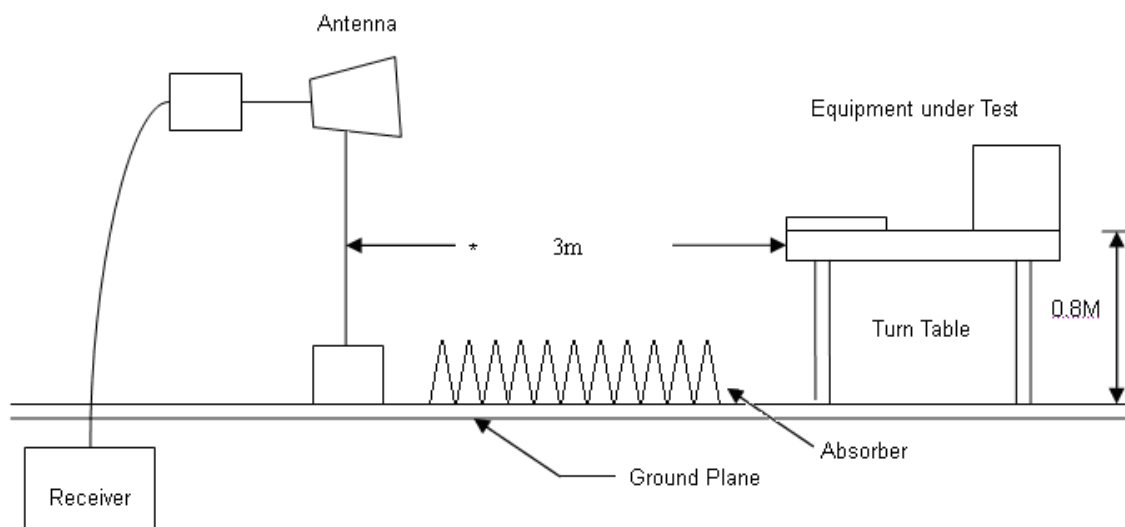

### 4.4. Measurement Equipment

| Instrument        | Manufacturer         | Model No. | Serial No.            | Calibration Date | Valid Date |
|-------------------|----------------------|-----------|-----------------------|------------------|------------|
| Bilog Antenna     | Sunol                | JB1       | A020514-1             | 2017/02/13       | 2018/02/12 |
| Bilog Antenna     | Sunol                | JB1       | A020514-2             | 2017/03/15       | 2018/03/14 |
| EMI Receiver      | R&S                  | ESC13     | 101402                | 2017/02/13       | 2018/02/12 |
| EMI Receiver      | R&S                  | ESC17     | 100963                | 2017/03/06       | 2018/03/05 |
| Preamplifier      | EM Electronics corp. | EM330     | 60610                 | 2017/02/25       | 2018/02/24 |
| Preamplifier      | EM Electronics corp. | EM330     | 60611                 | 2017/02/10       | 2018/02/09 |
| Software          | E3                   | AUDIX     | Version:<br>8.14.806b | N/A              | N/A        |
| Horn Antenna      | EMCO                 | 3115      | 31601                 | 2016/09/05       | 2017/09/04 |
| Spectrum Analyzer | R&S                  | FSP40     | 100047                | 2017/02/13       | 2018/02/12 |
| Preamplifier      | Agilent              | 8449B     | 3008A01954            | 2017/02/09       | 2018/02/08 |



### 4.5. Test Result and Data (30MHz ~ 1GHz)

|           |                 |             |            |
|-----------|-----------------|-------------|------------|
| Power     | : AC 120V       | Pol/Phase   | : VERTICAL |
| Test Mode | : Mode 1        | Temperature | : 20 °C    |
| Test Date | : Aug. 25, 2017 | Humidity    | : 40 %     |
| Model No. | : 270LM00048    |             |            |

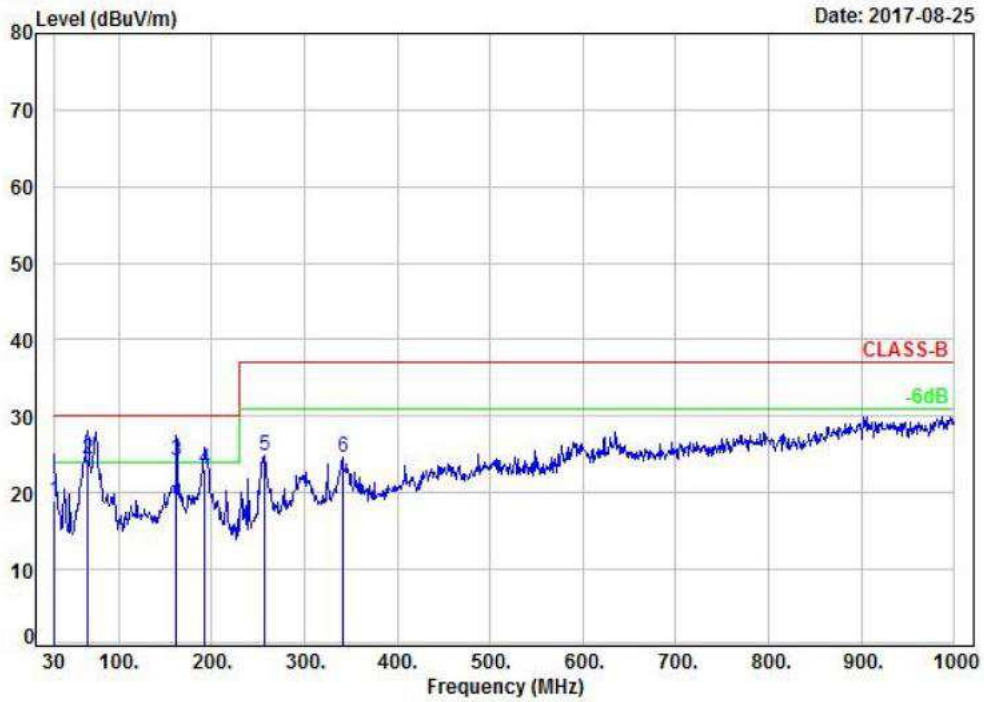

| No. | Frequency (MHz) | Factor (dB/m) | Reading (dBuV) | Level (dBuV/m) | Limit (dBuV/m) | Margin (dB) | Detector | Height (cm) | Azimuth (deg) | P/F |
|-----|-----------------|---------------|----------------|----------------|----------------|-------------|----------|-------------|---------------|-----|
| 1   | 30.93           | -3.45         | 22.47          | 19.02          | 30.00          | -10.98      | QP       | 100         | 8             | P   |
| 2   | 66.53           | -15.79        | 40.22          | 24.43          | 30.00          | -5.57       | QP       | 100         | 149           | P   |
| 3   | 162.04          | -11.06        | 35.18          | 24.12          | 30.00          | -5.88       | QP       | 100         | 241           | P   |
| 4   | 192.05          | -11.32        | 34.41          | 23.09          | 30.00          | -6.91       | QP       | 200         | 207           | P   |
| 5   | 256.98          | -10.55        | 35.32          | 24.77          | 37.00          | -12.23      | Peak     | 100         | 0             | P   |
| 6   | 341.37          | -7.71         | 32.29          | 24.58          | 37.00          | -12.42      | Peak     | 100         | 0             | P   |

Note: Level = Reading + Factor  
 Margin = Level – Limit  
 Factor= Antenna Factor + Cable Loss - Amplifier Factor



|           |                 |             |              |
|-----------|-----------------|-------------|--------------|
| Power     | : AC 120V       | Pol/Phase   | : HORIZONTAL |
| Test Mode | : Mode 1        | Temperature | : 20 °C      |
| Test Date | : Aug. 25, 2017 | Humidity    | : 40 %       |
| Model No. | : 270LM00048    |             |              |

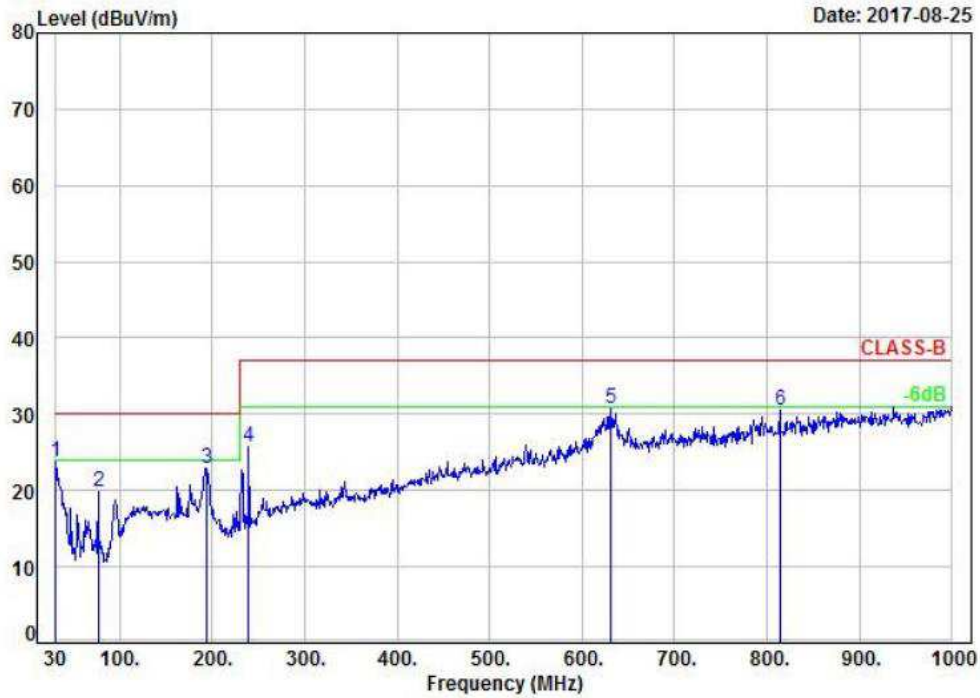

| No. | Frequency (MHz) | Factor (dB/m) | Reading (dBuV) | Level (dBuV/m) | Limit (dBuV/m) | Margin (dB) | Detector | Height (cm) | Azimuth (deg) | P/F |
|-----|-----------------|---------------|----------------|----------------|----------------|-------------|----------|-------------|---------------|-----|
| 1   | 30.00           | -2.78         | 26.58          | 23.80          | 30.00          | -6.20       | Peak     | 100         | 0             | P   |
| 2   | 76.56           | -15.79        | 35.59          | 19.80          | 30.00          | -10.20      | Peak     | 100         | 0             | P   |
| 3   | 193.93          | -10.60        | 33.60          | 23.00          | 30.00          | -7.00       | Peak     | 100         | 0             | P   |
| 4   | 239.52          | -10.61        | 36.37          | 25.76          | 37.00          | -11.24      | Peak     | 100         | 0             | P   |
| 5   | 631.40          | -0.58         | 31.27          | 30.69          | 37.00          | -6.31       | Peak     | 100         | 0             | P   |
| 6   | 813.76          | 2.58          | 27.99          | 30.57          | 37.00          | -6.43       | Peak     | 100         | 0             | P   |

Note: Level = Reading + Factor  
Margin = Level – Limit  
Factor= Antenna Factor + Cable Loss - Amplifier Factor

Test engineer: Peter





4.6. Test Result and Data (1GHz ~ 18GHz)

|           |                 |             |            |
|-----------|-----------------|-------------|------------|
| Power     | : AC 120V       | Pol/Phase   | : VERTICAL |
| Test Mode | : Mode 14       | Temperature | : 20 °C    |
| Test Date | : Aug. 26, 2017 | Humidity    | : 40 %     |
| Model No. | : 270LM00048    |             |            |

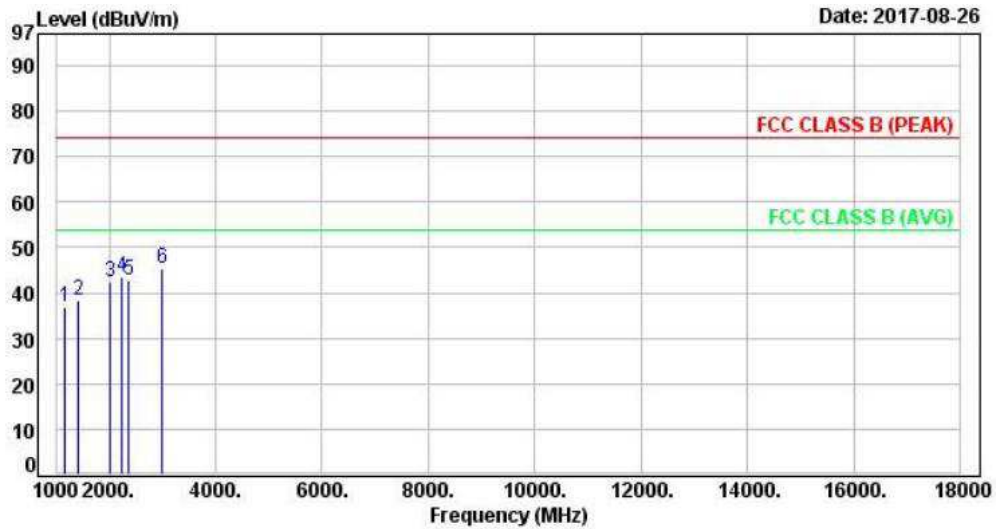

| No. | Frequency (MHz) | Factor (dB/m) | Reading (dBuV) | Level (dBuV/m) | Limit (dBuV/m) | Margin (dB) | Detector | Height (cm) | Azimuth (deg) | P/F |
|-----|-----------------|---------------|----------------|----------------|----------------|-------------|----------|-------------|---------------|-----|
| 1   | 1153.00         | -7.99         | 44.80          | 36.81          | 74.00          | -37.19      | Peak     | 400         | 0             | P   |
| 2   | 1408.00         | -6.35         | 44.84          | 38.49          | 74.00          | -35.51      | Peak     | 400         | 0             | P   |
| 3   | 2020.00         | -2.09         | 44.61          | 42.52          | 74.00          | -31.48      | Peak     | 400         | 0             | P   |
| 4   | 2224.00         | -1.42         | 44.94          | 43.52          | 74.00          | -30.48      | Peak     | 400         | 0             | P   |
| 5   | 2377.00         | -0.94         | 43.86          | 42.92          | 74.00          | -31.08      | Peak     | 400         | 0             | P   |
| 6   | 2989.00         | 1.95          | 43.29          | 45.24          | 74.00          | -28.76      | Peak     | 400         | 0             | P   |

Note: Level = Reading + Factor  
Margin = Level – Limit  
Factor= Antenna Factor + Cable Loss - Amplifier Factor



|           |                 |             |              |
|-----------|-----------------|-------------|--------------|
| Power     | : AC 120V       | Pol/Phase   | : HORIZONTAL |
| Test Mode | : Mode 14       | Temperature | : 20 °C      |
| Test Date | : Aug. 26, 2017 | Humidity    | : 40 %       |
| Model No. | : 270LM00048    |             |              |

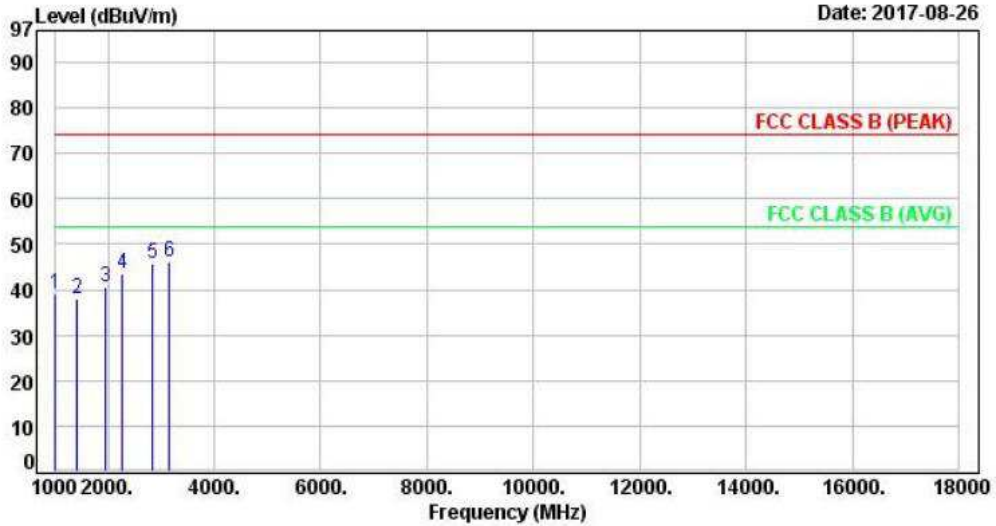

| No. | Frequency (MHz) | Factor (dB/m) | Reading (dBuV) | Level (dBuV/m) | Limit (dBuV/m) | Margin (dB) | Detector | Height (cm) | Azimuth (deg) | P/F |
|-----|-----------------|---------------|----------------|----------------|----------------|-------------|----------|-------------|---------------|-----|
| 1   | 1017.00         | -8.86         | 47.83          | 38.97          | 74.00          | -35.03      | Peak     | 100         | 0             | P   |
| 2   | 1408.00         | -6.35         | 44.22          | 37.87          | 74.00          | -36.13      | Peak     | 100         | 0             | P   |
| 3   | 1952.00         | -2.49         | 43.08          | 40.59          | 74.00          | -33.41      | Peak     | 100         | 0             | P   |
| 4   | 2258.00         | -1.32         | 44.99          | 43.67          | 74.00          | -30.33      | Peak     | 100         | 0             | P   |
| 5   | 2836.00         | 1.18          | 44.45          | 45.63          | 74.00          | -28.37      | Peak     | 100         | 0             | P   |
| 6   | 3142.00         | 2.53          | 43.43          | 45.96          | 74.00          | -28.04      | Peak     | 100         | 0             | P   |

Note: Level = Reading + Factor  
 Margin = Level - Limit  
 Factor= Antenna Factor + Cable Loss - Amplifier Factor

Test engineer: Peter



#### 4.7. Test Photographs (30MHz~1GHz)

Front View



Rear View

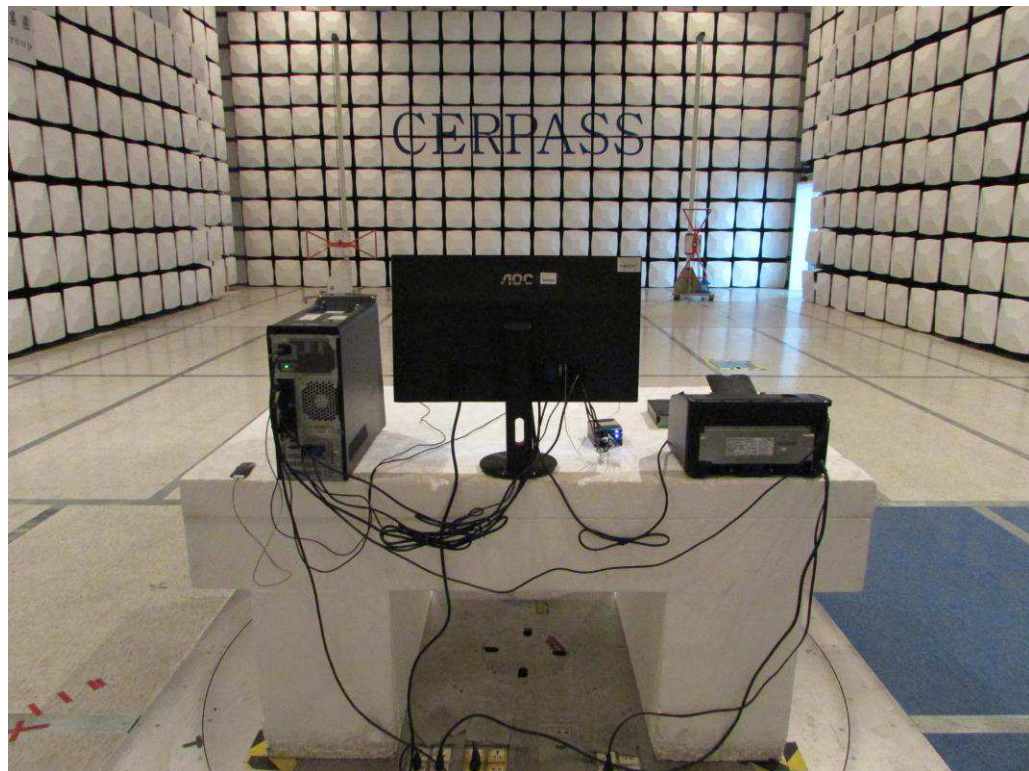



#### 4.8. Test Photographs (1GHz~18GHz)

Front View



Rear View

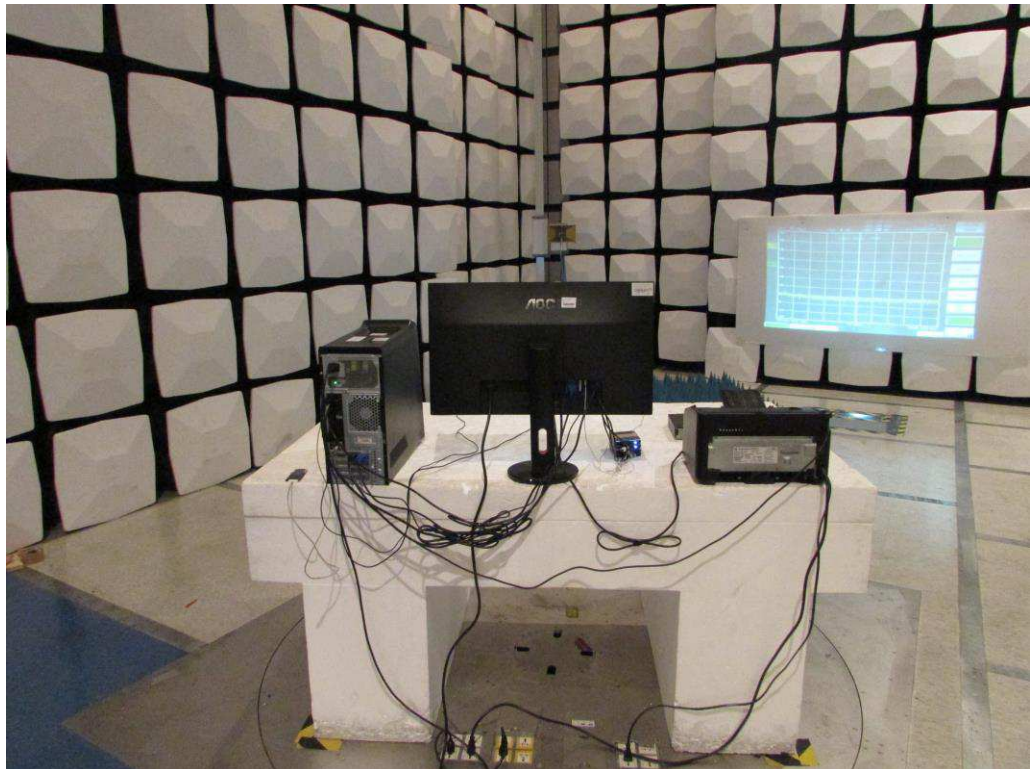



## 5. Photographs of EUT

